



TA500



TA500

Owner's

Manual

IONIC AIR PURIFIER **ionic pro** TURBO

Thank you for purchasing the Ionic Pro® Turbo and congratulations on taking this important step in improving the quality of air in your home, office and other environments. Customer satisfaction is our number one goal. Your Ionic Pro® Turbo is a premium air purifying appliance which comes with a limited one-year warranty.

Enjoy your Ionic Pro® Turbo and visit our website for more exciting quality products and upgrades. The instructional video is located on the Ionic Pro® product page online.

envionproducts.com



TABLE OF CONTENTS

PRODUCT BENEFITS	2
SAFETY INSTRUCTIONS	2
IMPORTANT WARNINGS	4
Main Parts	4
OPERATING THE IONIC PRO® TURBO IONIC AIR PURIFIER	6
Getting Ready	6
Controls/Settings	7
Selecting Settings	7
CLEANING & MAINTENANCE	8
To Clean the Collection Blades	8
To Clean the Main Door	9
To Clean the Internal Ionizing Wires	9
DEEP CLEANING	10
TROUBLE-SHOOTING	11
MORE THINGS YOU SHOULD KNOW	12
Ozone and Your Health	12
ORDERING IONIC PRO® IONIC AIR PURIFIERS	12
ORDERING EXTRA COLLECTION BLADES	12
WARRANTY	13
ARBITRATION AGREEMENT	14

PRODUCT BENEFITS

IONIC PRO® TURBO IONIC AIR PURIFIER PRODUCT BENEFITS

Your Ionic Pro® Turbo ionic air purifier delivers all these wonderful benefits:

- > Oxygen Plus™ technology turns ozone and smog into pure oxygen
- > Patent-pending germicidal chamber kills bacteria and germs on contact
- > Totally silent
- > No filters to replace
- > Easy to use
- > Easy to clean
- > Energy-efficient

Breathe even easier when you order additional Ionic Pro® Air Purifier products today to enjoy fresh and purified air in every room of your home everyday. See our “Ordering Ionic Pro® Air Purifiers” section in this owner’s guide for details.

SAFETY INSTRUCTIONS

EXTREMELY IMPORTANT INFORMATION:

Safety precautions should always be used when operating this or any electrical appliance. Decrease the risk of electrocution, electric shock, injury or fire by reading and following all the warnings below:

Use only as described in this Ionic Pro® Turbo ionic air purifier owner’s manual.

To reduce the risk of electric shock, do not attempt to service the product in any way other than in the manner described in the “**CLEANING & MAINTENANCE**” section of this owner’s manual.

Do not use the Ionic Pro® Turbo ionic air purifier outdoors.

Do not use the Ionic Pro® Turbo ionic air purifier in bathrooms or other humid environments, near fireplaces or in areas where flammable or combustible vapors or products may exist.

The Ionic Pro® Turbo ionic air purifier operates at 120v AC and 60Hz only.

To reduce the risk of electric shock, this product has a grounding-type plug that has a third grounding pin. This plug will fit only into a grounding-type power outlet. If the plug does not fit into the outlet, contact qualified service personnel to install the proper outlet. Do not alter the plug in any way.

Always turn off all controls before unplugging the Ionic Pro® Turbo ionic air purifier from outlet.

Always turn off and unplug this product from outlet before cleaning the collection blades.

Always turn this product off when not in use.

Never touch the internal collection blades, electrodes, ionizing wires, or any part of the Ionic Pro® Turbo ionic air purifier with any object capable of conducting electricity.

SAFETY INSTRUCTIONS

Do not open the door of the Ionic Pro® Turbo air purifier when it is in operation.

Attempting to disassemble the unit may cause serious personal injury to the user and/or result in considerable damage to the unit.

Do not place the Ionic Pro® Turbo ionic air purifier’s cord near a heated surface.

Never operate the Ionic Pro® Turbo ionic air purifier if the plug or cord is damaged or appears damaged. Only qualified service personnel should ever replace or attempt to replace a damaged power cord.

Never use the power cord to pick up, carry, drag, pull, or lift the Ionic Pro® Turbo ionic air purifier. Do not pull the cord against or around sharp corners and edges. This could result in injury to the user or damage to the cord and is prohibited.

Always remove the plug from its power outlet by holding onto the plug itself and pulling gently. Never pull on the cord itself to unplug it from its power outlet.

Use care when operating the Ionic Pro® Turbo ionic air purifier by keeping all fingers, body parts, hair, loose clothing and jewelry away from openings.

Never touch the Ionic Pro® Turbo ionic air purifier or its plug when your hands are wet.

Never try to insert any object into the body of the Ionic Pro® Turbo ionic air purifier when it is in operation.

The Ionic Pro® Turbo ionic air purifier is an electrical appliance. Adult supervision is required when operating the Ionic Pro® Turbo ionic air purifier in the presence of children.

Do not touch the metal blades until after discharging residual electricity by touching blades to an electrical ground such as a water pipe or metal faucet.

The collection blades and ionizing wires should be inspected frequently and cleaned regularly to prevent excessive accumulation that may result in an electrical flashover or a risk of fire.

This product complies with the maximum allowable concentration of ozone of 0.050 parts per million by volume (ppmv) in a 24-hour period. The Health Canada Guideline 2010 recommends that the maximum exposure limit, based on an averaging time of 8 hours, is 0.020 ppmv or less when tested in a sealed, controlled room approximately 30 m³.

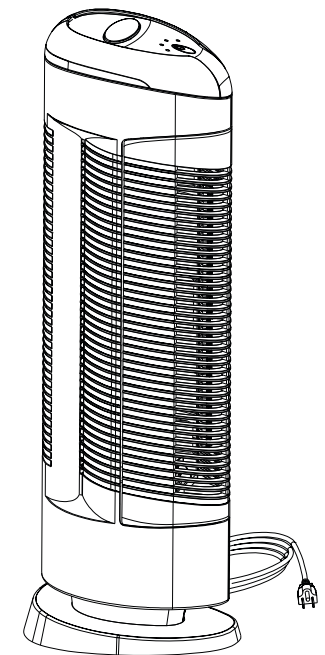

IMPORTANT WARNINGS

IMPORTANT WARNINGS

Before using your Ionic Pro® Turbo air purifier, please read all safety instructions and the following important information.

Collection Blades

Please look at the "Main Parts" diagram and locate the part labeled "A".

These are the collection blades and are a vital part of this amazing ionic air purifying system. The collection blades are where unhealthy pollutants, allergens, irritants and odors are trapped when the Ionic Pro® Turbo Ionic Air Purifier air purifier is in proper working condition and in use.

READ THIS: The metal collection blades may contain a static charge. Do not touch the metal collection blades, even when you take the collection blade unit out for cleaning. (See "CLEANING & MAINTENANCE" section of this manual.)

MAIN PARTS

- A. Collection Blades
- B. Open Button
- C. Control Panel
- D. Outer Housing
- E. Main Door
- F. Power Cord
- G. Base

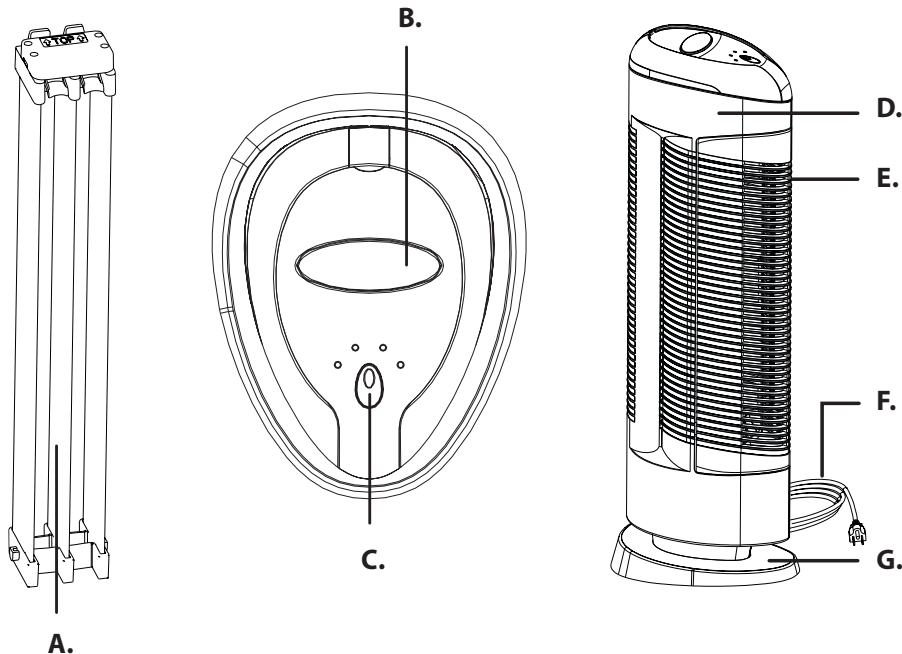

IMPORTANT WARNINGS

Ensuring Quiet Operation

The Ionic Pro® Turbo ionic air purifier is designed to run quietly and requires very little time and effort to maintain in proper working condition. If you hear excessive noise or static coming from your Ionic Pro® Turbo ionic air purifier, it generally indicates that the product needs to be cleaned. Turn off your Ionic Pro® Turbo ionic air purifier, unplug the cord and carefully follow the cleaning instructions in this manual.

To keep your Ionic Pro® Turbo air purifier working properly, it will be necessary to clean the collection blades and ionizing wires after every month of use. (See "CLEANING & MAINTENANCE" section of this owner's manual for the proper techniques.)

WARNING: After cleaning the collection blades with soap and water, allow at least 24 hours for the collection blades to dry thoroughly before re-inserting into the unit. (See "CLEANING AND MAINTENANCE" section.) Water can easily get trapped along the collection blades' many surfaces and edges and damage could result if there is any moisture on the collection blades.

You will need to clean your Ionic Pro® Turbo ionic air purifier more often if it has been exposed to heavy pollution.

Do not place the Ionic Pro® Turbo ionic air purifier near a fireplace. Even if a fireplace is not in use, chimney dust and soot may circulate through the Ionic Pro® Turbo ionic air purifier and then re-circulate and leave a residue on the unit and surrounding areas. We recommend that you do not place your Ionic Pro® Turbo ionic air purifier near candles or oil lamps. If you intend to use candles or oil lamps near your Ionic Pro® Turbo ionic air purifier despite this warning, make sure that the wicks are cut to no more than a quarter inch to cut down on smoke production.



OPERATING THE IONIC PRO® TURBO AIR PURIFIER

Getting Ready

Locate a level surface on which to place Ionic Pro® Turbo ionic air purifier and a grounded 120v outlet. (Follow warnings described in the **"SAFETY INSTRUCTIONS"** section of this manual.) Position your Ionic Pro® Turbo ionic air purifier at least one foot (12 inches) from the wall. Plug in the unit.

You are now ready to turn on your Ionic Pro® Turbo ionic air purifier!

1. **ON/OFF Button**
 - a. **LOW** – output indication light (LOW)
 - b. **MEDIUM** – output indication light (MED)
 - c. **HIGH** – output indication light (HI)
 - d. **CLEAN** – indication light (CLEAN)
2. **CLEAN** – wire cleaning mechanism
3. **OPEN** – main door button
4. **CLEAN** – Indication light

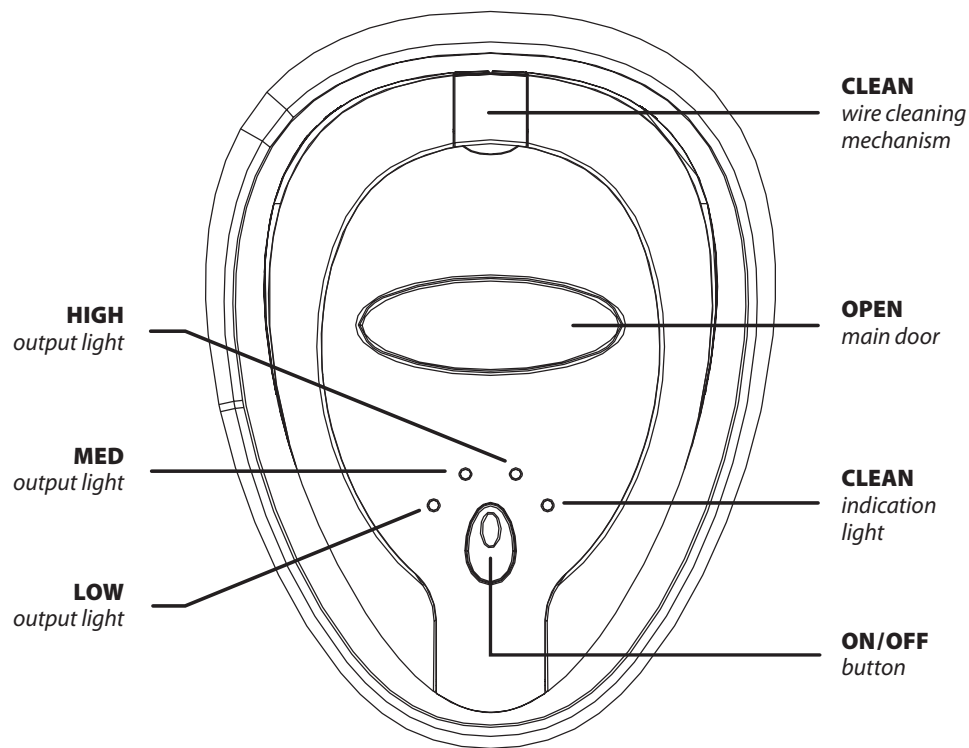

To view the instructional video, visit envionproducts.com. The video is located on the Ionic Pro® Turbo product page.

OPERATING THE IONIC PRO® TURBO AIR PURIFIER

Controls/Settings

1. **ON/OFF BUTTON** Turns unit on and off.
 - A **LOW** –This is the most cost-effective setting. Ideal for medium sized rooms, where windows & doors rarely open.
 - B **MED** –Recommended for medium to large-sized rooms.
 - C **HI** –This maximum output setting is recommended for medium to large rooms and/or areas exposed to heavy dust.
 - D **CLEAN** –This red light goes on when your Ionic Pro® Turbo ionic air purifier needs to be cleaned, or the unit is experiencing some other problem. See **"TROUBLE-SHOOTING"** section.

Selecting Settings

1. Set up the Ionic Pro® Turbo ionic air purifier as described in **"Getting Ready"**.
2. Press the ON/OFF button to activate your ionic air purifier and get ready to enjoy clean, ionized air.
3. The Ionic Pro® Turbo ionic air purifier automatically defaults to the HI (high/maximum output) setting whenever the unit is turned on.
4. Just press the ON/OFF button one more time to select the MED (medium) output setting and press the ON/OFF button once again if you wish to select the LOW output setting.
5. Press the ON/OFF button a fourth time to turn the unit off.
6. The indicator LEDs light up to indicate your current setting (LOW, MED, HI).

Clean Light:

The red CLEAN light will turn on and the unit will shut down if cleaning is overdue or AC input is unstable. The Ionic Pro® Turbo ionic air purifier's collection blades must be cleaned after every month of use and the internal ionizing wires must be cleaned at the same time. (See **"CLEANING & MAINTENANCE"** for full directions.) Once the collection blades are properly cleaned, normal operation should resume.



CLEANING & MAINTENANCE

With very little effort, the Ionic Pro® Turbo ionic air purifier delivers cleaner, fresher, healthier air to your indoor environment. Keep your Ionic Pro® Turbo ionic air purifier functioning properly by cleaning the collection blades after every month of use as recommended. The internal ionizing wires are an important part of the Ionic Pro® Turbo ionic air purifying system and need to be cleaned at the same time or whenever you hear excessive noise. (See "TO CLEAN IONIZING WIRES" and "DEEP CLEANING" sections.)

More frequent cleaning may be required if your Ionic Pro® Turbo ionic air purifier is new or if you place it in a different location. Exposing your Ionic Pro® Turbo ionic air purifier to candle/oil lamp/fireplace soot and smoke is not recommended and will require the collection blades to be cleaned after every exposure. (See "IMPORTANT WARNINGS".)

HELPFUL TIPS: Remember to clean the collection blades and ionizing wires on your Ionic Pro® Turbo air purifier every month and anytime the red CLEAN/FAULT light comes on or whenever you hear your unit begin to make excessive noise.

Do not attempt to remove any other internal parts or disassemble the unit. This may cause serious injury and could damage the unit.

To Clean the Collection Blades:

1. Turn off and unplug your Ionic Pro® Turbo ionic air purifier.
2. Let the unit rest a minute before attempting to remove the collection blades.
3. Pull upward on the release latch of the collection blade unit and pull out from the main door.
4. Remove the collection blade unit.
5. Do not touch the metal blades until after discharging residual electricity by touching blades to an electrical ground such as a water pipe or metal faucet.
6. Wipe away the trapped particles collected on the three blades with a slightly damp sponge or cloth.
7. **IMPORTANT:** To avoid damaging your Ionic Pro® Turbo ionic air purifier, make sure the blades are completely dry and free of all moisture and that your Ionic Pro® Turbo ionic air purifier is turned off before re-insertion. If you used a slightly damp cloth to clean the blades, it is possible the collection blades will be completely dry within two to three hours.

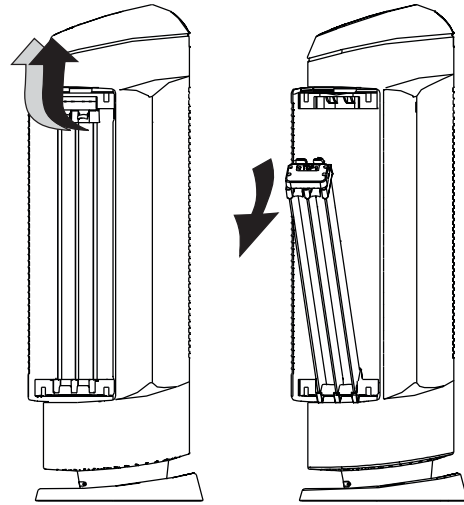

READ THIS: To avoid damage, please make sure that all surfaces and edges of the collection blades are thoroughly dry before re-inserting them into your Ionic Pro® Turbo ionic air purifier.

CLEANING & MAINTENANCE

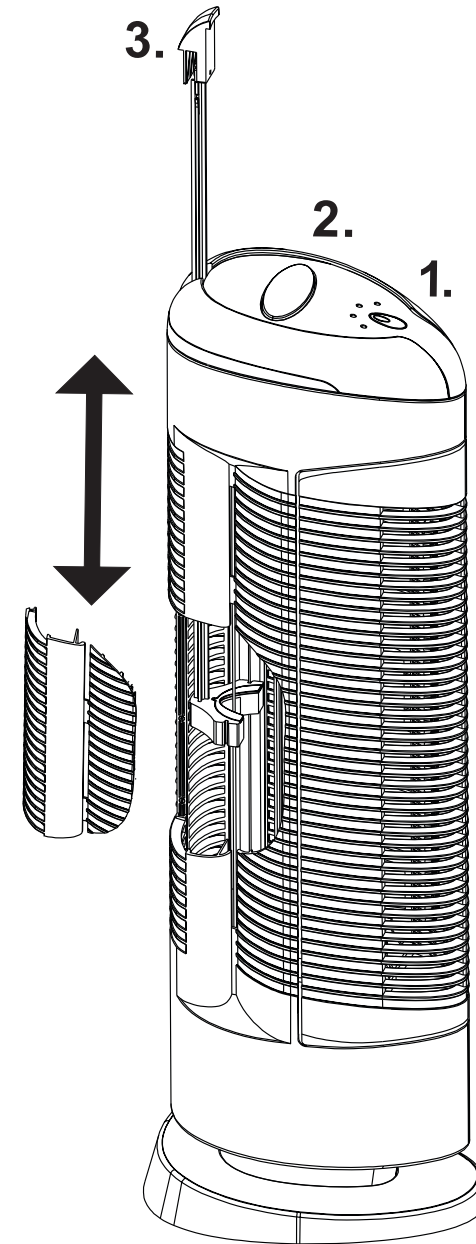

If dust accumulates inside the door of the air purifier, please follow these instructions to clean.

1. Turn off and unplug your Ionic Pro® Turbo air purifier.
2. Open the door and remove the collection blades.
3. Use the soft brush hose attachment to vacuum out the dust. Do not use liquids to clean.

To Clean the Internal Ionizing Wires:

There is an internal wire cleaner that cleans the internal ionizing wires by sliding up and down to scrape off particle residue.

1. Gently pull the lever up and down several times.
2. The internal ionizing wires need to be cleaned after every four weeks of use.

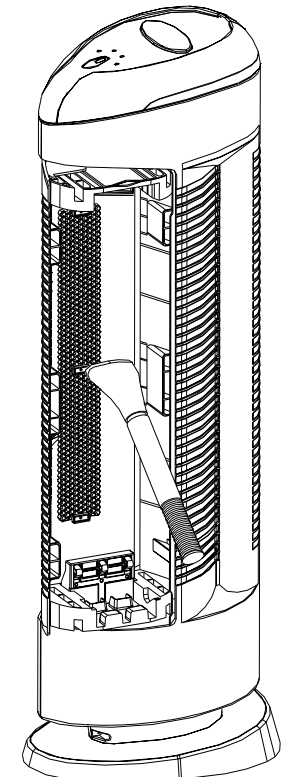

CLEANING & MAINTENANCE

DEEP CLEANING

Noisy functioning (audible loud buzzing sound) is a sign that your Ionic Pro® Turbo ionic air purifier is overdue for a complete clean-up of the collection blades and the internal ionizing wires. The internal ionizing wires must be kept clean to ensure silent and normal operation.

To Deep Clean:

1. Before beginning, make sure you have read all of the safety precautions and cleaning instructions located in the **"SAFETY INSTRUCTION"**, **"IMPORTANT WARNINGS"**, and **"CLEANING & MAINTENANCE"** sections of this owner's manual.
2. First, turn OFF and unplug your Ionic Pro® Turbo ionic air purifier.
3. Let it rest for a minute before sliding out the collection blades as described in the "To Clean the Collection Blades" section of this manual.
4. Use a cloth and warm, sudsy water to wipe away dirt particles on the blades' surfaces and edges.
5. Rinse and let the blades dry thoroughly for 24 hours before re-inserting them into your Ionic Pro® Turbo ionic air purifier. If desired, you can purchase a second set of collection blades to use while the original blades are drying to allow for virtually uninterrupted air purification. (See the **"ORDERING EXTRA COLLECTION BLADES"** section of this owner's manual for details.)
6. Clean the ionizing wires as described in the "To clean the Ionizing Wires" section of this manual.

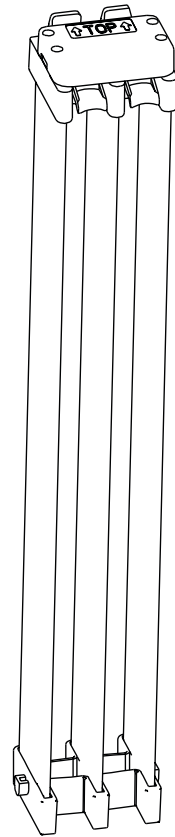

Cleaning External Surfaces

Over time, some particles and dust may accumulate on the external surfaces of your Ionic Pro® Turbo ionic air purifier.

If this happens:

1. Turn off and unplug the unit.
2. Mix one ounce of soap or detergent with five ounces of water and apply sparingly with a moist sponge to wipe the outer case surfaces.
3. Do not allow any water to slip into the internal parts of the Ionic Pro® Turbo ionic air purifier as this could damage its functioning and may result in injury to you.
4. Allow the unit to dry for at least 24 hours before resuming use.

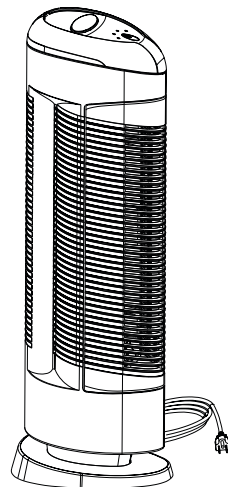

TROUBLE SHOOTING

TROUBLE	REASON	TROUBLE-SHOOTING
Indication/Setting light does not turn on.	Machine is unplugged. ON/OFF button has not been pressed. Main door not closed.	Check if plug is loose. Press the ON/OFF button. Close door.
Red CLEAN light is on or the unit shuts down.	Too much dust has accumulated. AC input unstable or overloaded. Moisture on collection blades.	Turn off, unplug & lift the lever to the wire cleaning mechanism to clean the ionizing wires. Turn off, allow unit to rest a while to return to normal. Temperature & moisture level and then turn on again.
Excessive noise generated.	Collection blades are not installed properly. Too much dust has accumulated. Internal parts are wet.	Remove & replace collection blades & press "On" button. Clean and dry blades and ionizing wires thoroughly.* Keep the machine dry.

*See **"CLEANING & MAINTENANCE"** section.

Ozone and Your Health

After you activate your Ionic Pro® Turbo ionic air purifier, you may notice a new clean scent.

To view the instructional video, visit envionproducts.com. The video is located on the Ionic Pro® Turbo product page.

MORE THINGS YOU SHOULD KNOW

Important Information For Your Health.

The Ionic Pro® Turbo ionic air purifying system utilizes an ionizing process which results in very low ozone emission. The Ionic Pro® Turbo air purifier complies with U.S. safety requirements for low ozone emission (less than 50 parts per billion) and meets the UL867 standard for consumer products. UL867 is the U.L. standard for safety for electrostatic air cleaners.

Individuals with a history of respiratory disease, asthma, heart disease, lung disease, breathing problems or concerns about ozone should ask their doctor whether the concentrations of ozone generated by this or other commercial ionic air purifiers are appropriate for their specific health needs.

ORDERING IONIC PRO® IONIC AIR PURIFIERS

There's no such thing as too much clean air. **Breathe even easier when you order additional Ionic Pro® air purifier products today to enjoy fresh and purified air in every room of your home every day.** Visit our website at envionproducts.com or call **1.800.875.8577** to order your new Ionic Pro® air purifiers today and to find out about our entire line of exciting products.

ORDERING EXTRA COLLECTION BLADES

Enjoy virtually uninterrupted air purification by ordering an extra set of collection blades today. This is a great way to make sure you can always have a clean and thoroughly dry set of collection blades available to insert into your Ionic Pro® Turbo ionic air purifier whenever the other blades are being cleaned and dried for 24 hours. Visit our website at envionproducts.com or call **1.800.875.8577** to order your new collection blades today.



ONE YEAR LIMITED WARRANTY

One Year limited Warranty

Your Ionic Pro® Turbo ionic air purifier is warranted to be free from defects in materials and workmanship for one year from the original purchase date. Should the product have a defect in materials or workmanship, we will repair or replace it without charge to you (a shipping and processing fee will apply). To obtain service under warranty, simply call our customer service center toll-free at **1.800.875.8577**.

This warranty does not cover damage caused by accident, misuse or any use other than as intended and described in this product manual, or damage resulting from failure to maintain and clean this product as specified in this product manual. This warranty applies only to the original purchaser of the Ionic Pro® Turbo ionic air purifier.

ALL EXPRESS AND IMPLIED WARRANTIES FOR THIS PRODUCT, INCLUDING IMPLIED WARRANTIES OF MERCHANTABILITY AND FITNESS FOR A PARTICULAR PURPOSE, ARE LIMITED IN DURATION TO THE WARRANTY PERIOD, AND NO WARRANTIES, WHETHER EXPRESS OR IMPLIED WILL APPLY AFTER THIS PERIOD.

Some states do not allow limitations on the duration of implied warranties, so the above limitation may not apply to you. While this warranty gives you specific legal rights, you may also have other rights which may vary from state to state.

Contact Info for Warranty Service:

Ionic Pro® by BONECO North America Corp.
 P.O. Box 9169 | Van Nuys, CA | 91409-8291
 1.800.875.8577 | envionproducts.com
customerservice@envionproducts.com

Ionic Pro Turbo

©2019 BONECO North America Corp. All Rights Reserved.

US Patent No. 6,855,190, 7,785,404 and D551,328.
 Chinese Patent No. ZL 200420006826.0, ZL200620116403.3 and ZL200630189642.7.
 European Registered Design No. 616867-0001.
 Hong Kong Patent No. HK1063973, HK104898 and 6105471.1.
 Additional patents pending.

ARBITRATION AGREEMENT

PLEASE READ THIS AGREEMENT CAREFULLY. YOU ACCEPT THE TERMS OF THIS AGREEMENT BY RETAINING THE PRODUCT(S) SHIPPED IN CONNECTION WITH THIS AGREEMENT (THE "PRODUCTS") FOR MORE THAN THIRTY (30) DAYS AFTER RECEIPT. IF YOU DO NOT AGREE TO THE TERMS OF THIS AGREEMENT, YOU MAY RETURN THE PRODUCT TO COMPANY WITHIN THIRTY (30) DAYS OF RECEIPT FOR A FULL REFUND.

THIS ARBITRATION AGREEMENT ("AGREEMENT") AFFECTS YOUR LEGAL RIGHTS AND REMEDIES BY PROVIDING THAT DISPUTES BETWEEN YOU AND THE MANUFACTURER, DISTRIBUTOR AND/OR SELLER OF THIS PRODUCT (COLLECTIVELY, "COMPANY"), MUST BE RESOLVED THROUGH BINDING ARBITRATION AND NOT IN COURT. IT ALSO PROVIDES THAT ANY DISPUTE CANNOT BE RESOLVED IN A CLASS ACTION OR OTHER PROCEEDING WHERE YOU REPRESENT OTHER PERSONS OR OTHER PERSONS REPRESENT YOU, AND THAT NO CLASS OR REPRESENTATIVE ARBITRATIONS ARE PERMITTED. PLEASE CAREFULLY READ ALL TERMS IN THIS AGREEMENT.

1. RESOLUTION OF CLAIMS OR DISPUTES.

Any claim or dispute between you and Company (or any of Company's subsidiaries or affiliates) arising out of or relating in any way to the Product or this Agreement shall be resolved through final, binding arbitration. This arbitration obligation is reciprocally binding on both you and the Company and applies regardless of whether the claim or dispute involves a tort, fraud, misrepresentation, product liability, negligence, violation of a statute, or any other legal theory. Both you and Company specifically acknowledge and agree that you waive your right to bring a lawsuit based on such claims or disputes and to have such lawsuit resolved by a judge or jury.

2. LIMITATION OF LEGAL REMEDIES.

All arbitrations under this Agreement shall be conducted on an individual (and not a class-wide) basis, and an arbitrator shall have no authority to award class-wide relief. You acknowledge and agree that this Agreement specifically prohibits you and the Company from commencing arbitration proceedings as a representative of others or joining in any arbitration proceedings brought by any other person. The parties agree that no class or representative actions of any type are permitted.

3. ARBITRATION PROCEDURES.

- a. Before instituting an arbitration, if you have any dispute, we strongly encourage you to contact the Company to try to resolve the matter by calling 800.875.8577, although you are not required to do so.
- b. The arbitration of any claim or dispute under this Agreement shall be conducted in accordance with the expedited procedures set forth in the JAMS Comprehensive Arbitration Rules and Procedures as those Rules exist on the date you receive the Product, including Rules 16.1 and 16.2 of those Rules. These rules and procedures are available by calling JAMS or by visiting its web site at www.jamsadr.com. The arbitration of any claim or dispute under this Agreement shall be conducted by an arbitrator who has at least five years of experience conducting arbitrations.
- c. The arbitration of any claim or dispute under this Agreement shall be conducted in the State of California or the location in which you received this Agreement. For claims of \$10,000 or less, you may choose whether the arbitration proceeds in person, by telephone, or based only on submissions.
- d. The Company shall pay costs for the arbitration of claims, including any JAMS Case Management Fee and all professional fees for the arbitrator's services. The Company shall pay the fees and costs of its own counsel, experts and witnesses and shall not be able to recoup them from you even if you do not prevail in the arbitration. Unless otherwise provided by law, you acknowledge and agree that you shall pay the fees and costs of your own counsel, experts and witnesses.

4. CHOICE OF LAW.

The arbitration provisions of this Agreement and any arbitration conducted pursuant to the terms of this Agreement shall be governed by the Federal Arbitration Act (9 U.S.C. Secs. 1-16). In this respect, the parties acknowledge that this Agreement involves a transaction conducted in interstate commerce. Otherwise, this Agreement and the rights of the parties hereunder shall be governed by and construed in accordance with the laws of the State of California, exclusive of conflict or choice of law rules.

5. SEVERABILITY.

If any provision of this Agreement is declared or found to be unlawful, unenforceable or void, such provision will be ineffective only to the extent that it is found unlawful, unenforceable or void, and the remainder of the provision and all other provisions shall remain fully enforceable.

IONIC AIR PURIFIER
ionic pro
TURBO



