



Air Ratchet

Model: 07637



**Actual product may vary slightly*

Please carefully read and save these instructions before attempting to assemble, maintain, install, or operate this product. Observe all safety information to protect yourself and others. Failure to observe the instructions may result in property damage and/or personal injury. Please keep instructions for future reference.

For warranty purchases, please keep your dated proof of purchase. File or attach to the manual for safekeeping.



Important Operating Instructions

CALIFORNIA PROPOSITION 65

WARNING: You can create dust when you cut, sand, drill or grind materials such as wood, paint, metal, concrete, cement, or other masonry. This dust often contains chemicals known to cause cancer, birth defects, or other reproductive harm. Wear protective gear.

WARNING: This product or its power cord may contain chemicals, including lead, known to the State of California to cause cancer and birth defects or other reproductive harm. Wash hands after handling.

Important!

When using equipment, a few safety precautions must be observed to avoid injuries and damage. Please read the complete operating manual with due care. Keep this manual in a safe place, so that the information is available at all times. If you give the equipment to any other person, give them these operating instructions as well. We accept no liability for damage or accidents which arise due to non-observance of these instructions and the safety information herein.

SPECIFICATIONS

Drive:	3/8"
Required Pressure:	90 PSI
Average Air Consumption:	4 CFM
Maximum Torque:	60 ft.-lbs.
Free Speed:	160 RPM
Air Inlet:	1/4"

Any failures made in following the safety regulations and instructions may result in an electric shock, fire, and/or serious injury.



Important Operating Instructions

GENERAL SAFETY INSTRUCTIONS

- Keep the work area clean and well lit. Cluttered and dark areas increase the risk of electric shock, fire, and injury to persons.
- Do not operate the tool in explosive atmospheres, such as in the presence of flammable liquids, gases, or dust. The tool is able to create sparks resulting in the ignition of the dust or fumes.
- Keep bystanders, children, and visitors away while operating the tool. Distractions may result in the loss of control of the tool.
- Stay alert. Watch what you are doing and use common sense when operating the tool. Do not use the tool while tired or under the influence of drugs, medications, or alcohol.
- Dress properly. Do not wear loose clothing or jewelry. Contain long hair. Keep hair, clothing, and gloves away from moving parts. Loose clothes, jewelry, or long hair increases the risk of injury to persons as a result of being caught in moving parts.
- Avoid unintentional starting. Be sure the switch is off before connecting to the air supply. Do not carry the tool with your finger on the switch or connect the tool to the air supply with the switch on.
- Remove adjusting keys and wrenches before turning the tool on. A wrench or key that is left attached to a rotating part of the tool increases the risk of personal injury.
- Do not overreach. Keep proper footing and balance at all times. Proper footing and balance enables better control of the tool in unexpected situations.
- Use safety equipment. A dust mask, non-skid safety shoes and a hard hat must be used for the applicable conditions.
- Always wear eye protection. Wear ANSI-approved safety goggles.
- Always wear hearing protection when using the tool. Prolonged exposure to high intensity noise may result in hearing loss.



Important Operating Instructions

GENERAL SAFETY INSTRUCTIONS

- Risk of electric shock. This tool is not provided with an insulated gripping surface. Contact with a “live” wire will also make exposed metal parts of the tool “live” and shock the operator.
- Avoid body contact with grounded surfaces such as pipes, radiators, ranges, and refrigerators. There is an increased risk of electric shock.
- Examine the work piece to avoid contact with hidden wiring. Thoroughly investigate the work piece for possible hidden wiring before performing work. Contact with live wiring will shock the operator.
- Use clamps or another practical way to secure and support the work piece to a stable platform. Holding the work by hand or against the body is unstable and may lead to loss of control.
- Do not force the tool. Use the correct tool for the job. The correct tool will do the job better and safer at the rate for which the tool is designed.
- Do not use the tool if the switch does not operate. Any tool that cannot be controlled with the switch is dangerous and must be repaired.
- Disconnect the tool from the air source before making any adjustments, changing accessories, or storing the tool. Such preventive safety measures reduce the risk of starting the tool unintentionally. Turn off and detach the air supply, safely discharge any residual air pressure, and release the trigger before leaving the work area.
- Store the tool out of the reach of children and other untrained persons. This tool is dangerous in the hands of untrained users.
- Maintain the tool with care. Keep a cutting tool sharp and clean. A properly maintained tool, with sharp cutting edges reduces the risk of binding and is easier to control.
- Check for misalignment or binding of moving parts, and any other condition that affects the tool’s operation. If damaged, have the tool serviced before using. Many accidents are caused by poorly maintained tools. There is a risk of bursting if the tool is damaged.
- Use only accessories that are identified by the manufacturer for the specific tool’s model. Use of an accessory not intended for use with the specific tool model, increases the risk of injury to persons.



Important Operating Instructions

GENERAL SAFETY INSTRUCTIONS

- Tool service must be performed only by qualified repair personnel.
- When servicing a tool, use only identical replacement parts. Use only authorized parts.
- Use only the lubricants supplied with the tool or specified by the manufacturer.
- Never connect to an air source that is capable of exceeding 200 PSI. Over pressurizing the tool may cause bursting, abnormal operation, breakage of the tool, or serious injury. Use only clean, dry, regulated compressed air at the rated pressure or within the rated pressure range as marked on the tool. Always verify prior to using the tool that the air source has been adjusted to the rated air pressure or within the rated air-pressure range.
- Never use oxygen, carbon dioxide, combustible gases, or any bottled gas as an air source for the tool. Such gases are capable of explosion and serious injury.

SPECIFIC SAFETY INSTRUCTIONS

- The warnings and precautions discussed in this manual cannot cover all possible conditions and situations that may occur. It must be understood by the operator that common sense and caution are factors which cannot be built into this product, but must be supplied by the operator.
- Only use accessories rated to handle the forces exerted by this tool during operation. Other accessories not designed for the forces generated may break and forcefully launch pieces.
- Attach all accessories properly to the tool before connecting the air supply. A loose accessory may detach or break during operation.
- Obey the manual for the air compressor used to power this tool.
- Install an in-line shutoff valve to allow immediate control over the air supply in an emergency, even if a hose is ruptured.
- Use this tool with both hands only. Using tools with only one hand can result in loss of control.
- Do not lay the tool down until it has come to a complete stop. Moving parts can grab the surface and pull the tool out of your control.



Important Operating Instructions

VIBRATION PRECAUTIONS

This tool vibrates during use. Repeated or long-term exposure to vibration may cause temporary or permanent physical injury, particularly to the hands, arms, and shoulders. To reduce the risk of vibration-related injury:

1. Anyone using vibrating tools regularly or for an extended period of time should first be examined by a doctor and then have regular medical check-ups to ensure medical problems are not being caused or worsened from use. Pregnant women or people who have impaired blood circulation to the hand, past hand injuries, nervous system disorders, diabetes, or Raynaud's Disease should not use this tool. If you feel any symptoms related to vibration (such as tingling, numbness, and white or blue fingers), seek medical advice as soon as possible.
2. Do not smoke during use. Nicotine reduces the blood supply to the hands and fingers, increasing the risk of vibration-related injury.
3. Wear suitable gloves to reduce the vibration effects on the user.
4. Use tools with lower vibration when there is a choice.
5. Include vibration-free periods each day of work.
6. Grip the tool as lightly as possible (while still maintaining a secure hold). Let the tool do the work.
7. To reduce vibration, maintain tool as explained in this manual. If abnormal vibration occurs, stop immediately.

INITIAL SETUP & ASSEMBLY

Air Supply

WARNING: To prevent serious injury from explosion, use only clean, dry, regulated, compressed air to power this tool. Do not use oxygen, carbon dioxide, combustible gases, or any other bottled gas as a power source for this tool.

1. Incorporate a filter, regulator with pressure gauge, oiler, in-line shutoff valve, and quick coupler for best service. Refer to the diagram at the end of this manual for more information. **An in-line shut-off ball valve is an important safety device because it**



Important Operating Instructions

controls the air supply even if the air hose is ruptured. The shut-off valve should be a ball valve because it can be closed quickly.

Note: if an automatic oiler system is not used, add a few drops of pneumatic tool oil to the airline connection before operation. Add a few more drops after each hour of continual use.

2. Attach an air hose to the compressor's air outlet. Connect the air hose to the air inlet of the tool. Other components, such as a coupler plug and quick coupler, will make operation more efficient, but are not required.

WARNING: To prevent serious injury from accidental operation, do not install a female quick coupler on the tool. Such a coupler contains an air valve that will allow the air tool to retain pressure and operate accidentally after the air supply is disconnected.

Note: Air flow, and therefore tool performance, can be hindered by undersized air supply components. The air hose must be long enough to reach the work area with enough extra length to allow free movement while working.

3. Release the tool's trigger.

4. Close the in-line shut-off valve between the compressor and the tool.

5. Turn on the air compressor according to the manufacturer's directions and allow it to build up pressure until it cycles off.

6. Adjust the air compressor's output regulator so that the air output is enough to properly power the tool, but the output will not exceed the tool's maximum air pressure at any time. Adjust the pressure gradually, while checking the air output gauge to set the right pressure range.

7. Inspect the air connections for leaks. Repair any leaks found.

8. If the tool will not be used at this time, turn off and detach the air supply, safely discharge any residual air pressure, and release the trigger to prevent accidental operation.

Note: Residual air pressure should not be present after the tool is disconnected from the air supply. However, it is a good safety measure to attempt to discharge the tool in a safe fashion after disconnecting to ensure that the tool is disconnected and not powered.



Important Operating Instructions

WARNING: Read the ENTIRE important operating instructions before set-up or use of this product.

Inspect tool before use, looking for damaged, loose, and missing parts. If any problems are found, do not use the tool until it has been repaired.

TOOL SET-UP

WARNING: To prevent serious injury from accidental operation, turn off the tool, detach the air supply, safely discharge any residual air pressure in the tool, and release the trigger before performing any inspection, maintenance, or cleaning procedures.

To prevent serious injury, do not adjust or tamper with any control or component in a way not specifically explained within this manual. Improper adjustment can result in tool failure or other serious hazards.

Installing & removing the sockets

1. To install the sockets:

- a. Disconnect the tool from the air source
- b. Select the suitable and desirable socket size. (not included)
- c. Press fit the anvil into the socket.

2. To remove the socket

- a. Disconnect the tool from the air source.
- b. Use your hand or a suitable tool to carefully remove the socket.

WORK AREA SET-UP

1. Designate a work area that is clean and well-lit. The work area must not allow access by children or pets to prevent distraction and injury.

2. Route the air hose along a safe route to reach the work area without creating a trip hazard or exposing the air hose to possible damage. The air hose must be long enough to reach the work area with enough extra length to allow free movement while working.

3. Secure a loose work piece using a vise or clamps (not included) to prevent movement while working.



Important Operating Instructions

4. There must not be hazardous objects (such as utility lines or foreign objects) nearby that will present a hazard while working.

OPERATING INSTRUCTIONS

NOTE: For additional information regarding the parts listed in the following pages, refer to the DIAGRAM and PARTS LIST at the end of this manual.

Before Use

To maintain maximum performance of the air tool, it must be lubricated each time it is used. Dust, dirt, rust, and oil residue will build up inside the tool and reduce the performance. The tool should be lubricated manually through the air inlet fitting.

Tightening: Set the Forward/Reverse Button to “F”

1. Tighten the nut as tight as you can by hand.
2. Place the socket (not included) over the nut you wish to tighten.
3. Grip the ratchet wrench firmly and gently squeeze the throttle lever.

Note: If the ratchet wrench cannot tighten it to your satisfaction, do not raise the air pressure on the compressor over 90 PSI. Pressure above 90 PSI will strip the work piece and damage the tool. Use appropriate methods and tools to tighten the nut.

4. If available, check the recommended torque specifications for the nut. Use a torque wrench to tighten the nut to the proper setting after using the ratchet wrench.

Loosening: Set Forward/Reverse Button to “R”

1. Place the socket (not included) over the nut you wish to loosen.
2. Grip the ratchet wrench firmly and gently squeeze the throttle lever.

Note: If the ratchet wrench cannot loosen the nut to your satisfaction, do not raise the air pressure on the compressor over 90 PSI. Pressure above 90 PSI will strip the work piece and damage the tool. Use appropriate methods and tools to loosen the nut.

3. When the nut is loosened, release the throttle lever. Turn off the air compressor and disconnect the hose.
4. If needed, remove the nut from the socket.



Important Operating Instructions

STORAGE & MAINTENANCE

WARNING: Procedures not specifically explained in this manual must be performed only by a qualified technician.

To prevent serious injury from accidental operation, turn off the tool, detach the air supply, safely discharge any residual air pressure in the tool, and release the trigger before performing any inspection, maintenance, or cleaning procedures.

To prevent serious injury from tool failure, do not use damaged equipment. If abnormal noise, vibration, or leaking occurs, have the problem corrected before use.

To prevent serious injury from explosion, lubricate the tool only with specified lubricants. Lubricate the air inlet using only pneumatic tool oil. Other lubricants may damage the mechanism and may be highly flammable, causing an explosion.

Note: These procedures are in addition to the regular checks and maintenance explained as part of the regular operation of the air-operated tool.

1. Before each use:

Inspect the general condition of the tool. Check for:

- Loose hardware or housing
- Misalignment or binding of moving parts
- Cracked or broken parts
- Any other condition that may affect its safe operation

Apply a few drops of oil to the throttle lever, pin, and actuation pin.

2. Daily:

With a clean cloth, remove all dirt, oil, and grease from the Ratchet. If necessary, you may use a mild detergent. Do not use solvents, as damage to the Ratchet may occur. Do not immerse the Ratchet in any liquids.

Air Supply Set-up

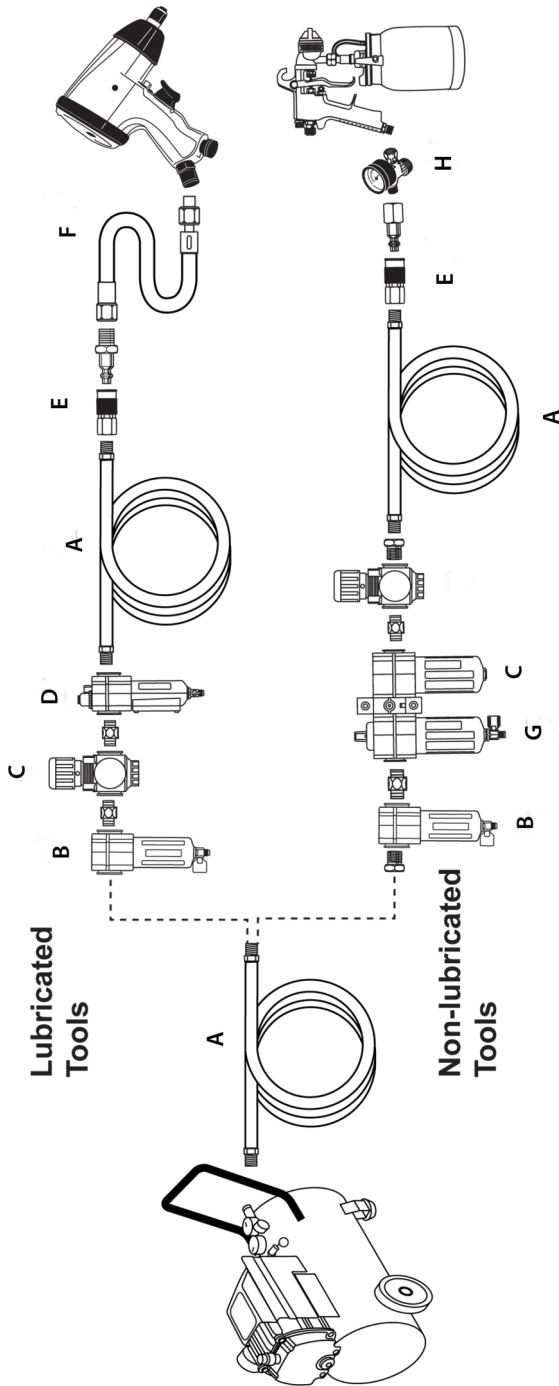

#	Description	Function
A	Air Hose	Connects air source to tool
B	Filter	Prevents dirt and condensation from damaging tool or work piece
C	Regulator	Adjusts air pressure on tool
D	Lubricator (Optional)	Air tool lubrication
E	Coupler and Plug	Provides quick connection and release
F	Leader Hose (Optional)	Increases coupler life
G	Air Cleaner/Dryer (Optional)	Prevents water vapor from damaging work piece
H	Air Adjusting Valve (Optional)	Fine tuning airflow at tool



Important Operating Instructions

TROUBLESHOOTING GUIDE

Symptom	Possible Cause(s)	Corrective Action
The tool runs slowly or will not operate	There is grit or gum in the tool	Flush the tool with air tool oil or gum solvent
	The tool is out of oil	Lubricate the tool according to instructions
	The air pressure is low	Adjust the regulator on the tool to the maximum setting
		Adjust the compressor regulator to the tool's maximum setting of 90 PSI
	The air hose leaks	Tighten and seal the hose fittings with pipe thread tape if leaks are found
	The air pressure drops	Ensure the hose is the proper size
		Do not use multiple hoses connected with a quick connect fitting. This will reduce the power of the tool
	There is a worn rotor blade in the motor	Replace the rotor blade
There is a worn ball bearing in the motor	Remove and inspect the bearing for rust, dirt, and grit. Replace or clean and grease the bearing with bearing grease	
There is moisture blowing out of the tool's exhaust	There is water in the tank	Drain the tank. Lubricate the tool and run it until there is no water evident. Lubricate the tool again and run for 1-2 seconds
<p>WARNING: Follow all safety precautions whenever diagnosing or servicing the tool. Disconnect the air supply before servicing</p>		



Important Operating Instructions

WARRANTY

Limited Manufacturer Warranty

North American Tool Industries (NATI) makes every effort to ensure that this product meets high quality and durability standards. NATI warrants to the original retail consumer a 1-year limited warranty from the date the product was purchased at retail and each product is free from defects in materials. Warranty does not apply to defects due directly or indirectly to misuse, abuse, negligence or accidents, repairs or alterations, or a lack of maintenance. This product is intended for personal use. The warranty will be voided if used in commercial, rental, or industrial applications. NATI shall in no event be liable for death, injuries to persons or property, or for incidental, special or consequential damages arising from the use of our products. To receive service under warranty, the original manufacturer part must be returned for examination by an authorized service center. Shipping and handling charges may apply. If a defect is found, NATI will either repair or replace the product at its discretion.

DO NOT RETURN TO STORE

For Customer Service:

Email feedback@natitools.com or

Call **1-800-348-5004**



PARTS LIST

Air Ratchet

Model: 07637

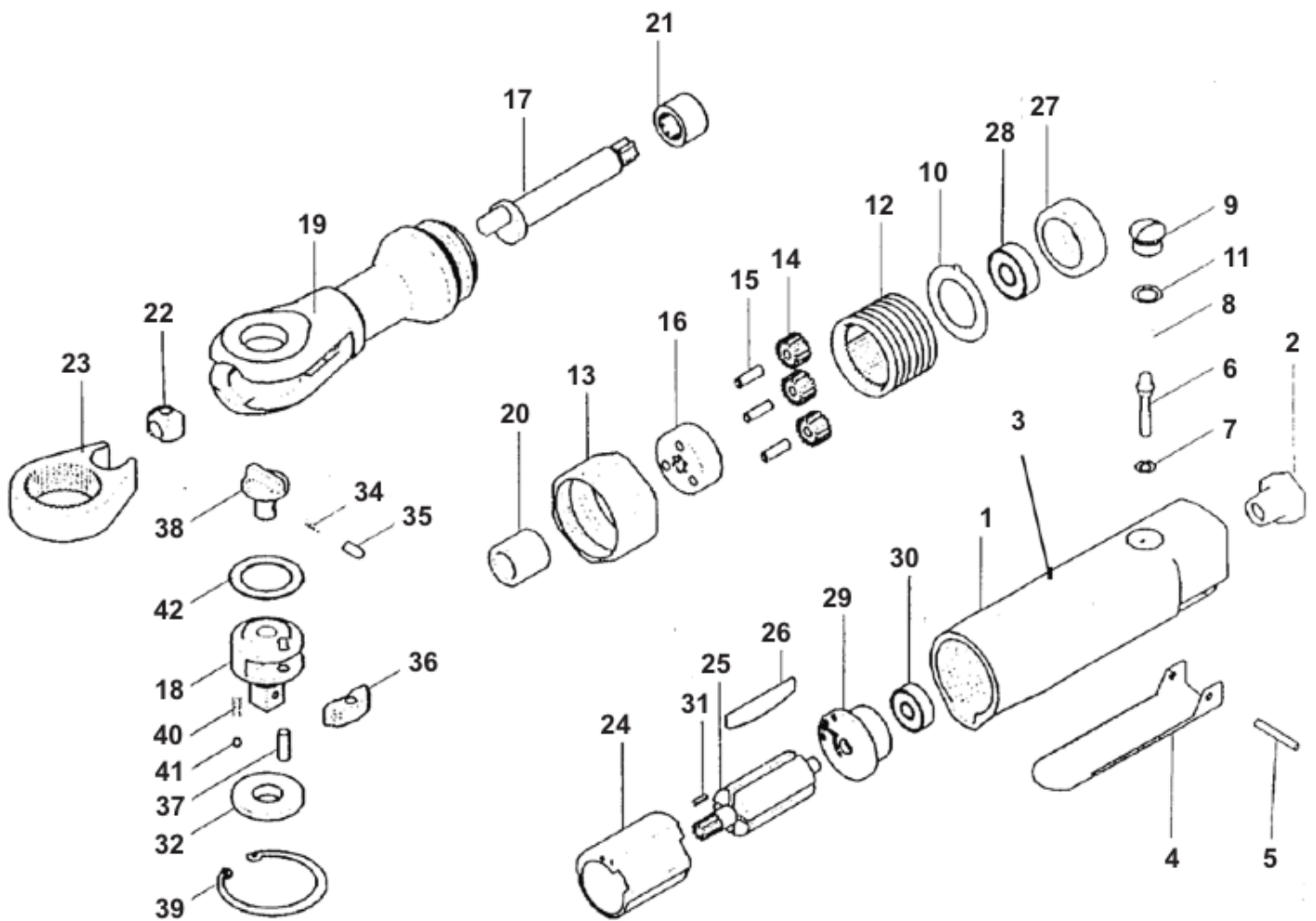



PARTS LIST

Model: 07637

Air Ratchet

#	Description	QTY.
1	Housing	1
2	Air Inlet	1
3	Actuation Pin	1
4	Throttle Lever	1
5	Pin	1
6	Valve Stem	1
7	O-Ring	1
8	Spring	1
9	Valve Plug	1
10	Washer	1
11	O-Ring	1
12	Thread Ring Gear	1
13	Cap	1
14	Gear	3
15	Pin	3
16	Gear Plate	1
17	Crankshaft	1
18	Anvil	1
19	Ratchet Housing	1
20	Bushing	1
21	Needle Bearing	1

#	Description	QTY.
22	Drive Bushing	1
23	Ratchet Yoke	1
24	Cylinder	1
25	Rotor	1
26	Rotor Blade	4
27	Front Plate	1
28	Bearing	1
29	End Plate	1
30	Bearing	1
31	Pin	1
32	Washer	1
34	Spring	1
35	Lock Pin	1
36	Ratchet Pawl	1
37	Pin	1
38	Forward/Reverse Button	1
39	Retainer Ring	1
40	Spring	2
41	Steel Ball	2
42	Washer	1
43	1/4" Coupler (not shown)	1