

## CEILING LIGHT

## SPEC SHEET

Catalog No. : SOL12-3K-BZ

Type : Ceiling / Canopy / Wall

Project Name :

Location :

Qty :

Date :



Suitable for  
**Wet Locations**

PROBRITE's Architectural Outdoor/Indoor LED Security Flush Ceiling and Wall Mount benefits from the latest in LED technology to save 85% on energy bills, lasts over 50,000-hour and doesn't require any bulb changes. Its hands-free installation feature makes the fixture easy to mount and comes fully gasketed and water-tight for outdoor and indoor installation. The modern look is designed for both ceiling and wall mounting applications where extra style is desired.

### APPLICATIONS

Versatile fixture for any ceiling, canopy or wall mount. Used for both outdoor and indoor applications.



### PRODUCT PERFORMANCE AT A GLANCE

SYSTEM WATTAGE	LED WATTAGE	LUMENS	LPW	CRI	REPLACES
12W	11W	900 lm	75 lm/w	≥80	75W Incandescent

### HOUSING

Die cast aluminum back plate housing with UV-stabilized vandal-resistant polycarbonate lens and front-trim.

### IP RATING & LISTINGS

LED light fixture is outdoor weather-proof rated IP65.

cULus, FCC Certified

### OPTICS

Wide-angle Type V circular distribution with glare-free frosted lens eliminates LED "hot-spots" and minimizes eye-glare.

### MOUNTING

#### Ceiling / Wall Mount:

Flush mount to ceiling, canopy or wall.

Unit has a detachable mounting plate that easily fits any junction box or surface with hanging hook wire that allows for hands-free installation when making electrical connections.

### FINISH

Fade, weather, and abrasion resistant, electrostatically applied, thermally cured, triglycidal isocyanurate (TGIC) textured polyester powder-coat finish on back housing, with impact and weather resistant polycarbonate front housing and lens.

### WARRANTY

Fixture is covered by a 5-year limited warranty.

See [probrite.com/warranty](http://probrite.com/warranty) for details.

## PRODUCT LINE DRAWING

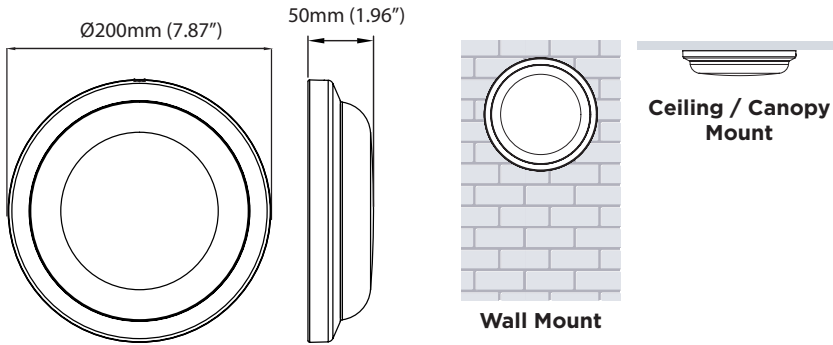

**SUGGESTED MOUNTING HEIGHT:**  
8-12FT.(2.4-3.6M)

## 2D PHOTOMETRIC VIEW

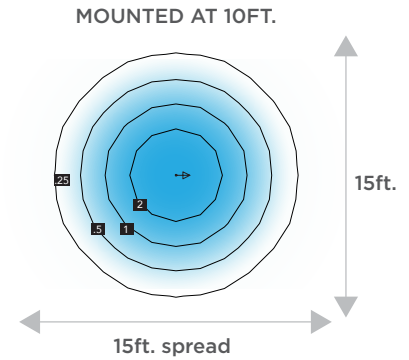

## PRODUCT SPECIFICATIONS

Product Dimensions	: 07.87" x 1.96"
Weight	: 1.21lbs
Lumens	: 900
System Wattage	: 12W
LED Wattage	: 11W
Efficacy	: 75
CRI	: 80
Replaces (MH)	: 75W
Mounting	: Wall/Ceiling mount
Frequency	: 50-60Hz
THD (Total Harmonic Distortion)	: <20%
PF (Power Factor)	: >0.9
Ambient Operating Temperature	: (-30) - 40°C
Input Voltage	: 120V
LED Chip	: Philips® LED
Photocell	: No
Driver	: Non-dimming
Standard Lifetime	: L70 >50,000hrs
Standard Warranty	: 5 Years
Water Proofing Grade	: Suitable for Wet location
CCT	: 3000K
Certifications	: UL/cUL

## APPLICATION

