

UNIT DESCRIPTION
 2 DOOR / 2 DRAWER CABINET

ASSEMBLED DIMENSIONS (H X W X D)
 74-1/4" X 35-11/16" X 15-3/8"
 188.7cm X 90.6cm X 39.1cm

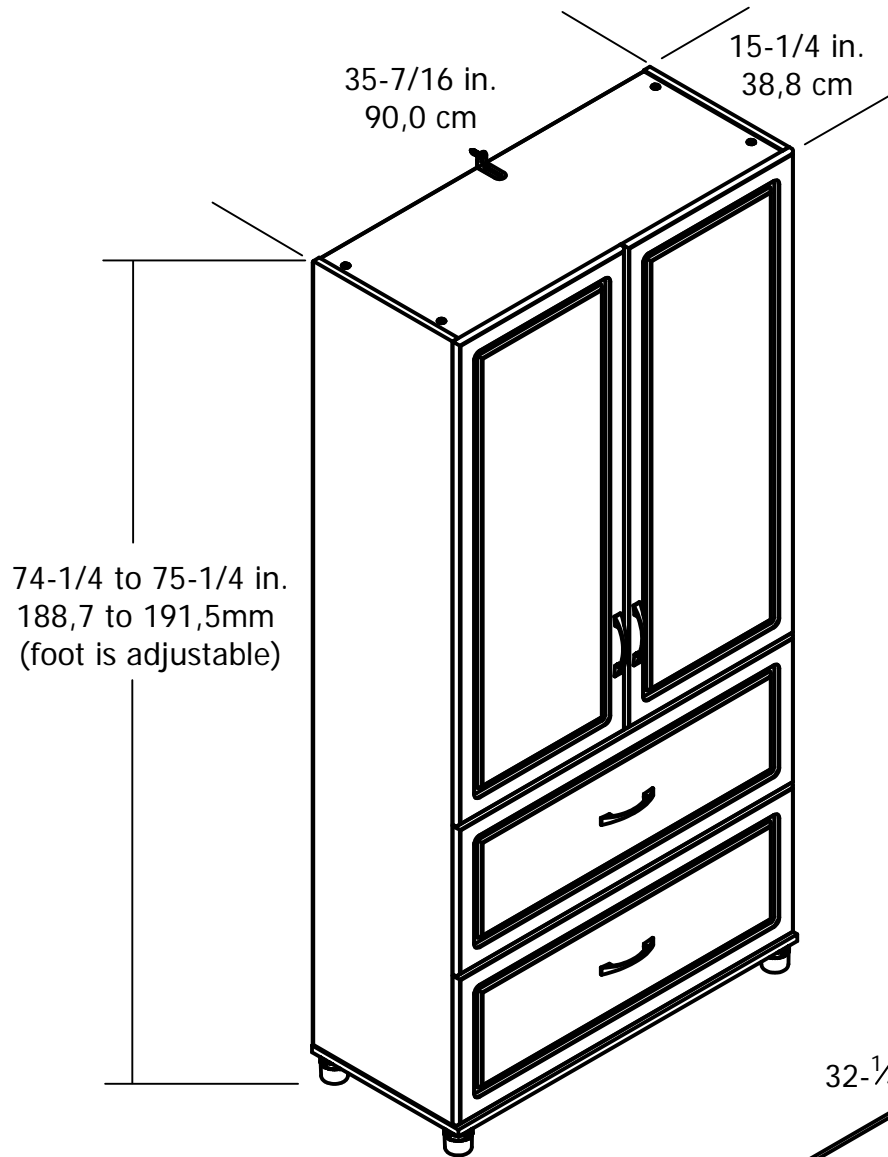

Adjustable Shelf:
 34-1/8" wide
 14-1/2" deep

Shelf:
 34-1/8" wide
 14-1/2" deep

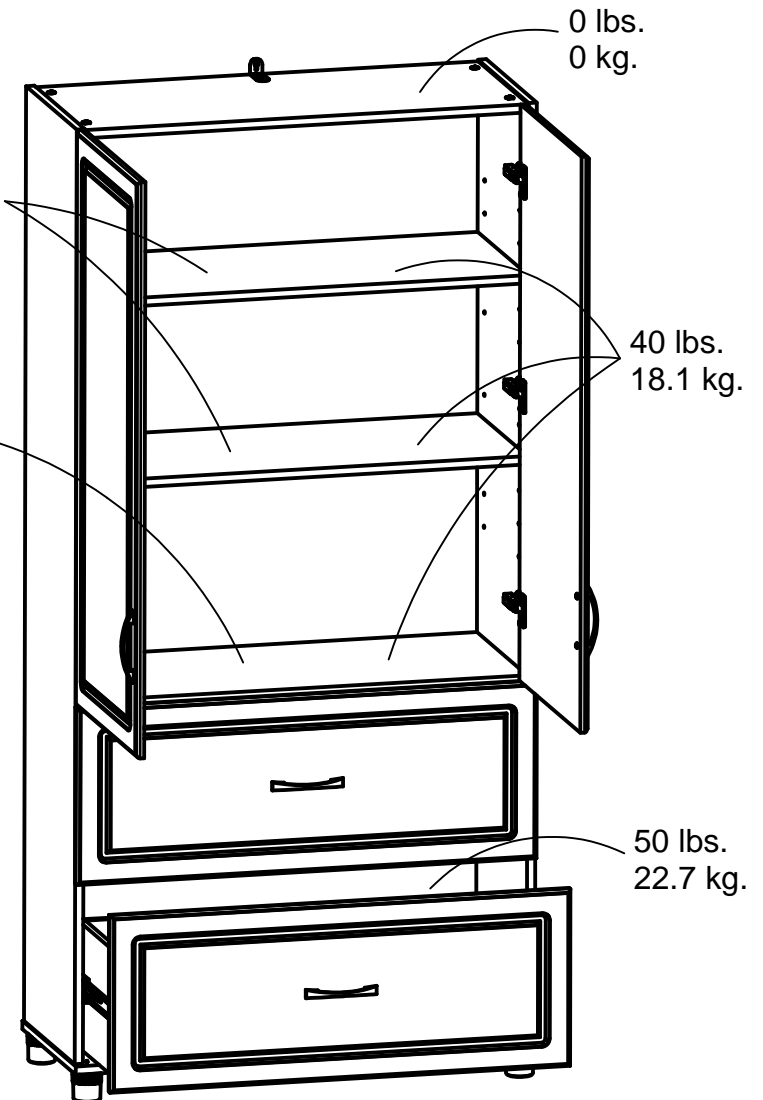
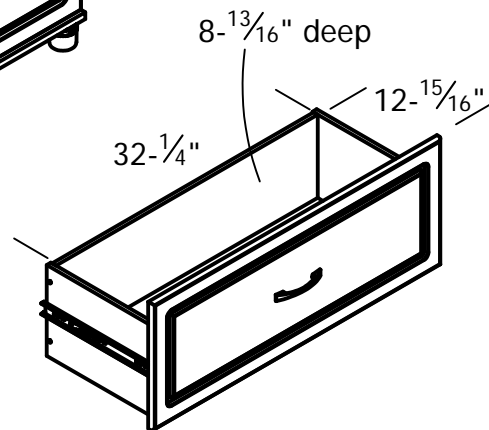

FINISH: (401) WHITE AQUASEAL
 (403) ONTARIO WHITE (DRAWER FRONT)
 WEIGHT: 148 LBS (67.13 KG)