

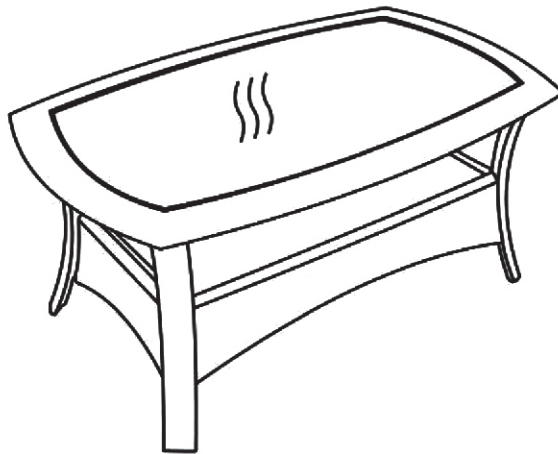

Strathmere Coffee Table
Owner's Manual



If you have any problems with this product, DO NOT RETURN IT TO
THE STORE. CALL OUR CUSTOMER SERVICE HOT-LINE at
866-391-4908
8am-5pm (EST), Monday-Thursday, 8am-4pm(EST), Friday

WARRANTY

In order to activate your warranty please register at www.bjifurniture.com. There you can review our full warranty details and other helpful information. Or, you may call us at (866) 391-4908, 8am - 5pm (EST), Monday – Thursday, 8am – 4pm (EST), Friday.

Care and Maintenance

Be careful to never allow water to build up in frames as this will cause corrosion and freeze damage in cold climates. Wash all frames with a solution of mild soap and water. Rinse with clean water and dry with a soft absorbent cloth towel. Frames can be treated with a liquid wax for maximum protection against UV rays and/or salty damp air. If your set includes cushions, slings, and/or an umbrella they may be cleaned by hand with a solution of soap and water with a clean water rinse. (Never machine wash cushions, slings or umbrella covers as this will result in shrinkage or damage).







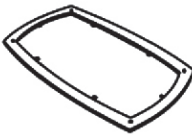

After cleaning cushions tip on end and allow to drip dry. (Never use a commercial or home dryer to tumble dry fabric goods). Do not use bleach or solvents to clean any product! This will void the warranty.

Lack of original receipt will void warranty!

CAUTION: Read all the instructions before assembly. Failure to do so may result in faulty assembly and potential injury! Assemble product on a soft, non-abrasive surface such as a carpet or cardboard to avoid damaging the item. Seek assistance to assemble bulky or heavy items. After final alignment, make sure all bolts and nuts are securely tightened with screw head covers pressed in place.

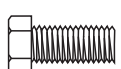
NOTE: Do not allow children to play with plastic wraps or small parts to prevent potential choking hazard.

PARTS LIST

PART#	DESCRIPTION	PICTURE	Q'TY
A	Table Rim with Glass		1
B	Table Leg		4
C	Short Leg Connector		2
D	Long Leg Connector		2
E	Leg Connecting Plate		1
F	Bolt M6x15		20
G	M6 Washer		20
H	Bolt Cap		20
I	Open Wrench		2

Assembly Steps:

Note: Do not fully tighten bolts until assembly is completed and alignment is correct.

Step 1. Take the glass top away from the table rim and place the glass top on a soft surface.

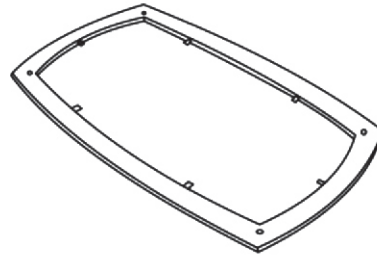

Figure 1

Step 2. Carefully place the table rim(A) upside down on a non-abrasive surface(See figure 1).

Step 3. Assemble the table legs (B) to the table rim (A) with bolts (F) and washers (G) by using open wrench(I) as shown in figure 2.

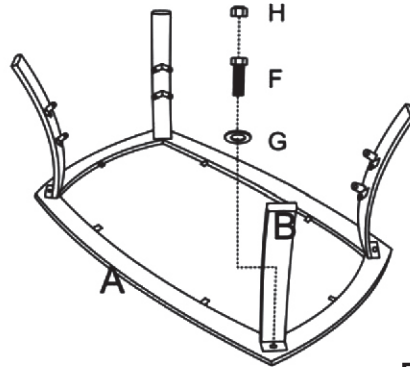

Figure 2

Step 4. Assemble the short leg connector (C) to the table legs (B) with bolts (F) and washers (G) by using open wrench(I) as shown in figure 3.

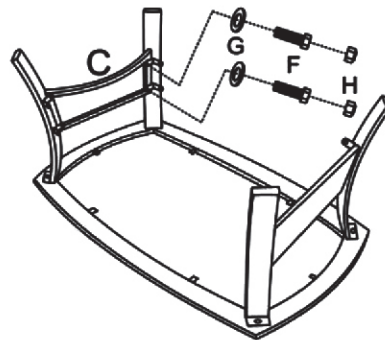

Figure 3

Step 5. Then assemble one of the long leg connector (D) to the table legs (B) with bolts (F) and washers (G) by using open wrench(I) as shown in figure 4.

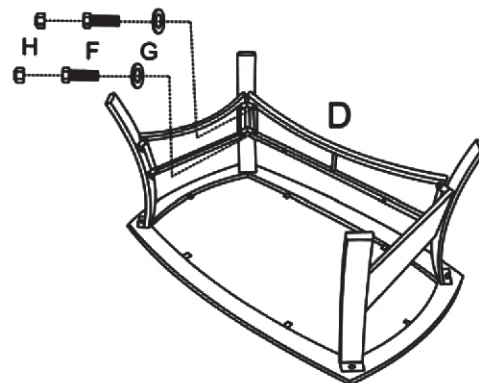

Figure 4

Step 6. Insert the leg connecting plate(E) to the one of the long leg connector. as shown in figure 5.

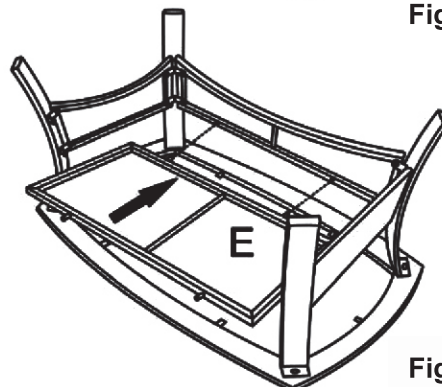

Figure 5

Step 7. Then insert the leg connecting plate to the other long leg connector(D) and at the same time assemble the long leg connector to the table legs with bolts(F) and washers(G) as shown in figure 6

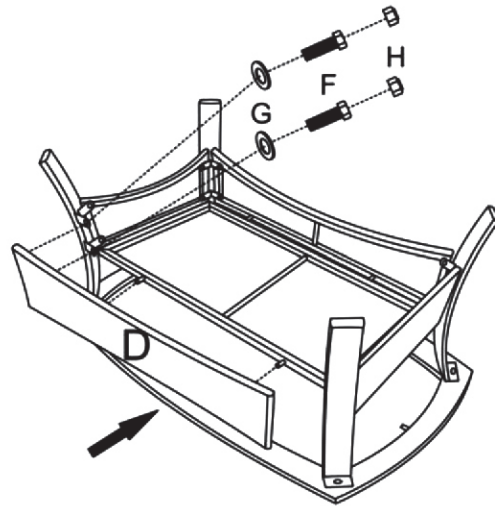

Figure 6

Step 8. Check the alignment and adjust if necessary. Once the alignment is correct, tighten all bolts with open wrench(I). Cover all bolts with bolt caps (H).

Step 9. Verify all bolts are securely tightened before use and turn your table right side up.

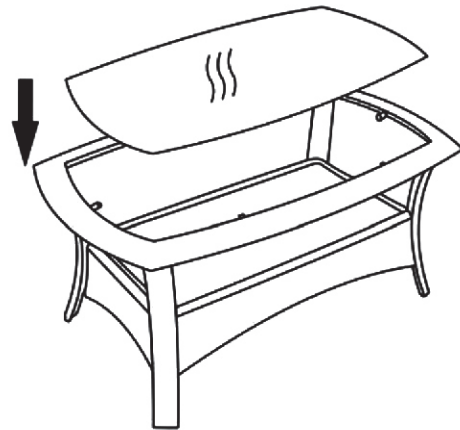

Figure 7

Step 10. Place the glass top on the table rim (See Figure7). Your table is now ready to use.

Warning:

- a.. Do not crawl, stand, or sit on glass table tops.
- b.. Do not set or lay heavy items on glass table tops.
- c.. Avoid extreme hot & cold items being placed on glass table tops.
- d.. This glass table top is produced with tempered glass which is designed to safely shatter in small pieces when impacted or stressed beyond strength limitations.



Strathmere Loveseat
Owner's Manual

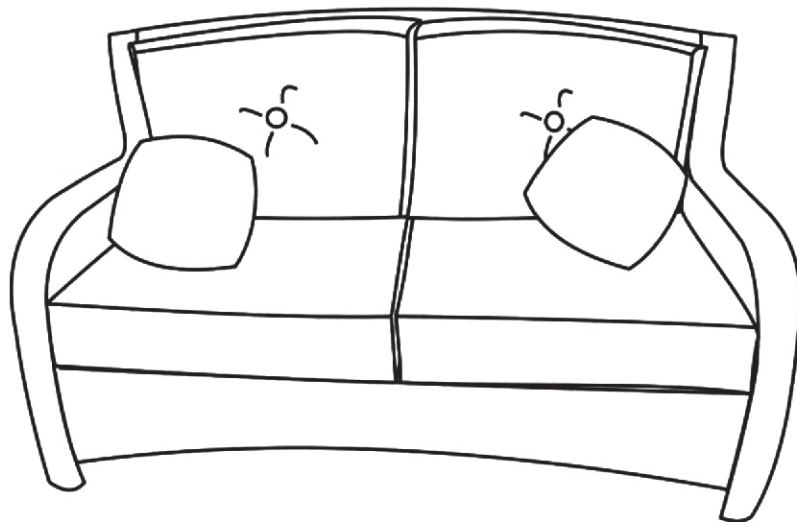

If you have any problems with this product, DO NOT RETURN IT TO
THE STORE. CALL OUR CUSTOMER SERVICE HOT-LINE at
866-391-4908
8am-5pm (EST), Monday-Thursday, 8am-4pm(EST), Friday

WARRANTY

In order to activate your warranty please register at www.bjifurniture.com. There you can review our full warranty details and other helpful information. Or, you may call us at (866) 391-4908, 8am - 5pm (EST), Monday – Thursday, 8am – 4pm (EST), Friday.

Care and Maintenance







Be careful to never allow water to build up in frames as this will cause corrosion and freeze damage in cold climates. Wash all frames with a solution of mild soap and water. Rinse with clean water and dry with a soft absorbent cloth towel. Frames can be treated with a liquid wax for maximum protection against UV rays and/or salty damp air. If your set includes cushions, slings, and/or an umbrella they may be cleaned by hand with a solution of soap and water with a clean water rinse. (Never machine wash cushions, slings or umbrella covers as this will result in shrinkage or damage).

After cleaning cushions tip on end and allow to drip dry. (Never use a commercial or home dryer to tumble dry fabric goods). Do not use bleach or solvents to clean any product! This will void the warranty.

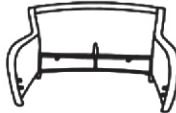
Lack of original receipt will void warranty!

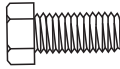
CAUTION: Read all the instructions before assembly. Failure to do so may result in faulty assembly and potential injury! Assemble product on a soft, non-abrasive surface such as a carpet or cardboard to avoid damaging the item. Seek assistance to assemble bulky or heavy items. After final alignment, make sure all bolts and nuts are securely tightened with screw head covers pressed in place.

PARTS LIST

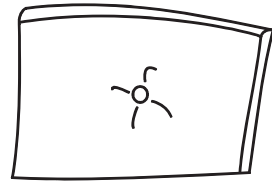
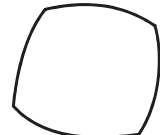
PART	DESCRIPTION	PICTURE	QTY
A	Seat Frame		1
B	Seat		1
C	Bolt M6×15MM		6
D	M6 Washer		6
E	M6 Bolt Cover		6
F	Open Wrench		2
G	Seat Cushion		2
H	Back Cushion		2
I	Toss Pillow		2

Assembly Steps

Step 1. Place the seat frame (A) on a flat surface.
(Figure 1)

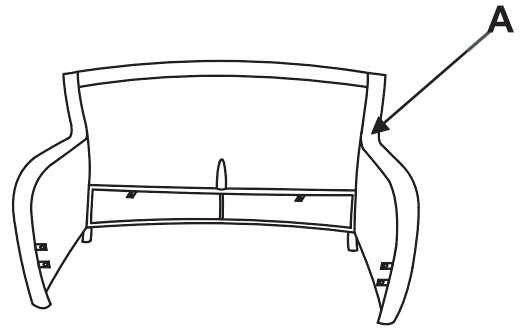

Figure 1

Step 2. With the help of another person, carefully place the seat (B) into the seat frame. Connect the seat to the seat frame with bolts (C), washers (D) by using open wrench (F), then cover the bolts with bolt covers (E) as shown in figure 2.
(Figure 2&3)

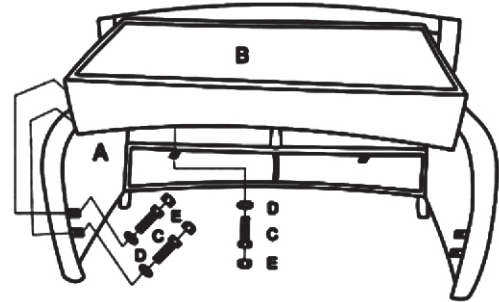

Figure 2

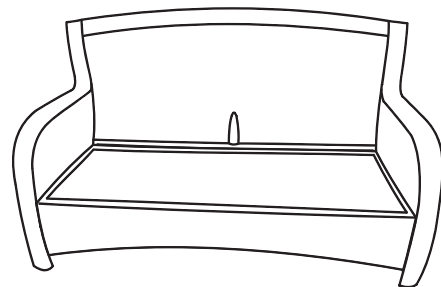

Figure 3

Step 3. Place the seat cushions (G), back cushions (H) and the toss pillows (I) on the seat.
Your loveseat is now ready to use.
(Figure 4)

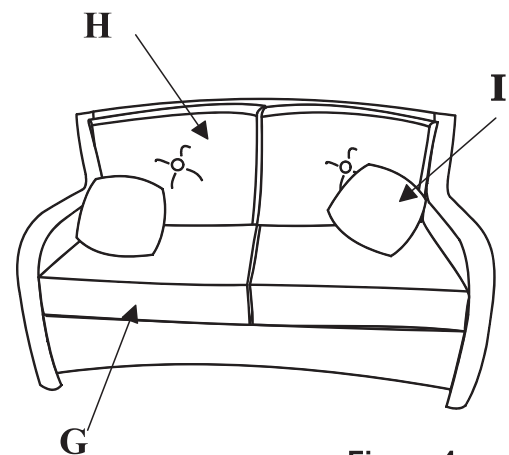

Figure 4