

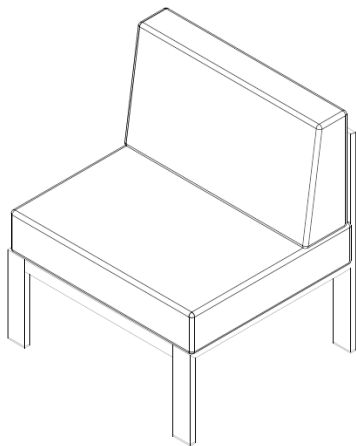



Thank you for purchasing the **MODWAY ARMLESS CHAIR!**

Before you start, here is some helpful advice:

1. We suggest you spend a short time reading through this leaflet and then follow the simple step by step instructions.
2. Owing to the size and weight of the chair, we recommend that it is assembled by two adults, on a carpeted or padded area, in the room that it is intended for. Approx assembly time: 30 minutes.
3. Please do not use any tools other than those provided or recommended in these instructions.
4. Please do not throw away any of the packaging or the instruction until you have checked all the components and hardware and the furniture is fully assembled. Please ensure that the packaging is disposed of in a safe environmentally friendly way.
5. Assemble all components loosely until advised to tighten. Depending on use, it may be necessary to tighten the components from time to time, so please save the tools that has been provided.
6. Please keep all fitting out of reach of children.



Hardware:

A		Bolt M6x20mm	x4
B		Bolt M6x25mm	x6
C		Allen Wrench M4	x1

Component:

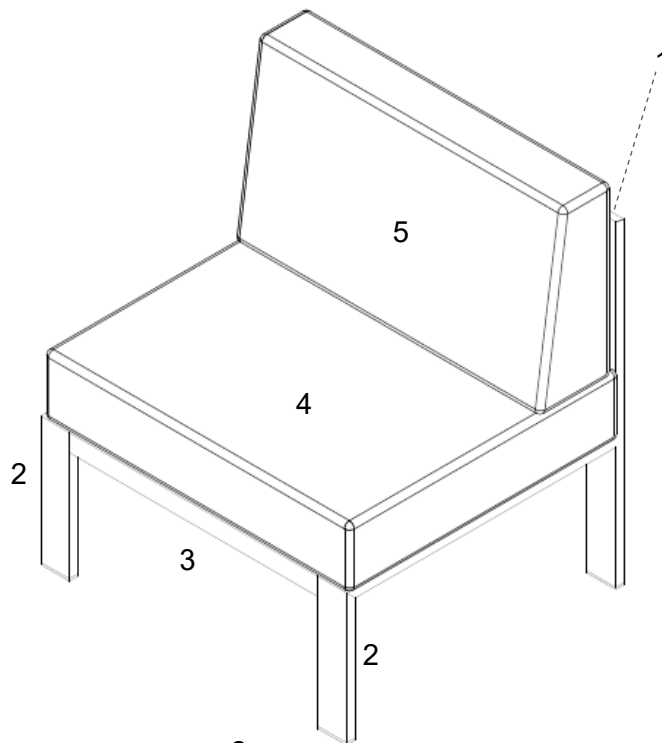

1	Top Rail	x1	2	Leg	x2	3	Seat Frame	x1
4	Seat Cushion	x1	5	Back Cushion	x1			

STEP 1:

Remove the plastic covers which pre-install in the end of the **Seat Frame (3)** by using **Allen Wrench (C)**.

Please put 1 piece of **Leg (2)** on a carpeted or padded area.

Insert **Top Rail (1)** and **Seat Frame (4)** into the **Leg (2)** as shown.

Insert 3 pieces of **Bolt (B)** from the pre-drilled holes on the bottom of the **Top Rail (1)** and **Seat Frame (4)** into each side on the bottom of **Leg (2)**.

Insert 2 pieces of **Bolt (A)** from the pre-drilled holes on the side rail of the **Seat Frame (4)** into each end of the **Leg (2)** as shown.

Do not fully tighten **Bolts (A&B)** at this step.

Repeat the same steps for the remaining 1 piece of **Leg (2)**.

After checking the leveling for all connections, please use **Allen Wrench (C)** to tighten all **Bolts (A&B)** clockwise until secure.

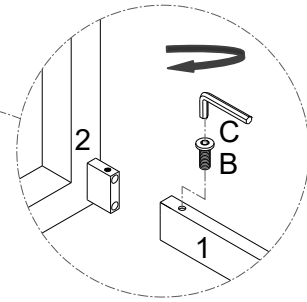
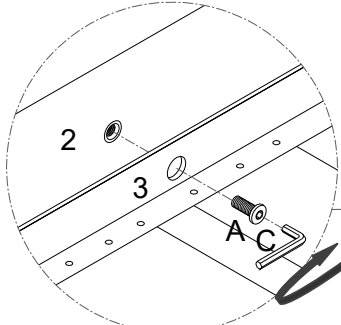

The bottom of seat frame and legs

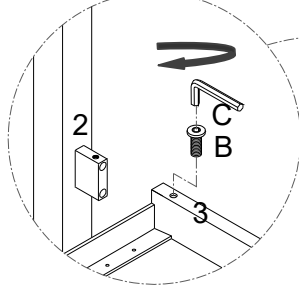

The bottom of seat frame and legs



The bottom of top rail and legs

		
Ax4	Bx6	Cx1

Hardware & Tool required

STEP 2:

Carefully place the assembled chair at your desired position.

Put the **Seat Cushion (4)** and **Back Cushion (5)** to assembled chair frame as shown.

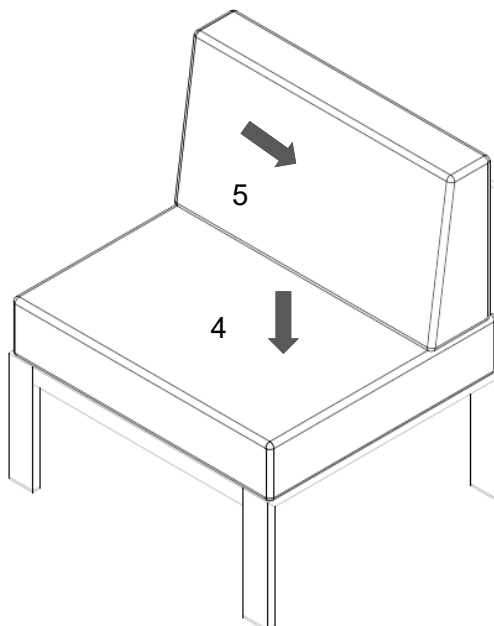

Assembly is completed. The chair is ready to enjoy now!