



bluworld
HOMelements

WATER WONDERS®

Classic
Quarry
EXOTIC STONE FOUNTAINS

CLASSIC QUARRY NOJOQUI & HORIZON FALLS Installation Manual



IMPORTANT – RETAIN FOR FUTURE REFERENCE – READ CAREFULLY

- Try to position your fountain above or near an electrical outlet.
- When considering the location of your fountain, please consider making it easily accessible for maintenance (e.g. adding water, cleaning etc.). Avoid delicate surfaces that could be damaged by splashing.
- Consider the surface on which your waterfall will be placed. This feature can be mounted on sheetrock with wood studs, tile, brick or concrete. (No mounting hardware is included for masonry installations). Due to the weight of this fountain, it is necessary to mount directly into at least one wood stud. You **MUST** use the provided EZ Anchors™ (J) for any screw that does not hit a stud.
- Mount indoors only. It is not recommended to place your fountain in direct sunlight.
- **** It is critical that your waterfall is level as this will ensure even water flow. ****
- **Assemble as near as possible to the point of installation. Take extreme care when lifting to avoid personal injury or damage to the product.**
- This product contains small items and plastic bags. Please be aware of the danger to young children.
- Assistance in mounting your fountain is required. You will need 2-3 people.

Parts List Not Shown - Classic Quarry Stone



A. Bracket Template 1 each

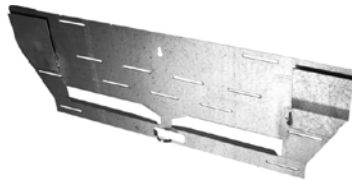

B. Stone Wall Bracket 1 each



C. Remote 1 each

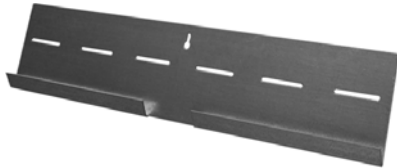

D. Reservoir Wall Bracket 1 each



E. Water Dispenser 1 each

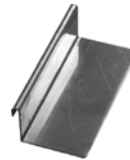

F. Water Diffuser 1 each



G. Trim Kit (your color may be different) 1 each



H. Pump Assembly w/Flow Valve 1 each



I. River Rocks 1 each



J. Hardware Bag with scrubby pad

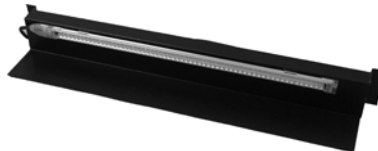

K. LED Light Kit with cord 1 each

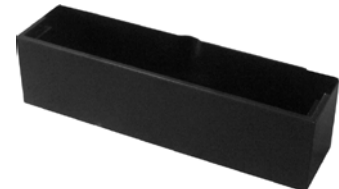

L. Reservoir 1 each



M. Pocket Clips 2 each



N. Rock Tray 1 each



O. EVA Reservoir Pads 2 each

Section 1: Initial Prepping

- Carefully remove and inspect all your Classic Quarry components from its shipping carton. **Do not install or operate unit if any parts are damaged. Please retain all packaging until your unit is installed correctly and running successfully. You may leave the stone on the pallet until ready to hang.**
- It is very important to rinse your stone clean of any dust or chips that may have accumulated during shipping prior to assembling your fountain.
- Tools required: Level, Pencil, stud finder, drill with Phillips bit, Phillips Screwdriver, and Measuring Tape.
- The use of distilled water is strongly suggested You will need 5 gallons of distilled water for Nojoqui Falls and 5 gallons for Horizon Falls.

Section 2: Mounting the Wall Brackets

1. Your Nojoqui Falls fountain is 58" tall x 25.5" wide the Horizon Falls fountain is 33" tall x 51" wide. Determine where on the wall the fountain will be mounted. You may wish to block out the dimensions with low tack or painters masking tape for reference. The fountain must be mounted into studs, wood or metal. Using the stud finder locate and mark the position of the vertical and horizontal studs within the blocked out installation area. Once the studs have been located, the brackets can be installed.

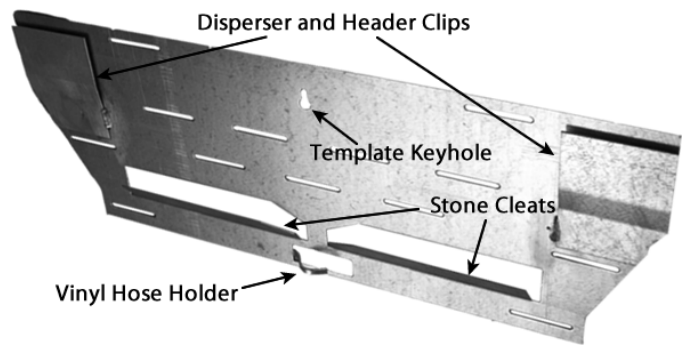

2. Mark the center of the fountain's width (Nojoqui Falls is 12.75" - half the 25.5" overall fountain width) and (Horizon Falls center is 25.5" - half the 51" overall width) for reference. Using your level mark this line vertically within the installation area.

3. Identify the Bracket Template (A) from the fountain components. The top of the bracket (A) will rest exactly 4" down from the overall height of your fountain. Using the center mark of the fountain's width place the Bracket Template's (A) upper keyhole so you can see the center line through the hole. The keyholes should be in this position (Fig 2.1). Mark the top keyhole.



4. Using a Phillips screw driver and a small screw from your Hardware Bag (J) set the screw in the wall so that 1/4" is left protruding. Hang the Bracket Template (A) from this screw (Fig 2.2) making certain the keyhole is in the position shown in Fig 2.1.

5. Using the level make certain the Bracket Template (A) is vertically level and mark the placement of the lower keyhole. Remove the Bracket Template (A).

6. Again using a Phillips screw driver and a small screw, set the screw in the lower keyhole mark so that 1/4" is left protruding.



Fig 2.2



Fig 2.3



Fig 2.4

7. Hang the Stone Wall Bracket (B) from the center keyhole on the upper screw. Note the position of the marked wall studs through the numerous bracket holes. (Fig 2.3)

8. Place the level on the top of the Stone Wall Bracket (B) insuring it is level (Fig 2.3). Mark the holes that align with the wall studs. The ideal bracket installation would include screws located at the bracket's left top and bottom, right top and bottom and center. If you do not have studs at these locations you will need to use the EZ Anchors™ (J) to complete the Stone Wall Bracket (B) installation at these locations. Remove the keyhole screw as it will interfere with the installation of the stone.

9. Repeat this procedure for the Reservoir Wall Bracket (D) (Fig 2.4). Remove the keyhole screw when finished.

Section 3: Mounting the Reservoir and Water Dispenser

1. Locate the reservoir (L) and the EVA Cushion Strips (O). Peel the paper off the adhesive strip and place each pad about 1" up from the bottom of the reservoir and 2" in from each side as shown in the drawing (Fig 3.1).

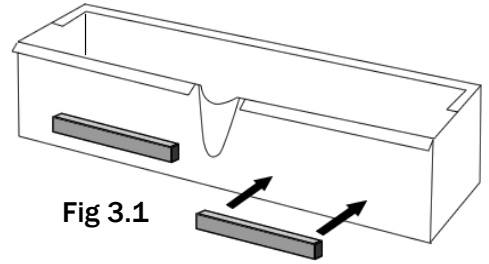

Fig 3.1

2. Hang the reservoir (L) on the reservoir wall bracket (D). Make certain the reservoir (L) is well seated and centered on the bracket (Fig 3.2).

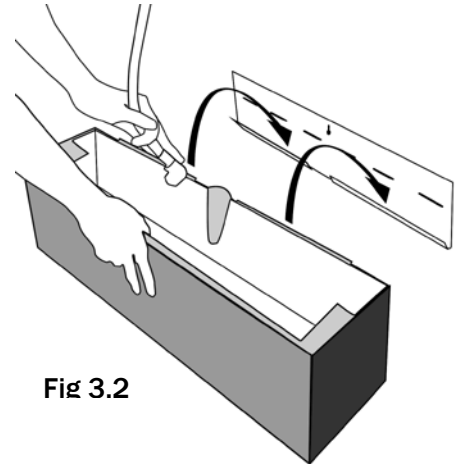

Fig 3.2

3. Place the pump assembly (H) inside the reservoir (L) close to the right edge. **DO NOT plug the pump (H) into an outlet. Operating the pump dry will void any warranty and burn out the pump.**

4. The water dispenser (E) will sit in the bracket pockets on the stone wall bracket (B). Until the stone is mounted it will need to be placed temporarily above the bracket so the stone can be positioned on the bracket cleat. Place one Pocket Clip (M) inside each of the wall bracket pockets (B) (Fig 3.3). The curved end of the Pocket Clip should be up and facing the wall. Next slide the tabs on the dispenser (E) behind each Pocket clip (M) so it is holding up the dispenser (E) (Fig 3.4); you may need to pull the clip out from the wall to slide the tab behind as it should be a very tight fit. Do not push the dispenser (E) all the way down; just enough so that it doesn't fall.

5. Place the vinyl tubing inside the tube clip. It should be loose so the tube can slide freely up and down when the dispenser is moved.

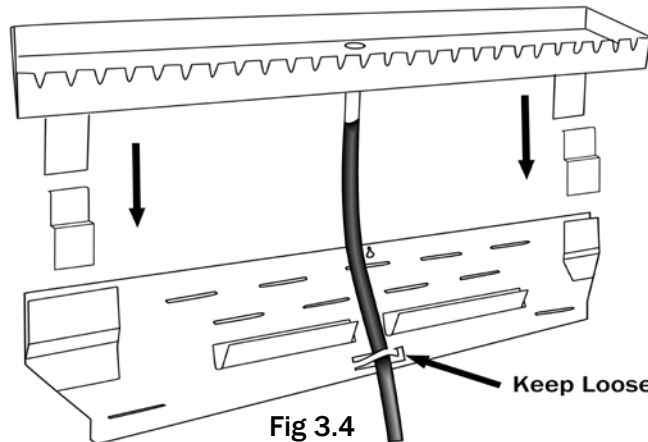

Fig 3.4

6. Make certain the vinyl tubing and plumbing hang straight down into the reservoir.

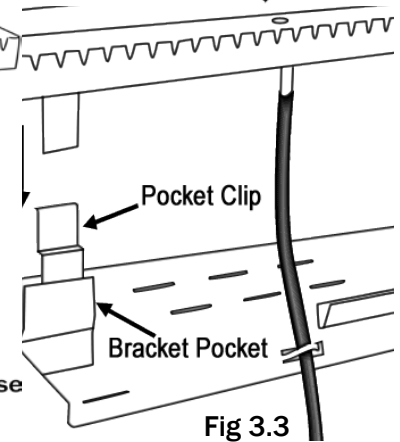
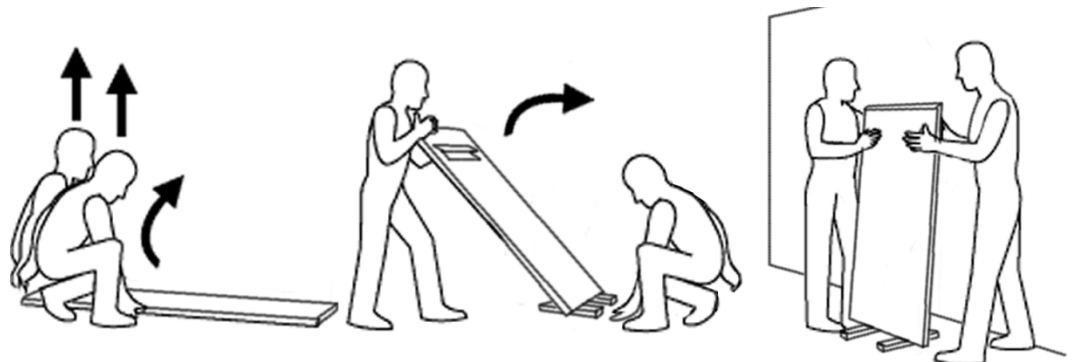

Fig 3.3

Section 4: Mounting the Stone

1. Remove the stone from the box. Due to the weight you will need 1 or 2 people to assist with the installation. Your stone ships face down. Notice the bracket that has been anchored to the back of the slate. This will hook onto the cleat of the stone wall bracket (B). The cut angle is the top of the stone. Using two strong people lift the slate up

from the pallet and carefully move the stone to the installation area. Position the stone so it is centered in front of the reservoir (L). You may wish to rest the stone on scrap wood so you can grip under the stone when lifting to mount it on the bracket.



2. It is a good idea to have someone spot you on the position of the bracket and to see if you are centered or not inside the basin. Lift the stone up just past the mounting cleat and tip the top back so it is just under the disperser (E) and then tilt the bottom back towards the wall clearing the reservoir lip. Lower the stone until it engages the cleat. Make certain the stone is well seated on the cleat and centered from left to right inside the reservoir (L).

Section 5: Setting the Disperser and Diffuser

1. Gently lift the disperser (E) from behind the Pocket Clips (M) and remove each Pocket Clip out of the Wall bracket pocket (B). Slide the tabs on the disperser (E) behind the stone and into the bracket pockets on the wall bracket (B) (Fig 5.1). The disperser (E) should sit evenly along the angle on the stone edge. Press the disperser (E) down firmly to ensure there are no gaps between it and the stone. Center the Disperser (E) from left to right on the stone. You may want to keep the Pocket Clips should you need to install your fountain in a new location.

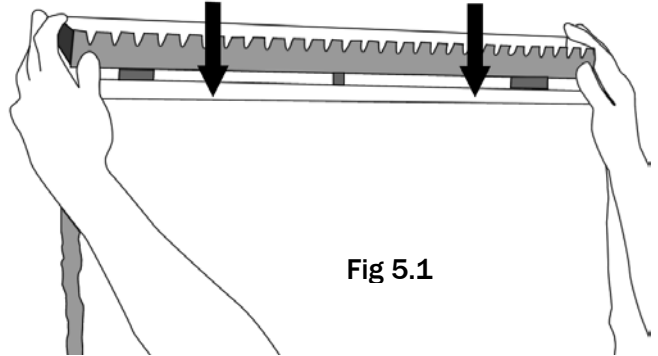

Fig 5.1

2. Drop the water diffuser (F) directly over the center of the disperser hole (Fig 5.2). The diffuser (F) will clip on the back edge of the disperser (E). Make certain the diffuser (F) is sitting directly over the hole (Fig 5.2).

3. During the mounting of the stone the plumbing tubing and connection may have moved behind the stone. Gently lift the bottom edge of the stone forward and pull the plumbing down so it is resting in the reservoir (L). The vinyl tubing should be inside the rounded bump out in the reservoir (L) so the weight of the stone does not pinch it closed.

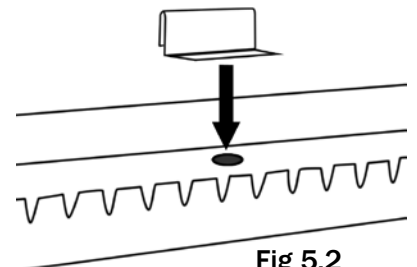

Fig 5.2

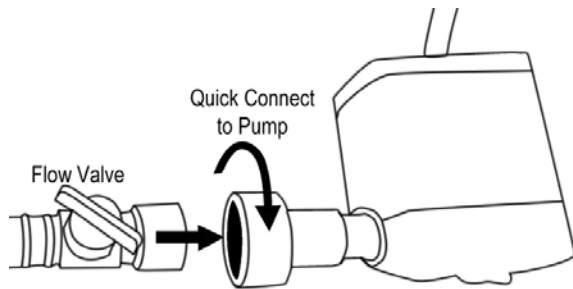

Fig 5.3

4. Connect the pump (H) to the plumbing using the quick connect fitting (Fig 5.3). The flow valve **should** be open. Open is when the valve is in line with the plumbing. Closed is in perpendicular position.

perpendicular position.

Section 6: Installing the Header and Shroud

1. Locate the Header and Shroud (G). Install the Header by simply sliding it into the support pocket clips located on the stone wall bracket (B). It may be a very tight fit so you may need to pull the disperser forward to allow for the header to slide down into the clip (Fig 6.1). Take a few steps back looking at the fountain and make certain the header is sitting level.

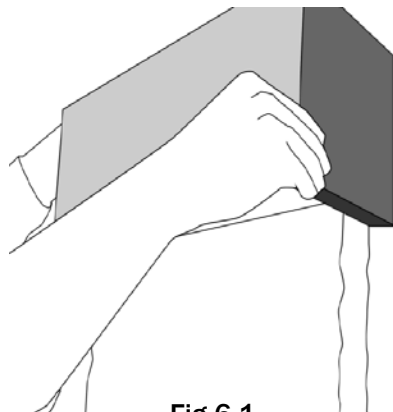

Fig 6.1

2. Install the Shroud by carefully sliding it behind the panel and down onto the reservoir (L) (Fig 6.2).

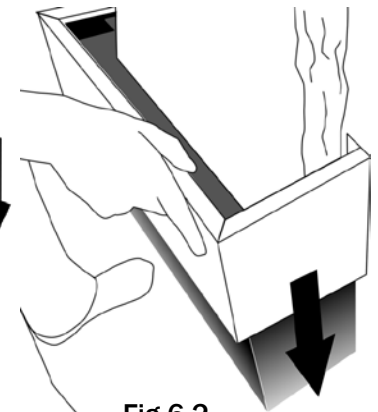

Fig 6.2

Section 7: Installing the Light Kit

1. Carefully unwrap the LED light bar (K). Take care in handling so that the LED strips and connections to transformers are not disturbed. Remove the tie from the electrical cord.
2. Place the LED light bar (K) inside the header (G) with the LED strip facing down (Fig 7.1). It is designed to simply rest on the header held up by the 2 tabs located on either side of the light bar (G). The back of the light kit hangs down covering the castellated stainless steel disperser (E). Make certain it does not interfere with the water flow and does not touch the disperser (E).
3. Take the light cord and plug it into the transformer (Fig 7.2). Drape the cord through the header (G) and down the side where you will plug it in. Tuck the exposed cord behind the stone so it is concealed.
4. You are now ready to use your LED light bar.

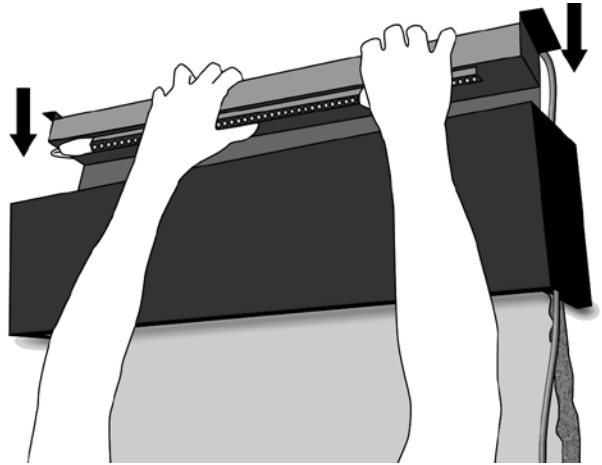

Fig 7.1



Fig 7.2

Section 8: Operating the Waterfall

1. After mounting your fountain to the wall, fill the reservoir (L) with water (distilled water is strongly recommended). The water level must be maintained at least 1/2" above the pump. If the water level drops below the pump, splashing and damage may occur.
2. Before turning on your fountain for the first time make certain the flow adjustor is not closed, having the flow valve in a closed position puts excessive pressure on the pump and may cause it to overheat and break. The flow valve lets you increase or decrease the amount of water flowing over the waterfall (Fig 8.1). You will need to adjust the flow valve to the proper rate for solid water coverage but not so fast that it causes splashing. Turn the flow valve down if the pressure is too strong and splashing occurs.
3. Plug in the pump cord. As water begins to flow down the surface there may be dry spots. Starting at the top guide the water with your hand or sponge over the dry areas pulling the water streams together until the water flows evenly over the entire waterfall surface. It may take a few minutes.
4. If after turning down the flow you may still notice small splashing. This may be caused by a hard edge on the stone surface and the water is kicking off this edge. This is easily corrected. Note where the water is splashing from on the stone and turn off the pump. Take a small chisel or flat head screw driver and gently smooth or ease the hard edge down where the water is jumping off. Be careful to not gouge the fountain surface. Once smooth the water will be less likely to jump off and splash.
5. Install the Rock Tray (N) and spread Rocks (I) equally throughout the tray. Do not sit or pile any stones up against the stone slab as this may cause minor splashing.

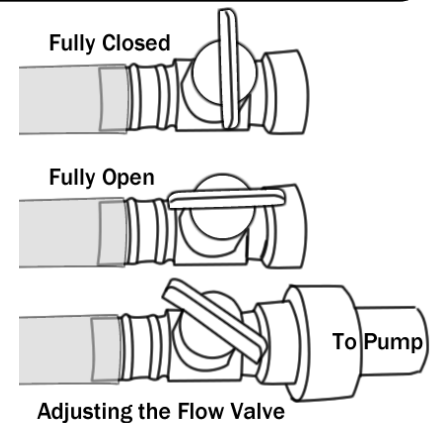
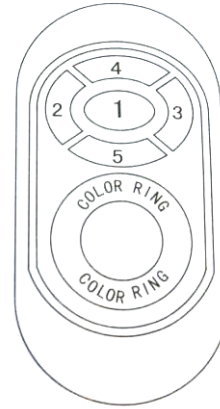

Fig 8.1

RF Wireless Touching LED Remote Controller (Color Adjusting)

1. Technical Parameters (remote control):

- Power supply: AAA battery*3pcs
- Working voltage: DC 12V/24V
- Cover material: ABS
- Fabrication processing: multicolor printing & UV varnish
- Output control: 3circuits (R/G/B)
- Control current: 6A/circuit
- Connecting method: common anode
- Dimension: L85*W64*H24
- Receiving range: 20meters



2. Functions of Keys

- Key 1: on/off
- Key 2: light changing mode (15 modes)
- Key 3: color light/white light switching mode
- Key 4: turn up (brightness/speed)
- Key 5: turn down (brightness/speed)

3. How to use

- Press Key 1 to turn on/off in any state.
- Press Key 2 to activate light changing mode. A new mode each press, 15 modes in total.
- Press Key 3 once to activate while light mode, changing brightness by pressing Key 4/Key 5. Press Key 3 twice to activate color light mode, changing brightness by pressing Key 4/Key 5 or changing light color by touching the color ring.
- Resume function. The previous setting will be resumed while power on again.
- Matching code: Press Key 4 once within 3 seconds when power on again, the light will blink 3 times if matching is successful.
- Cleaning code: Press Key 4 five times within 3 seconds when power on again, the light will blink 6 times if clearing is successful.

1	Auto color changing	8 grades of brightness to adjust by pressing Key 4 or Key 5
2	Three colors jumps to change	8 grades of speed to adjust by pressing Key 4 or Key 5
3	Seven colors jumps to change	
4	Three colors jumps to gradual change	
5	Seven colors jumps to gradual change	
6	Red color jumps to change	
7	Blue color jumps to change	8 grades of brightness to adjust by pressing Key 4 or Key 5
8	Purple color jumps to change	
9	Green color jumps to change	
10	Yellow color jumps to change	
11	Cyan color jumps to change	
12	White color jumps to change	8 grades of brightness to adjust by pressing Key 4 or Key 5
13	Red/Blue light twinkles alternately	
14	Green/Blue light twinkles alternately	
15	Red/Green light twinkles alternately	

4. Caution: Please don't touch or press the color ring while loading the batteries to protect the sensitiveness. Please use the remote controller 3 seconds after the batteries are loaded. Please reload the batteries when you find the color ring is not sensitive.

5. Connecting chart:

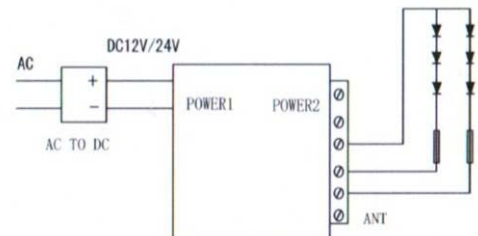

Warranty

Bluworld's Warranty has changed as of August 1, 2008 and supersedes all previous warranties for product purchased after August 1, 2008. If there is printed material within this shipment it is considered void and the Warranty as stated below is policy.

Bluworld products are warranted against defects that render it unfit for its reasonably intended use. This Warranty is not extended to cover use of the product for a purpose other than as intended, and if the product is used unreasonably, or for purposes other than as intended, or if it is altered, modified or repaired by a party other than Bluworld, then the Warranty shall be null and void. The Warranty is in effect for a period of six months beginning from the date of sale to the original retail purchaser and the rights under this Warranty are limited to the original retail purchaser. Bluworld will, upon written notification thereof, take commercially reasonable steps to correct such defects (see "manufacturers defects below"), at Bluworld's sole option, by suitable repair, replacement, or refund. Bluworld will not be responsible for the installation, labor or any other costs or expenses related to the re-installation of a warranted part, and such expenses are not covered by this warranty. THIS LIMITED WARRANTY IS EXCLUSIVE AND IN LIEU OF ANY IMPLIED WARRANTY OF MERCHANTABILITY, FITNESS FOR A PARTICULAR PURPOSE, OR OTHER WARRANTY OF QUALITY, WHETHER EXPRESS OR IMPLIED, EXCEPT FOR THE WARRANTY OF TITLE AGAINST PATENT INFRINGEMENT. Corrections of nonconformities, in the manner and for the period of time provided above, shall constitute fulfillment of all liabilities of Bluworld to any Dealer with respect to the goods, whether based on contract, negligence, and strict tort or otherwise. Bluworld contract sales personnel, including but not limited to authorized Dealers and Resellers (collectively, "Sales Personnel"), are not authorized to make warranties about Bluworld merchandise.

ORAL STATEMENTS DO NOT CONSTITUTE WARRANTIES. Oral statements made by Bluworld employees or other Sales Personnel shall not be relied upon by a Dealer and shall not become part of any contract for sale. The entire sales contract between a Dealer and Bluworld will be set forth in the invoice and/or accompanying or reference documents provided by Bluworld to the Dealer or Sales Personnel. No other warranties are given beyond those set forth in those documents. Please be aware that you may have valuable rights under the state law in which you reside. Some of the provisions of this Warranty may be prohibited by your state law in which case your state law will govern and control. Some states do not allow the exclusion or limitation of incidental or consequential damages, so the above limitation or exclusion may not apply to you. Some states do not allow limitations on how long an implied warranty lasts, so the above limitations may not apply to you. This Warranty gives you specific legal rights, and you may also have other rights which vary from state to state.

Our products are warranted for a period of six months against defects in finish, pumps and other product performance issues. Light bulbs are not warranted. Our experience has shown that in practically 100% of incidents that any defect is apparent within a week of installation and use. Appearance defects should be noticed upon unpacking the fountain. We have found that finishes have 'failed' due to poor maintenance, local water conditions with minerals affecting the finish, attempts to clean with harsh chemicals or abrasive pads being used. Performance of water flow, spitting, and other 'leaks' are usually caused by debris getting into the fountain, buildup of minerals, algae from poor water or lack of maintenance. Pumps can also fail due to water levels not being maintained in the reservoir and this is not covered by the warranty.

Manufacturers Defect defined - A distinct and obvious flaw in the manufacturing of the product that inhibits the product's ability to function properly or a distinct and obvious flaw in the workmanship of the product that affects its physical appearance. Bluworld water features are manufactured under generally accepted manufacturing techniques as recognized by the International Organization of Standardization. Our products are handmade and hand finished thus minor scratches in materials within accepted ranges are not considered defects.

Slate- Many of our products contain natural slate. Slate can vary to a large degree and that individuality is what is considered to be unique and inherent to the beauty of the natural product as no two are exactly alike. Photos in our marketing materials are representative of our slate products but should not be relied on to duplicate the photo. We use natural mined slate in our products. Personal taste in the appearance of slate is not considered a reason for a return.