

INSTALLATION MANUAL

Front Bumper Kit — 19A30020OEM

Model 19A30020OEM front bumper kit is designed for use with select lawn tractors. Refer to your lawn tractor's Operator's Manual to assure compatibility.

Carton Contents

Before beginning installation, remove all parts from the carton to make sure everything is present. Carton contents are listed below and shown in Figure 1-1. Part numbers are shown in parentheses.

- Two Bumper Caps (731-05368)
- One Bumper Assembly (683-05155)
- *Four Hex Flange Screws (710-06012A)

*Some Kits will have instead:

- Four Hex Screws (710-06012)
- Four Flat Washers (712-0262)

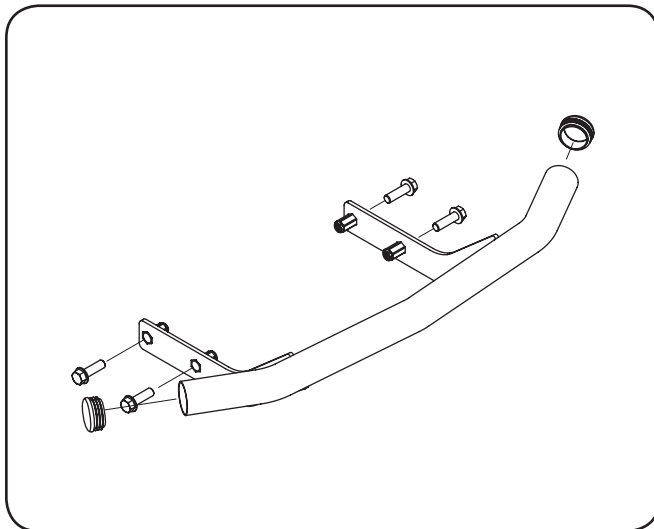

Figure 1-1

Installation Instructions



WARNING: Before beginning installation, place the tractor on a firm and level surface, set the parking brake, place the PTO in the disengaged (OFF) position, stop the tractor's engine and remove the ignition key to prevent unintended starting.

1. Place a bumper cap onto each end of the front bumper tube. See Figure 1-2.

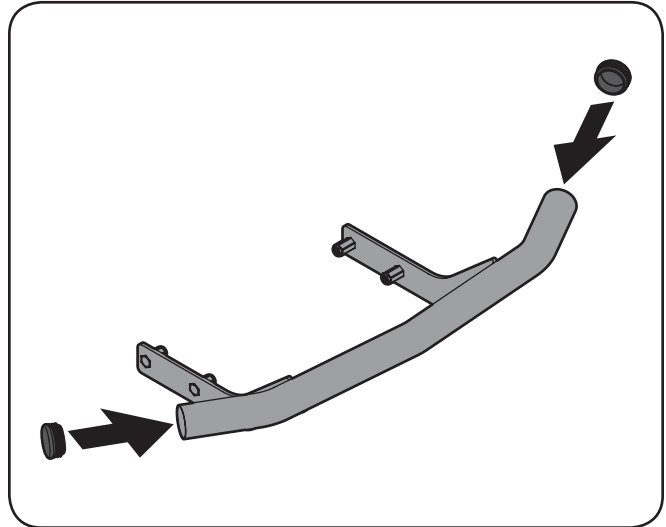

Figure 1-2

2. Position the bumper brackets to the *inside* of the tractor's frame and secure it in place with the four hex flange screws or four hex screws and four flat washers, depending on what this kit includes. See Figure 1-3.

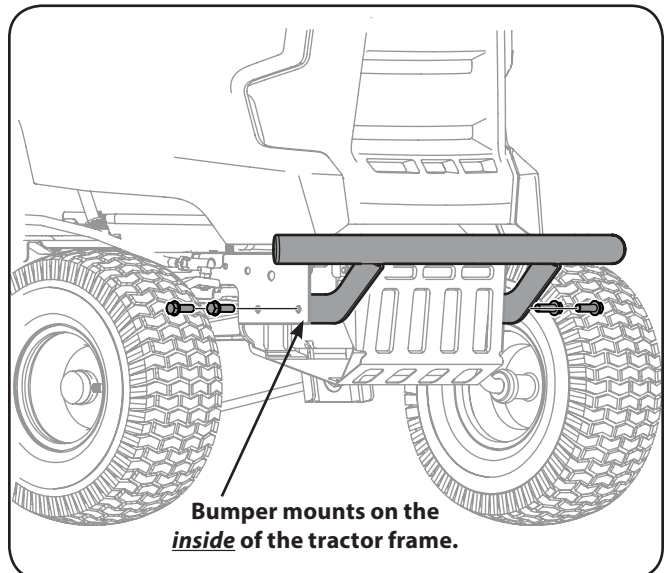

Figure 1-3

MTD LLC, P.O. BOX 361131 CLEVELAND, OHIO 44136-0019



To order replacement parts or locate your nearest service dealer call Customer Support at (800) 800-7310.
or visit www.mtdproducts.com to find the nearest authorized dealer in your area
