

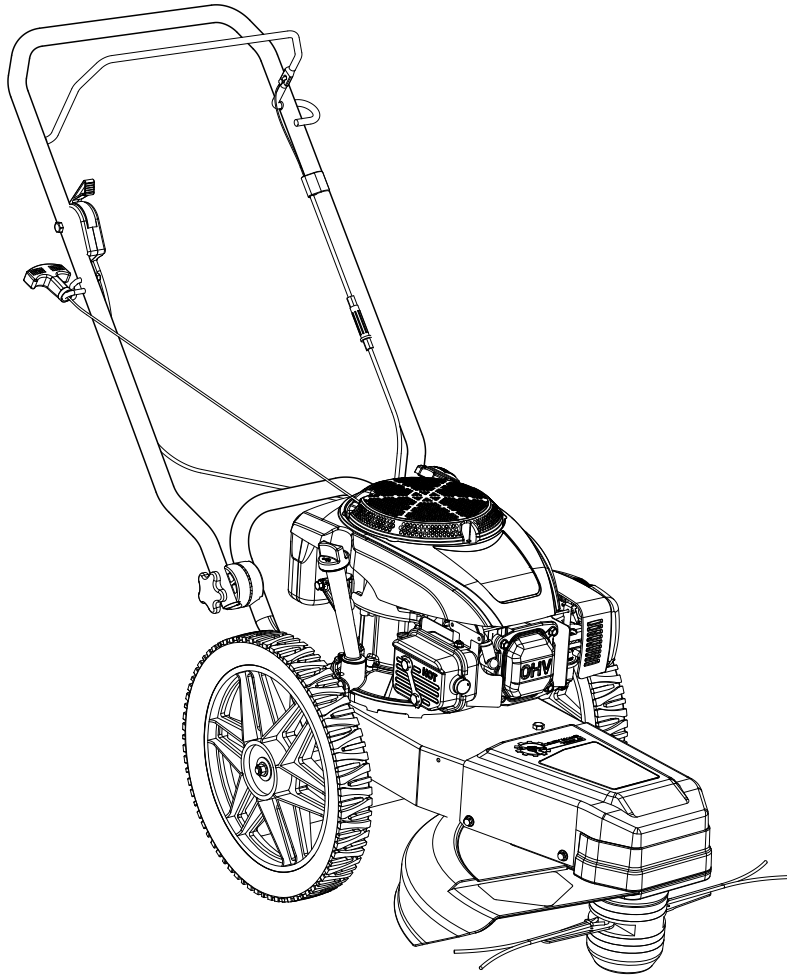

**DIRTY HAND  
TOOLS**

# Trimmer Mower



**MODEL # 101085**

# Operation Manual



**This safety alert symbol identifies important safety messages in this manual. Failure to follow this important safety information may result in serious injury or death.**

Part # 101550 Rev B



For Service or Questions

*Call 1-877-487-8275*

**720-287-5182**

*[www.dirtyhandtools.com](http://www.dirtyhandtools.com)*

Dirty Hand Tools® is a brand of



**FrictionlessWorld**

1100 W 120th Ave, Suite 600  
Westminster, CO 80234 • 720-287-5182

# Table of Contents

<b>Important Safety Information</b> .....	4
Unpacking and Setup .....	7
Installing the Cutting Cord.....	8
Filling with Gasoline and Oil.....	9
Operation .....	10
Setting the Cutting Height .....	11
Cutting Cords Recommendations.....	12
Trimming Ball.....	13
Cutting Head Assembly.....	14
Operating Environment .....	15
Maintenance.....	17
Troubleshooting .....	21
Handlebar Assembly .....	24
Axle/Wheel Assembly.....	25
Trim Ball Assembly.....	25
Engine Assembly.....	26
Warranty and Specifications .....	Back Cover

# Important Safety Information



WARNING

**WARNING:** Read and thoroughly understand all instructions and safety information before assembling or operating this trimmer/mower. Failure to do so may cause serious injury or death. Do not allow anyone to operate this trimmer/mower who has not read this manual. As with all power equipment, a trimmer/mower can be dangerous if assembled or used improperly. Do not operate this trimmer/mower if you have doubts or questions concerning safe operation.

Call our customer service department at **720-287-5182**, **1-877-487-8275**, or visit [www.dirtyhandtools.com](http://www.dirtyhandtools.com) if you have any questions or concerns about the safe operation of this equipment.



DANGER

## Intended Use

Do Not Use the trimmer/mower for any purpose other than for which it was designed. Any other use is unauthorized and may result in serious injury or death.

## Personal Protective Equipment

When operating this trimmer/mower it is essential that you wear safety gear including goggles or safety glasses, adequate clothing and tight fitting gloves (no loose cuffs or draw strings). Always wear ear plugs or sound deafening headphones to protect against hearing loss when operating this trimmer/mower. Always wear sturdy footwear. Never wear sandals, sneakers or open shoes, and never operate the trimmer/mower with bare feet. Do not wear loose clothing that might get caught in moving parts.



CAUTION

**Whenever you leave the operating position to make adjustments, change cords or if you have to remove grass or debris from the underside of the deck, always shut off the engine and wait five (5) minutes to allow parts to cool.** Remove the key or disconnect the spark plug wire and keep the wire away from the spark plug to prevent accidental starting.

# Important Safety Information

## General Safety

Failure to follow warnings, cautions, assembly and operation instructions in the Operation Manual may result in serious injury or death.



### **READ THE OPERATION MANUAL BEFORE OPERATION.**

- **Do not** permit children to operate this equipment at any time. Do not permit others that have not read and understood the complete Operation Manual to operate this equipment.
- Keep all people and pets a minimum of 10 feet away from the work area when operating this trimmer/mower.
- **Do not** operate the trimmer/mower when under the influence of alcohol, drugs or medication.
- **Do not** allow a person who is tired or otherwise impaired or not completely alert to operate the trimmer/mower.



### **CAREFULLY INSPECT THE AREA TO BE TRIMMED AND REMOVE ALL FOREIGN OBJECTS.**

- Stop the cutting cords when crossing gravel or loose pebbles.
- Never operate your unit on a slippery, wet, or muddy surface.
- Always operate the mower from behind the handlebar. Never pass or stand on the discharge side of the machine when the engine is running or cutting cords are spinning.
- Never, under any conditions, remove, bend, cut, fit, weld, or otherwise alter standard parts on the trimmer/mower.
- If the cutting cords strike a foreign object or if your machine should start making an unusual noise or vibration, stop the engine and wait five (5) minutes for all moving parts to come to a complete stop and cool.
- Be cautious when using your trimmer/mower around fencing, wires, ropes, and hoses.
- Do not operate on slopes greater than 20 degrees.

# Important Safety Information

- Never run the engine in an enclosed area or without proper ventilation as the exhaust from the engine contains carbon monoxide, which is an odorless, tasteless, and deadly poisonous gas.
- Fill the gasoline tank outdoors with the engine off and allow the engine to cool completely.
- Do not operate the engine with the air cleaner or cover over the carburetor air-intake removed, except for adjustment. Removal of such parts could create a fire hazard.
- The muffler and engine become very hot with use and can cause a severe burn; do not touch. Allow the engine to cool before refueling, doing maintenance, or making adjustments.

## Safety Decals

Safety labels on the trimmer/mower are to remind you of important information while you are operating the unit. Make sure all safety warning decals are attached and in readable condition. Replace missing or defaced decals. Contact Dirty Hand Tools at **1-877-487-8275** for replacement decals.



# Unpacking and Setup

Your trimmer/mower is assembled at the factory and shipped with the handlebar folded forwards. Loosen both adjustment knobs (Figure 1) and align the handlebar both sides to a comfortable operating position. Tighten the adjustment knobs securely. It is important to find a handlebar height that allows the trim ball to hover just above the ground and remain balanced so you do not have to push down or pull up on the handlebar.

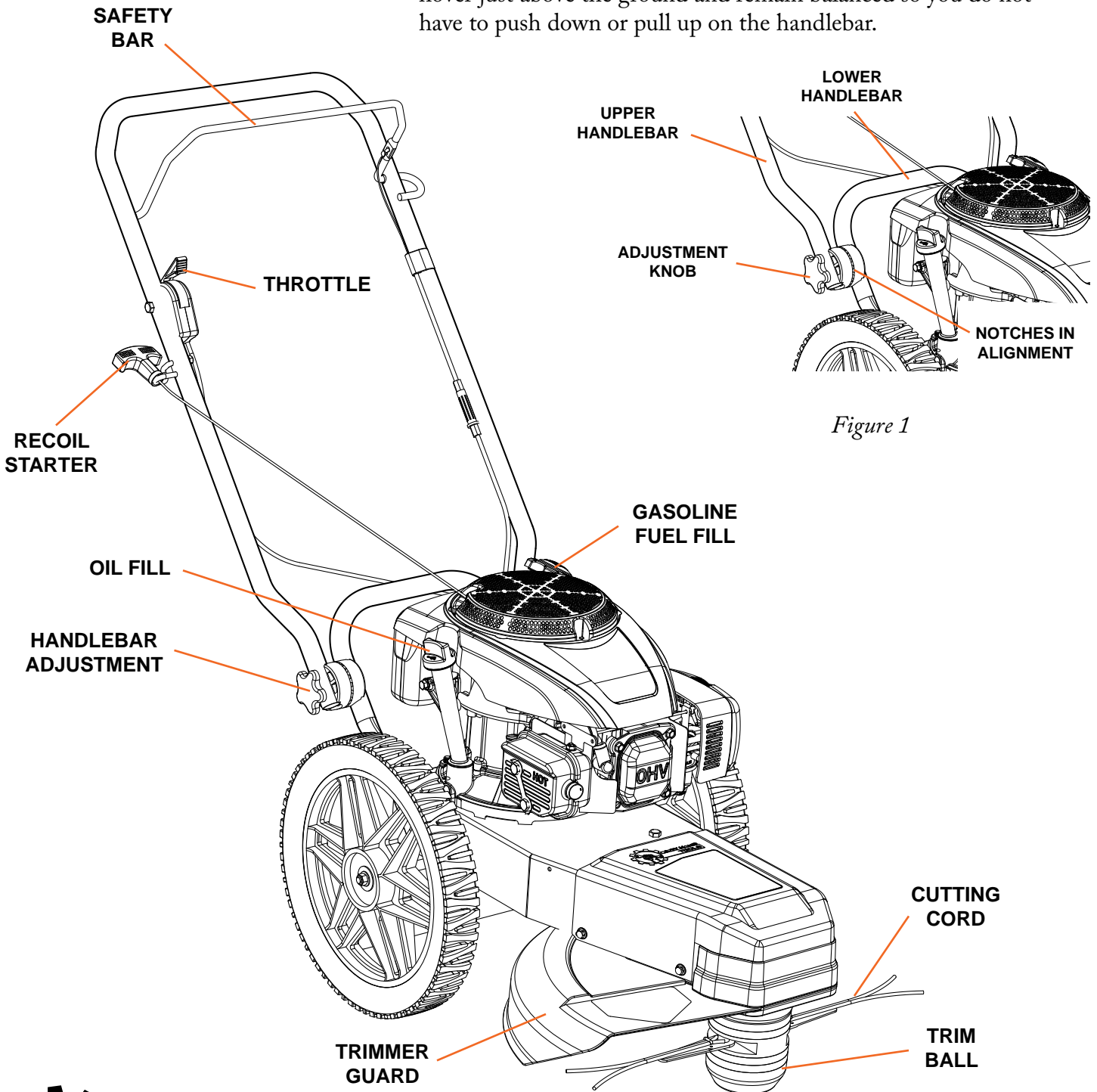

Figure 1

# Installing the Cutting Cord

## Installing the Cutting Cord

There are two installation points on the line plate. Each point is 180 degrees apart. Always install two cords, one opposite the other of the same length and weight (diameter).

1. Insert the end of the cord into the side openings in the line plate (Figure 2).
2. Push the cord through until the end comes out the center hole in the line plate. Adjust the cord ends so the tips are of equal length.
3. Pull the cord under the loop and push the loop up into the line plate groove above them (Figure 3) and then pull the cord ends tight.

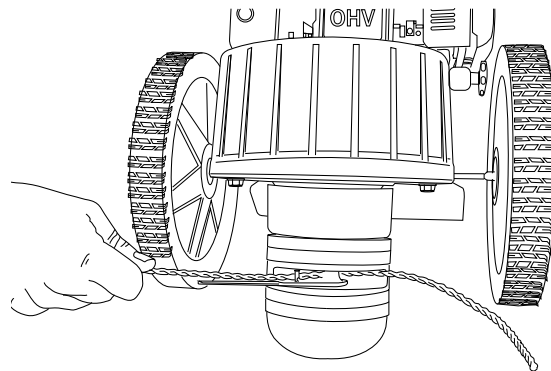

Figure 2



CAUTION

**If the tips of the cutting cords are not of equal length, it can cause unbalance of the trimmer and will result in increased vibration and potential damage to the trimmer.**

Figure 4 illustrates the proper cord installation on the line plate. It shows the line plate from a top view. The cord ends should be of equal length and the same length on each side. There are two installation points on the line plate. Each point is 180 degrees apart. Always install two cords, one opposite the other.

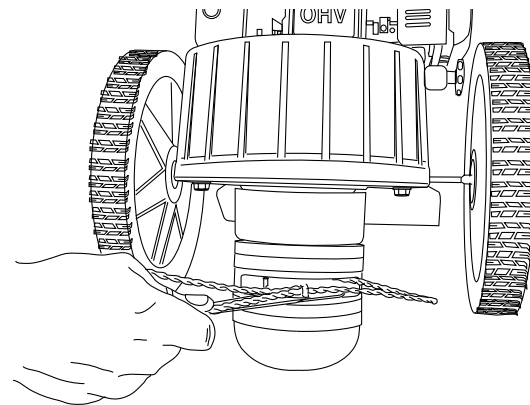

Figure 3

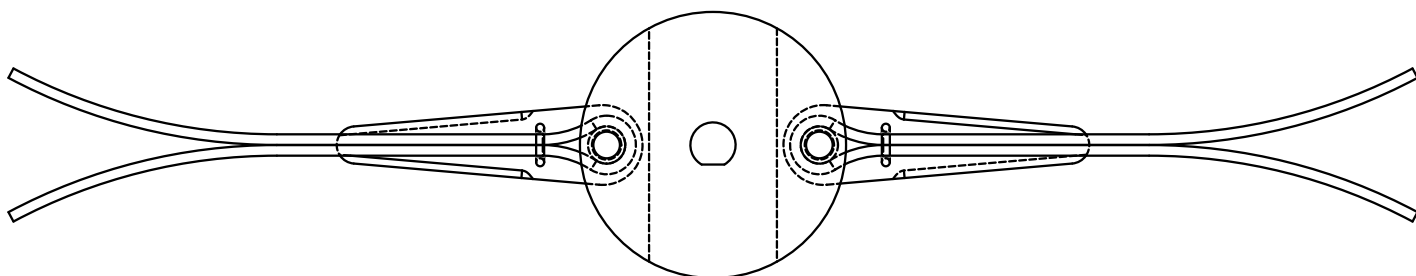

Figure 4



# Filling with Gasoline and Oil



WARNING

**ADD OIL BEFORE STARTING THE ENGINE**  
**The trimmer/mower is shipped without fluids installed.**

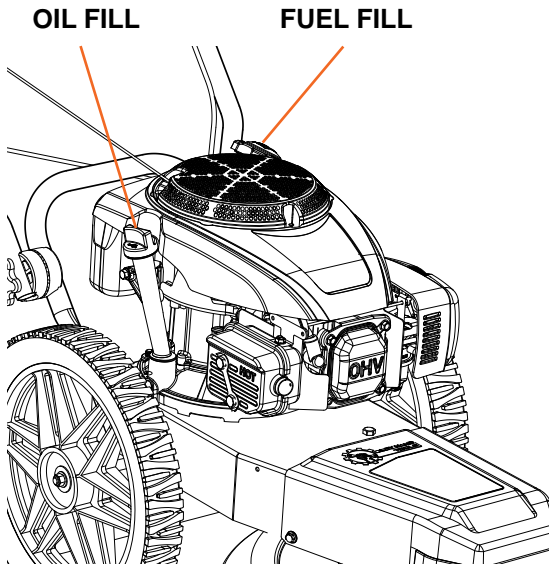

Figure 5

Keep the caps on the fuel and oil fills until you are ready to pour either gasoline or oil into the correct fill.

**Requires approximately 15 - 22 ounces of SAE 30 engine oil.**

Please refer to your Engine Owner's Manual for detailed information on oil quantity and cold temperature oil specifications.

1. Place the machine on a level surface and initially add 1/2 of the SAE 30 high detergent oil into the oil fill (Figure 5) and wait one (1) minute for the oil to settle.
2. Check the dipstick and continue adding a few ounces of oil at a time, rechecking the dipstick until the oil reaches the fill mark. Be careful not to overfill.
3. Fill the fuel tank with fresh, unleaded gas (min. 85 Octane), to 1/4" from the top of the fill neck to allow for expansion. Be careful not to overfill and reinstall the cap before starting the engine.



WARNING

**ALWAYS FILL THE TANK WITH  
ENGINE OFF AND COOL.**

**ALWAYS CHECK THE OIL LEVEL  
BEFORE OPERATING.**

Allow the engine to cool for at least two minutes before removing the fuel cap.

Before performing any adjustments to the trimmer cords or any other procedure or inspection, stop the engine, wait five minutes to allow parts to cool. Disconnect the spark plug wire, keeping it away from the spark plug. Contact with internal rotating parts will cause serious personal injury. Never put hands, face, feet, or clothing under the mower deck or discharge opening at any time.

# Operation



CAUTION

## CHECK THE ENGINE OIL LEVEL

Check fuel level. Remove any debris from around the underside of the trimmer/mower.

### Manual Starting

1. Push the throttle control lever on the right side of the handlebar (Figure 6) all the way forward (choke position).
2. Grasp the recoil starter and slowly pull until you feel resistance. Let the cord retract a little bit and then pull the cord rapidly to start the engine. One or two pulls usually starts the trimmer/mower. *Do not engage the safety bar until after the engine has started.*
3. Once the engine is started, move the throttle lever to the RUN or IDLE position.

If the engine fails to start after several pulls of the recoil starter, allow the motor to cool down. Check the cause of hard starting; see the Troubleshooting Guide (page 21).

### Stopping the Engine

1. Move the throttle control lever (Figure 6) all the way back past the SLOW position to the STOP position.

### Engaging the Trimmer Head

1. Bring the safety bar toward you and grip it together with the handlebar. Cutting cords rotate until you release the safety bar.

Note: Before using your trimmer for the first time or after you have installed a new belt, engage the safety bar 10 times and hold it for 3 seconds each time.

### Stopping the Cords from Spinning

1. Release the safety bar from the handlebar. The trim ball will stop spinning while the engine continues to run.

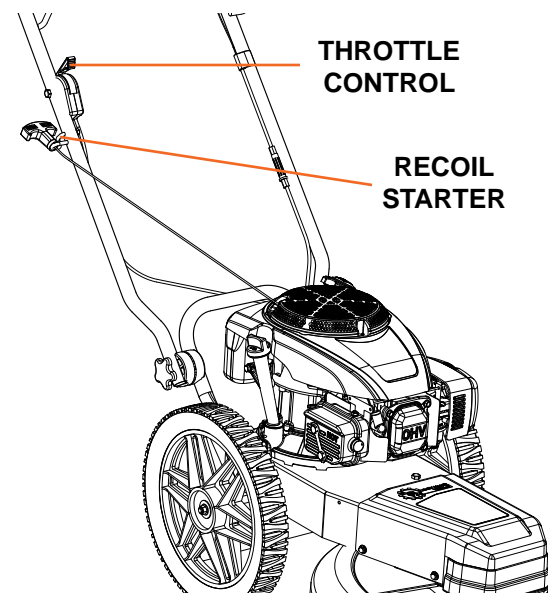

Figure 6

# Setting the Cutting Height

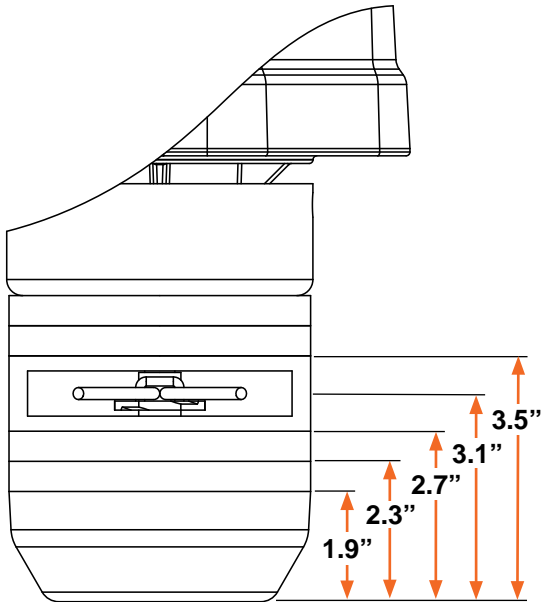

Figure 7



CAUTION

**BEFORE PERFORMING ANY ADJUSTMENT, MAINTENANCE PROCEDURE OR INSPECTION, STOP THE ENGINE, WAIT FIVE (5) MINUTES TO ALLOW PARTS TO COOL AND DISCONNECT THE SPARK PLUG WIRE, KEEPING IT AWAY FROM THE SPARK PLUG.**

Setting the cutting height is easy. Cutting heights range in 10mm (0.3937") increments from 1.9 inches (minimum) when using the line plate in the bottom position, to approximately 3.5 inches when using the line plate in the top position (Figure 7). Install the line plate with the spacers in the position that gives you the desired cutting height.



WARNING

**Running the trimmer with cords of unequal length or a cord installed at other than 180 degrees apart can cause excessive vibration and may damage the machine.**

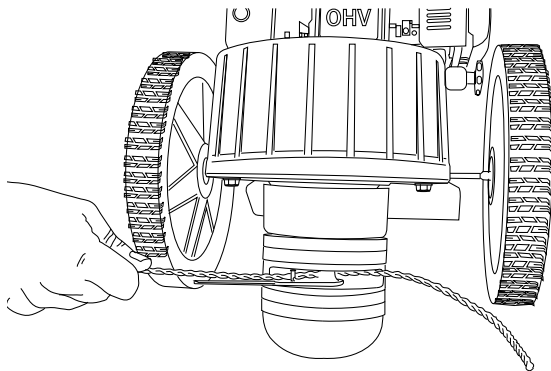

Figure 8

## Installing the cutting cord

After you install cutting cord, and before trimming, engage the trim ball with the engine running to spin the new cord for a few seconds so they pull tight and are set.

1. Insert the ends of the cord into the side opening in the line plate (Figure 8), and pull the cord through.
2. Push the cord through until the ends come out the center opening in the line plate. Adjust the cord ends so they are even.
3. Pull the ends of the cord under the loop and push the loop up into the line cord ends plate groove above them (Figure 9) and then pull the ends tight.

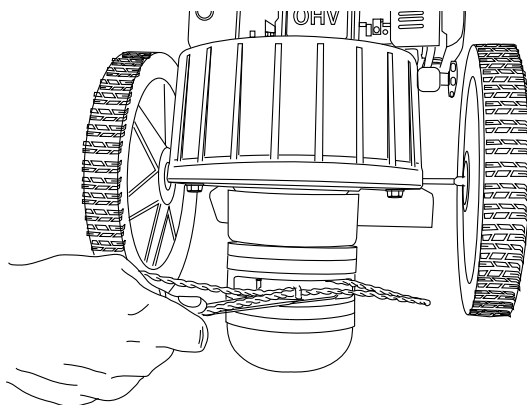

Figure 9



## Cutting Cord Recommendations

Cutting cord is available in Blue (175 mil) and Green (155 mil).

Because conditions and vegetation vary so much, you should experiment with cord weights (diameters) to discover what works best for your particular mowing and trimming situations. Here are a few things to keep in mind:

- If the cutting cord is purchased in rolls, cut to 25” lengths.
- Cord life depends on trimming conditions. Replace cords when they become broken or frayed.
- The smallest diameter cord combined with the fastest engine speed provides the best grass trimming performance. The 175 mil cord is recommended for thicker growth such as berry cane, bramble, thistle, and ragweed.
- Ease the ends of the cord into heavy growth and move slowly through thick growth. If there are woody weeds in the material you are cutting, the cutting cords may wrap around the stalks they cannot cut, and pull away from the trim ball.
- Installing two (2) cords, 180 degrees apart, of equal length on the line plate, is the best method for optimal trimming performance.
- When replacing cords, do it one at a time and use the old cord to mark the position for the new cord that you are replacing.
- If the cord breaks off flush at the line plate, use needle nose pliers to pull out the old cord.
- Storing the cord in a plastic bag with a damp sponge or cloth will help keep it pliable. You can also soak your cutting cord in a bucket of room temperature water for a few days before use to make it more pliable.
- UV light can degrade cord, store out of direct sunlight.

**DO NOT USE DIFFERENT WEIGHT CORDS ON THE TRIM BALL AT THE SAME TIME. THIS CAN CAUSE EXCESSIVE VIBRATION AND MAY DAMAGE THE MACHINE.**

# Trimming Ball

Allow the front end of the machine to rest lightly on the trim ball as you are trimming. The trim ball should glide on the ground as you maneuver the machine. To achieve the best and smoothest cut, do not lift up on the handlebar while operating your trimmer/mower. Lifting the handlebar will force weight down on the trim ball. This uses more energy, slows the cutting, and produces an unsatisfactory cut. Ideally, the trim ball should lightly rest on the ground while the wheels balance most of the weight of the machine.

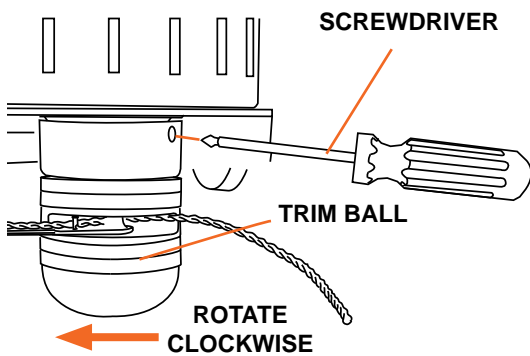

Figure 10

## Replacing the Trim Ball or Line Plate

### CUTTING HEAD DISASSEMBLY

Tools and Supplies Needed:

- Phillips head screwdriver with at least a 6" shank
- Gloves

1. Align the hole in the anti-wrap canister with the hole in the internal housing at the location shown (Figure 10).
2. Insert a phillips head screwdriver into the hole in the anti-wrap canister and the hole in the internal housing.
3. Rotate the trim ball assembly until the screw driver slides into a hole in the shaft, locking it into place.
4. Looking down at the top of the frame, turn the trim ball clockwise until it unscrews completely from the bearing housing.

**NOTE:** If the trim ball continues to turn, but does not come off, check to be sure that you locked the screwdriver into the shaft. If the trim ball will not turn by hand a 9/16" socket wrench can be used on the bolt (inside the bottom of the trim ball) to loosen it. You may need to clean grass or debris out of the recess first.

5. Slide the line plate and spacers off the shaft.

# Trim Ball Assembly



CAUTION

**Improper installation can cause damage to the trimmer bearings. Follow directions carefully to protect the trimmer/mower from damage.** Assemble components in the order shown (see figure 11.)

1. Place the spacer and bearing cover (with the lip facing up) onto the shaft (Figure 11).
2. Align the flats at the center of the plates with the flat on the shaft and slide the line plates onto the shaft. Ensure they are facing top side up as shown.
3. Place the head of the trim ball bolt so it is sitting in the hex cavity at the bottom of the trim ball.
4. Looking down at the top of the frame, hold the bolt head in place with your finger and turn the trim ball counterclockwise to start the bolt into the shaft.
5. Insert the screwdriver as shown in Figure 10 and tighten the assembly securely by turning the trim ball counterclockwise when looking down on the top of the frame.

NOTE: When finished there should be no gaps between any of the components.



WARNING

**Always make sure you remove the screwdriver from the head assembly when finished. Failure to remove the screwdriver could cause injury when the head assembly is engaged.**

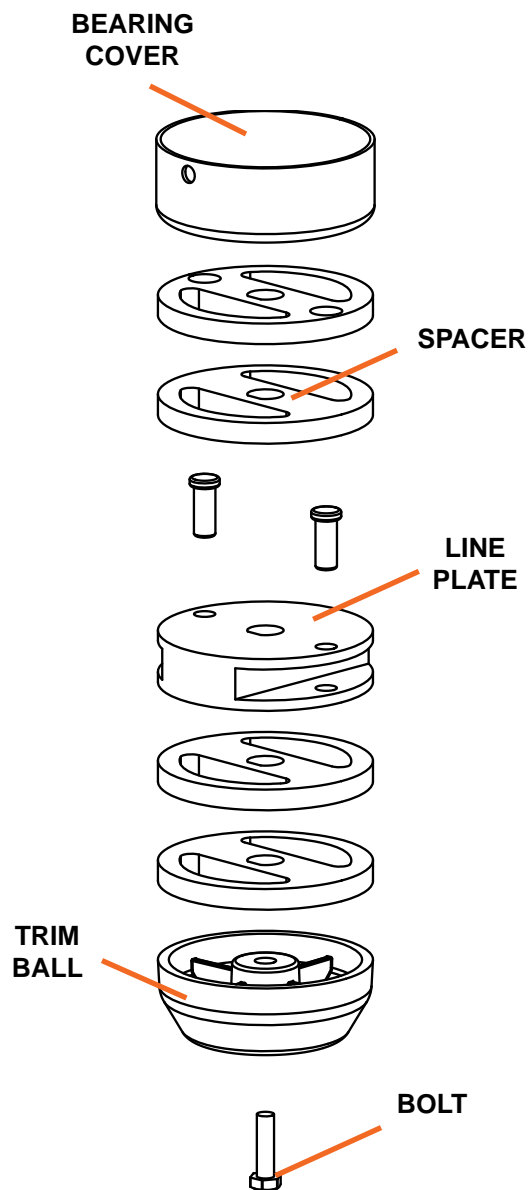

Figure 11

# Operating Environment



WARNING

**The trimmer can easily throw debris at great velocity, which could cause personal injury or property damage. Do not run the machine over loose gravel or mulch with the trim ball spinning.**

The trimmer/mower discharges cut material to the right. Always try to cut and trim with the uncut tall grass or weeds on the left.

- Always check your work area before trimming and remove any debris that might tangle or damage the machine.
- If you do run into debris and the trimmer becomes tangled, turn off the engine and disconnect the spark plug wire before attempting to untangle the machine.
- For the neatest appearance, do your trimming first, discharging clippings away from borders and shrubs, then do your mowing.
- Many owners like to mow easy, open areas with their regular riding or walk behind mower and finish trimming all the odd and hard-to-reach spots with the trimmer/mower.

## Heavy Growth Trimming Recommendations

- Take your time in heavy growth.
- Be sure to keep uncut material to your left, maintaining a clear discharge area to your right.
- If the machine cannot do it all in one pass, overlap half of the cutting swath.
- If the grass is very thick and heavy, try raising the trim ball off the ground a few inches by pushing down on the handlebar. Cut the material at this height, and then make a second pass with the trim ball close to the ground.
- Ease the trimmer/mower into denser growth. If the material is too tough or woody to cut, the cutting cords will wrap around it, wear down, or even break off.
- Sometimes the growth is so heavy, you cannot mow it in rows. Use a forward and back “vacuum cleaner” motion in these cases.

# Operating Environment

## Wet Environments

You can use the trimmer/mower in damp and wet conditions, after a rain, or in the early morning dew without clogging or stalling. You can mow wet areas such as ditches and around ponds.

Note: NEVER mow in the rain. Water on the spark plug may cause the engine to stall.

## Dry Environments

When trimming and mowing in very dry conditions, be extra cautious of cut grass, chaff, weeds, seeds, etc., accumulating on the engine, especially around the recoil-starter housing and engine cooling fins. Please see the Engine Owner's Manual for more detailed information on cleaning the air intake, air filter, and cooling system on the engine.



WARNING

**Frequently remove debris from the recoil guard on top of the engine and the cooling fins on the front of the engine to prevent overheating and engine damage.**

## Slopes

You can trim and mow on slopes up to 20 degrees. Continuous use on slopes steeper than 20 degrees may deprive the engine of adequate lubrication, and damage components.

## Windrows

The trimmer/mower cutting cords cut tall grass in one pass, so you can collect clippings and leaves for mulch without raking. The machine ejects cut material to its right side, so you can use it like a lawn broom to make cleanup easy and to create windrows

## Firebreaks

Use your trimmer as a labor saving tool to cut material when creating firebreaks.

## Garden Clean-Up

The trimmer/mower is perfect for cutting down dead perennials, annuals, and wildflowers, saving you hours of hand pruning and deadheading. You can also re-cut downed material a second time to create mulch for garden beds.



# Maintenance



**BEFORE PERFORMING ANY MAINTENANCE PROCEDURE STOP THE ENGINE, WAIT FIVE (5) MINUTES TO ALLOW ALL PARTS TO COOL.**

**Disconnect the spark plug wire, keeping it away from the spark plug.**

Regular maintenance is the way to ensure the best performance and long life of your machine. Please refer to this manual and the engine manufacturer's owner's manual for maintenance procedures.

## Maintenance Checklist

Maintenance Procedure	Before Each Use	Every 25 Hours of Use	Every 100 Hours of Use
Check engine oil level	X		
Clean engine exterior, cooling fins and remove debris. <i>Cleaning the engine top during use is critical for proper air flow.</i>	X		
Check general equipment condition including nuts, bolts, welds, etc.	X		
Replace broken or frayed cutting cords	X		
Check trim ball and line plate for excessive wear	X		
Check the belt for stretching Adjust the drive cable if necessary	The first time after 2 hours of use	X	
Lubricate throttle cable and trimmer control cable with SAE 30 oil		X	
Change the engine oil	The first time after 5 hours of use	X	
Replace the engine air filter cartridge and foam pre-filter if equipped.		X	
Replace spark plug			X

# Maintenance

## Changing The Engine Oil

Tools and Supplies needed:

- SAE 30 HD Oil (refer to your Engine Owner's Manual for quantity required)
- Suitable container for used oil
- Rags
- Wooden pallet or workbench

NOTE: Drain the oil when the engine is warm. Warm oil drains quickly and completely.

1. For convenience, place the machine up on a wooden pallet or workbench.
2. Remove the oil cap/dipstick and position a suitable oil receptacle beside the oil fill tube.
3. Make sure to securely tighten the gas fill cap.
4. Using the handle of the trimmer/mower, tip the machine to drain the oil out through the oil filler tube into a suitable receptacle. (Figure 12).

NOTE: Be sure to use environmentally safe disposal procedures in the disposing of the used oil.

5. Refill the engine using SAE 30 HD oil to the level indicated on the dipstick.

## Adjusting the Belt Tension through the Trimmer Control Cable

Before adjusting the trim ball belt tension cable, check that the belt is properly installed. Also make sure the cable is attached to the bail bar. The belt will stretch a little when new, then more over time. If the trim ball does not spin with the safety bar engaged, adjust the trimmer control cable to put more tension on it. The adjuster is located on the control cable itself.

1. Locate the trim ball cable along the left handlebar. There is an in-line adjuster to change the tension on the cable (Figure 13).
2. You can take the slack out of the cable by holding the hex flat sections of the in-line adjuster and rotating the body of the in-line adjuster in the counterclockwise direction as you look down on the cable. If the cable is too tight, you can loosen the cable by twisting the adjuster in the opposite direction.
3. If the in-line adjuster cable is adjusted all the way out and more adjustment is needed then the belt needs to be replaced.

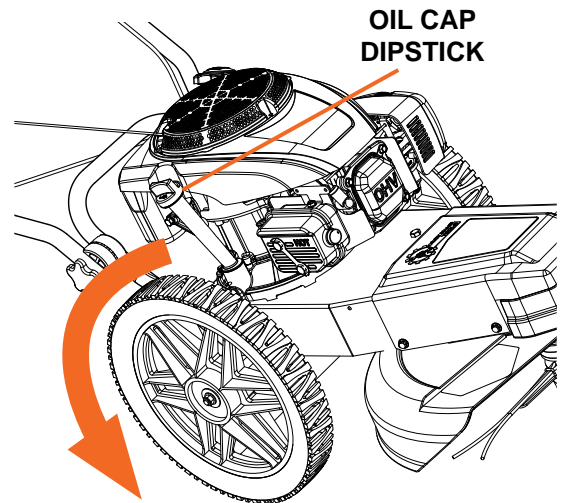

Figure 12

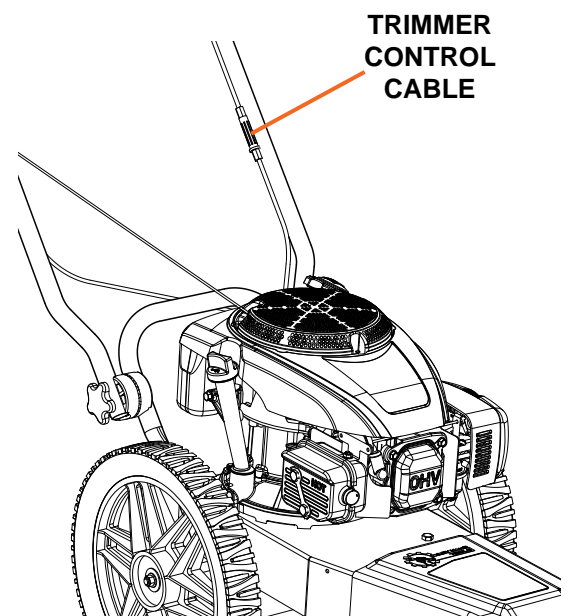

Figure 13

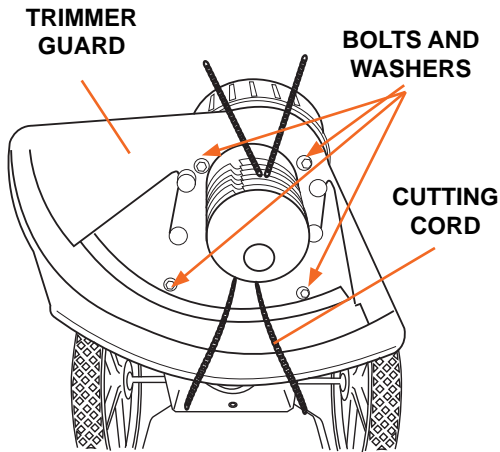

Figure 14

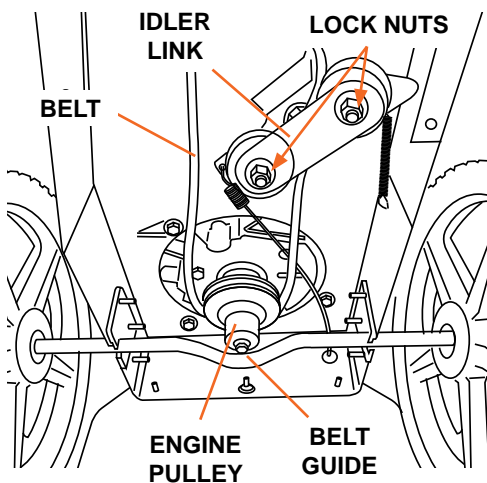

Figure 15

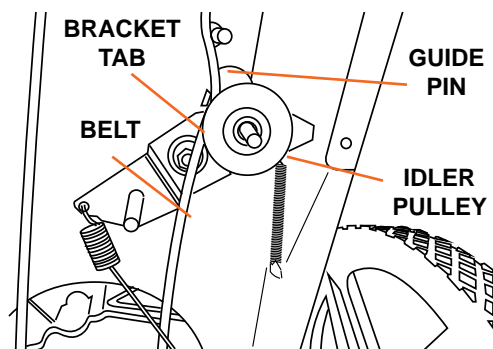

Figure 16

## Replacing the Belt

Tools and Parts needed:

- 10mm Wrench
- 13mm Wrench

1. Tip the machine back just far enough to access the underside and support the handlebars.
2. Unscrew trim ball cap and remove trim ball plates from spindle.
3. Remove the four debris guard bolts and flat washers with a 10mm wrench. Remove the trimmer guard (Figure 14).
4. Loosen the belt guide locknut using a 10mm wrench (Figure 15) and rotate the guide out of the way.
5. Remove the two locknuts from the idler link using a 13mm wrench so the idler link, idler pulleys and spacers can be removed from the machine.
6. Remove the belt from around the engine and head assembly pulleys.
7. Install a new drive belt around the engine and head assembly pulleys.
8. Install the small spacer and flat idler pulley (Figure 16). Make sure you place the belt correctly between the idler pulley, bracket tab, and guide pin.
9. Install the small spacer and v-groove idler pulley. Position the idler link over the idlers and secure with the two locknuts using a 13mm wrench (Figure 15).
10. Rotate the belt guide into position and tighten the locknut with a 10mm wrench.
11. Position the trimmer guard and secure with the four bolts and flat washers using the 10mm wrench.
12. Install the trimmer cord and tip the trimmer down on the head assembly.
13. After installing the new belt, be sure to adjust the tension properly by adjusting the in-line adjuster all the way in (refer to page 15). Proper tension will extend the life of the belt.

Note: Before using your trimmer/mower for the first time or after you have installed a new belt, engage the safety bar 10 times and hold it for 3 seconds each time. This is required to wear in the belt to ensure the best grip for trimming.

# Maintenance

## Replacing the Wheels

Tool needed:

- 13mm Wrench

1. Block and stabilize the trimmer/mower so that the wheels are off the ground.
2. Loosen and remove the locknut (Figure 17).
3. Slide the wheel off the axle.
4. Reverse the steps to install the new wheel.

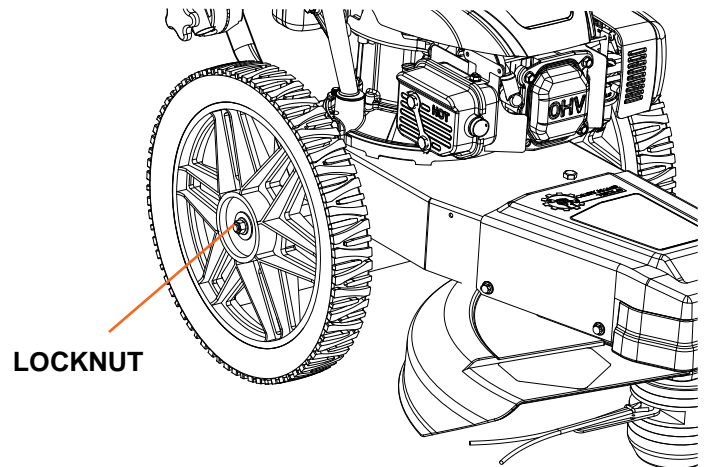

*Figure 17*

# Troubleshooting



WARNING

**BEFORE PERFORMING ANY MAINTENANCE  
PROCEDURE STOP THE ENGINE, WAIT FIVE (5)  
MINUTES TO ALLOW ALL PARTS TO COOL.**

**Disconnect the spark plug wire,  
keeping it away from the spark plug.**

PROBLEM	SOLUTION
<p><b>Recoil will not pull out or is difficult to pull.</b> <i>(Refer to the engine Owner's Manual)</i></p>	<ul style="list-style-type: none"> <li>• Check the engine oil level, the engine may be seized.</li> <li>• There may be an oil compression lock in the cylinder. Take out the spark plug; hold a rag over the spark plug hole and pull the recoil cord several times to blow out any oil in the cylinder. Wipe off the spark plug and reinstall it.</li> <li>• The recoil may be broken or jammed. Try to turn the engine pulley by hand, with the spark plug wire off. If it turns, the recoil is broken or jammed. Visit our web site at <a href="http://www.dirtyhandtools.com">www.dirtyhandtools.com</a> or call 1-877-487-8275 for assistance.</li> </ul>
<p><b>The engine will not start manually.</b></p>	<ul style="list-style-type: none"> <li>• Check that the throttle is in the most forward position (or RUN position when the engine is warm). Check the throttle cable and make sure that it is attached to the engine and is moving freely.</li> <li>• Check for proper attachment of the spark plug wire.</li> <li>• Check that the engine has the right amount of clean oil. If the oil is dirty, change it following the procedure on page 18.</li> <li>• Use only fresh, clean, unleaded gas. If the gas is old, change it. Use a fuel stabilizer if you keep gas longer than one month.</li> <li>• Check the fuel filter (if equipped) to see if it is clear. Place a can under the fuel filter and remove the fuel line from the engine side of the filter. If gas flows freely, it is OK.</li> <li>• Check that the air filter is clean. If it is dirty, change it following the procedure in the engine Owner's Manual.</li> <li>• Make sure that the spark plug is clean. If the spark plug is dirty or cracked, change it. If it is oily, leave it out, hold a rag over the spark plug hole and pull the recoil cord several times to blow out any oil in the cylinder, then wipe off the spark plug and reinsert it.</li> <li>• If the engine still will not start, visit our web site at <a href="http://www.dirtyhandtools.com">www.dirtyhandtools.com</a> or call 1-877-487-8275 for assistance.</li> </ul>

# Troubleshooting

PROBLEM	SOLUTION
<p><b>Engine smokes.</b></p>	<ul style="list-style-type: none"> <li>• Check the oil level and adjust as needed.</li> <li>• You may be operating the machine on too great an incline.</li> <li>• Check the air filter and clean or replace if needed.</li> <li>• You may be using the wrong oil - too light for the temperature. Refer to your engine Owner's Manual for detailed information.</li> <li>• Clean the engine cooling fins and the carburetor housing if they are dirty.</li> <li>• If the engine still smokes, visit our web site at <a href="http://www.dirtyhandtools.com">www.dirtyhandtools.com</a> or call 1-877-487-8275 for assistance.</li> </ul>
<p><b>Engine lacks power or isn't running smooth.</b></p>	<ul style="list-style-type: none"> <li>• Check the throttle travel. The throttle lever should be in the most forward position (or RUN position when the engine is warm).</li> <li>• Check for debris (hay seed, etc.) clogging the air filter intake and clean out as required.</li> <li>• The engine's blower housing, throttle linkage, and cooling fins should be free of debris. Clean them following the instructions in the engine Owner's Manual.</li> <li>• Check that the air filter is clean. If it is dirty, change it following the procedure in the engine Owner's Manual.</li> <li>• Remove the spark plug wire and dry the connection with a rag.</li> <li>• The spark plug may be dirty or cracked, change it. If it's oily, leave it out, hold a rag over the spark plug hole and pull the recoil cord several times to blow out any oil in the cylinder, then wipe off the spark plug and reinsert it.</li> <li>• You should be using fresh, clean, unleaded gas. If it is old, change it. Use a fuel stabilizer if you keep gas longer than one month.</li> <li>• Check that the engine has the right amount of clean oil. If it is dirty, change it following the procedure on page 18.</li> <li>• If your engine still lacks power, visit our web site at <a href="http://www.dirtyhandtools.com">www.dirtyhandtools.com</a> or call 1-877-487-8275 for assistance.</li> </ul>
<p><b>Trim ball won't spin or lacks power.</b></p>	<ul style="list-style-type: none"> <li>• Check for proper alignment of the v-belt. Check it against Figure 20 in the "Replacing the Belt" section on page 19.</li> <li>• The belt may be worn or frayed; if so, replace it.</li> <li>• If the trim ball still will not spin, follow the procedure for "Adjusting the Belt Tension through the Trimmer Control Cable" on page 18.</li> <li>• If none of the above helps, visit our web site at <a href="http://www.dirtyhandtools.com">www.dirtyhandtools.com</a> or call 1-877-487-8275 for assistance.</li> </ul>

# Troubleshooting

PROBLEM	SOLUTION
<p><b>Trim ball keeps spinning or spins when you release the safety bar.</b></p>	<ul style="list-style-type: none"> <li>• Check for proper alignment of the v-belt. Check it against Figure 20 in the “Replacing the Belt” section on page 19.</li> <li>• If the trimmer head keeps spinning when you release the safety bar, see “Adjusting the Belt Tension through the Trimmer Control Cable” on page 18.</li> <li>• If none of the above helps, visit our web site at <a href="http://www.dirtyhandtools.com">www.dirtyhandtools.com</a> or call 1-877-487-8275 for assistance.</li> </ul>
<p><b>Cutting cords are breaking.</b></p>	<ul style="list-style-type: none"> <li>• The cords may be too dry. Store cords in a plastic bag with a damp sponge or cloth to make them less prone to breaking or soak them in a bucket of water for a few days.</li> <li>• You may be trying to do too much too fast. Ease into the material you are cutting; let the cord tips do the work. Take small bites of tall or tough vegetation. Cut half a swath at a time, keeping the cut area to the discharge or right side of the trimmer. Go over tall material twice, the first time with the trim ball tilted up and back; the second time with the trim ball on the ground.</li> <li>• Make sure that you are not hitting the cords against a stone or a chain-link fence. The cords won't last as long against obstacles as in the open. Work on controlling the cutting pattern. With practice, you'll learn to cut closer to obstacles without hitting them.</li> </ul>
<p><b>Cutting Cords are pulling out.</b></p>	<ul style="list-style-type: none"> <li>• You may be moving too fast into tough, woody growth. In doing so, the cords may wrap on stalks and pull out. Check the operating tips in the section above on breaking cords.</li> <li>• Make sure that you are not trying to cut material too heavy for the cord. The design of your trimmer is to cut green material up to about the thickness of a pencil.</li> <li>• If none of the above helps, visit our web site at <a href="http://www.dirtyhandtools.com">www.dirtyhandtools.com</a> or call 1-877-487-8275 for assistance.</li> </ul>
<p><b>The trim ball is wearing too quickly.</b></p>	<ul style="list-style-type: none"> <li>• You may be pushing the trimmer head down into the ground. The trimmer/mower works best with a light touch, with the trim ball resting easily on the ground.</li> <li>• You may be hitting the trim ball against rocks, concrete driveways or other hard obstacles. Try approaching them slowly, and from different directions, to avoid unnecessary wear.</li> <li>• If none of the above helps, visit our web site at <a href="http://www.dirtyhandtools.com">www.dirtyhandtools.com</a> or call 1-877-487-8275 for assistance.</li> </ul>

# Handlebar Assembly

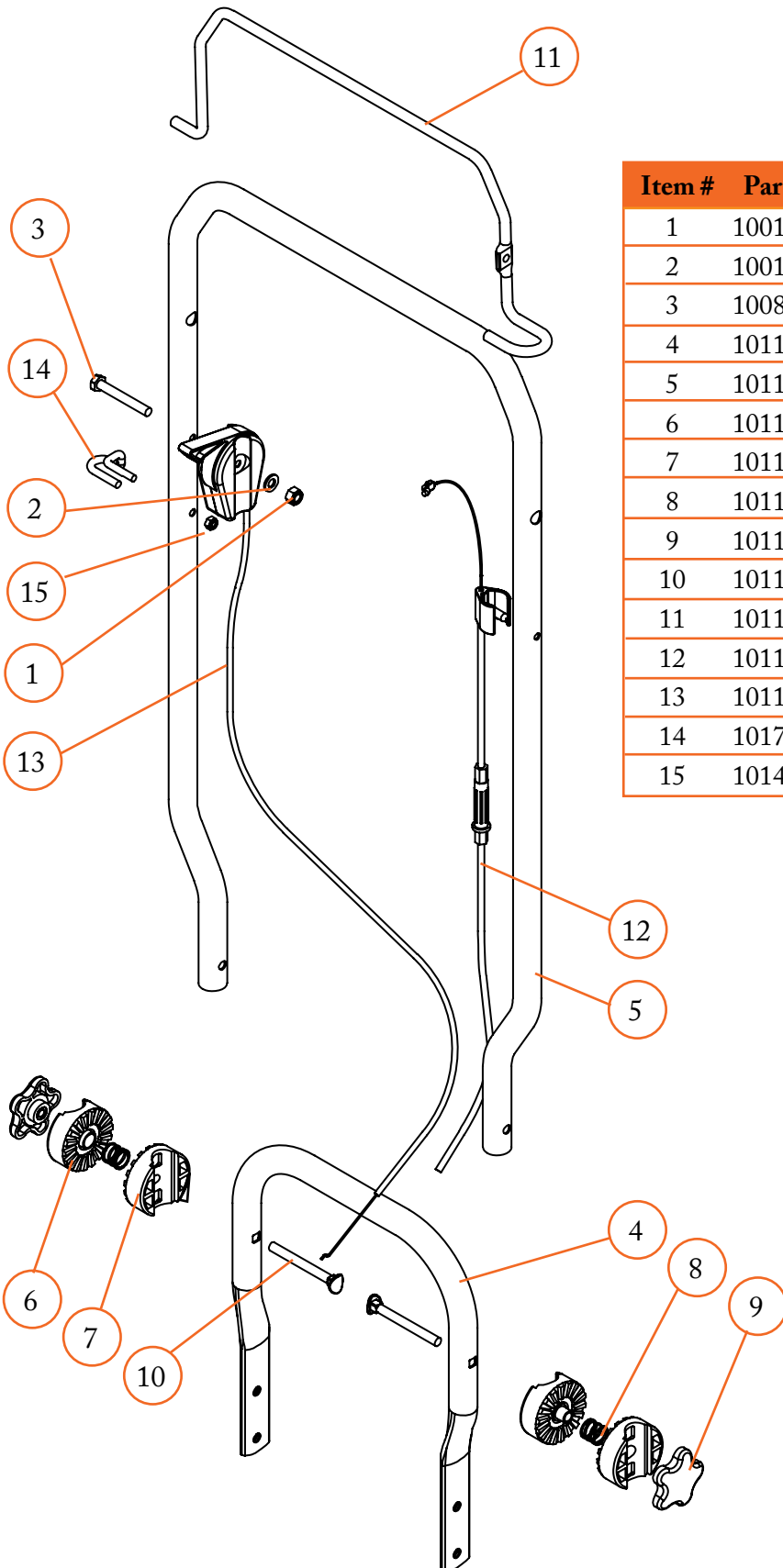

Item #	Part #	Description	Qty.
1	100128	Hex Nut, Nylock, M8 x 1.25, G8.8	1
2	100130	Flat Washer, M8	1
3	100837	Hex Bolt, M8 x 1.25 x 60mm, G8.8	1
4	101156	Lower Handlebar	1
5	101157	Upper Handlebar	1
6	101158	Handlebar Jaw Adjuster, Left	2
7	101159	Handlebar Jaw Adjuster, Right	2
8	101160	Spring .720 OD x .063	2
9	101161	Handlebar Adjuster Handle	2
10	101162	Carriage Bolt, M8 x 1.25 x 80mm	2
11	101165	Bail Bar	1
12	101166	Belt Engagement Cable Assembly	1
13	101164	Throttle Cable Assembly	1
14	101752	Pull Cord Guide	1
15	101494	Hex Nut, Nylock M6 x 1.0, G8.8	1



# Axle/Wheel Assembly

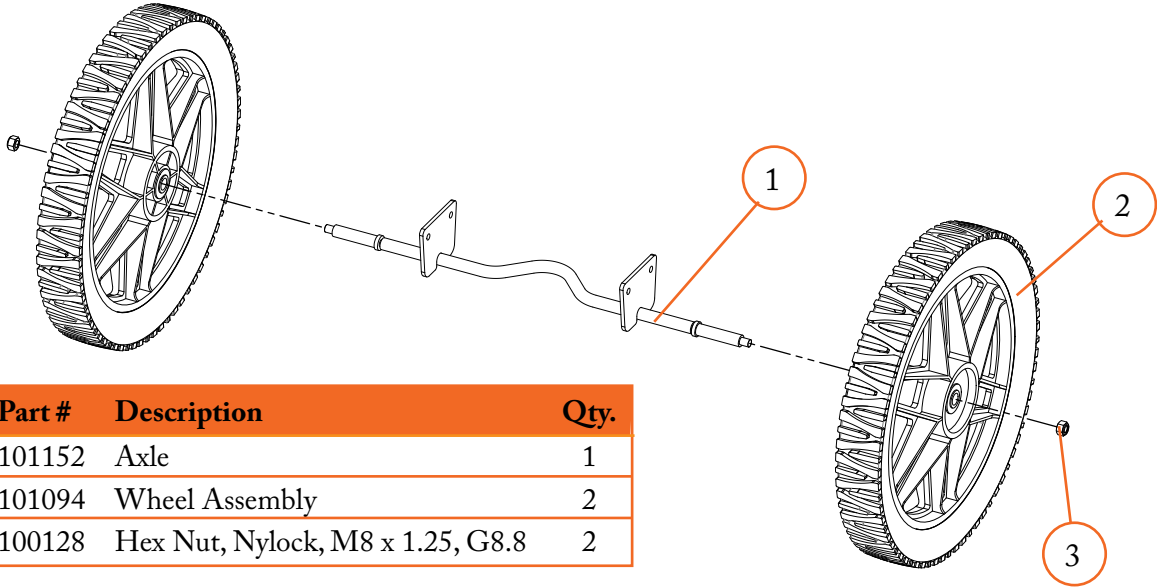

Item #	Part #	Description	Qty.
1	101152	Axle	1
2	101094	Wheel Assembly	2
3	100128	Hex Nut, Nylock, M8 x 1.25, G8.8	2

# Trim Ball Assembly

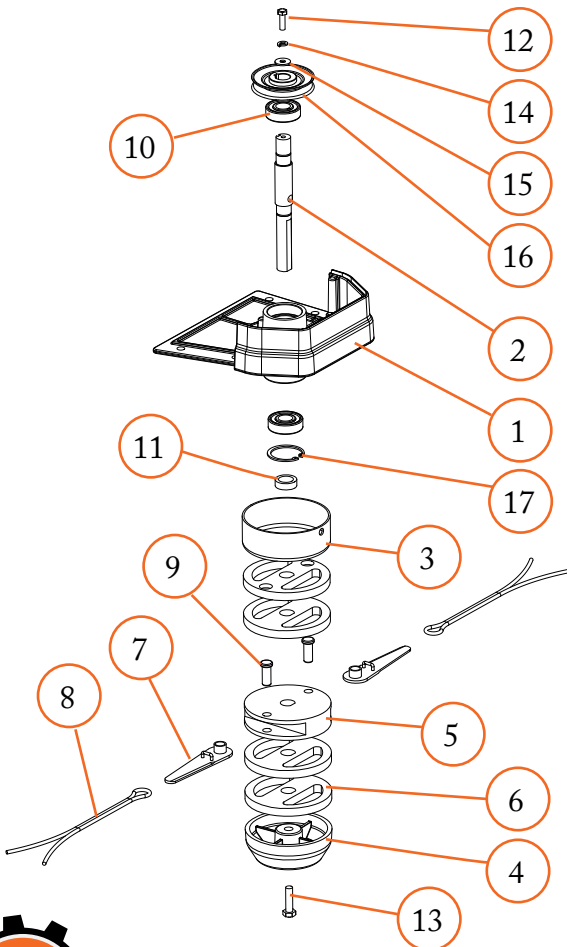

Item #	Part #	Description	Qty.
1	101149	Hexagon Spindle	1
2	101041	Spindle Rod	1
3	101043	Bearing Cover	1
4	101042	End Cap	1
5	101037	Blade Slot	1
6	101038	Spacer	4
7	101036	Blade	2
8	101044	String	2
9	101039	Blade Pin	2
10	101045	Bearing	2
11	101040	Spindle Spacer	1
12	100085	Hex Bolt, M6 x 1.0 x 20mm, G8.8	1
13	100126	Hex Bolt, M8 x 1.25 x 30mm, G8.8	1
14	100202	Lock Washer, M6	1
15	100445	Fender Washer, M6	1
16	101141	Belt Pulley	1
17	101827	Retaining Ring, Internal, 40mm	1

# Engine Assembly

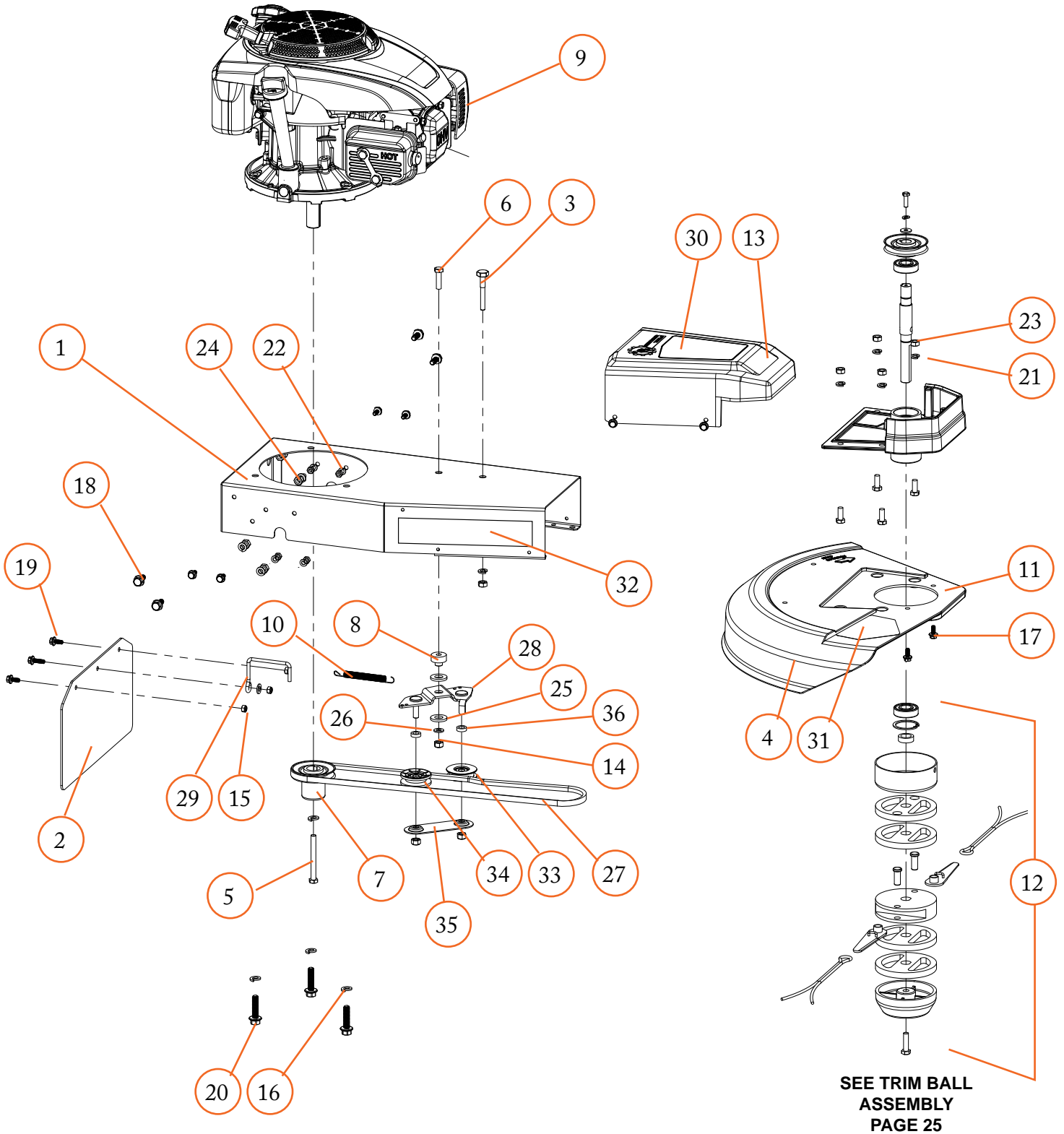

# Engine Assembly

Item #	Part #	Description	Qty.
1	101138	Frame Plate	1
2	101151	Debris Guard	1
3	101148	Belt Guide	1
4	100125	Hex Bolt, M8 x 1.25 x 20mm, G8.8	4
5	101300	Hex Bolt, 5/16-18 x 3", G5	1
6	100126	Hex Bolt, M8 x 1.25 x 30mm, G8.8	1
7	101140	Engine Belt Pulley	1
8	101146	Idler Stand Off	1
9	101136	Engine, Kohler XT6.5, 49ST	1
10	101145	Spring	1
11	101745	String Guard Assembly	1
12	101050	Trim Ball Spindle	1
13	101049	Nose Cover	1
14	100128	Hex Nut, Nylock, M8 x 1.25, G8.8	1
15	101494	Hex Nut, Nylock, M6 x 1.0, G8.8	3
16	101491	Hex Bolt, 3/8-16 x 1.5, G5	3
17	101492	Hex Bolt, M6 x 1.0 x 14, G8.8 1	4
18	101493	Hex Bolt, M8 x 1.25 x 20, G8.8	4
19	101536	Hex Bolt, M6 x 1.0 x 20, G8.8	1
20	100611	Lock Washer, 3/8	4
21	100127	Lock Washer, M8	9
22	100202	Lock Washer, M6	4
23	100579	Hex Nut, M8 x 1.25	9
24	100198	Hex Nut, M6 x 1.0, G8.8	4
25	100077	Flat Washer, 1/2"	2
26	100130	Flat Washer, M8	2
27	101139	V-Belt, 3L X 44"	1
28	101137	Tension Pulley Bracket	1
29	101227	Engine Belt Guide	1
30	101225	DHT Decal	1
31	101052	Danger Decal	1
32	101054	Safety Decal	1
33	101144	Idler Pulley Flat	1
34	101143	Idler Pulley V	1
35	101810	Pulley Bottom Bracket	1
36	101147	Spacer, Idler Pulley	2

# Warranty & Specifications

## IMPORTANT NOTICE

We, the manufacturer, reserve the right to change the product and/or specifications in this manual without notification. The manual is for information usage only and the pictures and drawings depicted herein are for reference only.

## Warranty Repair and Service

Do not return this product to the store for warranty issues or repair. Call our customer service department at **720-287-5182, 1-877-487-8275**, or visit [www.dirtyhandtools.com](http://www.dirtyhandtools.com) for the location of the nearest service center.

**Record the information below for future reference.**

**Model No.** \_\_\_\_\_

**Serial No.** \_\_\_\_\_

**Date of Purchase** \_\_\_\_\_

**Place of Purchase** \_\_\_\_\_

## Specifications

SKU/Part No.	101085
Description	Walk Behind High Wheel String Trimmer
Engine	Kohler XT6.75, 4.2 HP, 149CC*
Engine Speed	3600 RPM
Cutting Width	22 inches
Cutting Height	5 Heights 1.5 - 3.5"
Cutting Speed	3800 RPM
Cutting Line Size	Orange .157" dia. (4mm) x 19" length
Wheel Size	14" x 1.75" width
Frame	14 Gauge Steel
Trimmer Ball	4" dia., with 4" heat treated cutting blade
Drive Belt	V-Belt, 3L440
Dimensions	50.4" L x 21.5" W x 38.3" H
Shipping Weight	67 Lbs.
Accessories	Tree guard, replacement blades, replacement string
Warranty	2 Year / 2 Year Limited Warranty

\*As rated by engine manufacturer

Dirty Hand Tools® is a brand of  
 **FrictionlessWorld**  
1100 W 120th Ave., Suite 600  
Westminster, CO 80234 • 720-287-5182

For Service or Questions  
**Call 1-877-487-8275**  
**720-287-5182**  
[www.dirtyhandtools.com](http://www.dirtyhandtools.com)