

grilling perfection **Aussie** inspired design

LP Gas Grill Assembly and Use Manual

Six Burner Event Grill

Sets Up In Minutes
Great for Every Occasion

700
710

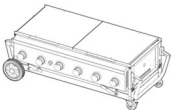

For Outdoor Household Use Only. Not for Commercial Use.

Need Help? Call Customer Service at 1-866-475-5180

⚠️ WARNING

- Failure to follow these instructions could result in fire or explosion which could cause death, serious personal injury, or property damage.
- Read and follow instructions carefully before assembly or use.
- Do not use this product for any other purpose than which it is intended.
- These instructions must be kept with the user. **SAVE THESE INSTRUCTIONS.**

⚠️ WARNING

- Do not store or use gasoline or other flammable vapors and liquids in the vicinity of this or any other appliance.
- An LP cylinder not connected for use shall not be stored in the vicinity of this or any other appliance.

⚠️ DANGER

If you smell gas:

1. Shut off gas to the appliance.
2. Extinguish any open flame.
3. Open lid.
4. If odor continues, keep away from the appliance and immediately call your gas supplier or your fire department.



DANGER

CARBON MONOXIDE HAZARD



This appliance can produce carbon monoxide which has no odor. Using it in an enclosed space can kill you. Never use this appliance in an enclosed space, such as a camper, tent, car, or home.

WARNING

To reduce the risk of serious injury or death from fire or explosion:

- Never leave grill unattended
- Never use alcohol, prescription or non-prescription drugs while assembling or safely operating this appliance.
- Keep children and pets away at all times.
- Do not connect to the LP Gas Cylinder until assembly is complete except as noted for "First Time Use" leak test as detailed on pages 12-13.
- Do not store or use gasoline or other flammable vapors and liquids in the vicinity of this or any other appliance.
- An LP cylinder not connected for use shall not be stored in the vicinity of this or any other appliance.
- Always have a type BC or ABC fire extinguisher readily available.

CAUTION

To reduce the risk of a laceration hazard, wear protective gloves when handling parts that have sharp edges.
To reduce the risk of bodily injury from lifting, assembly will require two people.

NOTICE

**Outdoor Leisure Products strives to be a quality supplier of consumer products.
If we omitted any parts needed for assembly, or you need troubleshooting
information, please contact us using our toll free number.
It is important to retain your receipt.**

1-866-475-5180
8:30am-4:30pm
Central Time
Monday-Friday

Consumer Service Department
Outdoor Leisure Products, Inc.
5400 Doniphan Drive
Neosho, MO 64850

Tools Required for Assembly:



Phillips Screwdriver



Pliers OR Wrench

Packing List

Description

Grill Body	_____
Folding Cart	_____
Firebox Handles	_____
Wheels	_____
Casters	_____
Cylinder Bracket	_____
Cooking Grids (not pictured)	_____
Flavor Activators (not pictured)	_____
Grease Pan (not pictured)	_____
Hardware Pack (not pictured)	_____
Owner's Manual and Warranty Card (not pictured)	_____

Detailed Parts List and Illustrations may be found on pages 26 & 27.

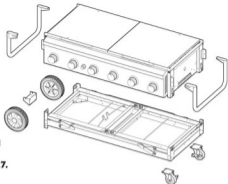

Contents

Packing List	3
Preparation for Assembly	3
Assembly Instructions	
Step 1 Attaching Wheels and Casters	4
Step 1 Attaching Cylinder Bracket	4
Step 1 Attaching Firebox Handles	4
Set-Up Instructions	
Step 1 Unfolding Cart	5
Step 2 Unfolding Firebox Handles	5
Step 3 Placing the Grill Body on the Cart.....	6
Step 4 Opening the Firebox.....	7
Step 5 Flavor Activator/Cooking Grid Assembly.....	7
Step 6 Grease Pan/Foil Pan Installation	8
Step 7 Igniter Battery Installation.....	8
Folding/Preparation for Transport	8
Important Reminders	8
Connecting/Disconnecting the Gas	
Using Gas	9
LP Gas Cylinder.....	9
LP Hose & Regulator.....	10
Connecting LP Gas Cylinder.....	10
Disconnecting LP Gas Cylinder	10

Before Using Your LP Gas Grill

Installation Codes.....	11
Selecting a Location	11
Performing a Leak Test	11
How to Perform a Leak Test.....	12
Lighting Grill Using the Pulse-Spark Ignitor	14
Manually Lighting the Grill	16
Check the Flame	16

Cooking on the Gas Grill

Grill Cooking (Direct Method).....	17
End of Cooking Session	18

Care and Maintenance

Cleaning the Grill.....	19
How to Clean the Burners	20
Bottom Body Panel Removal	21
Storage and Transportation	22

Emergencies

Troubleshooting	23
------------------------------	----

Important Notice- LP Cylinder with OPD

Replacement Parts	
Parts Illustrations	26
Parts List	27

Limited Warranty.....

Retain your receipt.

Preparation for Assembly

Remove Grill Body, the Folding Cart and all the packaging from the carton and place on floor. Make sure there are no loose parts. The Cooking Grids, Flavor Activators, Firebox handles, Grease Pan, Hardware Pack, Wheels and Casters are wrapped and boxed inside the Grill Body, under the Cooking Grids. Open the grill as described on page 7 and remove the cooking grids to access the parts. Unpack and inspect these parts as well.

NOTE: Before using your grill, read the instructions and your manual.

For easier set-up, follow instructions of each step in the order they are written as you look at the diagrams.

If you have any questions or need help, contact **Customer Service at 1-866-475-5180.**

Be sure to have the grill model number and serial number printed on the black label located on the back face of the bottom tube of the cart base. If you need replacement parts, look in the Parts List Section to find the exact parts you need. **If you need a replacement part under warranty, a proof of purchase will be necessary.** You will be asked to forward your proof of purchase and reference your model and serial number. **It is important to retain your receipt.**

CAUTION

PINCH HAZARD

To reduce the risk of bodily injury from pinch hazard, keep hands and fingers away from hinges, leg pivot points and moving parts. Only open the cart by gripping the top of each leg frame. Read and follow these instructions to set up your grill.

Step 1 Attaching the Wheels and Casters

A. Place the cart upside down on a clean flat surface. Insert an Axle through a Wheel and both walls of the corner channel. Fasten in place by inserting an Axle Pin through the small hole near the end of the Axle. Snap the Hubcap on to the Wheel. Repeat for other Wheel.

B. Attach the casters to the bottom of the cart as shown with 4) 1/4-20 x .5" Bolts each caster.

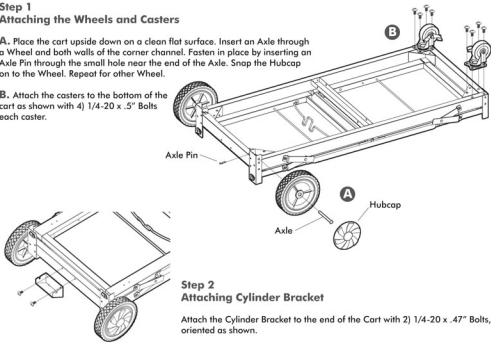

Step 2 Attaching Cylinder Bracket

Attach the Cylinder Bracket to the end of the Cart with 2) 1/4-20 x .47" Bolts, oriented as shown.

Step 3 Attaching the Firebox Handles

Place the Handle between the brackets on the end of the firebox and align the slot with the hole. For each side of the Handle, insert a 1/4-20 Shoulder Bolt from the inside so that the shoulder is through the slot in the handle and tight against the firebox bracket. Fasten in place on the outside with a 1/4-20 Locking Nut. Repeat for other Handle.

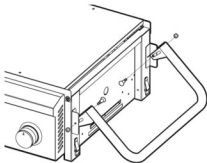

Set-Up Instructions

Step 1 Unfolding Cart

To avoid being pinched by hinges or moving parts, only open the cart by gripping the top of each leg frame.

Gripping at the top, lift up and outwards until the leg frames are straight up. Press down firmly at the center of each Leg Lock Bracket to insure each is straight and in the locked position.

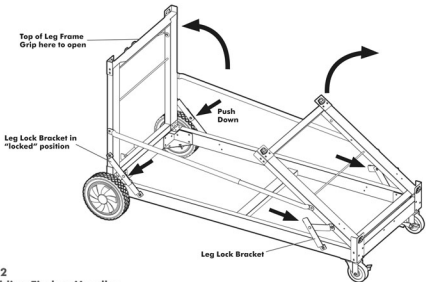

Step 2 Unfolding Firebox Handles

A. Grasp the "Gripping Portion" of the Firebox Handle and rotate upwards until it is straight out from the firebox.

B. With the handle straight out, push straight down on both sides of the bracket parts of the handle nearest the firebox. This seats the handle in place for lifting the firebox.

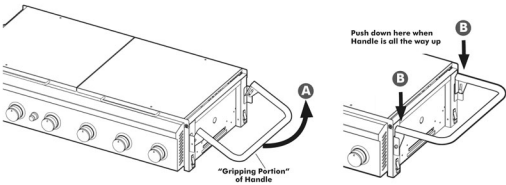

⚠ CAUTION

To reduce the risk of bodily injury from lifting, the following assembly step will require two people.

Step 3 Placing the Grill Body on the Cart

With one person at each end, grasp the "Gripping Portion" of the Tubular Handles and place the Grill Body on Cart. Corners of Firebox will fit INSIDE brackets on top of legs.

IMPORTANT: Be sure to engage latches at all four corners before moving grill.

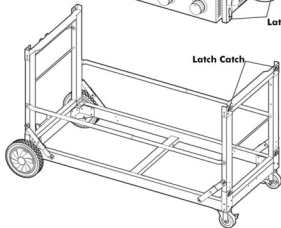
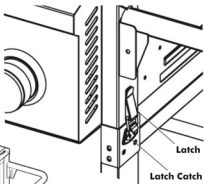
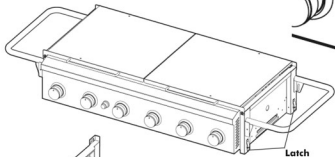

⚠ WARNING

To reduce the risk of serious bodily injury or death from fire or explosion:
Never remove guards or devices to prevent storage of spare or oversize LP Gas Cylinders not recommended for this grill.

Step 4 Opening the Firebox

IMPORTANT: Be sure the Firebox Handles are in the Up and Locked position before opening and using side tables.

A. First, open the left side table, then open the right. When closing, first close the right side table so the drainage lip is under the edge of the left side table.

B. Next, lift up the windscreen at the back until it is straight up.

C. Fold out the side windscreens and snap the tabs at the front into notches in the firebox. Push gently at the top front edge of the side windscreen to help lock in position. The lip on the outside bottom of the side windscreen should rest on top of the side of the firebox.

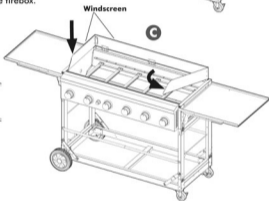
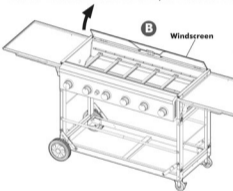
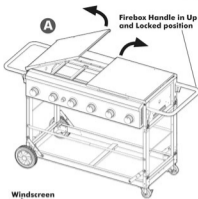

Step 5 Flavor Activator / Cooking Grid Assembly

A. Place a Flavor Activator over each burner. The bottom edges of the Flavor Activators will rest in notches in the ledges inside the firebox.

B. Place the Cooking Grids over the Flavor Activators on the upper Body ridges.

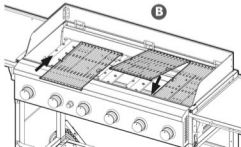
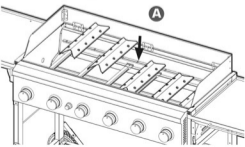

Step 6 Grease Pan / Foil Pan Installation

Insert the Foil Pan into the Grease Pan. Slide the Grease Pan into the guides under the Bottom Body Panel. This can be done from the front of the grill as well.

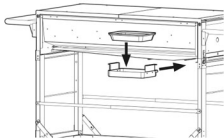

Step 7 Igniter Battery Installation

Unscrew Igniter Cover and insert AA Battery with the negative "-" end going in first. Replace the cover and tighten securely.

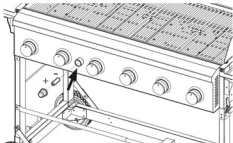

Folding/Preparation for Transport

Folding steps are essentially the reverse of Set-Up.

1. Wait until the grill is cool before folding or preparing for transport.
2. Turn off and disconnect the LP cylinder from the regulator and remove from the grill.
3. Remove the Grease Pan and Foil Pan. Empty and clean then place in the grill body under the cooking grids.
4. Fold the side windscreens against the back then fold all flat to the cooking grids.
5. Close the side tables. First the right with the drain channel, then the left
6. Route the regulator hose straight back under the firebox and hang the regulator on the hook on the back of the firebox.
7. Unlock the latches, grasp the tubular handles by the "Gripping Portion" and lift the grill body off of the cart.
8. Carefully pull up slightly on each of the four leg lock brackets, just enough so they are barely starting to fold.
9. To avoid being pinched by hinges or moving parts, only close the cart by gripping the top of each leg frame. Gripping at the top of each leg frame, lower the leg frames inward and down until they rest flat on the cart base.
10. Place the grill body on top of the folded cart with the corners of the firebox inside the corner brackets on the cart.
11. Engage the latches on the grill body to the latch hooks on the cart.

Important Reminders

To get the most enjoyment and longest life from your Event Grill, please always remember the following items:

- Do not transport the grill in the "Set-Up" position.
- When folding or unfolding the cart, keep hands and fingers away from hinges, leg pivot points and moving parts.
- Always be sure latches are securely engaged when in either the "Set-Up" or "Transport" position.
- Always be sure the firebox handles are in the up and seated position before opening or using the side tables.
- Inspect the regulator and hose for damage, kinks or cuts before each use.
- Remove the grease pan before storage or transport.
- Secure the regulator hose under the grill body with the attached hook when transporting.
- When transporting an LP cylinder, be sure it is properly secured in an upright position, not in the passenger compartment, and follow all pertaining laws.
- Do not sit or ride on the grill.
- Cover the grill when stored for any length of time.

Connecting/Disconnecting the Gas

Using Gas

DANGER

Carbon Monoxide Hazard

- This appliance can produce carbon monoxide which has no odor. Using it in an enclosed space can kill you.
- Never use this appliance indoors, on recreational vehicles, or boats.

WARNING

To reduce the risk of serious bodily injury or death from fire or explosion:

- Use only propane gas with this LP gas grill.
- Do not attempt to convert this LP unit to natural gas.
- Always use a gas appliance outdoors in an open area with good ventilation to avoid breathing toxic fumes from combustion or leaking gas, explosion, or fire. As with all conventional fuels, the burning process consumes oxygen and produces toxic gases, including carbon monoxide. In addition, the combustion products of such fuels, including liquefied petroleum (LP), contain chemicals known to the state of California and other authorities to cause cancer, birth defects, and other reproductive harm.

Any use or alteration of this unit inconsistent with these instructions could be hazardous and will void your warranty.

LP Gas Cylinder

DANGER

- If you see, smell, or hear the hiss of LP gas escaping from the cylinder:
 1. Do not attempt to light appliance.
 2. Extinguish any open flame.
 3. Disconnect from fuel supply.

The LP Gas Cylinder, for use with this LP gas grill, must meet the following requirements:

1. 12" diameter x 18" tall, 20 lb. maximum capacity
2. Overfill Prevention Device (OPD) safety feature (should be noted on cylinder)
3. Must be constructed and marked in accordance with Specifications for LP Gas Cylinders of the U.S. Department of Transportation (DOT) or the National Standard of Canada, CAN\CSA-B339, Cylinders, Spheres and Tubes for Transportation of Dangerous Goods; and Commission, as applicable (See collar for marking)
4. Must have collar to protect LP Gas Cylinder valve.
5. Must be marked "PROPANE."
6. Must be provided with a cylinder connection device that is compatible with the grill's connection.

WARNING

To reduce the risk of serious bodily injury from fire or explosion:

- Read and follow all warnings on LP Gas Cylinder.
- Do not operate the LP gas grill without the LP Gas Cylinder secured to the cart and oriented as shown in Assembly Instructions for Connecting the LP Gas Cylinder.
- Never connect or disconnect LP Gas Cylinder or fittings while grill is in use or is hot.
- When the LP Gas Cylinder is connected, keep the grill outside in a well-ventilated space.
- Do not use an LP Gas Cylinder if it shows signs of dents, gouges, bulges, fire damage, corrosion, leakage, excessive rust, or other forms of visual external damage; it may be hazardous and should be checked by a liquid propane supplier. Do not use an LP Gas Cylinder with a damaged valve.
- Use only an LP Gas Cylinder equipped with an OPD (Overfill Prevention Device).
- Do not store a spare LP Gas Cylinder under or near the LP gas grill.
- When grill is not in use, turn off all grill Control Knobs, LP Gas Cylinder valve and disconnect LP Gas Cylinder.
- Never fill the LP Gas Cylinder more than 80% of cylinder volume. (20 lb. maximum) Do not ask the propane supplier to over-fill the Cylinder.
- If you obtain LP gas through a cylinder exchange dealer, make sure you get a safe and adequate cylinder. Use only a licensed LP Gas Cylinder dealer.

LP Hose and Regulator

⚠ WARNING

To reduce the risk of serious bodily injury or death from fire or explosion:

- Clean and inspect the gas hose/regulator before each use of the outdoor cooking gas appliance. The gas hose/regulator must be replaced prior to being used, if there is evidence of excessive abrasion or wear, or if the hose is cut or leaks.
- Use only the gas hose/regulator assembly that has been supplied with this gas grill. Do not use hose/regulator from another manufacturer. Replacement gas hose/regulator assembly must be specified by this grill's manufacturer before using.
- Always check for gas leaks when you connect and disconnect the hose/regulator to the LP Gas Cylinder, especially after a period of storage (for example, over winter).
- Make sure there are no sharp bends in the hose.
- Make sure the hose/regulator does not contact any heated surfaces.

NOTE: If the hose/regulator assembly is not working properly and you need a replacement, contact **Customer Service at 1-866-475-5180.**

Be sure to **have the grill model number and serial number** printed on the black label, located on the back face of the bottom tube of cart base. **If you need a replacement part under warranty, a proof of purchase will be necessary.** You will be asked to forward your proof of purchase and reference your model and serial number. **It is important to retain your receipt.**

Connecting LP Gas Cylinder

1. Fill empty OPD LP Gas Cylinder at your local gas supplier.
2. Place the bottom ring of the LP Gas Cylinder in the notches of the bracket on the left end of the cart base. Lock the LP Cylinder in place by lowering the wire onto the collar of the LP Cylinder.
3. Remove the protective cap from the LP Gas Cylinder valve. (Save cap for re-capping.)
Hold Regulator in a straight line with LP Gas Cylinder valve so the connection does not cross thread. Insert Regulator Nipple into the LP Gas Cylinder valve. Hand tighten coupling nut in clockwise direction. **DO NOT USE TOOLS.**

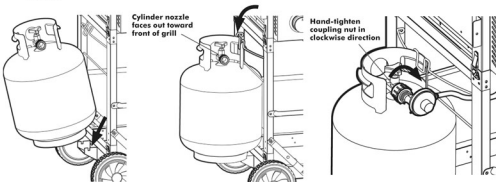

Disconnecting LP Gas Cylinder

1. Turn all Control Knobs to the "Off" position and turn the handle on the LP Gas Cylinder clockwise until it stops.
2. Turn coupling nut on regulator counterclockwise until regulator is released from the threaded LP Gas Cylinder nozzle.
3. Place the protective cap over LP Gas Cylinder nozzle.

Before Using Your LP Gas Grill

Installation Codes

WARNING

To reduce the risk of serious bodily injury or death from fire or explosion:

- This installation must conform with local codes or, in the absence of local codes, with either the National Fuel Gas Code, ANSI Z223.1/NFPA 54 Natural Gas and Propane Installation Code, CSA B149.1, or Propane Storage and Handling Code, B149.2 or the Standard for Recreational Vehicles, ANSI A 119.2/NFPA 1192 and CSA Z240 RV Series, recreational Vehicle Code, as applicable.
- If an external electrical source is utilized, the outdoor cooking appliance, when installed, must be electrically grounded in accordance with local codes or, in the absence of local codes, with the National Electrical Codes, ANSI/NFPA 70, or the Canadian Electrical Code CSA C22.1.
- Keep any electrical supply cord and the fuel supply hose away from any heated surfaces.

Selecting a Location

WARNING

To reduce the risk of serious bodily injury or death from fire or explosion:

- This outdoor cooking appliance must be used only outdoors and shall not be used in a building, garage, breezeway, carport, porch or in any enclosed area. Locate outdoor cooking appliance in an area with good ventilation on a level stable surface clear of combustible and flammable material.
- Locate your LP gas grill at least 10 feet away from your house or any building.
- Maintain minimum clearances of 36" from back and sides of grill to any combustible construction.
- Do not locate this appliance under overhead, unprotected combustible construction.
- This outdoor cooking appliance is not intended to be used in or on boats or installed in or on recreational vehicles.
- Never use gas grill as a space heater.

Performing A Leak Test

WARNING

To reduce the risk of serious bodily injury or death from fire or explosion:

- Perform a leak test before lighting your grill for the first time.
- Perform a leak test if any gas component is changed.
- Perform a leak test a minimum of once a season.
- Perform a leak test after a prolonged period of storage or non-use.
- Perform a leak test if the regulator flow-limiting device has been activated.
- Perform a leak test on the propane cylinder and exposed connections every time the propane cylinder is refilled or exchanged.
- Perform leak tests in a well ventilated area.
- Never use an open flame to test for gas leaks.
- Never smoke near the grill during a leak test.
- Do not perform a leak test on a grill while it is hot or in use.
- Do not use the gas grill if you detect a gas leak that cannot be corrected by using the leak test procedures.

Before using your gas grill, perform a leak test on the Control Valves, Hose/Regulator Connections, Fittings and LP Gas Cylinder.

How to Perform A Leak Test "FIRST TIME USE" and as required

Supplies Needed for a Leak Test:

- Clean paint brush
- Water
- Dish washing liquid
- Clean container

1. Use an LP Gas Cylinder equipped with an OPD (Overfill Prevention Device) and have it filled at an authorized LP gas dealer by a qualified attendant.
2. Make sure all grill Control Panel Knobs are turned to the "Off" position and verify that the LP Gas Cylinder valve is closed by turning the knob on the LP Gas Cylinder clockwise until it stops.
3. Mix one part of water with one part of dish washing liquid.
4. If already in place, remove the cooking grids and flavor activators. Open the Control Panel from the Grill Body/ Firebox by removing the four bolts from that attach the top of the control panel to the top of the firebox. (Fig. 1) Carefully lower Control Panel away from the Body until Valves disengage from the Tubular burner ends. The bolts in the bottom ends of the control panel act as hinge points. The control panel will stop opening at the horizontal position.

Screws inside front face of Firebox

Fig. 1

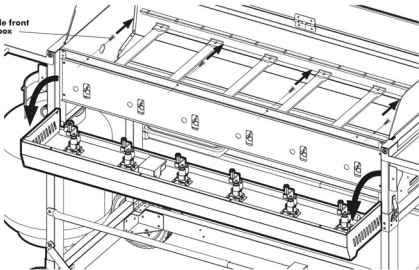

5. With the regulator hose connected to the LP Gas Cylinder, turn the knob on the Cylinder counterclockwise. (Fig. 2).

Fig. 2

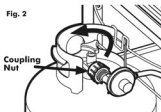

Check for leaks at
Cylinder Valve and
Regulator Connection
and Fittings

Fig. 3



6. Check for leaks by brushing the soap solution on all gas valves, hose connections and fittings. (Shown by the heavy arrows in Fig. 3 and 4) Make sure you generously brush the locations with the soap solution, completely surrounding the connections and fittings.

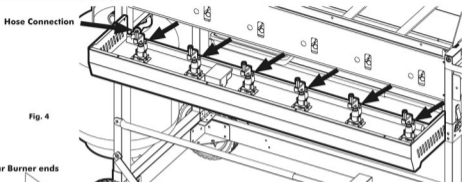

Tubular Burner ends

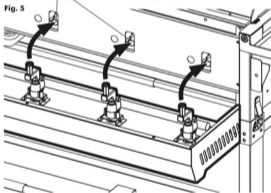

NOTE: After checking the connections and fittings in Figure 4, replace the control panel in the same manner as it was removed. Take special care to be sure the valve ends are inserted into the openings in the burner ends as shown in Figure 5. If all valve ends do not immediately align with the burner end openings, starting at one end, grasp the tube burner inside the firebox and gently move it until the valve seats in the open end.

7. If "growing" bubbles appear on any of the connection points, you have detected a gas leak. Immediately close the LP Gas Cylinder valve by turning handle clockwise
- If leak appears at either end of hose and regulator assembly, retighten the connection at the leak, but do not over-tighten. (NOTE: Only hand tighten at coupling nut in Fig. 2 shown on previous page) Repeat Leak Test.
 - If the leak is coming from the Gas Cylinder, from the valves at the Control Knobs, or if the leak cannot be stopped, do not use the grill. Call Customer Service at 1-866-475-5180 **have the grill model number and serial number** printed on the black label, located on the back face of the bottom tube of the cart base. **If you need a replacement part under warranty, a proof of purchase will be necessary.**
8. Upon completion of leak test, turn all Control Knobs to the "Off" position. Turn the handle on the LP Gas Cylinder clockwise until it stops. Disconnect LP Gas Cylinder by turning coupling nut on regulator in a counterclockwise direction until regulator is released from threaded LP Gas Cylinder nozzle.
9. Place the protective cap over LP Gas Cylinder nozzle.
10. Replace Control Panel and retighten all bolts. (Fig. 1)

Lighting the Grill Using the Pulse-Spark Ignitor

⚠ WARNING

To reduce the risk of death or serious injury from an explosion or a fire beneath the grill:

- Regularly inspect and clean Burner/Venturi Tubes for insects or insect nests. Spiders or small insects can build nests, webs, and lay eggs in the grill's Venturi Tubes, (Fig 12, page 20) obstructing the flow of gas to the Burner. The backed-up gas can ignite behind the Control Panel and cause a fire beneath the grill, posing the risk of death or serious bodily injury. This is known as a "flashback."
- Be sure Burners are re-installed properly before using grill.

Should you notice that your Burner(s) are getting hard to light or the flame is not as hot as it once was, refer to the "How to Clean your Burners" section on page 20, to remove any possible obstructions.

⚠ WARNING

To reduce the risk of serious bodily injury or death from fire or explosion:

- During failed lighting attempts, or if the Burners go out during operation, turn Control Knobs "Off" to dissipate any accumulation of gas. Wait five minutes before repeating lighting procedure.
- Light each burner from the left before lighting the next burning to prevent gas from accumulating.

1. **IMPORTANT:** Make sure Control Knobs are turned "Off." (Fig. 7)
2. Turn the LP Gas Cylinder valve open counterclockwise until it stops. (Fig. 8)

Control Knob in Off position

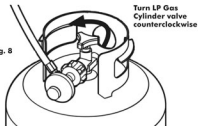

Fig. 7

Control Knob in High position (large flame symbol)



Fig. 8



Turn LP Gas Cylinder valve counterclockwise

Fig. 9

Left Main Burner Control Knob

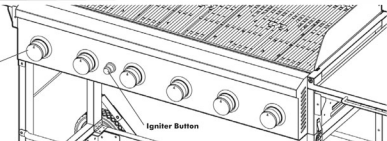

3. Push Burner Control Knob in on Control Panel and turn counterclockwise to the High position. (Figs. 7 and 9)

4. Push the Igniter Button in until the Burner is lit. Listen for the spark ignition, and look to make sure the Burner is lit. If no spark, first be sure the gap between the electrode and burner is $3/16"$ (Fig. 10). If still no spark see **Troubleshooting Section on page 23**.

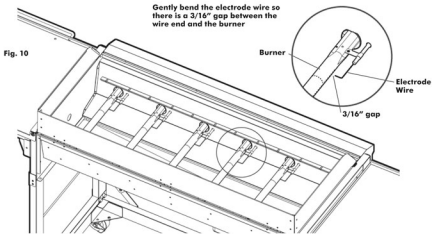

5. From the "Off" position, light all other Burners, making sure each Burner is lit before lighting the next. As in step 4, push the Igniter Button in until the Burner is lit. Each burner has its own igniter operated by the one igniter button.
6. If the Burner fails to light, repeat Steps 3 and 4.

If a Burner goes out during operation, turn all Control Knobs to the "Off" position and close the LP Gas Cylinder valve to dissipate any accumulated gas. Wait five minutes before attempting to relight the grill.

If one or all Burners fail to light after three to four attempts following Steps 3-4 turn all Control Knobs to the "Off" position and close the LP Gas Cylinder valve to dissipate any accumulated gas. Wait five minutes; then repeat the lighting procedures.

NOTE: If the Burners still fail to light, refer to the **Troubleshooting Section on page 23**. The Burner can also be lit manually, see

Manual Lighting of the Grill on page 16.

Manually Lighting the Grill

1. **IMPORTANT:** Make sure Control Knobs are turned "Off." (Fig. 7 - P.14)
2. Turn the LP Gas Cylinder valve open counterclockwise until it stops. (Fig. 8- P.14)
3. Using the Match Holder, Insert a lit match through the cooking grids near the burner to be lit. (Fig. 11)
4. Push in the far left Main Burner Control Knob and turn counterclockwise to the "High" position.
5. From the "Off" position, push Control Knob in and turn counter-clockwise to the high position and light all other burners from left to right using a match, making sure each burner is lit before lighting the next. Confirm each burner is lit before lighting another burner.

Fig. 11

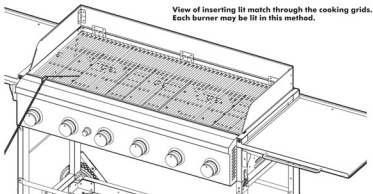

If any or all burners fail to light after three or four attempts following Steps 3-5, turn all Control Knobs to the "Off" position and close the LP Gas Cylinder valve to dissipate any accumulated gas. Wait five minutes; then repeat the lighting procedures.

NOTE: If the Burner still fails to light, refer to the **Troubleshooting Section**.

6. After ignition, turn the Control Knobs to "High" for 3-5 minutes to preheat the grill. Preheat the grill before every cooking session.

If a Burner goes out during operation, turn all Control Knobs to the "Off" position and close the LP Gas Cylinder valve to dissipate any accumulated gas. Wait five minutes before attempting to relight the grill.

Check the Flame

The Burners have been preset by the manufacturer for optimal flame performance. A blue flame, possibly with a small yellow tip, is the result of the optimal air and gas mixture.

Check the flame before each cooking session and throughout the grilling season. Check the flame, especially after long periods of storing the grill. If the flame is significantly yellow in color, the appropriate amount of LP gas in the air/LP gas mixture is not correct. This could be due to a blocked Burner from grease drippings or from insects building a nest inside the Burner or Burner opening. See **How to Clean the Burners**.

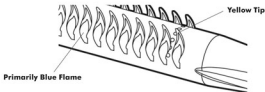

Cooking On the Gas Grill

WARNING

To reduce the risk of serious bodily injury or death from fire, explosion or burn hazard:

- Never use charcoal or lighter fluid in your gas grill. Keep this outdoor cooking appliance clear and free from combustible materials, gasoline, and other flammable vapors and liquids.
- Keep any electrical supply cord and regulator hose away from any heated surfaces.
- Make sure there are no gas leaks or obstructions to the flow of combustion and ventilation air before each use.
- Keep the ventilation openings of the LP Gas Cylinder enclosure free and clear from debris.
- Do not attempt to extinguish a grease fire with water or other liquids. Have an ABC or BC fire extinguisher readily accessible. Never douse or spray the grill or cooking surfaces with water when hot. Burns from grease or water splatters could occur.
- If your gas grill catches on fire:
 - If the fire is in the grill portion and you can safely reach the Control Knobs on the Control Panel, then turn them to the "Off" position.
 - If the fire is in one of the hoses, and you can safely reach the LP Gas Cylinder valve, then shut the valve off.
 - If the fire involves the LP Gas Cylinder, leave it alone, evacuate the area, and call the Fire Department.
 - If there is any type of fire that threatens either personal safety or endangers property, call the Fire Department.
- Do not use the grill without Bottom Panel and Grease Pan in place. Check the Foil Pan and Grease Pan for build-up. Empty excess grease to avoid a grease fire in the pan.
- If you notice grease or other hot material dripping from the grill onto the valve, hose, or regulator, turn off the gas supply immediately. After the grill has cooled, determine the cause and correct it. After cleaning the valve, hose, and regulator assembly, perform a leak test before continuing use. See **"Performing a Leak Test."**
- Do not operate a gas grill if you have knowledge of or suspect a gas leak.
- Do not wear loose clothing (example: hanging shirt tails, clothing with frills, etc.) around a gas grill while in use or hot.
- Do not lean your body over the gas grill when lighting it or while it is in use or hot.
- Do not touch hot surfaces. Use heat-resistant gloves, long-handled tongs, or cooking mitts at all times, since the grill will become very hot.
- Do not allow children to operate or play near a gas grill. Keep children, animals and bystanders out of the grill area. Do not leave grill unattended.
- Do not move an LP gas grill when in use or hot.
- When grill is not in use, turn off all grill Control Knobs, LP Gas Cylinder valve, and disconnect the LP Gas Cylinder.

Grill Cooking (Direct Method)

WARNING

To reduce the risk of serious bodily injury or death from fire or explosion:

- Do not cover more than half (50%) of the cooking area if using griddle plates. Full coverage of cooking area will cause overheating below the plates.
- Always make sure the Foil Pan, Grease Pan, and Bottom Panel are empty and are properly installed under the Bowl before each cooking.
- Do not leave any utensils or cookware on a hot cooking surface.

Grill Cooking (Direct Method)

Direct Cooking on the Grids:

Food is cooked directly over the heat source. The Burners heat up the Flavor Activators under the Cooking Grids, which in turn heat the food on the grill. The natural food juices from cooking fall onto the hot Flavor Activators below and vaporize. Rising smoke bastes the food, giving it that unique barbecued flavor.

Use the Direct Cooking method for foods that take less than 25 minutes to cook: steaks, chops, kabobs, sausages, and more.

These foods should be turned once halfway through the grilling time.

To sear meats, place them over Direct High heat for 2 to 5 minutes per side. Smaller pieces require less searing time. Hamburgers, steaks, chops, chicken breasts, and larger cuts of meat all benefit from searing. Usually after searing you finish cooking the food at a lower temperature.

For Direct Cooking, preheat the grill with the Main Burners on "High." Place food on the Cooking Grate, and then adjust all Burners to the temperature required.

Cooking on Griddle Plates allows cooking of smaller items that otherwise would fall through the grill. The Burners heat the Griddle Plates directly, which cooks the food on contact. The Griddle Plates sear thin cuts of meat or cook food like eggs that can not be cooked on a grill. They can also be used to heat pans.

CAUTION

Do not preheat Cooking Grids over 5 minutes. The cooking surface coatings could be destroyed.

Use only long-handled heat-resistant plastic or wooden utensils to avoid scratching the non-stick surface.

End of Cooking Session

WARNING

To reduce the risk of serious bodily injury or death from fire or burn hazard:

- Allow grill and the grease in the Foil Pan to completely cool before emptying, handling parts, cleaning, moving, or storage.
- Empty the Foil Pan and Grease Pan after each cooking session so excessive grease does not accumulate.
- Never light the LP gas grill without the Foil Pan, Grease Pan, and Bottom Panel in place.

1. After each cooking session, turn the Burners to the "High" position and burn for five minutes. This will burn off some cooking residue, thus making cleaning easier.
2. When you have finished using your grill, turn the Control Knobs clockwise to the "Off" position.
3. Turn off the gas at the LP Gas Cylinder valve by turning the handle clockwise until it stops.
4. Wait until the grill is cool before closing the side tables, cleaning, preparing for transport or putting on a grill cover.
5. Regularly clean your LP gas grill between uses and after extended storage periods. To maintain the condition and extend the life of your grill, we strongly recommend that the unit be covered when stored for **any** length of time.

CAUTION

To reduce the risk of a laceration hazard, wear protective gloves when handling parts that have sharp edges.

Cleaning the Grill

Bottom Body Panel, Grease Pan, Foil Pan:

Remove the Bottom Body Panel. (page 21) Scrape away food and fat residue from the Bottom Panel. Empty and wash the Foil Pan and Grease Pan with hot soapy water and a cloth. The Foil Pan can be replaced with a standard size foil pan. (approx. 5-1/2" W x 8-1/2" L x 1-1/8" H) from your local grocer or retail store.

Grill Body and Cart:

Do not mistake the accumulation of grease and smoke residue for peeling or flaking paint. Remove excess grease and/or fat with a soft plastic or wooden scraper. Do not use steel wool or other abrasive cleaners that can scratch painted, porcelain-coated, or stainless steel surfaces. It is not necessary to remove all the grease from the body. When grill is cool, wipe it down with paper towels or soft damp cloth.

Cooking Grids/Flavor Activators:

Clean the residue off with a baking soda and water solution. For stubborn stains, use a non-abrasive scouring powder. Do not use steel wool or other abrasive cleaners that can scratch the porcelain-coated surfaces. This can cause foods to stick on the Cooking Grids.

All Other Cleaning:

For further cleaning, use hot soapy water and a cloth, or nylon-bristled brush only. Do not immerse the Gas Controls or Manifold in water. (Avoid getting water in the Burner holes.)

Burners:

Burning off the residue after cooking will keep the Burners clean with normal usage, provided the Burners are operating correctly. Clean the Burners annually, or whenever heavy build-up is found, to ensure that there are no signs of blockage (debris, insects) in the Burner portholes, the primary air inlet, or the neck of the Burners. See **How to Clean the Burners**.

After cleaning, replace all the cleaned parts. Replace Bottom Body Panel screws.

WARNING

To reduce the risk of death or serious injury from an explosion or a fire beneath the grill:

- Inspect and clean Burner/Venturi Tubes for insects or insect nests. Spiders or small insects can build nests, webs, and lay eggs in the grill's Venturi Tubes, (Fig 15) obstructing the flow of gas to the Burner. The backed-up gas can ignite behind the Control Panel and cause a fire beneath the grill, posing the risk of death or serious bodily injury. This is known as a "flashback."
- Be sure Burners are re-installed properly before using grill.

Should you notice that your Burner(s) are getting hard to light or the flame is not as hot as it once was, refer to the **"How to Clean your Burners"** section to remove possible obstructions.

In order to prevent flashbacks, the Burner(s) should be removed from the grill and cleaned periodically, especially if the grill has been stored for an extended period of time.

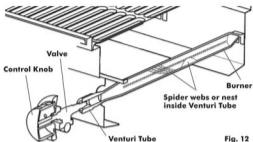

Fig. 12

How to Clean the Burners

1. Make sure the Control Knobs are turned "Off" and the grill is completely cooled.
2. Carefully remove Cooking Grids and Flavor Activators.
3. To remove each Main Burner, first remove the screw that fastens the burner flange to the firebox. (Fig. 13)
4. Gently lift the rear of the Burner. (Fig. 13) Slide the Burner towards the grill back to move the Venturi Hole off of the Valve nozzle. (Fig. 14) Lift each Main Burner from the grill. To completely remove the burner from the grill, disconnect the electrode wire from the back of the igniter box behind the control panel and carefully pull the wire through the inside of the firebox.

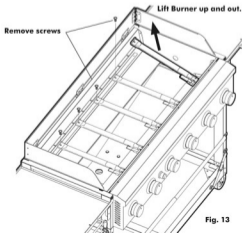

Fig. 13

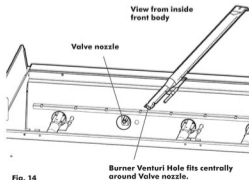

Fig. 14

- Use a pipe cleaner to clear insect nests from the inlet hole of Burner (Fig. 15)
- Open up the Burner holes (Fig. 15) with a small nail or wire. Use a **non-metallic brush** to remove food particles and corrosion from the Burner surface:

Fig. 15

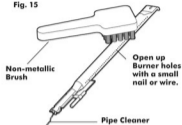
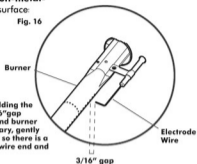

Fig. 16

Make sure the screw holding the electrode is tight so $3/16''$ gap between electrode tip and burner is maintained. If necessary, gently bend the electrode wire so there is a $3/16''$ gap between the wire end and the burner



- Check the Electrode mounting on each burner to see if it is loose. If so, tighten the screw holding the Electrode to maintain $3/16''$ gap between Electrode tip and burner.

NOTE: Before next step, you may wish to clean the rest of the grill. See **Grill Body and Cart** (p. 19).

- After cleaning, refit the burners.

NOTE: When refitting the burners, be sure each burner is positioned correctly. The valves should protrude inside the Venturi ends of the burner. (Figs. 12 & 14) Replace the screws that fasten the burner flange to back wall.

- If the grill is to be stored, wrap burners in a protective cover, such as aluminum foil, to keep insects out.
- Check burner operation after re-assembly.
- Replace Flavor Activators and Cooking Grids.

Bottom Body Panel Removal

The Bottom Body Panel may be removed for cleaning. First remove the Grease Pan containing the Foil Pan. Next remove the crossbrace at the bottom back of the firebox. Remove the one screw at each end and slide the Bottom Body Panel out the back of the firebox.

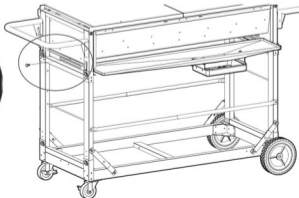
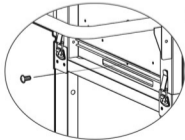

Storage and Transportation

WARNING

To reduce the risk of serious bodily injury or death:

- Store your LP gas grill in a cool dry place. Do not store an LP Gas Cylinder in a space greater than 125 degrees Fahrenheit. Never store a connected LP Gas Cylinder in a building, garage, or any enclosed area.
- Store LP Gas Cylinders outdoors out of reach of children.
- Never leave a LP Gas Cylinder inside a vehicle that can become overheated by the sun.
- Even though your LP Gas Cylinder may appear to be empty, gas may still be present and the LP Gas Cylinder should be transported and stored accordingly.
- Never store a spare LP Gas Cylinder under or near the LP gas grill.
- Always turn off the LP Gas Cylinder at the LP Gas Cylinder valve when the gas grill is not in use.

1. Disconnect LP Gas Cylinder from grill and store outside, in a dry, well-ventilated area, away from any sources of heat or ignition. Re-cap LP Gas Cylinder valve with the Safety Cap.
2. Remove Burners and wrap with aluminum foil to prevent insects from entering the Burner holes. Store wrapped Burners in body of grill.
3. You may wrap the Cooking Grid and Flavor Activators in aluminum foil and place inside the grill body or store inside your dwelling.
4. Place a grill cover over the grill and store outdoors if possible. It may be stored indoors only if the LP Gas Cylinder is disconnected from the gas grill and stored outside.
5. Before next use, remove aluminum foil and reinstall Burners, Flavor Activators, and Cooking Grids.
6. Before using the grill after periods of storage or non-use (i.e. over winter), check your LP gas grill for gas leaks, deterioration, proper assembly, and Burner obstructions.
7. Periodically check and tighten all nuts, bolts, and screws.

CAUTION

To reduce the risk of bodily injury or property damage:

- Never transport your grill in the "Set-Up" position.
- Always lock the casters, block the wheels and secure the grill from moving when transporting.
- Always be sure latches are securely engaged when in either the "Set-Up" or "Transport" position.
- When transporting an LP cylinder, be sure it is properly secured in an upright position, not in the passenger compartment and follow all pertaining laws.

Emergencies

Problem	Possible Cause	Solution
Gas leaking from cracked/cut/burned hose	Damaged hose	Turn off gas at the LP Gas Cylinder. Replace valve/hose regulator before continuing use.
Gas leaking from LP Gas Cylinder	Mechanical failure due to rust or mishandling	Replace LP Gas Cylinder.
Gas leaking from LP Gas Cylinder valve	Failure of valve from mishandling or mechanical malfunction	Turn off LP Gas Cylinder valve. Return Cylinder to gas supplier.
Gas leaking between LP Gas Cylinder and regulator connection	Improper installation, connection not tight, failure of seal on LP Gas Cylinder valve	Turn off LP Gas Cylinder valve. Re-install correctly or tighten coupling nut. Replace Cylinder if seal is damaged. See "Leak Test" and "Connecting Regulator to LP Gas Cylinder" sections.
Fire coming through Control Panel	Fire in or around Venturi tube section of Burner	If you can safely reach the Control Panel, turn off Control Knobs, then close the LP Gas Cylinder valve. Once fire is out and grill has cooled off, remove Burner(s) and inspect for blockage from spider webs/insect nests or rust. See "How to Clean Burners" section. Replace any damaged parts.
Grease fire or excessive flames above cooking surface	Too much grease build-up in Burner section	Turn off Control Knobs and LP Gas Cylinder valve. Once fire is out and grill has cooled off, clean residual food particles and excess grease from inside firebox area, grease cup, and other surfaces.
Flashback (Fire in or around Venturi tubes)	Clogged or blocked Venturi tube	If you can safely reach the Control Panel, turn Control Knobs to "Off," then close the LP Gas Cylinder valve. Clean Burner and Venturi tubes. See "How to Clean Burners" section.

Troubleshooting

Problem	Possible Cause	Solution
Burners will not light using the igniter	Burners not assembled correctly	See re-assembly after cleaning in "Care and Maintenance."
	Not holding igniter switch long enough for pulse spark	When lighting the first (LEFT MOST) Burner, push Control Knob in and turn counterclockwise to the "High" position. Depress the Igniter Button until the Burner lights.
	No spark, electrode cracked, broken or loose.	<ol style="list-style-type: none"> 1. Make sure all the wires are connected to the terminals. 2. If Electronic, check the battery. Make sure it is pushed in the holder. 3. Electrode wire is bent (making too large or small of a gap between the electrode wire and burner). By hand, bend electrode wire back within a maximum of 3/16" gap to burner. (Page 15) 4. Tighten Electrode mounting screws. 5. Replace damaged Electrodes.
	LP gas cylinder is empty	Take LP Gas Cylinder to licensed LP gas supplier to be refilled.

Troubleshooting

Problem	Possible Cause	Solution
	Regulator coupling nut is not fully connected to LP cylinder	Tighten coupling nut by hand about one-half to three quarters additional turn. Do not use tools.
	LP-Excess flow valve tripped in regulator	Turn Control Knobs to "Off" position and turn LP Gas Cylinder handle clockwise until it stops. Wait five minutes. Relight LP gas grill. If flame continues to be low, turn off gas at LP Gas Cylinder and grill. Disconnect the regulator from the LP Gas Cylinder. Reconnect the regulator to the LP Gas Cylinder. This will reset the excess flow valve Perform a leak test. Relight grill.
	Vapor lock in connections	
	Obstructions in Burners	Clean the Burners. See "How to Clean Burners" in Care and Maintenance .
	Wet Electrodes and Burners	Dry Electrode with clean cloth. Air dry or use blow dryer.
	Wire loose or disconnected	Reconnect the wire.
	Wire shorting (sparking between Igniter and Electrode)	Replace Igniter Wire/Electrode assembly. (Call the Customer Service Department)
Burners will not light using a match	Burners not assembled correctly	See re-assembly after cleaning in Care and Maintenance .
	LP Gas Cylinder is empty	Take LP Gas Cylinder to licensed LP gas supplier to be refilled.
	LP-Excess flow valve tripped in regulator	Turn Control Knobs to "Off" position and turn LP Gas Cylinder handle clockwise until it stops. Wait five minutes. Relight LP gas grill. If flame continues to be low, turn off gas at LP Gas Cylinder and grill. Disconnect the regulator from the LP Gas Cylinder. Reconnect the regulator to the LP Gas Cylinder. This will reset the excess flow valve Perform a leak test. Relight grill.
	Regulator Coupling nut is not fully connected to LP Gas Cylinder	Tighten Regulator Coupling nut by hand about one-half to three quarters additional turn. Do not use tools.
	Obstructions in Burners	See "How to Clean Burners" in Care and Maintenance .
Low flame or low heat	LP-gas in LP Gas Cylinder is low	Check LP Gas Cylinder. Refill if necessary.
	Excess flow valve tripped in regulator	Turn Control Knobs to "Off" position and turn LP Gas Cylinder handle clockwise until it stops. Wait five minutes. Relight LP gas grill. If flame continues to be low, turn off gas at LP Gas Cylinder and grill. Disconnect the regulator from the LP Gas Cylinder. Reconnect the regulator to the LP Gas Cylinder. This will reset the excess flow valve Perform a leak test. Relight grill.
Flames blow out	High or gusting winds	Turn front of grill away from wind or increase flame height.
	Gas in LP cylinder is low	Check LP Gas Cylinder. Refill if necessary.
	Excess flow valve tripped	See "Low flame" problem above.

Problem	Possible Cause	Solution
Flare up	Grease build-up	Clean grill.
	Excessive fat in meat	Trim fat from meat before grilling.
Persistent grease fire	Grease trapped around burner system	Turn Control Knobs "Off" and turn handle of LP Gas Cylinder clockwise until it stops. Carefully and let fire burn out. After the grill cools, remove and clean all parts.
Unable to fill LP tank	Some dealers have older fill nozzles with worn threads	The worn nozzles do not have enough "bite" to engage the valve. Try another licensed LP dealer.
Humming or whistling from regulator	Outside temperature, humidity, barometric pressure, and the gas level within the tank may cause the rubber diaphragm inside the regulator to vibrate, making a humming or whistling sound.	Although this sound may be alarming, this is NOT dangerous as long as it is not accompanied by the smell of gas. Simply adjust the Burner settings, and usually the sound will subside. If the humming sound persists, a change in atmospheric conditions will eventually stop the vibration.

If your problem is not resolved from the information provided above, please call Customer Service at 1-866-475-5180.

If you need a replacement part under warranty, a proof of purchase will be necessary.

IMPORTANT NOTICE

The Gas Grill is set up to operate with a LP Gas Cylinder equipped with an OPD (Overfill Prevention Device).

This is a secondary device to prevent overfilling your LP Gas Cylinder. The proper methods for the filling of your LP Gas Cylinder are by weight or volume, as described in NFPA 58. Please make sure your filling station fills your LP Gas Cylinder by weight or volume. Ask your filling station to read purging and filling instructions on the LP Gas Cylinder before attempting to fill.



Rises up while filling, then stops when full.

WARNING

Do not exchange the LP Gas Cylinder unless the exchange LP Gas Cylinder is equipped with an OPD. Otherwise you will lose the OPD (Overfill Prevention Device) feature. If there is not an LP Gas Cylinder available for exchange equipped with an OPD, we recommend that you have your LP Gas Cylinder filled at an authorized LP gas dealer by a qualified attendant.

Parts Illustration

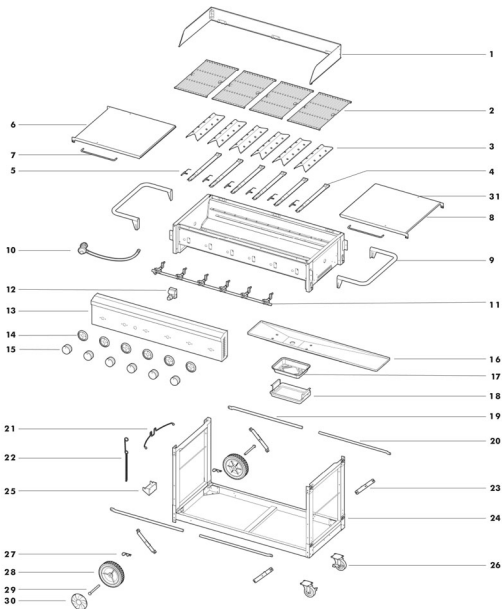

Parts List

Key	Description	Quantity
1	Windscreen	1
2	Cooking Grid	4
3	Flavor Activator	6
4	Burner	6
5	Electrode (wire not shown)	6
6	Left Side Table	1
7	Side Table Handle	2
8	Right Side Table	1
9	Firebox Handle	2
10	Regulator	1
11	Manifold Assembly	1
12	Ignition Box	1
13	Control Panel	1
14	Control Knob Bezel	6
15	Control Knob	6
16	Bottom Body Panel	1
17	Foil Pan	1
18	Grease Pan	1
19	Large Sliding Tube	2
20	Small Sliding Tube	2
21	Cylinder Retaining Wire	1
22	Match Holder/Chain	1
23	Locking Brace	4
24	Folding Cart Frame	1
25	Cylinder Bracket	1
26	Locking Caster	2
27	Axle Cotter Pin	2
28	Wheel	2
29	Axle	2
30	Hubcap	2

Not Pictured

31	Side Table Bumpers	4
32	Windscreen Bolts	6
33	Windscreen Nuts	6
34	Side Table Bolts	4
35	Sliding Tube Bolts	4
36	Locking Brace Bolts	4

When ordering parts, it is **VERY important to have the complete Model Number** to receive the correct replacement parts for your grill.

If you need replacement parts, refer to the Parts Illustrations to find the exact parts you need. If you have any questions or need help, contact **Customer Service at 1-866-475-5180**.

Be sure to have the grill model number and serial number printed on the black label, located on the back face of the bottom tube of the cart base. **If you need a replacement part under warranty, a proof of purchase will be necessary.** You will be asked to forward your proof of purchase and reference your model and serial number. **It is important to retain your receipt.**

Hardware Pack

Description	Quantity
1/4-20 x .47" Bolt	2
1/4-20 x .5" Bolt	8
1/4-20 Shoulder Bolt	4
1/4-20 Hex Nut	4
Axle Pin	4
Wheel Axles	2



Limited Warranty

This Grill is guaranteed against broken or damaged parts at time of purchase. All parts carry a 1-year limited warranty. Paint is guaranteed to be free of defects for 90 days except for rust, which may appear after repeated use.

This warranty does not cover damage or issues related to neglect, abuse, or modifications to the product. Repair labor is not covered.

All parts that meet the warranty requirements will be shipped at no-charge via the discretion of the Customer Service Department (ground shipments, US Mail, or Parcel Post Only). Any special handling charges (i.e. Second Day, Overnight, etc.) will be the responsibility of the consumer.

All warranty claims apply only to the original purchaser and require a proof of purchase verifying purchase date. Do not return parts to our address without first obtaining a return authorization number from our customer service.

This service is available by calling 866-475-5180, 8:30am to 4:30pm, Central Time, Monday through Friday, or write to Outdoor Leisure Products, Inc. 5400 Doniphan Drive, Neosho, MO 64850.

This warranty may give you specific legal rights that vary by state.

Outdoor Leisure Products, Inc.
5400 Doniphan Drive
Neosho, MO 64850
www.olp-inc.com

©2009 Outdoor Leisure Products, Inc. logo is a trademark and is not to be used without express permission by Outdoor Leisure Products, Inc.

Made by OLPI under License from Meco Corporation