

# ASSEMBLY INSTRUCTION

ITEM NO.:K6909

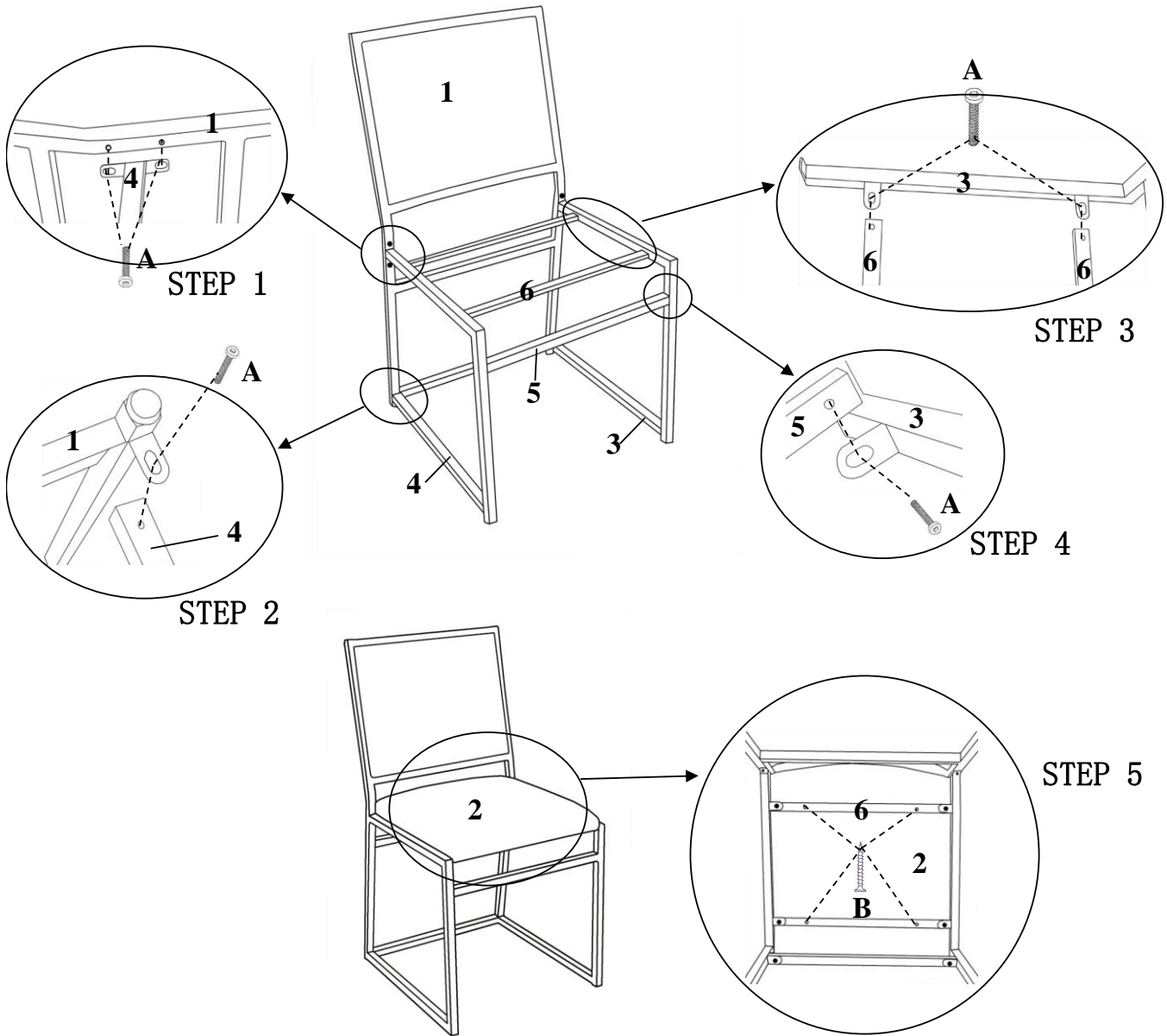

## PARTS IDENTIFICATION

|   |           |     |   |            |      |
|---|-----------|-----|---|------------|------|
| 1 |           | 1PC | 2 |            | 1PC  |
| 3 | <br>right | 1PC | 4 | <br>left   | 1PC  |
| 5 | <br>front | 1PC | 6 | <br>bottom | 2PCS |

## HARDWARE IDENTIFICATION

|   |                          |       |   |                          |      |
|---|--------------------------|-------|---|--------------------------|------|
| A | <br>$\phi 6*12\text{mm}$ | 12PCS | B | <br>$\phi 4*30\text{mm}$ | 4PCS |
| C | <br>4mm                  | 1PC   |   |                          |      |

## **ATTENTION:**

**WHEN YOU ASSEMBLE, PLEASE TIGHTEN THE SCREWS UNTIL ALL SCREWS ARE LINEAR.**