

HILTI

Operating instructions

Mode d'emploi

Manual de instrucciones

SID/SIW 14-A/18-A

en

fr

es



1

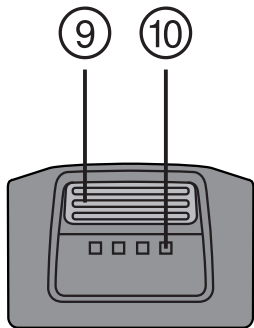
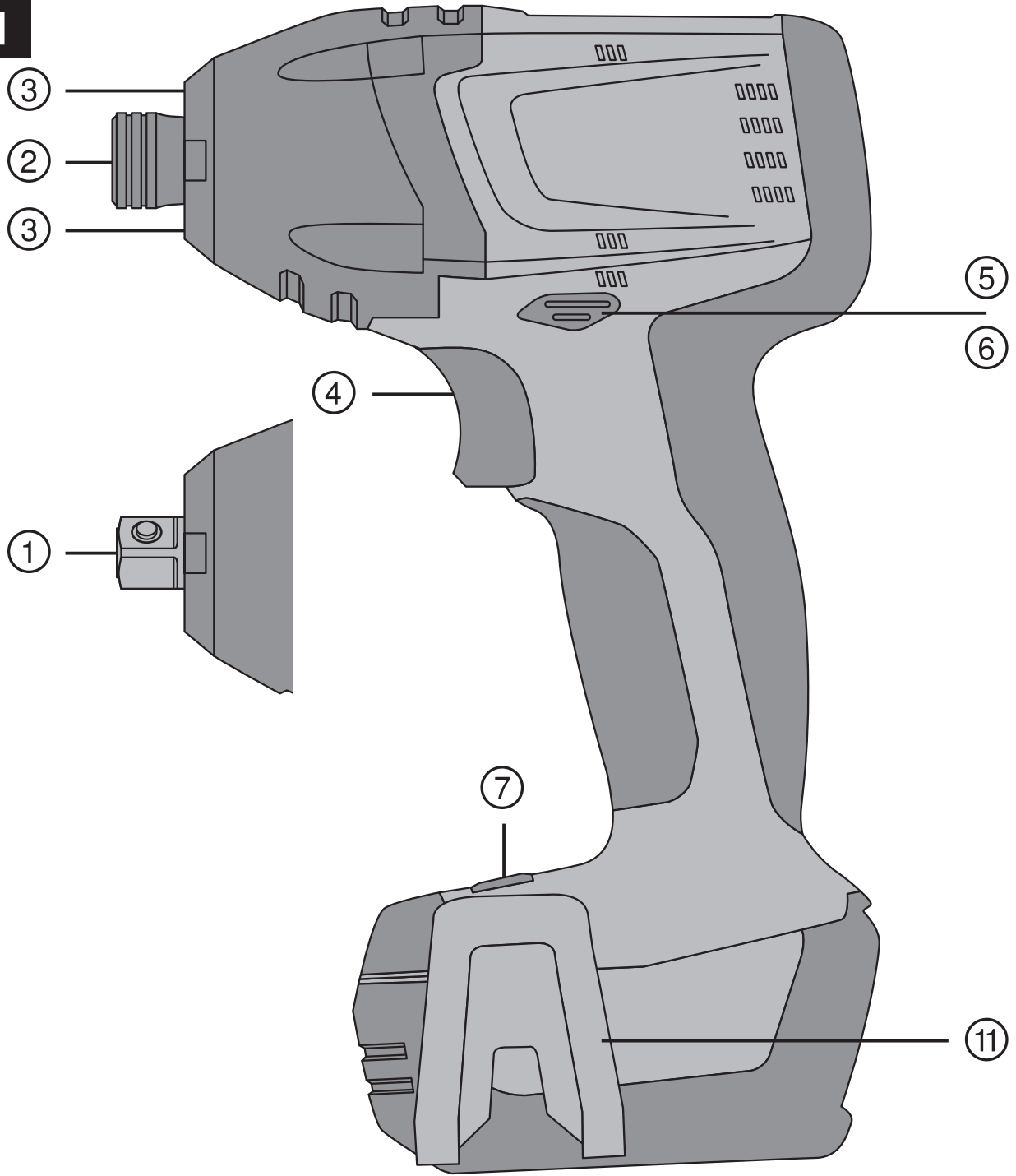

B14 1.6Ah

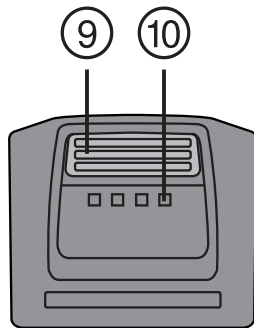

B14 3.3Ah

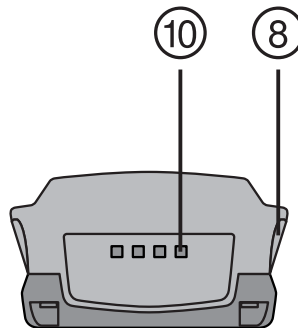

B18 1.6Ah

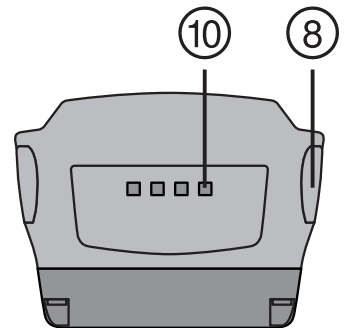

**B18 2.6Ah
B18 3.3Ah**

ETL listed to US and Canadian safety standards
Homologué ETL (conforme aux normes de sécurité américaines et
canadiennes)
Producto homologado según normas de seguridad americanas y
canadienses
Produto homologado de acordo com as normas de segurança
americanas e canadianas



2

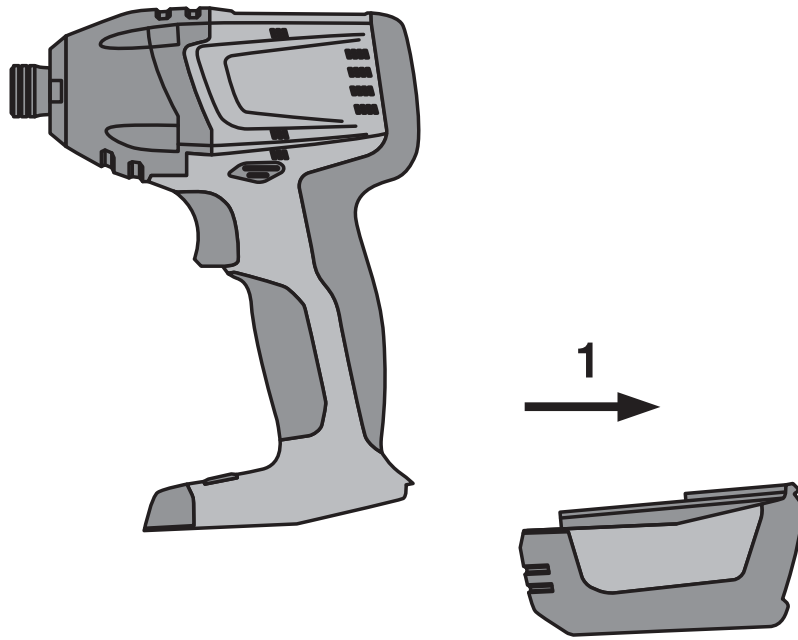

3

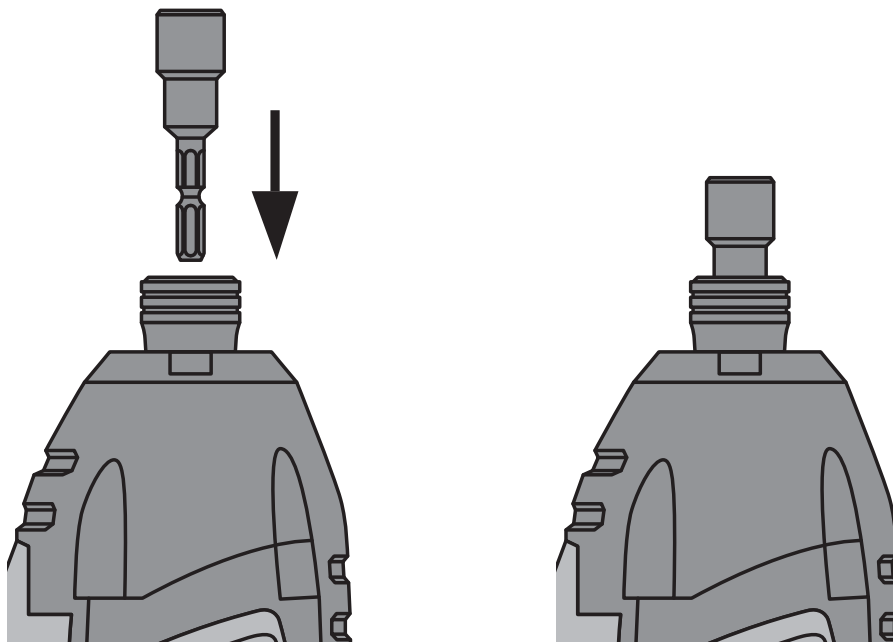

4

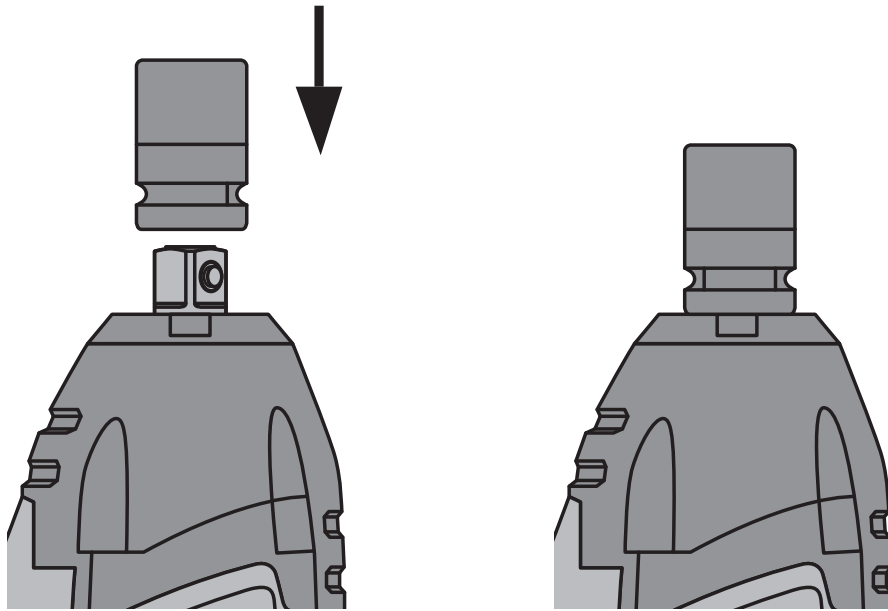

5

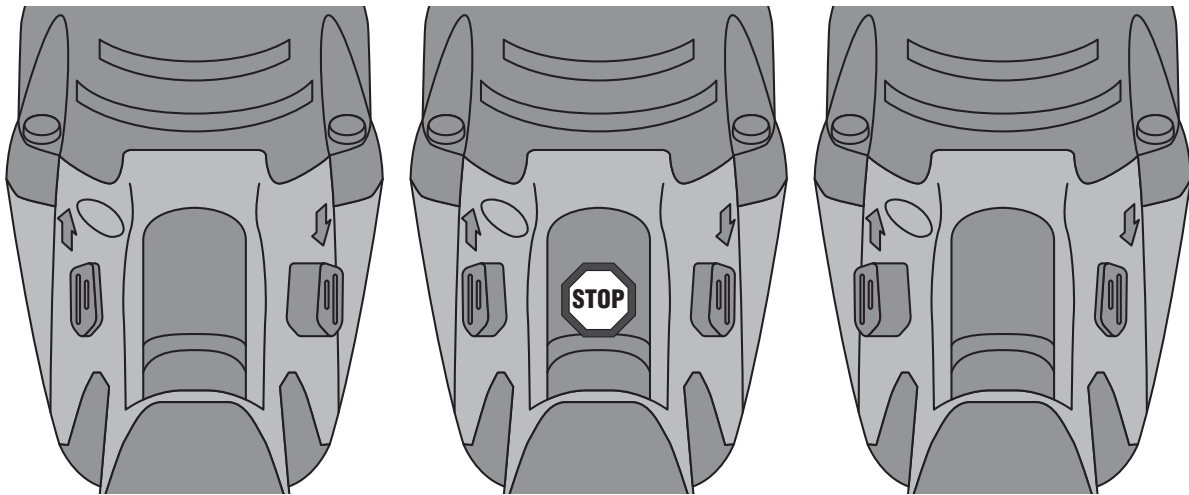

6

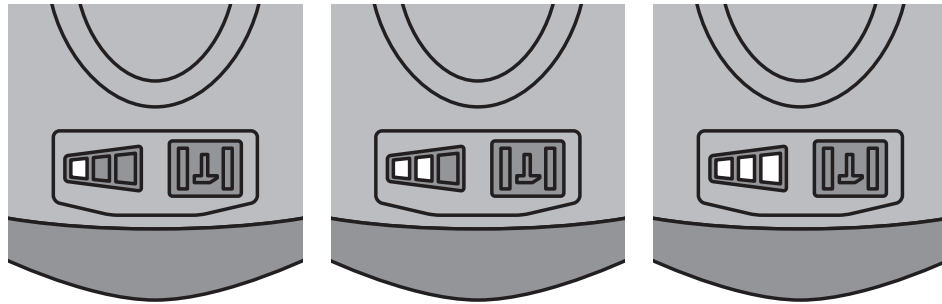

7

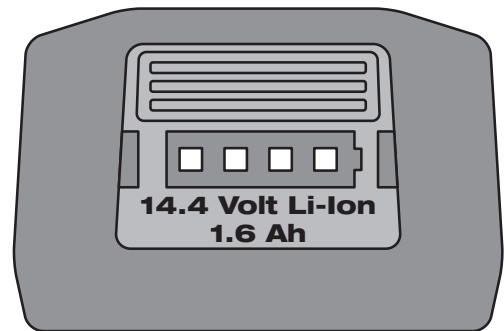
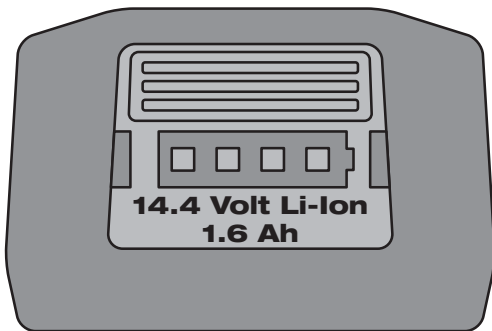

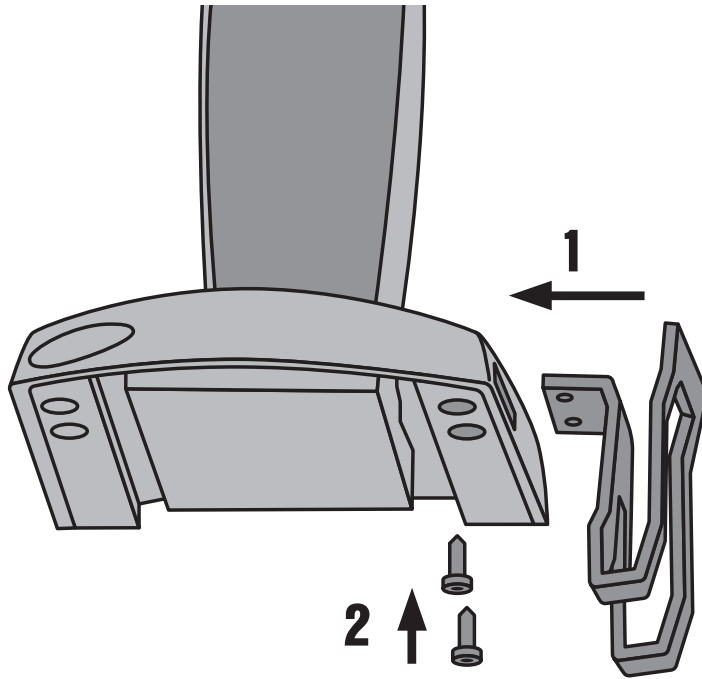

ORIGINAL OPERATING INSTRUCTIONS

SID 14-A / SID 18-A / SIW 14-A / SIW 18-A cordless impact driver/wrench

en

It is essential that the operating instructions are read before the power tool is operated for the first time.

Always keep these operating instructions together with the power tool.

Ensure that the operating instructions are with the power tool when it is given to other persons.

| Contents | Page |
|-------------------------------------|------|
| 1. General information | 1 |
| 2. Description | 2 |
| 3. Insert tools, accessories | 3 |
| 4. Technical data | 4 |
| 5. Safety instructions | 5 |
| 6. Before use | 8 |
| 7. Operation | 9 |
| 8. Care and maintenance | 11 |
| 9. Troubleshooting | 12 |
| 10. Disposal | 12 |
| 11. Manufacturer's warranty - tools | 13 |

❶ These numbers refer to the corresponding illustrations. The illustrations can be found on the fold-out cover pages. Keep these pages open while studying the operating instructions.

In these operating instructions, the designation “the power tool” always refers to the SIW 14-A, SIW 18-A, SID 14-A or SID 18-A cordless impact wrench / screwdriver with battery fitted.

Operating controls and parts ❶

- ❶ SIW square drive
- ❷ SID hex. socket drive
- ❸ Light
- ❹ Control switch (with electronic speed control)
- ❺ Forward / reverse switch
- ❻ Motor brake
- ❼ Torque selector switch
- ❽ SID/W 18-A battery release buttons
- ❾ SID/W 14-A battery release button
- ❿ Charge status and fault display (Li-ion battery)
- ⓫ Belt hook (optional)

1. General information

1.1 Safety notices and their meaning

DANGER

Draws attention to imminent danger that will lead to serious bodily injury or fatality.

WARNING

Draws attention to a potentially dangerous situation that could lead to serious personal injury or fatality.

CAUTION

Draws attention to a potentially dangerous situation that could lead to slight personal injury or damage to the equipment or other property.

NOTE

Draws attention to an instruction or other useful information.

1.2 Explanation of the pictograms and other information

Warning signs



General warning



Warning: electricity



Warning: caustic substances

Obligation signs



Wear eye protection



Wear a hard hat



Wear ear protection



Wear protective gloves



Wear breathing protection

Symbols



Read the operating instructions before use



Return waste material for recycling.



Volts



Direct current

n_0

Rated speed under no load

/min

Revolutions per minute

RPM

Revolutions per minute

Location of identification data on the power tool

The type designation can be found on the type identification plate and the serial number on the side of the motor housing. Make a note of this data in your operating instructions and always refer to it when making an enquiry to your Hilti representative or service department.

Type: _____

Generation: 01 _____

Serial no.: _____

2. Description

2.1 Use of the product as directed

The SID 14-A, SIW 14-A, SID 18-A and SIW 18-A are hand-held cordless impact screwdrivers/wrenches. They are designed for driving and removing screws in wood, metal, masonry and concrete and for tightening and releasing nuts and bolts.

Working on materials hazardous to the health (e.g. asbestos) is not permissible.

Do not use the battery as a power source for other unspecified appliances.

Modification of the power tool or tampering with its parts is not permissible.

To avoid the risk of injury, use only genuine Hilti accessories and insert tools.

The power tool should not be used for applications that require a precise torque. For applications that require a precise torque or where only a special limited torque is permitted, there is a risk of over-tightening and damage to the screw or workpiece. For these types of application, use a tool with a predefined torque setting to prevent over-tightening.

Observe the information printed in the operating instructions concerning operation, care and maintenance.

The power tool is designed for professional use and may be operated, serviced and maintained only by trained, authorized personnel. This personnel must be informed of any special hazards that may be encountered. The power tool and its ancillary equipment may present hazards when used incorrectly by untrained personnel or when used not as directed.

The working environment may be as follows: construction site, workshop, renovation, conversion or new construction.

Nationally applicable industrial safety regulations must be observed.

2.2 The items supplied include (toolbox versions):

- 1 Power tool
- 1 Operating instructions
- 1 Hilti toolbox

en

2.3 The items supplied include (cardboard box versions):

- 1 Power tool
- 1 Operating instructions

2.4 Additional items required for operating the tool

B 18/1.6 Li-ion, B 18/2.6 Li-ion, B 18/3.3 Li-ion, B 14/1.6 Li-ion or B 14/3.3 Li-ion battery with C 4/36, C 4/36-ACS or C 4/36-ACS TPS charger.

2.5 Li-ion battery charge status

| LEDs light constantly | LEDs blink | Charge status C |
|-----------------------|------------|------------------------|
| LED 1,2,3,4 | - | $C \geq 75 \%$ |
| LED 1,2,3 | - | $50 \% \leq C < 75 \%$ |
| LED 1,2 | - | $25 \% \leq C < 50 \%$ |
| LED 1 | - | $10 \% \leq C < 25 \%$ |
| - | LED 1 | $C < 10 \%$ |

3. Insert tools, accessories

| Designation | Short designation | Description |
|------------------------------|---|-------------|
| Bit holder | | S-BH 50 |
| Charger for Li-ion batteries | C 4/36-ACS | |
| Charger for Li-ion batteries | C 4/36 | |
| Battery | B 14/3.3, B 14/1.6 Li-Ion | |
| Battery | B 18/1.6 Li-ion | |
| Battery | B 18/2.6 Li-ion | |
| Battery | B 18/3.3 Li-ion | |
| Designation | Description | |
| Bits | Hex. bit, bit adapter, drill bits with hex. shank | |
| Sockets | Impact wrench sockets | |

4. Technical data

Right of technical changes reserved.

en

| Power tool | SID 14-A | SIW 14-A | SID 18-A | SIW 18-A |
|---------------------------------------|---|--|---|--|
| Rated voltage | 14.4 V | 14.4 V | 21.6 V | 21.6 V |
| Weight (including battery and chuck) | 1.3 kg (2.87 lb) | 1.3 kg (2.87 lb) | 1.5 kg (3.31 lb) | 1.5 kg (3.31 lb) |
| Dimensions (L x W x H) | 151 mm (5.94") x 81 mm (3.19") x 228 mm (8.98") | 154 mm (6.06") x 81 mm (3.19") x 228 mm (8.98") | 151 mm (5.94") x 94 mm (3.7") x 228 mm (8.98") | 154 mm (6.06") x 94 mm (3.7") x 228 mm (8.98") |
| Rated no-load running speed, pos. I | 0...1,000/min | 0...1,000/min | 0...1,000/min | 0...1,000/min |
| Rated no-load running speed, pos. II | 0...1,500/min | 0...1,500/min | 0...1,500/min | 0...1,500/min |
| Rated no-load running speed, pos. III | 0...2,500/min | 0...2,300/min | 0...2,500/min | 0...2,300/min |
| Impact speed | Max. 3,100/min | Max. 3,400/min | Max. 3,450/min | Max. 3,500/min |
| Speed adjustment | Three settings | Three settings | Three settings | Three settings |
| Standard screws | M8 - M16 | M8 - M16 | M8 - M16 | M8 - M16 |
| High-strength screws | M6 - M12 | M6 - M12 | M6 - M12 | M6 - M12 |
| Chuck | 1/4" hex. socket with locking sleeve | 1/2" square drive with ball-notch retention and 3/8" with locking ring | 1/4" hex. socket with locking sleeve | 1/2" square drive with ball-notch retention and 3/8" with locking ring |
| Speed control | Electronic, by way of the control switch | Electronic, by way of the control switch | Electronic, by way of the control switch | Electronic, by way of the control switch |
| Forward / reverse | Electronic switch with interlock to prevent switching while running | Electronic switch with interlock to prevent switching while running | Electronic switch with interlock to prevent switching while running | Electronic switch with interlock to prevent switching while running |
| Deep discharge protection | Yes | Yes | Yes | Yes |

NOTE

The torque selector switch can be used to select three torque settings.

| Power tool | Position I | Position II | Position III |
|------------------------------|------------------|-------------------|--------------------|
| SID 14-A | 50 Nm (37 lb/ft) | 100 Nm (74 lb/ft) | 150 Nm (111 lb/ft) |
| SIW 14-A (3/8" square drive) | 65 Nm (48 lb/ft) | 115 Nm (85 lb/ft) | 160 Nm (118 lb/ft) |
| SIW 14-A (1/2" square drive) | 80 Nm (59 lb/ft) | 120 Nm (89 lb/ft) | 185 Nm (136 lb/ft) |

| Power tool | Position I | Position II | Position III |
|------------------------------|------------------|--------------------|--------------------|
| SID 18-A | 60 Nm (44 lb/ft) | 110 Nm (81 lb/ft) | 165 Nm (122 lb/ft) |
| SIW 18-A (3/8" square drive) | 75 Nm (55 lb/ft) | 120 Nm (89 lb/ft) | 175 Nm (129 lb/ft) |
| SIW 18-A (1/2" square drive) | 90 Nm (66 lb/ft) | 135 Nm (100 lb/ft) | 200 Nm (148 lb/ft) |

| Battery | B 14/1.6 | B 14/3.3 | B 18/1.6 | B 18/2.6 | B 18/3.3 |
|------------------------|-------------------|-------------------|-------------------|-------------------|-------------------|
| Rated voltage | 14.4 V | 14.4 V | 21.6 V | 21.6 V | 21.6 V |
| Battery capacity | 1.6 Ah | 3.3 Ah | 1.6 Ah | 2.6 Ah | 3.3 Ah |
| Energy content | 23.04 Wh | 47.52 Wh | 34.56 Wh | 56.16 Wh | 71.28 Wh |
| Weight | 0.36 kg (0.79 lb) | 0.58 kg (1.28 lb) | 0.48 kg (1.06 lb) | 0.78 kg (1.72 lb) | 0.78 kg (1.72 lb) |
| Temperature monitoring | Yes | Yes | Yes | Yes | Yes |
| Type of cell | Lithium-ion | Lithium-ion | Lithium-ion | Lithium-ion | Lithium-ion |
| No. of cells | 4 | 8 | 6 | 12 | 12 |

5. Safety instructions

NOTE

The safety rules in section 5.1 contain all general safety rules for power tools which, in accordance with the applicable standards, require to be listed in the operating instructions. Accordingly, some of the rules listed may not be relevant to this tool.

5.1 General power tool safety warnings

a) WARNING

Read all safety warnings and instructions. Failure to follow the warnings and instructions may result in electric shock, fire and/or serious injury. **Save all warnings and instructions for future reference.** The term “power tool” in the warnings refers to your mains-operated (corded) power tool or battery-operated (cordless) power tool.

5.1.1 Work area safety

- Keep work area clean and well lit.** Cluttered or dark areas invite accidents.
- Do not operate power tools in explosive atmospheres, such as in the presence of flammable liquids, gases or dust.** Power tools create sparks which may ignite the dust or fumes.

- Keep children and bystanders away while operating a power tool.** Distractions can cause you to lose control.

5.1.2 Electrical safety

- Power tool plugs must match the outlet. Never modify the plug in any way. Do not use any adapter plugs with earthed (grounded) power tools.** Unmodified plugs and matching outlets will reduce risk of electric shock.
- Avoid body contact with earthed or grounded surfaces such as pipes, radiators, ranges and refrigerators.** There is an increased risk of electric shock if your body is earthed or grounded.
- Do not expose power tools to rain or wet conditions.** Water entering a power tool will increase the risk of electric shock.
- Do not abuse the cord. Never use the cord for carrying, pulling or unplugging the power tool. Keep cord away from heat, oil, sharp edges or moving parts.** Damaged or entangled cords increase the risk of electric shock.
- When operating a power tool outdoors, use an extension cord suitable for outdoor use.** Use of

a cord suitable for outdoor use reduces the risk of electric shock.

- f) **If operating a power tool in a damp location is unavoidable, use a residual current device (RCD) protected supply.** Use of an RCD reduces the risk of electric shock.

en

5.1.3 Personal safety

- a) **Stay alert, watch what you are doing and use common sense when operating a power tool. Do not use a power tool while you are tired or under the influence of drugs, alcohol or medication.** A moment of inattention while operating power tools may result in serious personal injury.
- b) **Use personal protective equipment. Always wear eye protection.** Protective equipment such as dust mask, non-skid safety shoes, hard hat, or hearing protection used for appropriate conditions will reduce personal injuries.
- c) **Prevent unintentional starting. Ensure the switch is in the off-position before connecting to power source and/or battery pack, picking up or carrying the tool.** Carrying power tools with your finger on the switch or energising power tools that have the switch on invites accidents.
- d) **Remove any adjusting key or wrench before turning the power tool on.** A wrench or a key left attached to a rotating part of the power tool may result in personal injury.
- e) **Do not overreach. Keep proper footing and balance at all times.** This enables better control of the power tool in unexpected situations.
- f) **Dress properly. Do not wear loose clothing or jewellery. Keep your hair, clothing and gloves away from moving parts.** Loose clothes, jewellery or long hair can be caught in moving parts.
- g) **If devices are provided for the connection of dust extraction and collection facilities, ensure these are connected and properly used.** Use of dust collection can reduce dust-related hazards.

5.1.4 Power tool use and care

- a) **Do not force the power tool. Use the correct power tool for your application.** The correct power tool will do the job better and safer at the rate for which it was designed.
- b) **Do not use the power tool if the switch does not turn it on and off.** Any power tool that cannot be controlled with the switch is dangerous and must be repaired.

- c) **Disconnect the plug from the power source and/or the battery pack from the power tool before making any adjustments, changing accessories, or storing power tools.** Such preventive safety measures reduce the risk of starting the power tool accidentally.
- d) **Store idle power tools out of the reach of children and do not allow persons unfamiliar with the power tool or these instructions to operate the power tool.** Power tools are dangerous in the hands of untrained users.
- e) **Maintain power tools. Check for misalignment or binding of moving parts, breakage of parts and any other condition that may affect the power tool's operation. If damaged, have the power tool repaired before use.** Many accidents are caused by poorly maintained power tools.
- f) **Keep cutting tools sharp and clean.** Properly maintained cutting tools with sharp cutting edges are less likely to bind and are easier to control.
- g) **Use the power tool, accessories and tool bits etc. in accordance with these instructions taking into account the working conditions and the work to be performed.** Use of the power tool for operations different from those intended could result in a hazardous situation.

5.1.5 Battery tool use and care

- a) **Recharge only with the charger specified by the manufacturer.** A charger that is suitable for one type of battery pack may create a risk of fire when used with another battery pack.
- b) **Use power tools only with specifically designated battery packs.** Use of any other battery packs may create a risk of injury and fire.
- c) **When battery pack is not in use, keep it away from other metal objects, like paper clips, coins, keys, nails, screws or other small metal objects, that can make a connection from one terminal to another.** Shorting the battery terminals together may cause burns or a fire.
- d) **Under abusive conditions, liquid may be ejected from the battery, avoid contact. If contact accidentally occurs, flush with water. If liquid contacts eyes, additionally seek medical help.** Liquid ejected from the battery may cause irritation or burns.

5.1.6 Service

- a) **Have your power tool serviced by a qualified repair person using only identical replacement parts.** This will ensure that the safety of the power tool is maintained.

5.2 Additional safety precautions

5.2.1 Personal safety

- a) **Hold power tool by insulated gripping surfaces, when performing an operation where the fastener may contact hidden wiring.** Fasteners contacting a "live" wire may make exposed metal parts of the power tool "live" and could give the operator an electric shock.
- b) **Wear ear protectors.** Exposure to noise can cause hearing loss.
- c) **Use auxiliary handle(s), if supplied with the tool.** Loss of control can cause personal injury.
- d) **Breathing protection must be worn if the power tool is used without a dust removal system for work that creates dust.**
- e) **Improve the blood circulation in your fingers by relaxing your hands and exercising your fingers during breaks between working.**
- f) **Avoid touching rotating parts. Switch the power tool on only after bringing it into position at the workpiece.** Touching rotating parts, especially rotating insert tools, may lead to injury.
- g) **Activate the safety lock (forward / reverse switch in the middle position) before storing or transporting the power tool.**
- h) **Children must be instructed not to play with the power tool.**
- i) **The power tool is not intended for use by children, by debilitated persons or those who have received no instruction or training.**
- j) **WARNING: Some dust created by grinding, sanding, cutting and drilling contains chemicals known to cause cancer, birth defects, infertility or other reproductive harm; or serious and permanent respiratory or other injury.** Some examples of these chemicals are: lead from lead-based paints, crystalline silica from bricks, concrete and other masonry products and natural stone, arsenic and chromium from chemically-treated lumber. Your risk from these exposures varies, depending on how often you do this type of work. **To reduce exposure to these chemicals, the operator and bystanders should work in a well-ventilated area, work with approved safety**

equipment, such as respiratory protection appropriate for the type of dust generated, and designed to filter out microscopic particles and direct dust away from the face and body. **Avoid prolonged contact with dust. Wear protective clothing and wash exposed areas with soap and water.** Allowing dust to get into your mouth, eyes, or to remain on your skin may promote absorption of harmful chemicals.

en

5.2.2 Power tool use and care

- a) **Secure the workpiece. Use clamps or a vice to secure the workpiece.** The workpiece is thus held more securely than by hand and both hands remain free to operate the power tool.
- b) **Check that the insert tools used are compatible with the chuck system and that they are secured in the chuck correctly.**
- c) **Ensure fastener and attachment will withstand the level of torque generated by the tool.** Excessive torque may overstress, strip or damage the fastener/attachment and possibly lead to personal injury.

5.2.3 Cordless tool use and care

- a) **Ensure the switch is in the off position before inserting the battery pack.** Inserting the battery pack into a lamp that is switched on may dazzle you.
- b) **Do not expose batteries to high temperatures or fire.** This presents a risk of explosion.
- c) **Do not disassemble, squash or incinerate batteries and do not subject them to temperatures over 80°C.** A risk of fire, explosion or injury through contact with caustic substances may otherwise result.
- d) **Avoid ingress of dampness.** Dampness may cause a short circuit resulting in a risk of burning injury or fire.
- e) **Do not use batteries other than those approved for use with the applicable power tool or appliance.** Use of other batteries or use of the battery for purposes for which it is not intended presents a risk of fire and explosion.
- f) **Observe the special instructions applicable to the transport, storage and use of Li-ion batteries.**
- g) **Remove the battery before storing or transporting the power tool.**
- h) **Avoid short-circuiting the battery. Check that the terminals on the battery and in the power tool**

are free from foreign objects before inserting the battery in the power tool. Short circuiting the battery terminals presents a risk of fire, explosion and chemical burns.

- i) **Do not charge or continue to use damaged batteries (e.g. batteries with cracks, broken parts, bent or pushed-in and/or pulled-out contacts).**
- j) If the battery gets too hot to touch, this may indicate that it is faulty. **Place the tool at a location where there is no risk of causing a fire (at least 3 meters away from flammable materials), where it can be kept under observation and allowed to cool. Contact Hilti Service after the battery has been allowed to cool.**

5.2.4 Electrical safety



Before beginning work, check the working area (e.g. using a metal detector) to ensure that no concealed electric cables or gas and water pipes

are present. External metal parts of the power tool may become live, for example, when an electric cable is damaged accidentally. This presents a serious risk of electric shock.

5.2.5 Work area

- a) **Ensure that the workplace is well lit.**
- b) **Ensure that the workplace is well ventilated.** Exposure to dust at a poorly ventilated workplace may result in damage to the health.

5.2.6 Personal protective equipment



The user and any other persons in the vicinity must wear ANSI Z87.1-approved eye protection, a hard hat, ear protection, protective gloves and breathing protection while the machine is in use.

6. Before use



6.1 Battery use and care

NOTE

Battery performance drops at low temperatures. Use the tool only after fully charging the battery. This ensures that maximum battery capacity is available. Change to a second battery as soon as a drop in performance is noticed. Recharge the battery immediately so that it is ready for reuse.

Store the battery in a cool, dry place. Never store the battery where it is exposed to direct sunlight or sources of heat, e.g. on heaters / radiators or behind a motor vehicle windscreen. Batteries that have reached the end of their life must be disposed of safely and correctly to avoid environmental pollution.

6.2 Charging the battery



DANGER

Only used the specified Hilti battery packs and Hilti battery chargers which are listed under "Accessories".

6.2.1 Charging a new battery for the first time

Charge the battery fully before using it for the first time.

6.2.2 Charging a previously used battery

Ensure that the outer surfaces of the battery are clean and dry before inserting it in the corresponding charger.

Read the operating instructions for the charger for further information about the charging procedure. Lithium-ion battery packs are ready to use at any time, even when only partially charged. Charging progress is indicated by the LED display (see charger operating instructions).

6.3 Fitting the battery

CAUTION

Before fitting the battery, check that the power tool is switched off and that the safety lock is engaged (forward/reverse switch in the middle position). Use only the Hilti batteries approved for use with this power tool.

CAUTION

Check that the terminals on the battery and in the power tool are free from foreign objects before inserting the battery in the power tool.

1. Push the battery into the power tool from the rear as far as it will go and until it is heard to engage with a double click.

2. **CAUTION If it is not fitted securely, the battery could fall out while you are working with the tool.**

CAUTION A falling battery may present a risk of injury to yourself or others.

Before beginning the work, check that the battery is fitted securely to the tool.

en

6.4 Removing the battery 2

1. Press one or both release buttons.
2. Pull the battery out of the power tool toward the rear.

6.5 Transport and storage of battery packs

Pull the battery pack out of the locked position (working position) and move it into the first latching position (transport position).

If you disconnect a battery pack from the power tool for transport or storage, make sure that the contacts of the battery pack are not short-circuited. Remove loose metal parts such as screws, nails, clamps, loose screw bits, wires or metal swarf from the case, toolbox or transport container, or prevent these parts from coming into contact with the battery packs.

Observe national and international transport regulations when shipping battery packs (transportation by road, rail, sea or air).

7. Operation

7.1 Changing insert tools

CAUTION

Wear protective gloves when changing insert tools as the insert tools get hot during use.

Check that the connection end of the insert tool is clean. Clean the connection end if necessary.

7.1.1 Changing insert tools with the SID 14-A and SID 18-A 3

NOTE

The power tool is equipped with a 1/4" hex. socket chuck with locking ring.

7.1.1.1 Fitting the screwdriving bit

1. Set the forward / reverse switch to the middle position or remove the battery from the power tool.

2. Push the bit into the chuck as far as it will go (until it engages).

NOTE Alternatively, pull the ring on the chuck forward. Hold it securely in this position and then push the bit into the chuck as far as it will go before releasing the ring.

7.1.1.2 Removing the screwdriving bit

1. Set the forward / reverse switch to the middle position or remove the battery from the power tool.
2. Pull the locking ring on the chuck forward and hold it in this position.
3. Pull the screwdriving bit out of the chuck and then release the locking ring.

7.1.2 Changing insert tools with the SIW 14-A and SIW 18-A **4**

NOTE

The power tool is equipped with two different chucks: $\frac{1}{2}$ " square drive with ball-notch retention or $\frac{3}{8}$ " with locking ring

en

7.1.2.1 Fitting the socket

1. Set the forward / reverse switch to the middle position or remove the battery from the power tool.
2. Align the hole in the side of the socket with the retention ball on the square drive.
3. Push the socket onto the square drive until it engages.

7.1.2.2 Removing the socket

1. Set the forward / reverse switch to the middle position or remove the battery from the power tool.
2. Through the round hole in the side of the socket, press the retention ball into the square drive.
3. Pull the socket off the square drive.

7.2 Setting forward or reverse rotation **5**

NOTE

The forward / reverse switch is used to select the direction of rotation of the drive spindle. An interlock prevents switching while the motor is running. The control switch is locked when the forward / reverse switch is in the middle position. Push the forward / reverse switch to the right (as seen in the working direction) for forward rotation. Push the forward / reverse switch to the left (as seen in the working direction) for reverse rotation.

NOTE

The power tool's working light is no substitute for good general illumination of the working area.

7.3 Torque selector switch **6**

The torque selector switch can be used to set the torque to one of three settings (see Technical Data section).

Slide the switch to the desired torque setting.

7.4 Switching on / off

The speed of the power tool can be controlled smoothly (increased from minimum to maximum) by pressing the control switch gradually.

7.5 Driving screws and tightening bolts

7.5.1 Fitting the bit / bit holder

1. Set the forward / reverse switch to the middle position or remove the battery from the power tool.
2. Fit the appropriate insert tool in the chuck.

7.5.2 Screwdriving

WARNING

Ensure fastener and attachment will withstand the level of torque generated by the tool. Excessive torque may overstress, strip or damage the fastener/attachment and possibly lead to personal injury.

1. Set the forward / reverse switch to the desired direction of rotation.
2. Set the torque selector switch to the desired torque.

7.6 Reading the charge status LED display on Li-ion batteries **7**

NOTE

The charge status cannot be indicated while the power tool is in operation. Indication is given (LED 1 blinks) only when the battery is fully discharged or when it is too hot (temperature above 80°C).

The Li-ion battery features a charge status LED display. The charge status is indicated by the LEDs on the battery during charging (please refer to the section "Li-ion battery charge status"). When the battery is at rest (not in use), its charge status is indicated by the four LEDs on the battery for a time of three seconds after pressing one of the battery release buttons.

7.7 Belt hook **8**

CAUTION

Check that the belt hook is fitted securely before beginning work.

The belt hook allows the power tool to be attached to a belt worn by the operator. The belt hook can also be fitted to the other side of the power tool for use by left-handed persons.

1. Pull the battery out of the tool.
2. Fit the mounting plate into the guides provided.
3. Secure the belt hook with the two screws.

8. Care and maintenance

CAUTION

Before beginning cleaning, remove the battery from the power tool in order to prevent unintentional starting.

8.1 Care of insert tools

Clean off dirt and dust deposits adhering to the insert tools and protect them from corrosion by wiping the insert tools from time to time with an oil-soaked rag.

8.2 Care of the power tool

CAUTION

Keep the power tool, especially its grip surfaces, clean and free from oil and grease. Do not use cleaning agents which contain silicone.

The outer casing of the power tool is made from impact-resistant plastic. Sections of the grip are made from a synthetic rubber material.

Never operate the power tool when the ventilation slots are blocked. Clean the ventilation slots carefully using a dry brush. Do not permit foreign objects to enter the interior of the power tool. Clean the outside of the power tool at regular intervals with a slightly damp cloth. Do not use a spray, steam pressure cleaning equipment or running water for cleaning. This may negatively affect the electrical safety of the power tool.

8.3 Maintenance

WARNING

Repairs to the electrical section of the power tool may be carried out only by trained electrical specialists.

Check all external parts of the power tool for damage at regular intervals and check that all controls operate faultlessly. Do not operate the power tool if parts are damaged or when the controls do not function

faultlessly. If necessary, the power tool should be repaired by Hilti Service.

8.4 Care of the Li-ion battery

Avoid entrance of moisture.

Charge the battery fully before using it for the first time.

In order to achieve maximum battery life, stop discharging the battery as soon as a significant drop in performance is noticed.

NOTE

If use of the power tool continues, further battery discharge will be stopped automatically before the battery cells suffer damage.

Charge the battery with the Hilti charger approved for use with Li-ion batteries.

NOTE

- A conditioning charge (as is required with NiCd or NiMH batteries) is not necessary.

- Interruption of the charging procedure has no negative effect on battery life.

- Charging can be started at any time with no negative effect on battery life. There is no memory effect (as with NiCd or NiMH batteries).

- For best results, batteries should be stored fully charged in a cool dry place. Avoid charging the battery in places subject to high ambient temperatures (e.g. at a window) as this has an adverse effect on battery life and increases the rate of self-discharge.

- If the battery no longer reaches full charge, it may have lost capacity due to aging or overstraining. It is possible to continue working with a battery in this condition but it should be replaced in good time.

8.5 Checking the power tool after care and maintenance

After carrying out care and maintenance work on the power tool, check that all protective and safety devices are fitted and that they function faultlessly.

en

9. Troubleshooting

en

| Fault | Possible cause | Remedy |
|--|--|--|
| The power tool doesn't run. | The battery is discharged or fitted incorrectly. | The battery must be heard to engage with a double click or, respectively, needs to be charged. |
| | Electrical fault. | Remove the battery from the power tool and contact Hilti Service. |
| The on / off switch can't be pressed, i.e. the switch is locked. | The forward / reverse switch is in the middle position (transport lock engaged). | Push the forward / reverse switch to the left or right. |
| Running speed suddenly drops considerably. | The battery is discharged. | Change the battery and recharge the discharged battery. |
| The battery runs down more quickly than usual. | Battery condition is not optimal. | Have battery condition diagnosed by Hilti Service or replace with a new battery. |
| The battery doesn't engage with an audible click. | The retaining lugs on the battery are dirty. | Clean the retaining lugs and check that the battery engages securely. Contact Hilti Service if the problem persists. |
| The power tool or the battery become very warm. | Electrical fault. | Switch the power tool off immediately, remove the battery and contact Hilti Service. |
| | The power tool has been overloaded (application limits exceeded). | Use the right power tool for the job (don't use a low-powered tool for heavy work). |

10. Disposal

CAUTION

Improper disposal of the equipment may have serious consequences: The burning of plastic components generates toxic fumes which may present a health hazard. Batteries may explode if damaged or exposed to very high temperatures, causing poisoning, burns, acid burns or environmental pollution. Careless disposal may permit unauthorized and improper use of the equipment. This may result in serious personal injury, injury to third parties and pollution of the environment.

CAUTION

Dispose of defective batteries without delay. Keep them out of reach of children. Do not attempt to open or dismantle batteries and do not dispose of them by incineration.

CAUTION

Dispose of the batteries in accordance with national regulations or return them to Hilti.



Most of the materials from which Hilti power tools or appliances are manufactured can be recycled. The materials must be correctly separated before they can be recycled. In many countries, Hilti has already made arrangements for taking back your old power tools or appliances for recycling. Please ask your Hilti customer service department or Hilti representative for further information.

en

11. Manufacturer's warranty - tools

Hilti warrants that the tool supplied is free of defects in material and workmanship. This warranty is valid so long as the tool is operated and handled correctly, cleaned and serviced properly and in accordance with the Hilti Operating Instructions, and the technical system is maintained. This means that only original Hilti consumables, components and spare parts may be used in the tool.

This warranty provides the free-of-charge repair or replacement of defective parts only over the entire lifespan of the tool. Parts requiring repair or replacement as a result of normal wear and tear are not covered by this warranty.

Additional claims are excluded, unless stringent national rules prohibit such exclusion. In particular, Hilti is not obligated for direct, indirect, incidental or consequential damages, losses or expenses in connection with, or by reason of, the use of, or inability to use the tool for any purpose. Implied warranties of merchantability or fitness for a particular purpose are specifically excluded.

For repair or replacement, send the tool or related parts immediately upon discovery of the defect to the address of the local Hilti marketing organization provided.

This constitutes Hilti's entire obligation with regard to warranty and supersedes all prior or contemporaneous comments and oral or written agreements concerning warranties.

HILTI

Hilti Corporation

LI-9494 Schaan

Tel.: +423 / 234 21 11

Fax: +423 / 234 29 65

www.hilti.com

Hilti = registered trademark of Hilti Corp., Schaan
W 3984 0711 00-Pos. 3 1 Printed in China © 2011
Right of technical and programme changes reserved S. E. & O.

2012668 / C

