



User Manual

Read and understand this manual before using machine.

10" GRANITE CABINET SAW



Model Number
35971/35972/36963/35964

(User can option 30" & 50" Rail with Fence and Mobile base)



THANK YOU for purchasing your new Steel City Cabinet Saw. This cabinet saw has been designed, tested, and inspected with you, the customer, in mind. When properly used and maintained, your cabinet saw will provide you with years of trouble free service, which is why it is backed by one of the longest machinery warranties in the business.

This cabinet saw is just one of many products in the Steel City's family of woodworking machinery and is proof of our commitment to total customer satisfaction.

At Steel City we continue to strive for excellence each and every day and value the opinion of you, our customer. For comments about your cabinet saw or Steel City Tool Works, please visit our web site at www.steelcitytoolworks.com.

TABLE OF CONTENTS

INTRODUCTION

SECTION 1	Warranty	4
SECTION 2	Product Specifications	7
SECTION 3	Accessories and Attachments	8
SECTION 4	Definition of Terms	8
SECTION 5	Feature Identification	9
SECTION 6	General Safety	10
SECTION 7	Product Safety	12
SECTION 8	Electrical Requirements	13
SECTION 9	Rounding Instructions	14
SECTION 10	Unpacking & Inventory	15
SECTION 11	Assembly	17
SECTION 12	Adjustments	23
SECTION 13	Operations	28
SECTION 14	Maintenance	32
SECTION 15	Troubleshooting Guide	34
SECTION 16	Parts	35

INTRODUCTION

This user manual is intended for use by anyone working with this machine. It should be kept available for immediate reference so that all operations can be performed with maximum efficiency and safety. Do not attempt to perform maintenance or operate this machine until you have read and understand the information contained in this manual.

The drawings, illustrations, photographs, and specifications in this user manual represent your machine at time of print. However, changes may be made to your machine or this manual at any time with no obligation to Steel City Tool Works

WARRANTY

STEEL CITY TOOL WORKS 5 YEAR LIMITED WARRANTY

Steel City Tool Works, LLC (“SCTW”) warrants all “STEEL CITY TOOL WORKS” machinery to be free of defects in workmanship and materials for a period of 5 years from the date of the original retail purchase by the original owner. (Granite components are warranted for 10 years. Please inform SCTW within 30 days for any damages or defects on the Granite components found upon receipt of the products to qualify for the 10 year limited warranty. See the Granite warranty statement supplied with those products.) SCTW will repair or replace, at its expense and at its option, any SCTW machine, machine part, or machine accessory which in normal use has proven to be defective, provided that the customer returns the product, shipping prepaid, to an authorized service center with proof of purchase and provides SCTW with a reasonable opportunity to verify the alleged defect by inspection. Date code, which can be found on the original carton and machine body, must be provided to SCTW at the time of any warranty request made. This warranty does not apply to defects due directly or indirectly to misuse, abuse, negligence, accidents, or lack of maintenance, or to unauthorized repairs or alterations made or specifically authorized by anyone other than SCTW. Normal wear components are also excluded under this coverage. Every effort has been made to ensure that all SCTW machinery meets the highest quality and durability standards. We reserve the right to change specifications at any time due to our commitment to continuous improvement of the quality of our products.

EXCEPT AS SET FORTH ABOVE, SCTW MAKES NO EXPRESS OR IMPLIED REPRESENTATIONS OR WARRANTIES WITH RESPECT TO ITS MACHINERY, OR ITS CONDITION, MERCHANTABILITY, OR FITNESS FOR ANY PARTICULAR PURPOSE OR USE. SCTW FURNISHES THE ABOVE WARRANTIES IN LIEU OF ALL OTHER WARRANTIES, EXPRESS OR IMPLIED, INCLUDING THE WARRANTIES OF MERCHANTABILITY AND FITNESS FOR A PARTICULAR PURPOSE, WHICH ARE HEREBY SPECIFICALLY DISCLAIMED.

SCTW SHALL NOT BE LIABLE FOR ANY (A) SPECIAL, INDIRECT, INCIDENTAL, PUNITIVE OR CONSEQUENTIAL DAMAGES, INCLUDING WITHOUT LIMITATION LOSS OF PROFITS, ARISING FROM OR RELATED TO THIS WARRANTY, THE BREACH OF ANY AGREEMENT OR WARRANTY, OR THE OPERATION OR USE OF ITS MACHINERY, INCLUDING WITHOUT LIMITATION DAMAGES ARISING FROM DAMAGE TO FIXTURES, TOOLS, EQUIPMENT, PARTS OR MATERIALS, DIRECT OR INDIRECT LOSS CAUSED BY ANY OTHER PARTY, LOSS OF REVENUE OR PROFITS, FINANCING OR INTEREST CHARGES, AND CLAIMS BY ANY THIRD PERSON, WHETHER OR NOT NOTICE OF SUCH POSSIBLE DAMAGES HAS BEEN GIVEN TO SCTW; (B) DAMAGES OF ANY KIND FOR ANY DELAY BY OR FAILURE OF SCTW TO PERFORM ITS OBLIGATIONS UNDER THIS AGREEMENT; OR (C) CLAIMS MADE A SUBJECT OF A LEGAL PROCEEDING AGAINST SCTW MORE THAN ONE (1) YEAR AFTER SUCH CAUSE OF ACTION FIRST AROSE.

The validity, construction and performance of this Warranty and any sale of machinery by SCTW shall be governed by the laws of the Commonwealth of Pennsylvania, without regard to conflicts of laws provisions of any jurisdiction. Any action related in any way to any alleged or actual offer, acceptance or sale by SCTW, or any claim related to the performance of any agreement including without limitation this Warranty, shall take place in the federal or state courts in Allegheny County, Pennsylvania.

STEEL CITY TOOL WORKS

Tech Service
1-877-724-8665
Please have your Model No.
and Serial No. available

WARRANTY CARD

Name _____
 Street _____
 Apt. No. _____
 City _____ State _____ Zip _____
 Phone Number _____
 E-Mail _____

Product Description: _____
 Model No.: _____
 Serial No. _____

The following information is given on a voluntary basis and is strictly confidential.

1. Where did you purchase your STEEL CITY machine?
 Store: _____
 City: _____

2. How did you first learn of Steel City Tool Works?
 Advertisement Mail Order Catalog
 Web Site Friend
 Local Store Other _____

3. Which of the following magazines do you subscribe to?
 American Woodworker American How-To
 Cabinetmaker Family Handyman
 Fine Homebuilding Fine Woodworking
 Journal of Light Construction Old House Journal
 Popular Mechanics Popular Science
 Popular Woodworking Today's Homeowner
 WOOD Woodcraft
 WOODEN Boat Woodshop News
 Woodsmith Woodwork
 Woodworker Woodworker's Journal
 Workbench Other _____

4. Which of the following woodworking / remodeling shows do you watch?
 Backyard America The American Woodworker
 Home Time The New Yankee Workshop
 This Old House Woodwright's Shop
 Other _____

5. What is your annual household income?
 \$20,000 to \$29,999 \$30,000 to \$39,999
 \$40,000 to \$49,999 \$50,000 to \$59,999
 \$60,000 to \$69,999 70,000 to \$79,999
 \$80,000 to \$89,999 \$90,000 +

6. What is your age group?
 20 to 29 years 30 to 39 years
 40 to 49 years 50 to 59 years
 60 to 69 years 70 + years

7. How long have you been a woodworker?
 0 to 2 years 2 to 8 years
 8 to 20 years over 20 years

8. How would you rank your woodworking skills?
 Simple Intermediate
 Advance Master Craftsman

9. How many Steel City machines do you own? _____

10. What stationary woodworking tools do you own?
Check all that apply.
 Air Compressor Band Saw
 Drill Press Drum Sander
 Dust Collection Horizontal Boring Machine
 Jointer Lathe
 Mortiser Panel Saw
 Planer Power Feeder
 Radial Arm Saw Shaper
 Spindle Sander Table Saw
 Vacuum Veneer Press Wide Belt Sander
 Other _____

11. Which benchtop tools do you own? *Check all that apply.*
 Belt Sander Belt / Disc Sander
 Drill Press Band Saw
 Grinder Mini Jointer
 Mini Lathe Scroll Saw
 Spindle / Belt Sander Other _____

12. Which portable / hand held power tools do you own?
Check all that apply.
 Belt Sander Biscuit Jointer
 Dust Collector Circular Saw
 Detail Sander Drill / Driver
 Miter Saw Orbital Sander
 Palm Sander Portable Thickness Planer
 Saber Saw Reciprocating Saw
 Router Other _____

13. What machines / accessories would you like to see added to the STEEL CITY line?

14. What new accessories would you like to see added?

15. Do you think your purchase represents good value?
 Yes No

16. Would you recommend STEEL CITY products to a friend?
 Yes No

17. Comments:

CUT HERE

FOLD ON DOTTED LINE

PLACE
STAMP
HERE

Steel City Tool Works
3656 Enterprise Avenue
Hayward, CA 94545

FOLD ON DOTTED LINE

PRODUCT SPECIFICATIONS

Model No. 35964/35972

Motor	Induction	Number of Teeth	40
HP	3	Blade Speed	3450
Amps	13	Max Depth of Cut at 90°	3-3/8-in
Volts	240	Max Depth of Cut at 45	2-1/4-in
Hertz	60	Table in front of blade At max Depth of Cut	12-1/2-in
RPM	3450	Max Dado Width	13/16-in
Blade Tilt	Left	Max Dado Blade Diameter	8-in
Blade Drive	Poly-V Belt	Left Extension Wing for 35972	15.7-in Granite
Blade Diameter	10-in	Right Extension Wing for 35972	16.9-in Granite
Blade Arbor	5/8-in	Left Extension Wing for 35964	15.7-in Cast Iron
		Right Extension Wing for 35964	16.9-in Cast Iron

Model No. 35963/35971

Motor	Induction	Number of Teeth	40
HP	1.75	Blade Speed	3450
Amps	6.5	Max Depth of Cut at 90°	3-3/8-in
Volts	240	Max Depth of Cut at 45	2-1/4-in
Hertz	60	Table in front of blade At max Depth of Cut	12-1/2-in
RPM	3450	Max Dado Width	13/16-in
Blade Tilt	Left	Max Dado Blade Diameter	8-in
Blade Drive	Poly-V Belt	Left Extension Wing for 35971	15.7-in Granite
Blade Diameter	10-in	Right Extension Wing for 35971	16.9-in Granite
Blade Arbor	5/8-in	Left Extension Wing for 35963	15.7-in Cast Iron
		Right Extension Wing for 35963	16.9-in Cast Iron

Model No. 35971/35972/35963/35964

PRODUCT DIMENSIONS

Length	44"
Width	27"
Height	40.5"
Net Weight	407.8lb
Footprint	19.4"x22"

SHIPPING DIMENSIONS:

Length	35.4"
Width	30"
Height	42.3"
Gross Weight	458.5lb

ACCESSORIES AND ATTACHMENTS

There are a variety of accessories available for your Steel City Product. For more information on any accessories associated with this and other machines, please contact your nearest Steel City distributor, or visit our website at : www.steelcitytoolworks.com.

DEFINITION OF TERMS

Anti-Kickback Fingers – A safety device attached to the blade guard and splitter assembly designed to minimize the chance of a workpiece being thrown back during a cutting operation.

Arbor – The shaft on which the blade or accessory cutting-tool is mounted.

Bevel Cut – The operation of making any cut with the blade set at an angle other than 90 degrees.

Compound Cut – The operation of making both a bevel and a miter cut at one time.

Crosscut – The operation of making a cut across the grain or width of a workpiece.

Dado – A non-through cut that produces a square notch. A dado is typically from 1/8-in. to 13/16-in. wide. A dado requires a special set of blades, not included with this table saw.

Featherboard – An accessory device that can be made or purchased to help guide or hold down a workpiece during cutting operations.

Freehand – A very dangerous operation of making a cut without using the fence or miter gauge in a cutting operation. **FREEHAND CUTS MUST NEVER BE PERFORMED ON A TABLE SAW.**

Gum, Pitch or Resin – A sticky, sap based residue that comes from wood products.

Heeling – The misalignment of the blade to the miter slots; when the blade is not parallel to the miter slots.

Kerf – The material removed from the workpiece by the blade during any cutting operation.

Kickback – When the workpiece is thrown back toward the operator at a high rate of speed during a cutting operation.

Riving Knife-The same as splitter-it prevents the slot cut into kerf from closing behind the blade on a rip. Also the clearance between riving knife and blade will be consistent when raising or lowering blade.

Miter Cut – The operation of making a cut using the miter gauge at any angle other than zero degrees.

Push Stick – An accessory device that can be made or purchased to help push the workpiece through the blade. A push stick is used to keep the operator hands away from the blade when ripping a narrow workpiece.

Rabbet – A square notch in the edge of the workpiece.

Rip Cut – The operation of making a cut with the grain or down the length of the workpiece.

Saw Blade Path – The area that is directly in line with the blade, including area over, under, behind and in front of it.

Set of the Saw Blade – The distance that the tips of the saw blade are angled outwards from the thickness of the blade.

Table/Work Area – The total surface of the top of the table saw on which the workpiece rests while set-up or cutting operations are being performed.

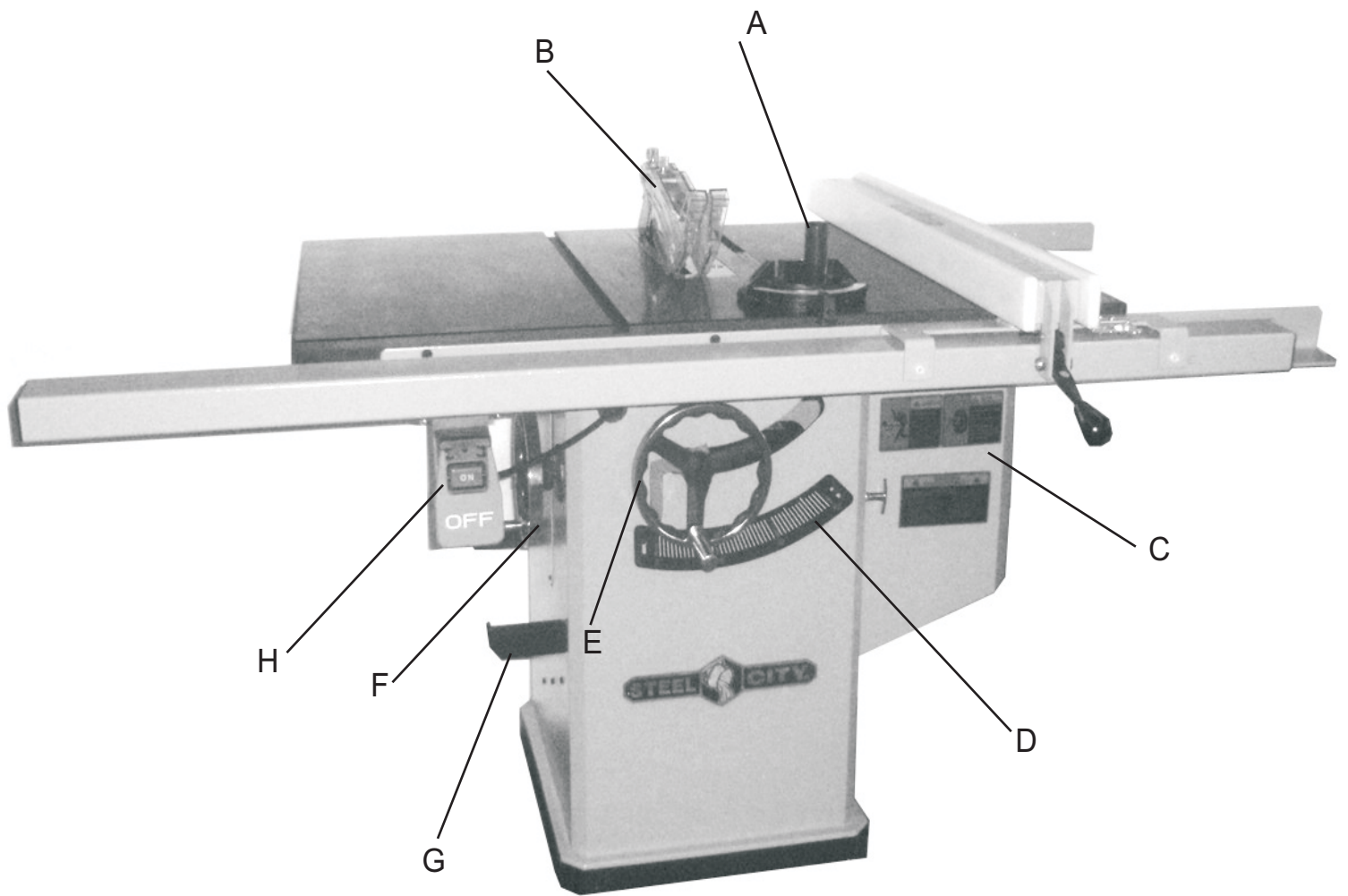

- A) Miter Gauge
- B) Blade Guard Assembly with riving knife
- C) Motor Cover
- D) Bevel Scale
- E) Height Adjustment Handwheel
- F) Bevel Adjustment Handwheel
- G) Fence Hooks(2)
- H) On/Off Switch

GENERAL SAFETY

WARNING

TO AVOID serious injury and damage to the machine, read and follow all Safety and Operating Instructions before assembling and operating this machine.

This manual is not totally comprehensive. It does not and can not convey every possible safety and operational problem which may arise while using this machine. The manual will cover many of the basic and specific safety procedures needed in an industrial environment.

All federal and state laws and any regulations having jurisdiction covering the safety requirements for use of this machine take precedence over the statements in this manual. Users of this machine must adhere to all such regulations.

Below is a list of symbols that are used to attract your attention to possible dangerous conditions.



This is the international safety alert symbol. It is used to alert you to potential personal injury hazards. Obey all safety messages that follow this symbol to avoid possible injury or death.

DANGER

Indicates an imminently hazardous situation which, if not avoided, **WILL** result in death or serious injury.

WARNING

Indicates a potentially hazardous situation which, if not avoided, **COULD** result in death or serious injury.

CAUTION

Indicates a potentially hazardous situation, if not avoided, **MAY** result in minor or moderate injury. It may also be used to alert against unsafe practices.

CAUTION

CAUTION used without the safety alert symbol indicates a potentially hazardous situation which, if not avoided, may result in property damage.

NOTICE

This symbol is used to alert the user to useful information about proper operation of the machine.

WARNING

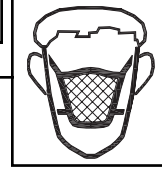

Exposure to the dust created by power sanding, sawing, grinding, drilling and other construction activities may cause serious and permanent respiratory or other injury, including silicosis (a serious lung disease), cancer, and death. Avoid breathing the dust, and avoid prolonged contact with dust. The dust may contain chemicals known to the State of California to cause cancer, birth defects or other reproductive harm.

Some examples of these chemicals are:

- Lead from lead-based paints.
- Crystalline silica from bricks, cement and other masonry products.
- Arsenic and chromium from chemically-treated lumber.

Always operate tool in well ventilated area and provide for proper dust removal. Use a dust collection system along with an air filtration system whenever possible. Always use properly fitting NIOSH/OSHA approved respiratory protection appropriate for the dust exposure, and wash exposed areas with soap and water.

1. To avoid serious injury and damage to the machine, read the entire User Manual before assembly and operation of this machine.

WARNING

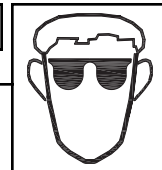

2. **ALWAYS** wear eye protection. Any machine can throw debris into the eyes during operations, which could cause severe and permanent eye damage. Everyday eyeglasses are **NOT** safety glasses. **ALWAYS** wear Safety Goggles (that comply with ANSI standard Z87.1) when operating power tools.

▲ WARNING

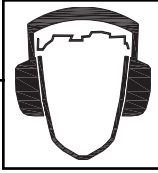

3. **ALWAYS** wear hearing protection. Plain cotton is not an acceptable protective device. Hearing equipment should comply with ANSI S3.19 Standards.

▲ WARNING

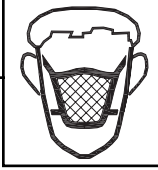

4. **ALWAYS** wear a NIOSH/OSHA approved dust mask to prevent inhaling dangerous dust or airborne particles.

5. **ALWAYS** keep the work area clean, well lit, and organized. **DO NOT** work in an area that has slippery floor surfaces from debris, grease, and wax.
6. **ALWAYS** unplug the machine from the electrical receptacle before making adjustments, changing parts or performing any maintenance.
7. **AVOID ACCIDENTAL STARTING.** Make sure that the power switch is in the "OFF" position before plugging in the power cord to the electrical receptacle.

▲ WARNING

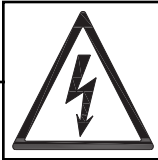

8. **AVOID** a dangerous working environment. **DO NOT** use electrical tools in a damp environment or expose them to rain or moisture.

▲ WARNING

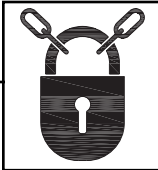

9. **CHILDPROOF THE WORKSHOP AREA** by removing switch keys, unplugging tools from the electrical receptacles, and using padlocks.

10. **DO NOT** use electrical tools in the presence of flammable liquids or gasses.

11. **DO NOT FORCE** the machine to perform an operation for which it was not designed. It will do a safer and higher quality job by only performing operations for which the machine was intended.
12. **DO NOT** stand on a machine. Serious injury could result if it tips over or you accidentally contact any moving part.
13. **DO NOT** store anything above or near the machine.
14. **DO NOT** operate any machine or tool if under the influence of drugs, alcohol, or medication.
15. **EACH AND EVERY** time, check for damaged parts prior to using any machine. Carefully check all guards to see that they operate properly, are not damaged, and perform their intended functions. Check for alignment, binding or breakage of all moving parts. Any guard or other part that is damaged should be immediately repaired or replaced.
16. Ground all machines. If any machine is supplied with a 3-prong plug, it must be plugged into a 3-contact electrical receptacle. The third prong is used to ground the tool and provide protection against accidental electric shock. **DO NOT** remove the third prong.
17. Keep visitors and children away from any machine. **DO NOT** permit people to be in the immediate work area, especially when the machine is operating.
18. **KEEP** protective guards in place and in working order.
19. **MAINTAIN** your balance. **DO NOT** extend yourself over the tool. Wear oil resistant rubber soled shoes. Keep floor clear of debris, grease, and wax.
20. **MAINTAIN** all machines with care. **ALWAYS KEEP** machine clean and in good working order. **KEEP** all blades and tool bits sharp.
21. **NEVER** leave a machine running, unattended. Turn the power switch to the OFF position. **DO NOT** leave the machine until it has come to a complete stop.
22. **REMOVE ALL MAINTENANCE TOOLS** from the immediate area prior to turning the machine ON.
23. **SECURE** all work. When it is possible, use clamps or jigs to secure the workpiece. This is safer than attempting to hold the workpiece with your hands.
24. **STAY ALERT**, watch what you are doing, and use common sense when operating any machine. **DO NOT** operate any machine tool while tired or under the influence of drugs, alcohol, or medication. A moment of inattention while operating power tools may result in serious personal injury.

25. **USE ONLY** recommended accessories. Use of incorrect or improper accessories could cause serious injury to the operator and cause damage to the machine. If in doubt, **DO NOT** use it.
26. Wear proper clothing, **DO NOT** wear loose clothing, gloves, neckties, or jewelry. These items can get caught in the machine during operations and pull the operator into the moving parts. Users must wear a protective cover on their hair, if the hair is long, to prevent it from contacting any moving parts.
28. **SAVE** these instructions and refer to them frequently and use them to instruct other users.

29. Information regarding the safe and proper operation of this tool is also available from the following sources:

Power Tool Institute
1300 Summer Avenue
Cleveland, OH 44115-2851 www.powertoolinstitute.org

National Safety Council
1121 Spring Lake Drive
Itasca, IL 60143-3201

American National Standards Institute
25 West 43rd. St, 4th Floor
New York, NY. 10036
ANSI 01.1 Safety Requirements
For Woodworking Machines
WWW.ANSI.ORG

U.S. Department of Labor Regulations
OSHA 1910.213 Regulations
WWW.OSHA.GOV

PRODUCT SAFETY

1. Serious personal injury may occur if normal safety precautions are overlooked or ignored. Accidents are frequently caused by lack of familiarity or failure to pay attention. Obtain advice from supervisor, instructor, or another qualified individual who is familiar with this machine and its operations.
2. Every work area is different. Always consider safety first, as it applies to your work area. Use this machine with respect and caution. Failure to do so could result in serious personal injury and damage to the machine.
3. Prevent electrical shock. Follow all electrical and safety codes, including the National Electrical Code (NEC) and the Occupational Safety and Health Regulations (OSHA). All electrical connections and Wiring should be made by qualified personnel only.

WARNING



4. **TO REDUCE** the risk of electrical shock. **DO NOT** use this machine outdoors. **DO NOT** expose to rain or moisture. Store indoors in a dry area.

5. STOP using this machine, if at any time you experience difficulties in performing any operation. Contact your supervisor, instructor or machine service Center immediately.

6. Safety decals are on this machine to warn and direct you to how to protect yourself or visitors from personal injury. These decals **MUST** be maintained so that they are legible. **REPLACE** decals that are not legible.
7. **DO NOT** leave the unit plugged into the electrical outlet. Unplug the unit from the outlet when not in use and before servicing, performing maintenance tasks, or cleaning.
8. **ALWAYS** turn the power switch "OFF" before Unplugging the table saw.

WARNING

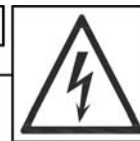

9. **DO NOT** handle the plug or table saw with wet hands.

10. **USE** accessories only recommended by Steel City.
11. **DO NOT** pull the table saw by the power cord. **NEVER** allow the power cord to come in contact with sharp edges, hot surfaces, oil or grease.
12. **DO NOT** unplug the table saw by pulling on the power cord. **ALWAYS** grasp the plug, not the cord.
13. **REPLACE** a damaged cord immediately. **DO NOT** use a damaged cord or plug. **DO NOT USE** if the table saw is not operating properly, or has been damaged, left outdoors or has been in contact with Water.

14. **DO NOT** use near or around children.
15. **ENSURE** that the machine sits firmly on the floor before using. If the machine wobbles or is unstable, correct the problem by using shims or blocks prior to operation.
16. **KEEP** saw blade sharp and clean. Failure to do so greatly increases friction, decreases cut quality, and increases the possibility of a kickback.
17. **MAKE CERTAIN** the saw blade is parallel with the miter slots and with the rip fence. A blade that is not aligned parallel can cause the workpiece to be pinched between the blade and the fence causing burning or kickbacks.
18. **ALWAYS** use blade guard on all through cuts. This will help prevent the cut from closing on the back of the saw blade. The blade guard also has anti-kickback fingers which minimize the chance of a workpiece being thrown back during a cutting operation.
19. **ALWAYS** push the workpiece past the blade.
DO NOT release a workpiece until it is past the blade and removed from the saw.
20. **DO NOT** execute a cut when you do not have complete control of the situation.
21. **DO NOT** cut a workpiece that is too large for you to safely handle. Use an out feed table or work stand to properly support the piece.
22. **DO NOT** use the rip fence as a guide cross cutting.
23. **BE MINDFUL** of flaws in the wood. Cutting a warped or twisted board along the rip fence can get pinched between the fence and the blade, causing a kickback.
24. **ALWAYS** remove cut off pieces and scraps from the table before starting the saw.
25. **NEVER** start the machine with the workpiece against the blade.
26. **NEVER** perform freehand operations. Use either the fence or miter gauge to position and guide the workpiece through the blade.
27. **ALWAYS** use a push stick for ripping narrow workpieces.
28. **NEVER** have any part of your body in line with the path of the saw blade. If a kickback occurs with you directly in front of the blade, a serious injury can occur.
29. **NEVER** attempt to free a stalled blade without first turning the machine off and disconnecting the saw from the power source.
30. **DO NOT** reach over or behind a rotating saw Blade

ELECTRICAL REQUIREMENTS

▲ WARNING



To reduce the risk of electric shock, follow all electrical and safety codes, including the National Electric Code (NEC) and the Occupational Safety and Health Regulations (OSHA). All electrical connections and wiring should be made by qualified personnel only.

The switch provided with your saw is a magnetic switch designed for 240 volt single phase usage only. The switch has a plug that is designed to plug into a 240 volt outlet. There are many different configurations for 240 volt outlets, so it is conceivable that the configuration of the plug may not match the configuration of your existing outlet. If this is the case, you will have to replace the plug with a UL/CSA approved plug that matches the configuration of your 240V outlet.

GROUNDING INSTRUCTIONS

⚠️ WARNING



This machine **MUST BE GROUNDED** while in use to protect the operator from electric shock.

In the event of a malfunction or breakdown, **GROUNDING** provides the path of least resistance for electric current and reduces the risk of electric shock. The plug **MUST** be plugged into a matching electrical receptacle that is properly installed and grounded in accordance With **ALL** local codes and ordinances.

If a plug is provided with your machine **DO NOT** modify the plug. If it will not fit your electrical receptacle, have a qualified electrician install the proper connections to meet all electrical codes local and state. All connections must also adhere to all of OSHA mandates.

IMPROPER ELECTRICAL CONNECTION of the equipment-grounding conductor can result in risk of electric shock. The conductor with the green insulation (with or without yellow stripes) is the equipment-grounding conductor. **DO NOT** connect the equipment-grounding conductor to a live

Check with a qualified electrician or service personnel if you do not completely understand the grounding instructions, or if you are not sure the tool is properly grounded.

PLUGS/RECEPTACLES

⚠️ WARNING



- Electrocutation or fire could result if this machine is not grounded properly or if the electrical configuration does not comply with local and state electrical codes.
- **MAKE CERTAIN** the machine is disconnected from power source before starting any electrical work.
- **MAKE SURE** the circuit breaker does not exceed the rating of the plug and receptacle.

The motor supplied with your machine is a dedicated 240 volt. Never connect the green or ground wire to a live terminal.

The machine should only be connected to an outlet having the same configuration as the plug.

EXTENSION CORDS

⚠️ WARNING



To reduce the risk of fire or electrical shock, use the proper gauge of extension cord. When using an extension cord, be sure to use one heavy enough to carry the current your machine will draw.

The smaller the gauge-number, the larger the diameter of the extension cord is. If in doubt of the proper size of an extension cord, use a shorter and thicker cord. An undersized cord will cause a drop in line voltage resulting in a loss of power and overheating.

⚠️ CAUTION

USE ONLY a 3-wire extension cord that has a 3-prong grounding plug and a 3-pole receptacle that accepts the machine's plug.

If you are using an extension cord outdoors, be sure it is marked with the suffix " W-A " ("W" in Canada) to indicate that it is acceptable for out door use.

Make certain the extension cord is properly sized, and in good electrical condition. Always replace a worn or damaged extension cord immediately or have it repaired by a qualified person before using it.

Protect your extension cords from sharp objects, excessive heat, and damp or wet areas.

MINIMUM RECOMMENDED GAUGE FOR EXTENSION CORDS (AWG)

240 VOLT OPERATION ONLY

	25' LONG	50' LONG	100' LONG
0 to 6 Amps	18 AWG	18 AWG	16 AWG
6 to 10 Amps	18 AWG	18 AWG	14 AWG
10 to 12 Amps	16 AWG	16 AWG	14 AWG
12 to 15 Amps	14 AWG	12 AWG	Not recommended

UNPACKING & INVENTORY

⚠️ WARNING



- The machine is heavy, two people are required to unpack and lift.
- Use a safety strap to avoid tip over when lifting machine.

Remove any protective materials and coatings from all of the parts and the table saw. The protective coatings can be removed by spraying WD-40. Do not use oil based products on Granite.

Check shipping carton and machine for damage before unpacking. Carefully remove packaging materials, parts and machine from shipping carton. Always check for and remove protective shipping materials around motors and moving parts. Lay out all parts on a clean

⚠️ WARNING

Parts can be cleaned by spraying WD-40 on them and wiping it off with a soft cloth. This may need redone several times before all of the protective coatings are removed completely. Do not use oil based products on Granite.

After cleaning, apply a good quality paste wax to any unpainted surfaces. Make sure to buff out the wax before assembly.

Compare the items to inventory figures; verify that all items are accounted for before discarding the shipping box.

If any parts are missing, do not attempt to plug in the power cord and turn "ON" the machine. The machine should only be turned "ON" after all the parts have been obtained and installed correctly. For missing parts, contact Steel City at 1-877-SC4-TOOL.

- A) Blade Guard and Splitter Assembly
- B) On/Off Switch
- C) Miter Gauge
- D) Blade Wrench
- E) Blade Wrench
- F) Handwheel Assembly(2)
- G) Handwheel Lock Knob(2)

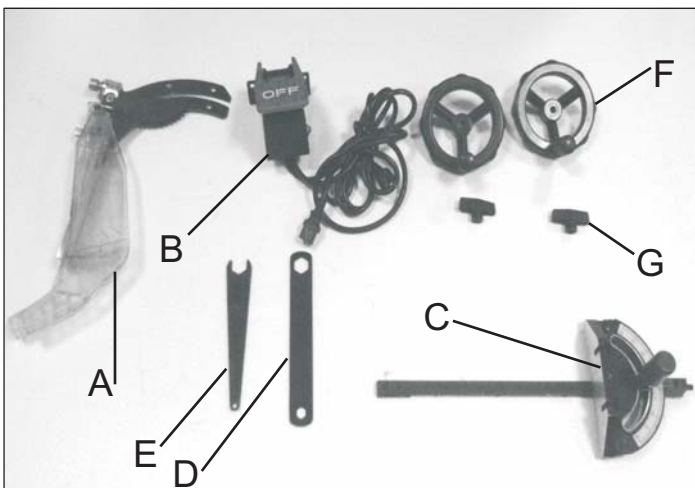

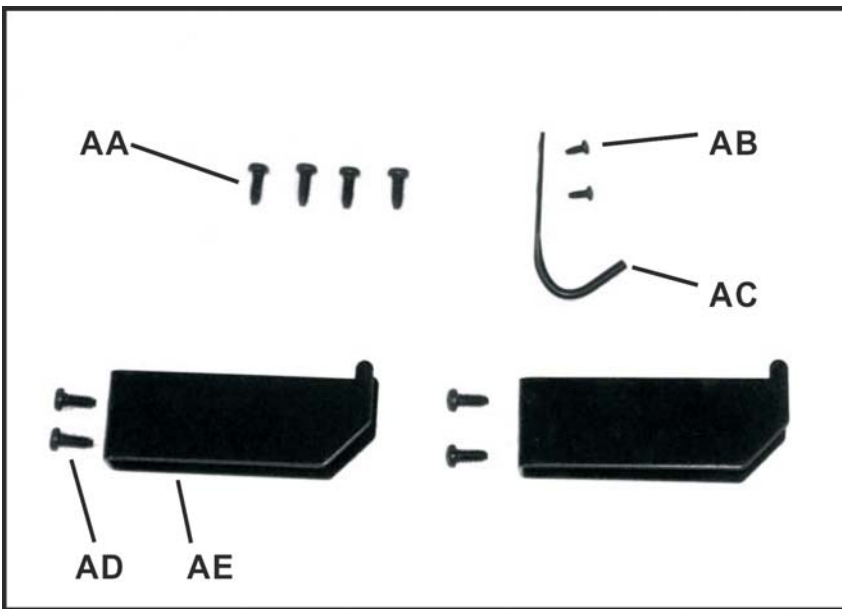

- AA) 1/4-20x1/2" ROUND HD TAP SCREW (4) for dust chute
- AB) M4x8mm ROUND HD TAP SCREW (2)
- AC) WRENCH HOOK
- AD) 1/4-20x3/8" ROUND HD TAP SCREW (4)
- AE) FENCE BRACKET (2)

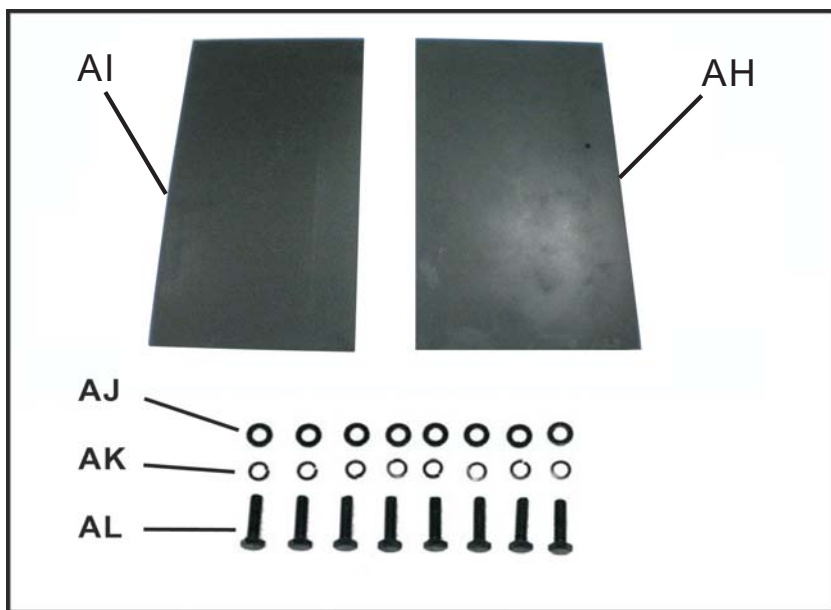

GRANITE EXTENSION WING FOR 35971/35972

- AH) RIGHT GRANITE EXTENSION WING
- AI) LEFT GRANITE EXTENSION WING
- AJ) M8 SPECIAL WASHER (8)
- AK) M8 LOCK WASHER (8)
- AL) 5/16-18X42mm HEX SOC SET BOLTS (8)

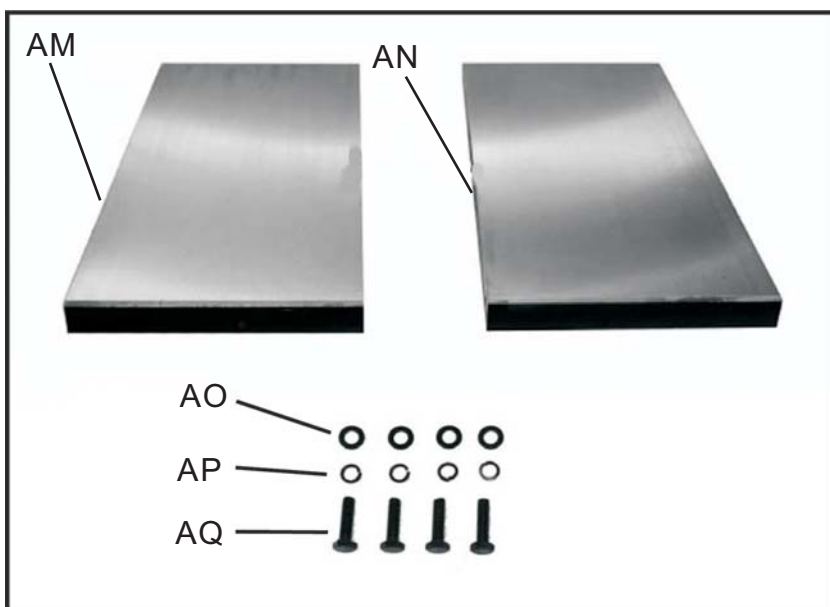

CAST IRON EXTENSION WING FOR 35963/35964

- AM) LEFT CAST IRON EXTENSION WING
- AN) RIGHT CAST IRON EXTENSION WING
- AO) M8 SPECIAL WASHER (4)
- AP) M8 LOCK WASHER (4)
- AQ) 5/16-18X42mm HEX SOC SET BOLTS (4)

ASSEMBLY

⚠ WARNING

- The table saw is a heavy machine; two people may be required for certain assembly operations.
- DO NOT assemble the table saw until you are sure the tool is unplugged.
- DO NOT assemble the table saw until you are sure the power switch is in the "OFF" position.
- For your own safety, DO NOT connect the machine to the power source until the machine is completely assembled and you read and understand this entire User Manual.

INSTALLATION AND LEVELING

Final location for the saw must be level, dry, well lighted, and have enough room to allow movement around the saw with long pieces of wood stock.

Level the saw front to back and side to side. If necessary, but make sure the saw is stable before being placed in to service.

DUST PORT ASSEMBLY

⚠ WARNING

MAKE CERTAIN THAT THE SAW IS DISCONNECTED FROM THE POWER SOURCE.

Fig. 1



1. Attach the dust port to the opening in the bottom rear of the cabinet with four 1/4-20x1/2" **SEE FIG.1.**

HANDWHEEL ASSEMBLY

⚠ WARNING

MAKE CERTAIN THAT THE SAW IS DISCONNECTED FROM THE POWER SOURCE.

Fig. 2

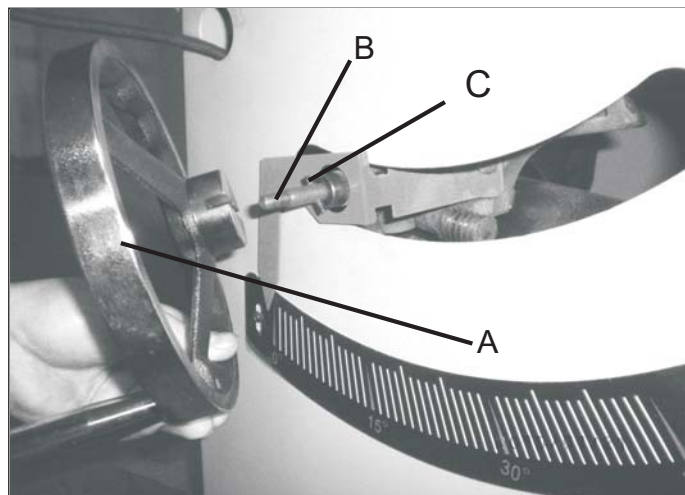

1. Place one of the handwheels (A) onto the blade raise/lower shaft (B) located on the front of the cabinet. Align the groove in the back of the handwheel with the pin (C). **SEE FIG 2.**

Fig. 3

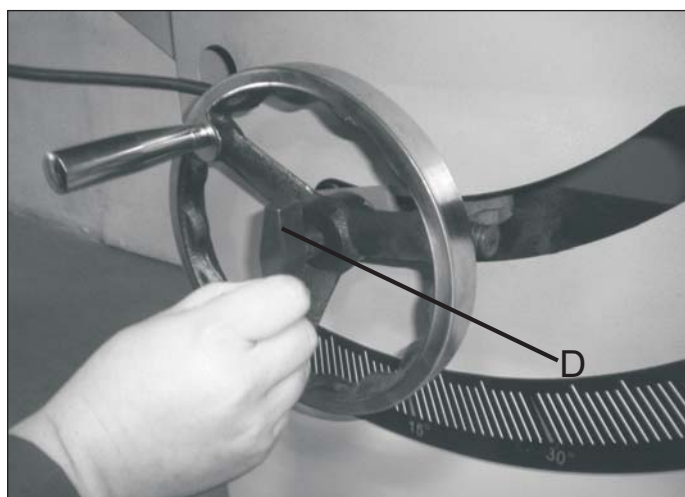

2. Thread the locking knob (D) onto the threaded end of the shaft. **SEE FIG 3.**
3. Repeat the steps above to assemble the remaining handwheel and locking knob onto the bevel shaft located on the side of the cabinet.

WRENCH AND FENCE HOOK ASSEMBLY

▲WARNING

MAKE CERTAIN THAT THE SAW IS DISCONNECTED FROM THE POWER SOURCE.

Fig. 4

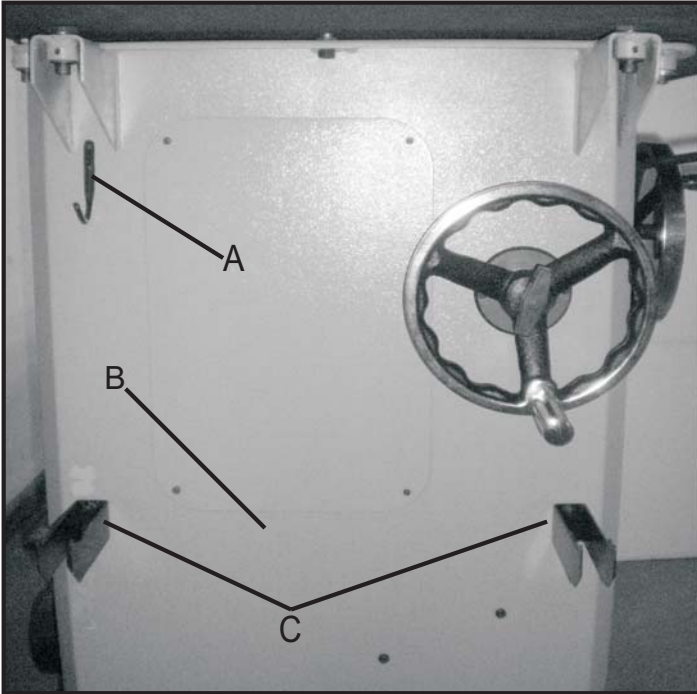

1. Assemble both of the fence hooks (A) to the left side of the cabinet (B) using four 1/4-20x3/8" (4) round head screws.
2. Assemble wrench hook (C) to the left side of cabinet (B) using (2) 1/4-20x3/8" round head screws.
SEE FIG 4.

POLY-V BELT ASSEMBLY

▲WARNING

MAKE CERTAIN THAT THE SAW IS DISCONNECTED FROM THE POWER SOURCE.

1. Loosen 4 of M4x8mm pan head tap screws (D) and remove the cabinet access door. **SEE FIG 5.**
2. Install the belt on the Arbor Pulley and raise motor by loosening 2 of the motor mounting screws (A) to reach the belt distance for assembling the belt on the motor Pully.
3. Using a straight edge, check both pulleys to make sure they are parallel. **SEE FIG 6.**
4. Replace the cabinet access door.

Fig. 5

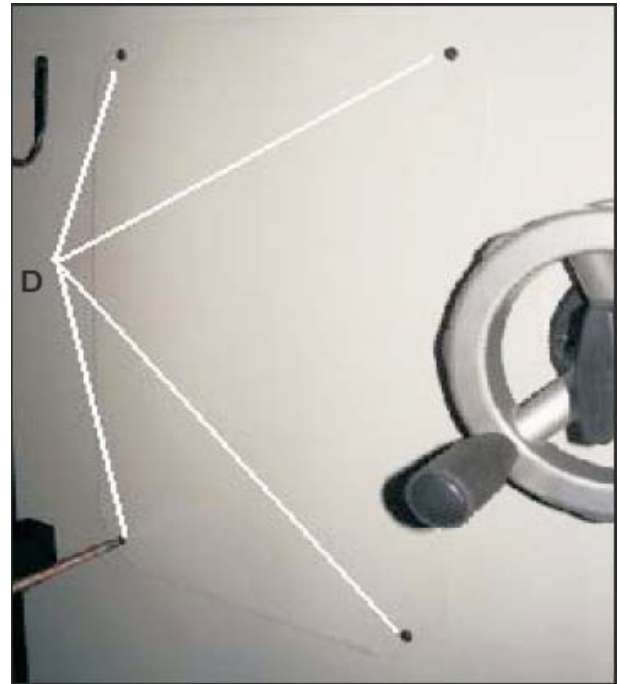
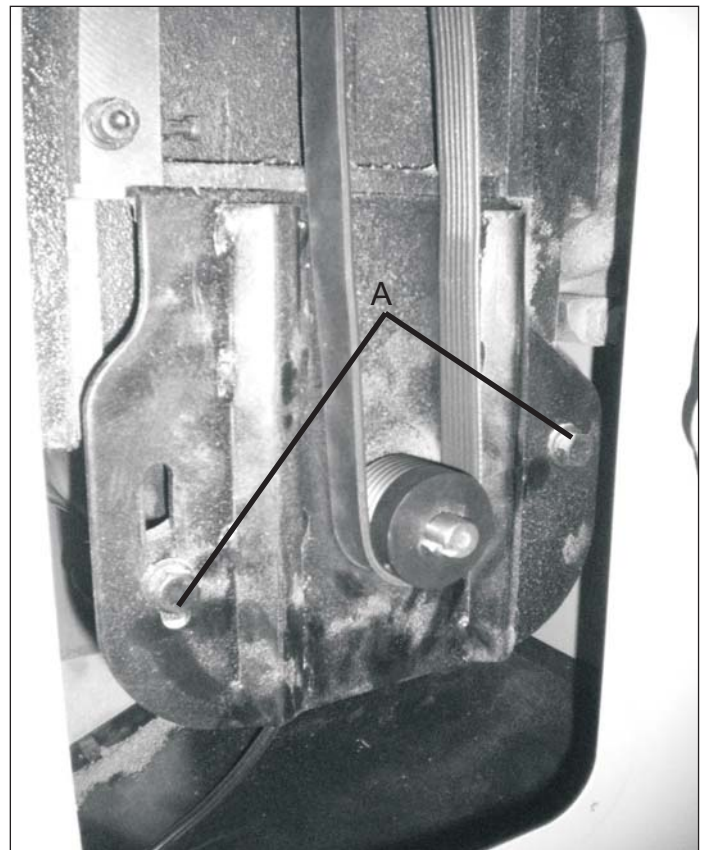

Fig. 6



GRANITE EXTENSION WING ASSEMBLY FOR 35971/35972

▲WARNING

MAKE CERTAIN THAT THE SAW IS DISCONNECTED FROM THE POWER SOURCE.

CAUTION: The granite extension wing is heavy; two people are required for assemble.

1. One person put left extension wing on the top of cabinet. Alignment pin into bottom of wing (A).
SEE FIG.9

Fig.9

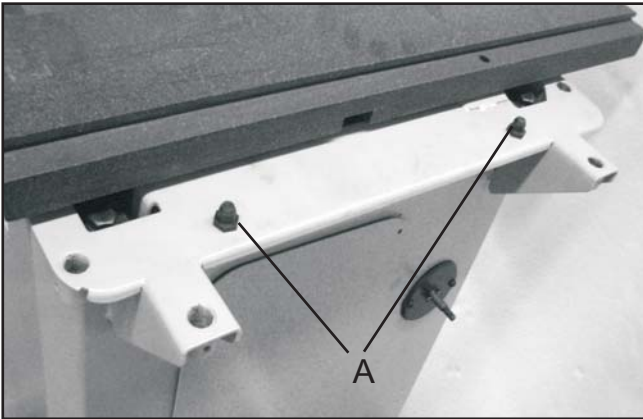

2. Another person locks 4 bolts (A) with flat and spring washer and from the bottom of cabinet and tighten it.
SEE FIG. 10

Fig.10

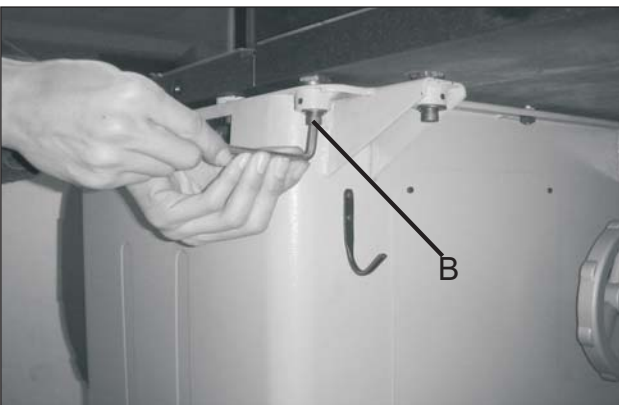

NOTE: Need not adjust the flatness for extension wings after assembling. Because we have done the pre-adjustment and pre-setting of the extension wings for the flatness in factory.

3. The user can fine tune the flatness for the extension Wings.

4. To loose 4 screws (B) by 6.0mm Allen Wrench;
5. To loose 4 setting screws (C) by 2.5mm Allen wrench.
SEE FIG.11

Fig.11



6. Using an open wrench (D) to adjust the 4 elevation screws (E) to raise or lower the extension wing to the table. **SEE FIG.12**

Fig.12

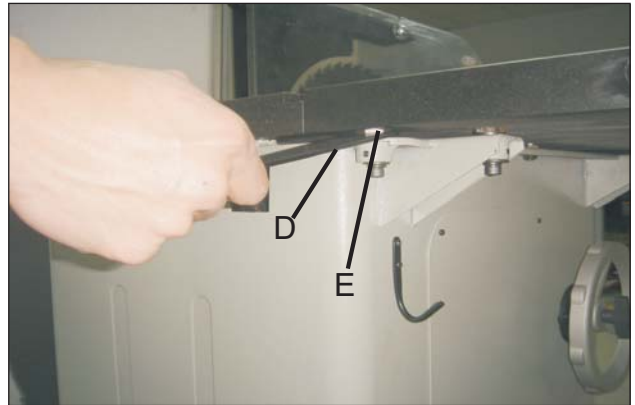

7. Use a straight edge across to the main table and extension wings, checking the flatness of both main and extension wings. **SEE FIG.13**

Fig.13

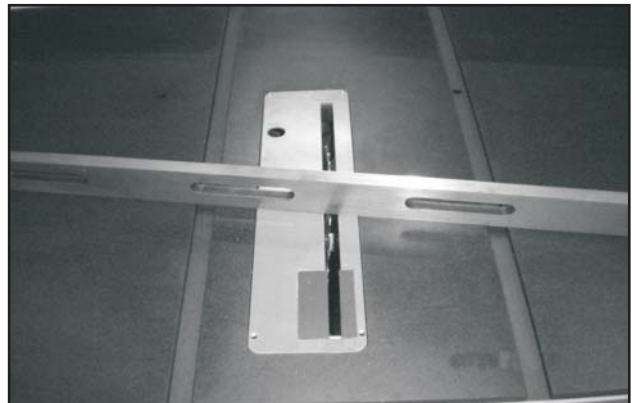

8. Make sure both wings are aligned, if not, refer to step (6) until completely adjusted.
9. Using a 6.0mm Allen wrench to secure 4 screws (B).

**The assembly method for 35963/35964
Extension wing is the same as 35971/35972**

RIVING KNIFE/SPLITTER COMPONENTS ASSEMBLY

⚠ WARNING

MAKE CERTAIN THAT THE SAW IS DISCONNECTED FROM THE POWER SOURCE.

Note: Remove the table insert (Table insert are gripped by four magnets on the table).

Fig.14

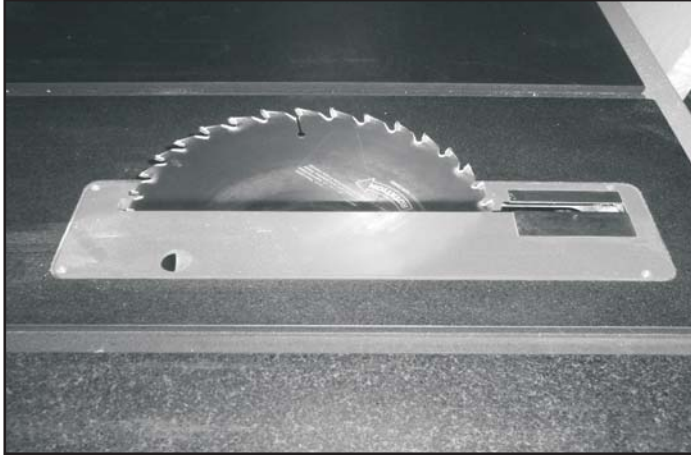

INSTALLING AND REMOVING THE RIVING KNIFE/SPLITTER

1. Loosen the knob (C), Line up the riving knife/splitter in the proper direction to the mounting bracket (B). **SEE FIG.15.**
2. Push the Riving Knife/splitter all the way down into the mounting bracket, make sure the location pin is properly locked in the hole of the Riving Knife/splitter. (The location hole is on the button side of the Riving Knife/splitter).
3. Tighten the fastening knob(C). **SEE FIG.16**

•Remove

1. Loosen the fasten knob (C).
2. Remove the Riving Knife/splitter out of mounting bracket.

NOTE: Make sure blade or arbor is at the highest position before adding or removing the riving Knife/splitter.

Fig.15

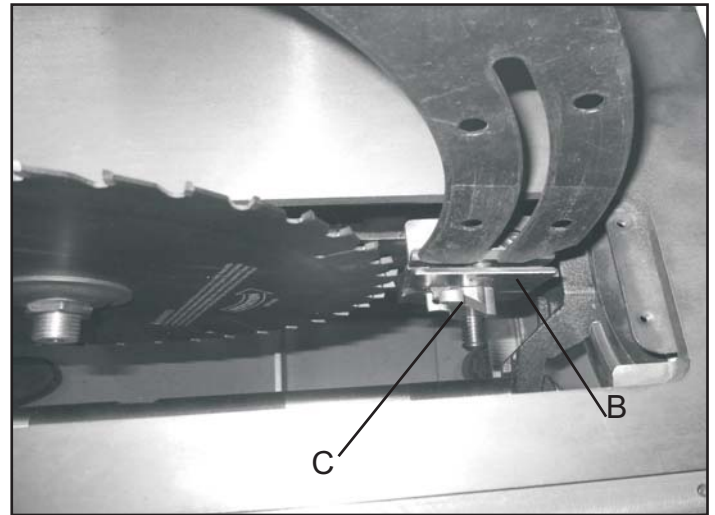
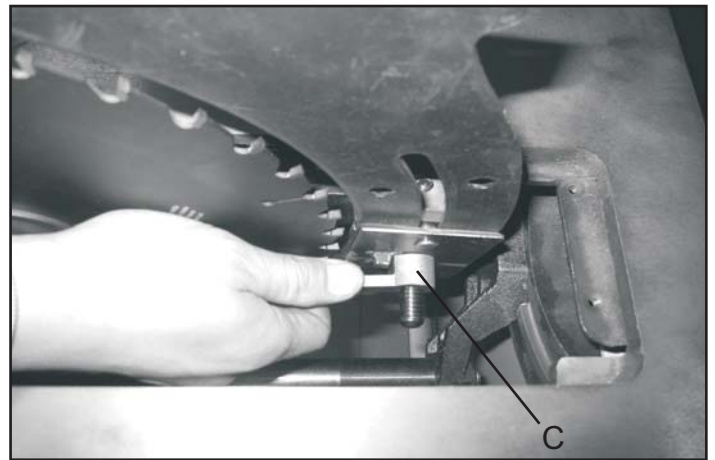

Fig.16



BLADE ASSEMBLY

⚠ WARNING

MAKE CERTAIN THAT THE SAW IS DISCONNECTED FROM THE POWER SOURCE.

Fig. 17

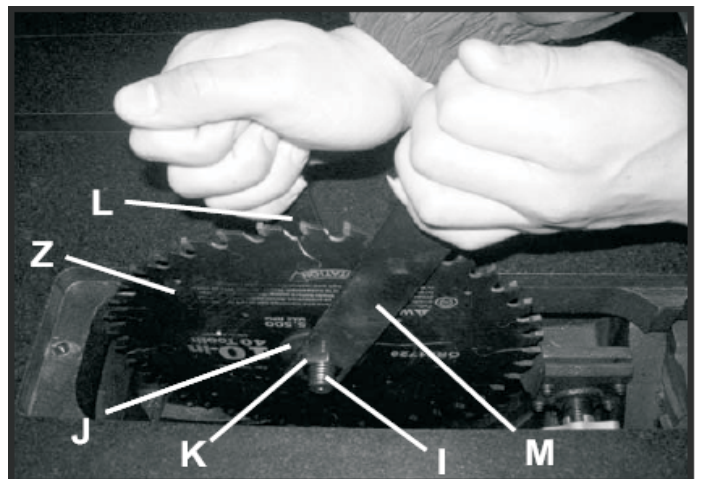

1. Remove the hex nut (K) and outer flange (J) from the blade arbor (I). Note: The arbor has a right hand thread; to loosen the hex nut turn it counterclockwise.
2. Place a 10" saw blade (Z) onto the blade arbor (I), make sure the teeth of the blade are pointing down in the front of the table saw. Place the outer flange (J) and hex nut (K) onto the blade arbor and snug hex nut by hand. Place the open-end blade wrench (L) on the flats of the inner blade flange (not shown) and the box-end blade wrench (M) onto the hex nut and securely tighten.
Note: The blade arbor has a right hand thread, to tighten the hex nut turn it clockwise. **SEE FIG.17**

Fig. 18

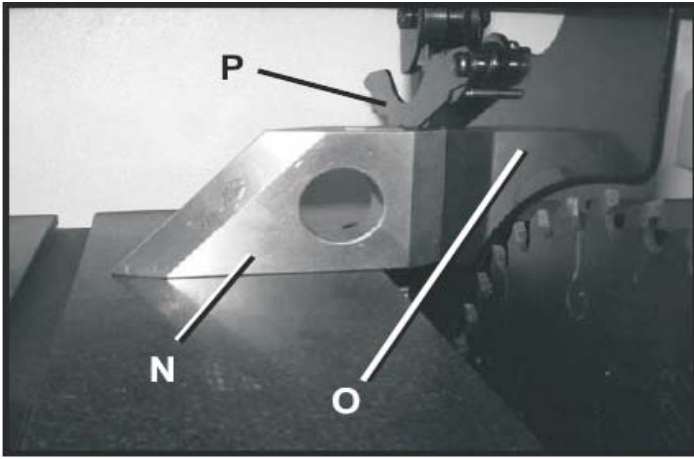

3. Place a square (N) onto the saw blade and against the splitter assembly (O). Make sure the splitter is square to table. **SEE FIG.18**
4. Lay a straight edge (R) against the left side of the saw blade (S) Align the splitter and make sure the splitter is aligned to the blade.
SEE FIG.19

Fig.19

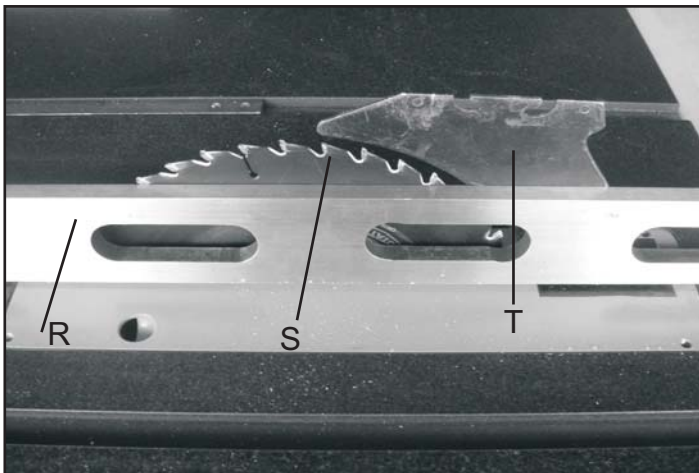

CONVERSION THE SPLITTER TO RIVING KNIFE

▲WARNING

MAKE CERTAIN THAT THE SAW IS DISCONNECTED FROM THE POWER SOURCE.

Note: Splitter can be used as riving knife.

1. Remove the guard assembly (C) and kick-back pawl assembly (D) by loosening knob (A) and (B). **SEE FIG.20**

Fig.20

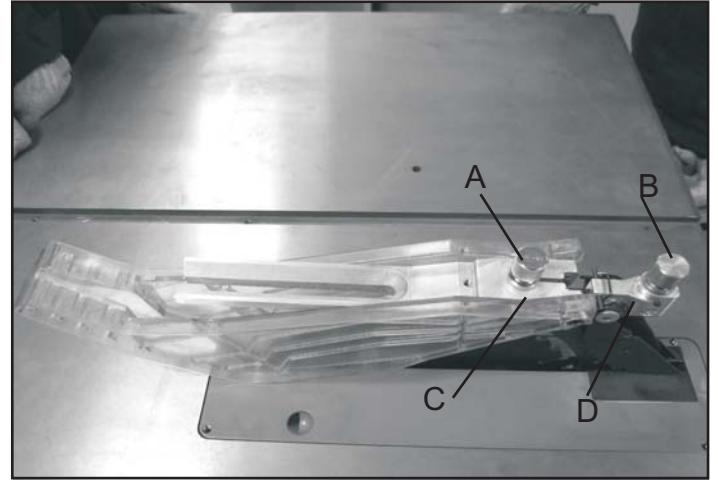

2. Remove the table insert, and make sure the location pin inside the bottom of the mounting bracket is properly insert into the location hole (E) of splitter.
SEE FIG.21

Fig.21

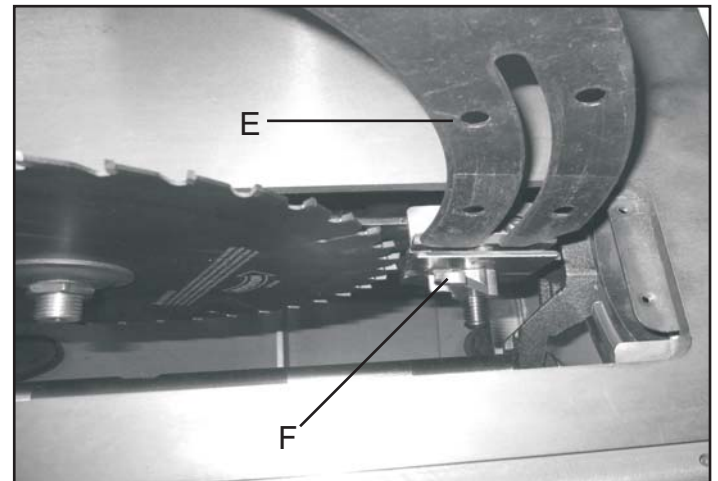

3. Tighten the Knob (F) and re-install the table insert.

CONNECTING SWITCH CORD TO MOTOR CORD

⚠ WARNING

MAKE CERTAIN THAT THE SAW IS DISCONNECTED FROM THE POWER SOURCE.

1. Place the switch cord (A) through hole (B) in front of Cabinet. **SEE FIG. 22**
2. Open motor cover, insert three prong switch cord (C) into three hole outlet (D) of the motor cord. **SEE FIG,23**

Fig.22

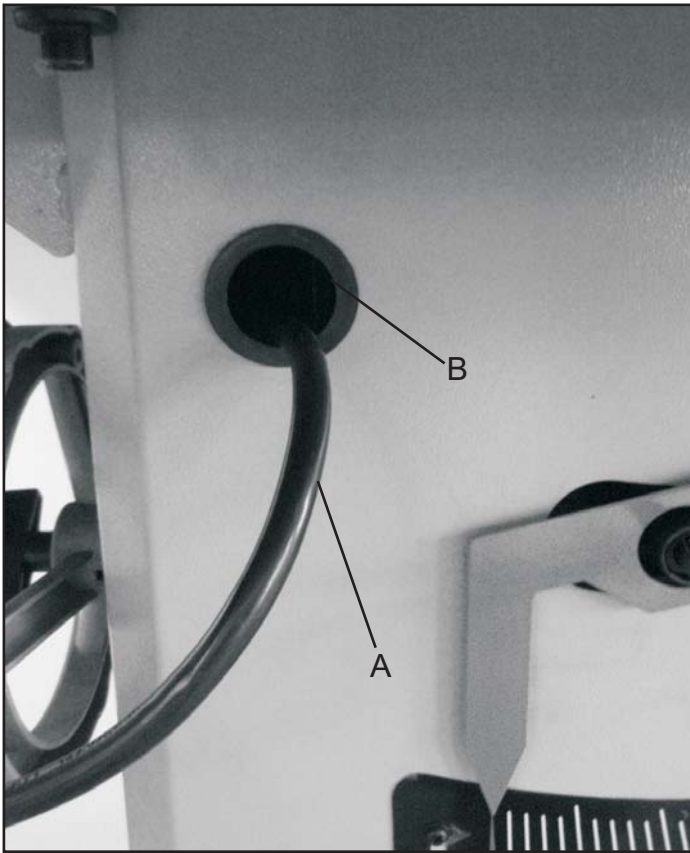

3. Pull slack in switch cord into the cabinet.
Make sure that the power cord inside of the cabinet is properly routed and clear of the saw blade and any pinch points for all blade height and blade angle Settings

Fig.23

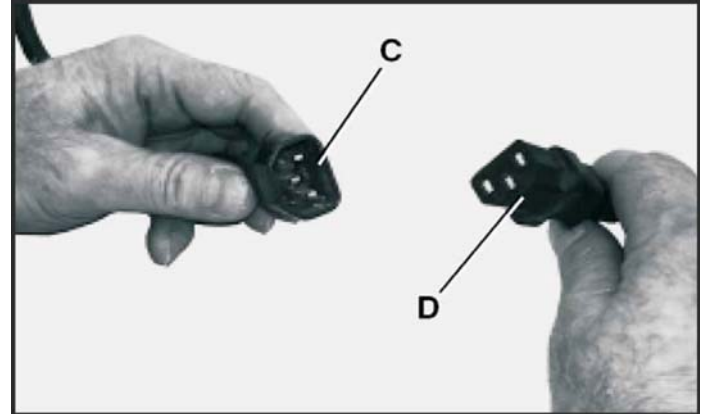

MOUNTING RAILS, FENCE, POWER SWITCH AND TABLE BOARD

The rail, fence assembly, power switch, and table board can now be mounted to the saw. See Owner's Manual for Fence Assembly Instructions which will address the mounting of these parts.

ADJUSTMENTS

RAISING AND LOWERING THE BLADE

Fig. 24

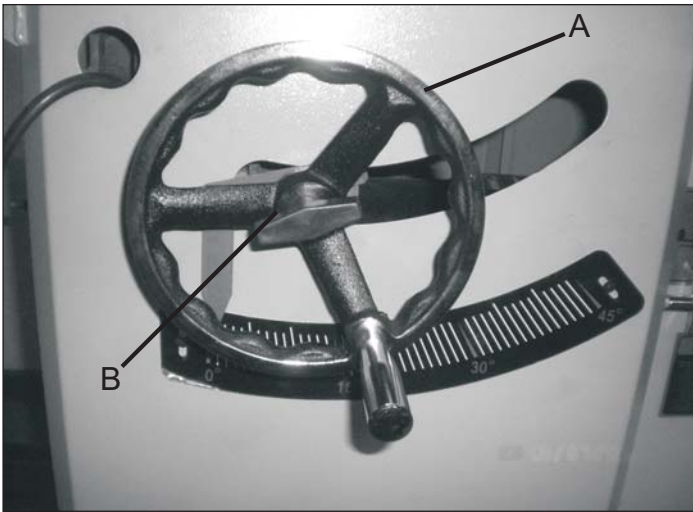

The blade height adjustment handwheel and handwheel lock knob are located on the front of the cabinet above the blade bevel scale. To raise the saw blade, loosen the handwheel lock knob (A) (counterclockwise) and turn the handwheel (B) clockwise. When the saw blade is at its desired height, tighten the handwheel lock knob (clockwise) until it is securely tightened. **SEE FIG 24**

To lower the saw blade, loosen the handwheel lock knob (counterclockwise) and turn the handwheel counterclockwise. When the saw blade is at its desired height, tighten the handwheel lock knob (clockwise) until it is securely tightened.

TILTING THE BLADE

The blade bevel handwheel and handwheel lock knob are located on the left side of the cabinet. To increase the saw blade bevel, loosen the handwheel lock knob (counterclockwise) and turn the hand wheel clockwise. When the saw blade is at its desired degree, tighten the handwheel lock knob (clockwise) until it is securely tightened.

To return the saw blade bevel to zero degrees, loosen the handwheel lock knob (counterclockwise) and turn the handwheel counterclockwise. When the saw blade is back to zero degrees it will come into contact with the adjustable positive stop which will cause the blade to stop. Tighten the handwheel lock knob (clockwise) until it is securely tightened.

To tilt the blade bevel to 45-degrees, loosen the hand-wheel lock knob (counterclockwise) and turn the hand-wheel clockwise. When the saw blade is at 45-degrees it will come into contact with the adjustable positive stop which will cause the blade to stop. Tighten the hand-wheel lock knob (clockwise) until it is securely tightened.

ADJUSTING BLADE BEVEL POSITIVE STOPS

Fig. 25

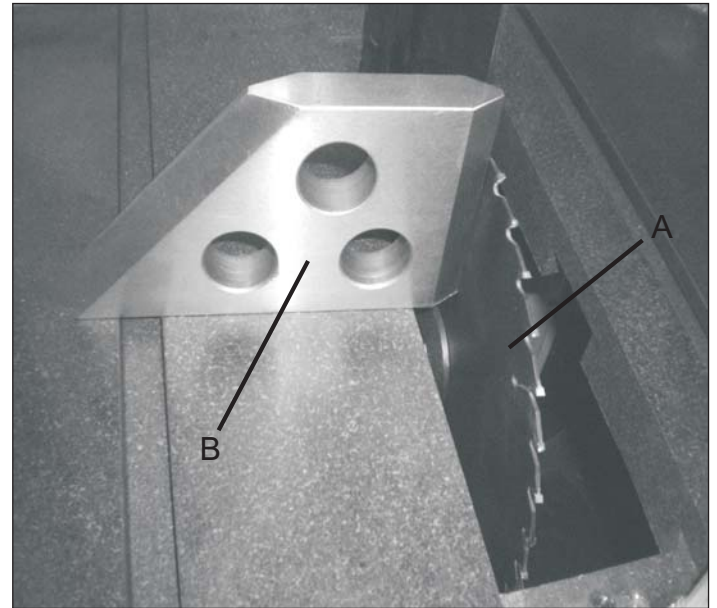

1. To adjust blade to a 90-degree blade bevel positive stop, raise the saw blade (A) to its highest position. **SEE FIG 25**
2. Using a combination square (B) check that the blade is 90 degrees to the saw table (zero degrees on bevel scale).
3. If the blade will not tilt to 90 degrees, turn (counterclockwise) the set screw in the left miter slot of the saw table until the blade can be positioned to 90 degrees.
4. Once the blade has been tilted to 90 degrees (confirm this using your square), tighten the bevel handwheel lock knob, located on the side of the cabinet. This will keep the blade from tilting further.
5. Turn the set screw (clockwise) until it comes in contact with the positive stop.
6. Loosen the bevel handwheel lock knob located on the side of the cabinet, and rotate bevel handwheel until the blade is at 45 degrees to the saw table.
7. If the blade will not tilt to 45 degrees, turn (counterclockwise) the set screw located just to the right of the right miter slot, until the blade can be positioned to 45 Degrees.

Fig. 26

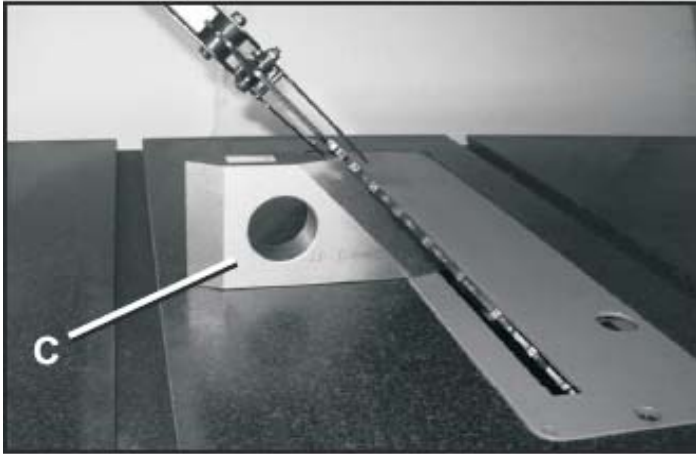

8. Using a combination square (C), make sure that the blade is at 45 degrees. **SEE FIG 26**
9. With the blade at 45 degrees, tighten the bevel handwheel lock knob to keep the blade from further tilting.
10. Turn the set screw clockwise until it comes in contact with the positive stop.

CHECKING BLADE ALIGNMENT

Blade heel is the misalignment of the blade to the miter slots. This means that the blade is not parallel to the miter slots. The blade is set parallel at the factory and should not need any adjustments. You can check this by using a dial indicator (not included) or a combination square (not included). It is recommended to check the alignment before initial operation as follows:

▲WARNING

MAKE CERTAIN THAT THE SAW IS DISCONNECTED FROM THE POWER SOURCE.

Fig. 27

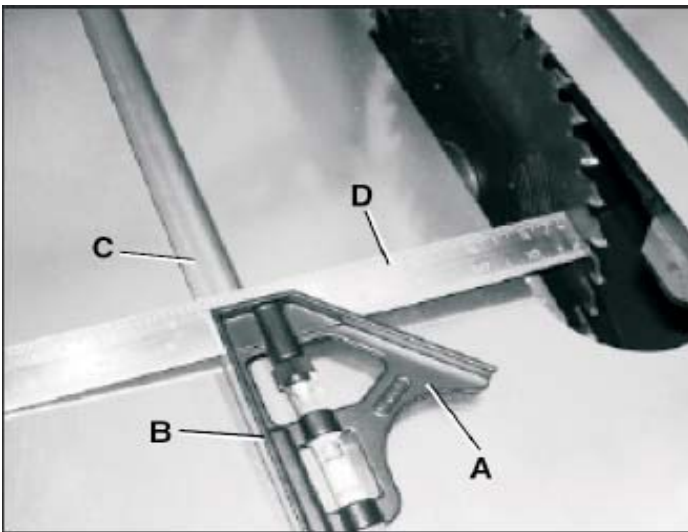

1. Raise the saw blade to its highest point.
2. Place a combination square (A) on the saw table with one edge (B) of the square against the left miter slot (C). **SEE FIG 27.**
3. Adjust the square so the rule (D) just touches the saw blade. Make sure the rule is not touching any of the carbide tips of the saw blade.
4. Lock the rule in this position.

Fig. 28



6. Rotate the saw blade back so that you take the measurement from the same spot on the saw blade.

SEE FIG 28

7. Take a reading at the rear of the blade (E) with the combination square. If there is a difference of more than .01 in between the rule and the blade, then an adjustment will have to be made.

ADJUSTING BLADE ALIGNMENT

NOTICE: Blade alignment is factory set and should not need adjustment. All saw blades have some runout. Therefore, readjusting the blade alignment should only be attempted if it becomes necessary (see "CHECKING BLADE ALIGNMENT")

▲WARNING

MAKE CERTAIN THAT THE SAW IS DISCONNECTED FROM THE POWER SOURCE.

1. To align the blade parallel to the miter slot, first loosen two hex soc head screws (A) under the front side of the table saw. This is the same side as the raise/lower handwheel (B). **SEE FIG. 29**

Fig.29

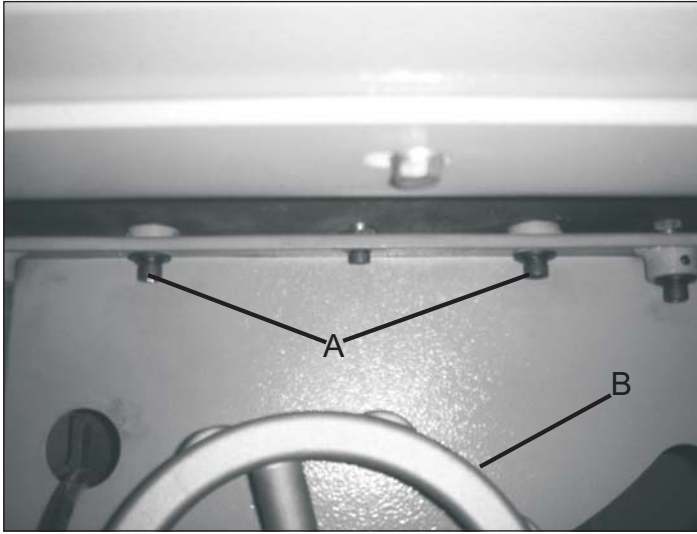

2. Remove the End cap on the rear side of the table saw, Loosen two hex soc head screws (C). **SEE FIG.30**

Fig.30

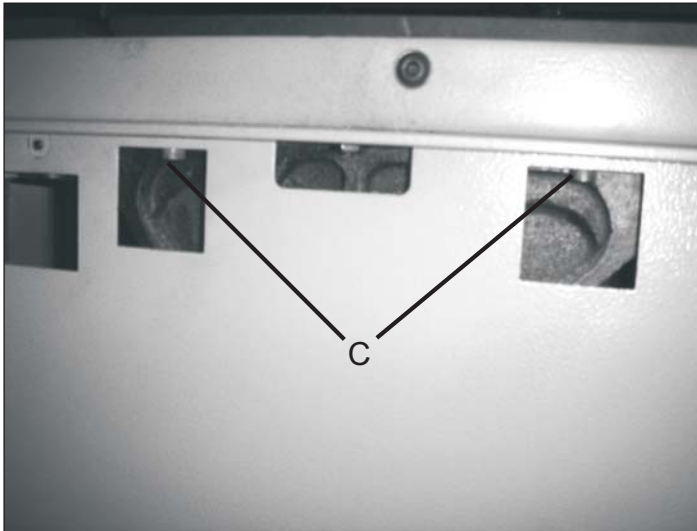

3. The saw table is now loose and can be repositioned until the blade is parallel to the miter slot. Repeat steps in **"CHECKING BLADE ALIGNMENT."**
4. When blade is parallel to miter slot, tighten all four hex soc head screws.
5. Recheck blade alignment.
6. Tilt the blade to 45 degrees, and rotate the saw blade by hand. Make sure the blade does not contact the table insert.

BEVEL ARROW ADJUSTMENT

1. Make certain that the blade is at 90-degrees to the Table surface with a combination square.

Fig. 31

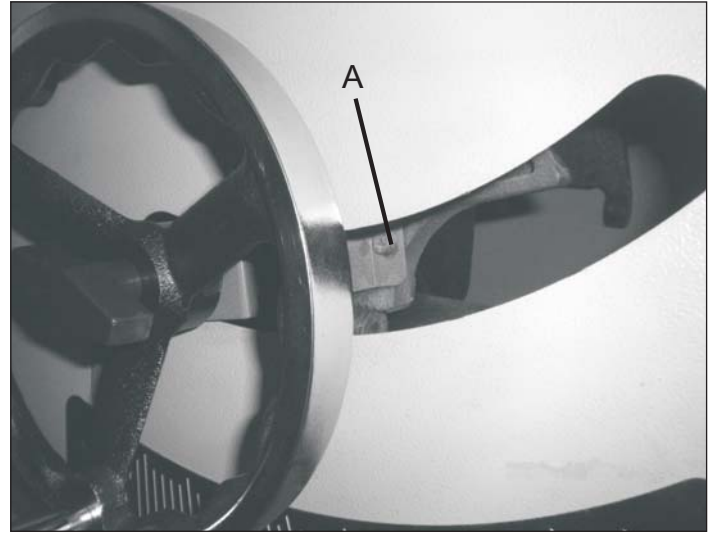

2. Check that the bevel arrow is pointing to the zero degree mark on the bevel scale located on the front of the cabinet. **SEE FIG 31.**
3. To adjust arrow, loosen the Philips head screw (A), and reposition the bevel arrow and tighten screw.

TABLE INSERT ADJUSTMENT

▲WARNING

MAKE CERTAIN THAT THE SAW IS DISCONNECTED FROM THE POWER SOURCE.

Fig. 32

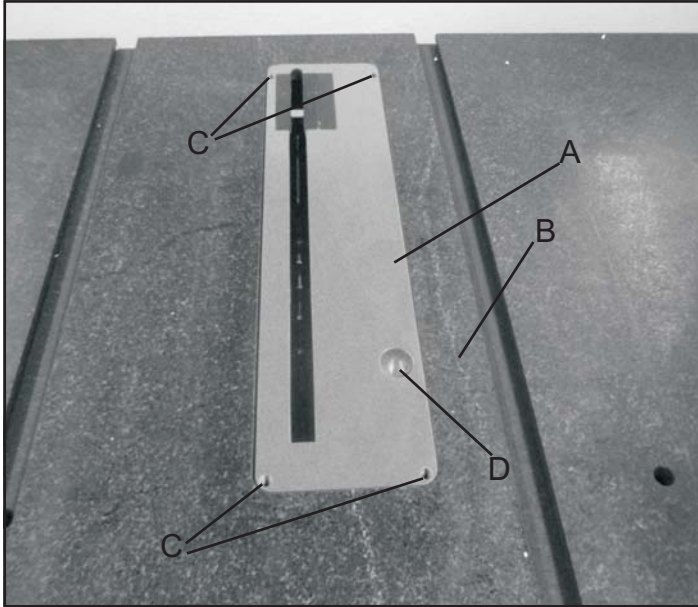

1. The table insert (A) must always be level with the saw table (B).
2. Place a straight edge across the front and rear of the table insert. Check that the insert is perfectly level with the saw table.
3. To level the table insert, turn the one or more adjusting set screws (C) as needed and recheck.
5. The table insert is equipped with a finger hole (D) for easy removal. **SEE FIG. 32**

MITER GAUGE ADJUSTMENT

▲WARNING

MAKE CERTAIN THAT THE SAW IS DISCONNECTED FROM THE POWER SOURCE.

Fig. 33

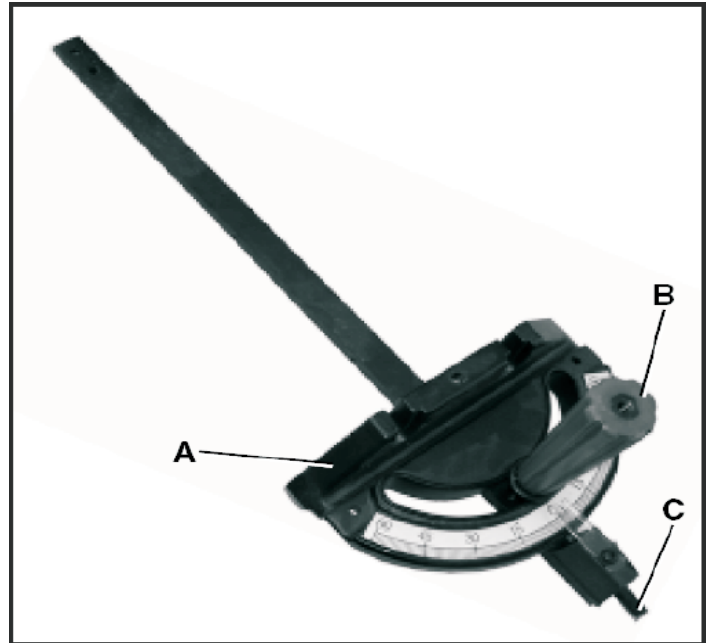

1. The miter gauge has adjustable positive stops at 0-degree and 45-degrees or it can be manually set at any angle between 60-degrees.
2. To rotate miter gauge body (A), loosen knob (B) and pull out plunger (C) and rotate miter gauge body to desired angle and tighten knob. **SEE FIG 33**
3. To rotate to the next positive stop, pull plunger (C) out, rotate miter gauge body then push plunger back in and continue rotating miter gauge body until it stops Against next positive stop.

ADJUSTING POSITIVE STOPS

Fig. 34

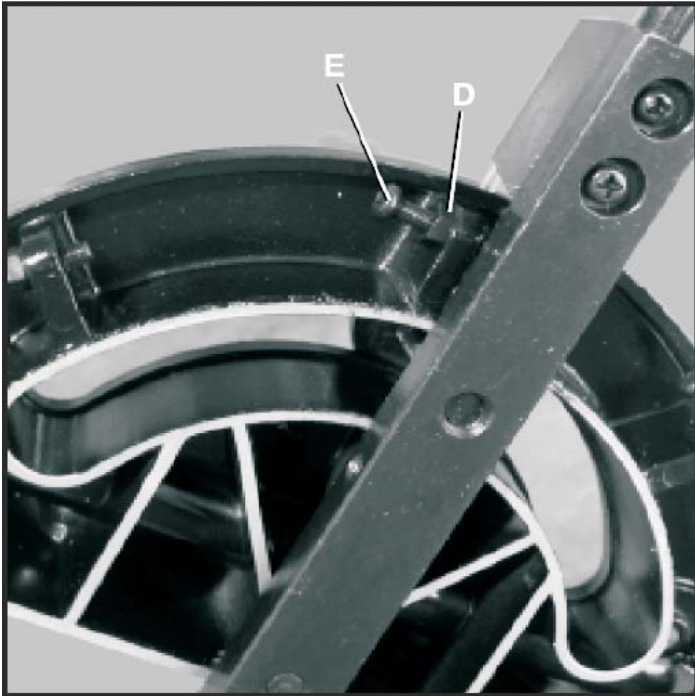

1. To adjust 0-degree positive stops, loosen knob (B), pull out on plunger (C) and turn miter gauge over.
2. Loosen the lock nut (D) 3 or 4 turns. **SEE FIG 34.**
3. Place a square against the guide bar and front of the miter gauge body. Square the miter gauge body to the guide bar and tighten knob.
4. Push in plunger and make adjustments to stop screw (E) so that it touches the plunger and tighten lock nut.
5. Recheck the positive stop angle to the saw blade. insert the guide bar into the miter slot and slide the miter gauge up to the saw blade.
6. To check, place a square against the saw blade and miter gauge body. If any more adjustments are needed repeat steps above.
7. To set both 45-degree positive stops, repeat steps 1 Thru 6 above at the 45-degree settings.

Arbor gib assembly adjustment

A dovetail gib is provided on the arbor height assembly to insure a good sliding fit between the arbor assembly and the trunnion bracket when raising and lowering the blade. This gib has been adjusted at the factory and should not need any further adjustment. If adjustment is necessary, perform the following steps.

1. First remove the access panel on the left side of the saw cabinet. **SEE FIG.35**

Fig.35

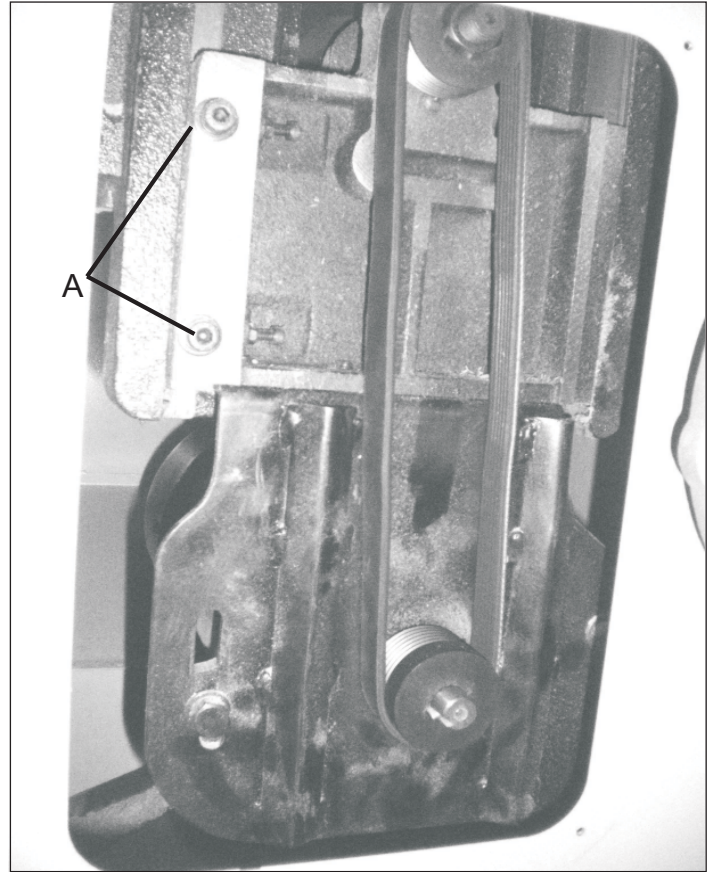

2. While holding the 8mm hex head bolt(A) with a wrench, loosen the hex nut only slightly (less than 1/8" of a turn). **SEE FIG.35**

Fig.36



3. Tighten the 5mm hex head bolts (B) slightly. Correct adjustment is when a good snug sliding fit is obtained without any side play or movement between the mating dovetail surfaces. The adjustment should not be too tight that it restricts the sliding movement when the blade is raised and lowered or too loose that it affects accuracy. **SEE FIG.36**
4. Once proper fit is achieved, retighten the (2)8mm hex Head bolts(A) and M5 hex nut against the casting.

OPERATIONS

⚠ CAUTION

A separate electrical circuit should be used for your table saw. The circuit should not be less than #14 AWG wire and should be protected with a 15-amp time lag fuse.

Have a qualified electrician repair or replace damaged or worn cord immediately.

Before connecting the motor to the power line, make certain the switch is in the "OFF" position and be sure that the electric current is of the same rating as the motor nameplate. All line connections should make good contact.

Running on low voltage or long, under rated extension Cords will damage the motor.

⚠ WARNING

DO NOT expose the table saw to rain or operate the in damp locations.

MAKE SURE all parts have been assembled correctly and are in working order.

KEEP table surface clear of tools and debris before starting table saw.

STARTING AND STOPPING THE SAW

Fig .37

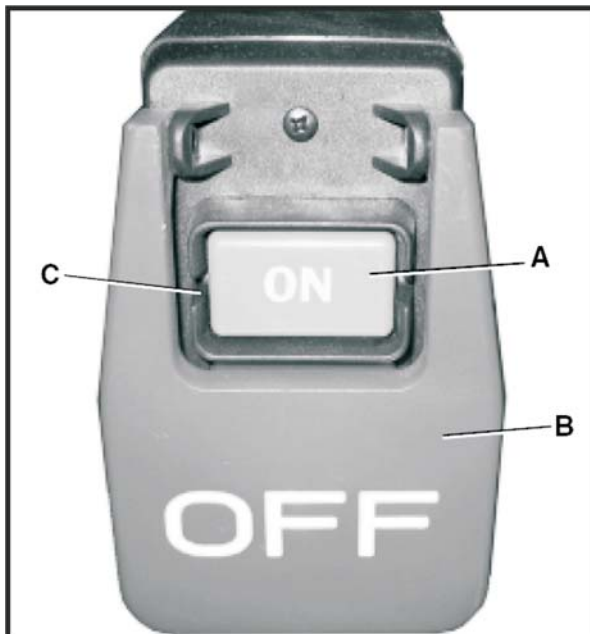

1. The ON/OFF switch is located under the front rail on the table saw.
2. To turn the table saw on, press the green ON button (A) in one half inch. **Note:** There is a safety feature on the switch to insure that the switch must be completely pressed before the saw will start. **SEE FIG.37**

3. To turn the table saw off, press the large red "OFF" paddle (B) or lift the paddle and press directly on the Red " OFF" button.
4. When the table saw is not in use, the "ON" button (B) should be locked so that it cannot be started.
5. Using a padlock (not provided) , it is possible to lock the switch to prevent unauthorized use. Lift the red "OFF" paddle and place a padlock through the holes (C) in the side of the "ON" button and then lock the padlock. Make sure keys have been removed from padlock and placed where no children can get them. **SEE FIG.37**

⚠ WARNING

MAKE CERTAIN THAT THE SAW IS DISCONNECTED FROM THE POWER SOURCE.

⚠ WARNING

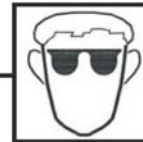

ALWAYS wear eye protection. Any machine can throw debris into the eyes during operations, which could cause severe and permanent eye damage. Everyday eyeglasses are **NOT** safety glasses. **ALWAYS** wear Safety Goggles (that comply with ANSI standard Z87.1) when operating power tools.

⚠ WARNING



ALWAYS wear a NIOSH/OSHA approved dust mask to prevent inhaling dangerous dust or airborne particles.

THERMAL-OVERLOAD PROTECTION

⚠ WARNING

- Turn the power switch "OFF" and unplug the power cord from its power source prior to doing or performing any maintenance.
 - Make certain that the "OFF" button has been depressed before pushing the thermal-overload reset button.
- The motor supplied with your table saw has a (resettable) thermal-overload relay located on the side of the switch. If the motor shuts off during an operation (cutting a workpiece too fast or using a dull blade, using the saw beyond its capacity, or low voltage) press the "OFF" button and let the motor cool three to five minutes.

Push the reset thermal-overload button on the side of the ON/OFF switch assembly. Make certain that the saw blade and work are has been cleared of debris before restarting saw. The motor can now be turned on again.

▲WARNING

MAKE CERTAIN THAT THE SAW IS DISCONNECTED FROM THE POWER SOURCE.

▲WARNING



ALWAYS wear eye protection. Any machine can throw debris into the eyes during operations, which could cause severe and permanent eye damage. Everyday eyeglasses are **NOT** safety glasses. **ALWAYS** wear Safety Goggles (that comply with ANSI standard Z87.1) when operating power tools.

▲WARNING



ALWAYS wear a NIOSH/OSHA approved dust mask to prevent inhaling dangerous dust or airborne particles.

▲WARNING

The following section was designed to give instructions on the basic operations of this table saw. However, it is in no way comprehensive of every table saw application. It is strongly recommended that you read books, trade magazines, or get formal training to maximize the potential of your table saw and to minimize the risks.

▲WARNING

MAKE CERTAIN THAT THE SAW IS DISCONNECTED FROM THE POWER SOURCE.

PRE-RUN CHECK

Before you begin to use your Table Saw, you should give it a thorough inspection, making sure you ask yourself the following questions:

1. Is the blade mounted correctly?
2. Is the saw stable?
3. Is it wired properly?
4. Is the electrical system properly configured?
5. Have you checked your workpiece for obvious Defects?

6. Is the guard assembly installed and functional?
7. Have you checked the saw blade clearance when it is adjusted to varying angles and depths?
8. Have you read all the warnings and directions regarding the operation of this machine?

TEST RUN

1. Face the table saw and stand to the left of the blade path.
2. With one finger on the ON button and one finger on the OFF button, turn the saw on. Be ready to turn the saw off in case of a mishap.
3. Watch and listen to the saw. Note whether there are any unusual sounds or excessive vibrations.
4. If anything appears abnormal, immediately turn off the saw, unplug it, and fix the problems. If a problem exists that is beyond the scope of this manual, contact your dealer.
5. If the saw is operating properly, turn it off and prepare to make a cut according to the instructions outlined in this section.

BLADE SELECTION

Choosing the correct blade for the job is essential for the safe and efficient use of your table saw. Ignoring this important step could result in damage to the saw and serious injury to the operator. Below are the most common saw blades and their uses.

1. **Rip Blade:** Used for cutting with the grain. Typically, 10 rip blades have between 18-40 teeth and large gullets to allow for large chip removal. **SEE FIG 38.**

Fig.38

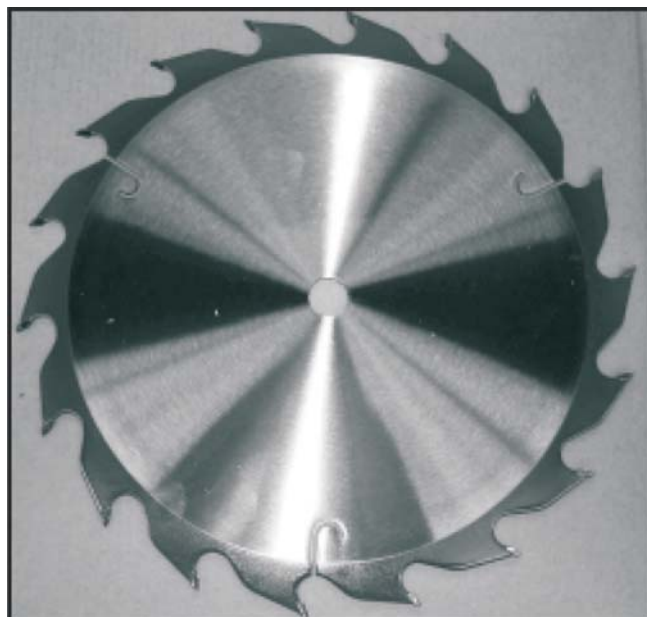

2. **Cross-cut Blade:** Used for cutting across the grain. 10 cross-cut blades have between 60-80 teeth and a shallow gullet. **SEE FIG 39.**

Fig.39

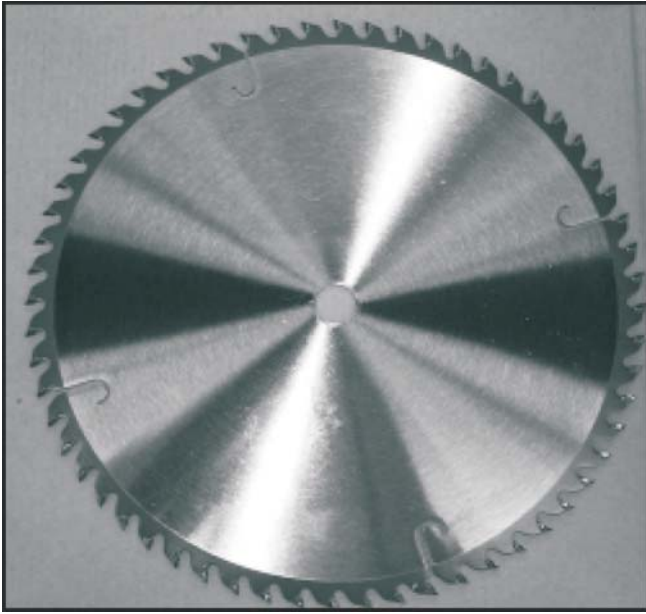

3. Used for cutting with and across the grain. A compromise between a rip blade and a cross-cut blade, a 10 combination blade will typically have between 40-50 teeth. **SEE FIG.40**

Fig.40

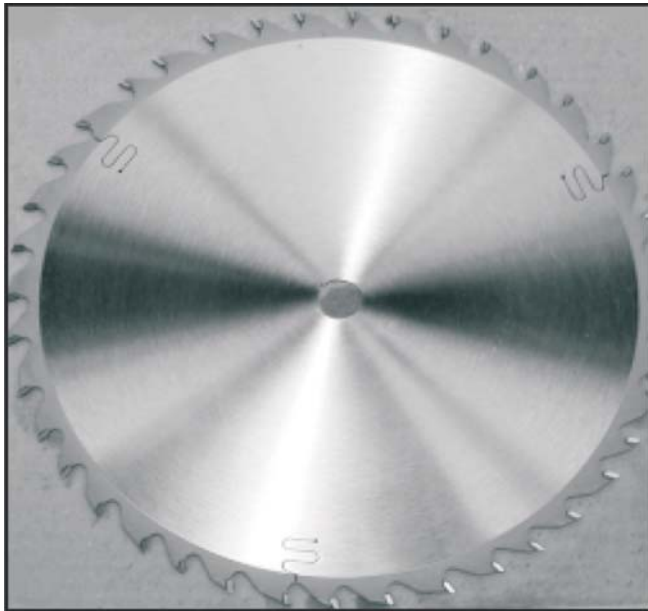

4. **Thin-kerf blade:** Most types of saw blades are available in a thin-kerf style. Designed primarily to minimize stock waste, thin-kerf blades are used in conjunction with a blade stabilizer to reduce blade wobble. **Note:** Many blade guards/splitters are thicker than many thin-kerf blades. Make sure that the stock will pass by the guard/splitter before beginning a cut.

5. **Dado Blade:** There are two types of dado blades: stack and wobble. Stack dados involve more setup time, but they provide a superior finish cut when compared to a wobble dado. Dado blades require 13/16" max use of accessory dado table insert.

This section on blade selection is by no means comprehensive. Always follow the saw blade manufacturer recommendations to assure safe and efficient operation

CROSSCUTTING

Crosscutting means cutting across the grain of the wood. In wood products without grain (i.e. MDF, particleboard), crosscutting simply means cutting across the width of the stock.

Crosscuts are made with the miter gauge. There are two miter gauge slots in the table top. Use the one that works best for the piece being crosscut. **To make a crosscut using the miter gauge:**

1. Inspect the board for soundness. You do not necessarily need a square edge to crosscut with accuracy.
2. Inspect the miter gauge. Is it properly set and tight?
3. Move the rip fence completely out of the way.
4. Turn on the saw and allow it to come to full speed.
5. Hold the workpiece firmly against the face of the miter gauge and ease it into the blade and through the workpiece. **SEE FIG.41**

Fig.41

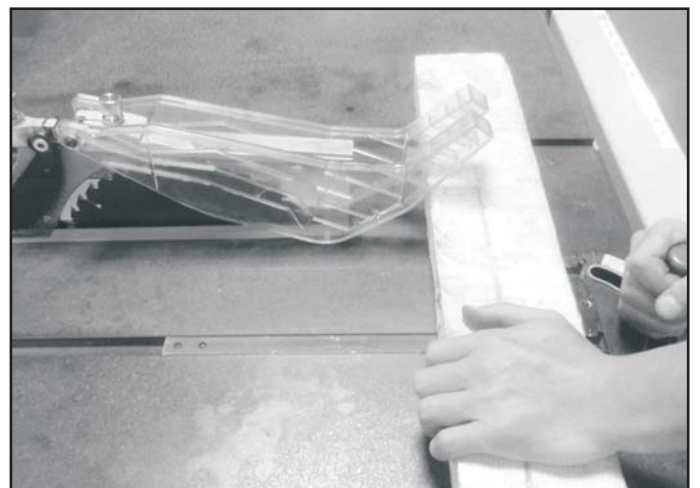

6. Turn off the saw and allow the blade to come to a full

RIPPING

Ripping means to cut with the grain of the wood. In other materials such as MDF or plywood, ripping simply means to cut lengthwise. **To rip a board:**

1. Inspect the board for soundness. You will need a straight edge to rip with accuracy. Your workpiece may need to be jointed flat before attempting to cut on the table saw.

⚠ WARNING

Never attempt to rip a board that does not have one perfectly straight edge and one flat side on it. Always run the straight edge of the board against the rip fence. Failure to do this could result in kickback and serious personal injury.

2. Set the rip fence to the desired distance from the blade. **IF YOU ARE MAKING NARROW CUTS, USE A PUSH-STICK.** Serious injury can occur if you put your hands close to the blade. A push-stick pattern has been included at the end of this manual. Use it to hold the workpiece against the table and fence and push the workpiece fully past the blade. When a small width is to be ripped and a push-stick cannot be safely put between the blade and rip fence, rip a larger piece to obtain the desired piece.

3. Turn on the saw and allow it to reach full speed. Place the straight edge of the board against the rip fence and the flat side on table top. Feed the work-piece slowly and evenly into the blade. When ripping, always stand off to the side of the workpiece and push it through, making sure to keep your fingers out of line with the blade. **SEE FIG.42**

Fig.42



Do not stand directly behind the workpiece when ripping. **SEE FIG.43**

Fig.43



⚠ WARNING

Stand out of the line of potential kickback. Hold the workpiece firmly against the fence and table. Do not allow your fingers to get close to the blade! Do not reach over the blade to off-load the workpiece.

DADO OPERATIONS

In addition to its ability to rip and crosscut lumber, the table saw is also an invaluable tool for creating a variety of dados. These non-through cuts can be created with specially-designed stacking or wobbling dado blades.

⚠ WARNING

Never allow hands or arms to be above or behind the saw blade. Should kickback occur, the hands and arms can be pulled into the saw blade. Serious injury will result.

⚠ WARNING

Never perform a through cut operation with a dado blade. A dado blade is designed to make non-through cuts only. Failure to follow these directions could result in serious injury.

⚠️ WARNING

Dado operations present very real hazards requiring proper procedures to avoid serious injury. The chance of kickback is always greater when dado blades are used so extra precautions must be used. Any movement of the stock away from the fence can cause kickback. Be certain that stock is flat and straight. Failure to follow these warnings could result in serious personal injury.

⚠️ WARNING

Always use push sticks, feather boards, push paddles and other safety accessories whenever possible to increase safety and control

Proper dado operations will differ depending on the blade system you choose. Consult the instructions included with your dado blades for directions regarding attachment and adjustment.

⚠️ WARNING

MAKE CERTAIN THAT THE SAW IS DISCONNECTED FROM THE POWER SOURCE.

1. Remove the table insert, splitter guard, and regular saw blade.
2. Attach and adjust the dado blade system as recommended in the dado blade's instructions.'
3. Install the dado table insert.(Not included)
4. Raise the blade system up to the desired depth of the dado. Make sure the dado blade will not cut through the workpiece.
5. Reconnect the saw to the power source.
6. If dadoing along the length of your workpiece, adjust the distance between the fence and the inside edge of the blade to suit your needs. When cutting across the wood grain, use the miter gauge as a guide while dadoing. **Remember:** Never use the fence as a stop in conjunction with your miter gauge.
7. Using a scrap piece as a test piece, switch on the saw and take a pass over the dado blade.
8. If the cut is satisfactory, repeat with your finish stock.
9. Avoid taking too deep a cut in a single pass. Make Incremental cuts to avoid kickback.

MAINTENANCE

BACKLASH ADJUSTMENTS FOR BLADE RAISING / LOWERING AND BLADE TILTING ASSEMBLIES

If any play is detected in the blade raising/lowering or blade tilting assemblies, the following adjustments should be made.

⚠️ WARNING

MAKE CERTAIN THAT THE SAW IS DISCONNECTED FROM THE POWER SOURCE.

NOTE: In the illustration below, the table saw has been turned upside down and the blade removed for clarity.

Fig.44

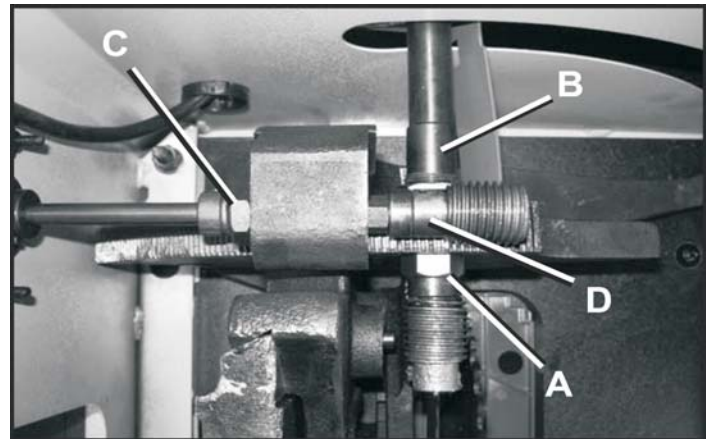

1. To adjust the blade raising/lowering assembly, loosen lock-nut (A) and turn the eccentric sleeve (B) until all play is removed in the assembly, then tighten locknut. **SEE FIG.44**
2. To adjust the blade tilting assembly, loosen lock-nut (C) and turn the eccentric (D) until all play is removed in the assembly, then tighten the lock-nut.

This table saw requires very little maintenance other than minor lubrication and cleaning. The following sections detail what will need to be done in order to assure continued operation of your saw.

LUBRICATION

The table saw has sealed lubricated bearings in the motor housing that do not require any additional lubrication from the operator.

Use a wire brush to clean off the worm gears and trunnions and apply a white lithium grease to keep them lubricated.

CLEANING

Keep the inside of the cabinet clear of saw dust and wood chips. With the table saw unplugged, vacuum out the inside of the cabinet or blow out the inside with an air hose. Be sure to use air pressure no higher than 50 P.S.I. as high pressure air may damage insulation.

▲ WARNING

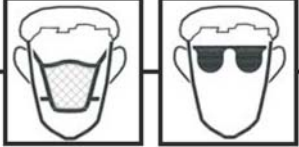

Be sure to wear protective eyewear and dust mask when cleaning out the cabinet of the saw.

TROUBLESHOOTING GUIDE

This section covers the most common processing problems encountered in sawing and what to do about them. Do not make any adjustments until the table saw is unplugged and moving parts have come to a complete stop.

PROBLEM	LIKELY CAUSE(S)	SOLUTION
Saw stops or will not start.	<ol style="list-style-type: none"> 1. Overload tripped. 2. Saw unplugged from wall or motor. 3. Fuse blown or circuit breaker tripped. 4. Cord damaged. 	<ol style="list-style-type: none"> 1. Allow motor to cool and reset by pushing reset switch. 2. Check all plug connections. 3. Replace fuse or reset circuit breaker. 4. Replace cord.
Does not make accurate 45° or 90° cuts.	<ol style="list-style-type: none"> 1. Stops not adjusted correctly. 2. Angle pointer not set accurately. 3. Miter gauge out of adjustment. 	<ol style="list-style-type: none"> 1. Check blade with square and adjust stops. 2. Check blade with square and adjust pointer. 3. Adjust miter gauge.
Material binds blade when ripping.	<ol style="list-style-type: none"> 1. Fence not aligned with blade. 2. Warped wood. 3. Excessive feed rate. 4. Splitter not aligned with blade. 	<ol style="list-style-type: none"> 1. Check and adjust fence. 2. Select another piece of wood. 3. Reduce feed rate. 4. Align splitter with blade.
Saw makes unsatisfactory cut.	<ol style="list-style-type: none"> 1. Dull blade. 2. Blade mounted backwards. 3. Gum or pitch on blade. 4. Incorrect blade for cut. 5. Gum or pitch on table. 	<ol style="list-style-type: none"> 1. Sharpen or replace blade. 2. Turn blade around. 3. Remove blade and clean. 4. Change blade to correct type. 5. Clean table.
Blade does not come up to speed.	<ol style="list-style-type: none"> 1. Extension cord too light or too long. 2. Low shop voltage. 3. Motor not wired for correct voltage. 	<ol style="list-style-type: none"> 1. Replace with adequate size cord. 2. Contact your local electric company. 3. Refer to motor junction box.
Saw vibrates excessively.	<ol style="list-style-type: none"> 1. Stand on uneven floor. 2. Damaged saw blade. 3. Bad poly V-belts. 4. Bent pulley. 5. Improper motor mounting. 6. Loose hardware. 7. Loose set screw in pulley. 	<ol style="list-style-type: none"> 1. Reposition on flat, level surface. 2. Replace saw blade. 3. Replace poly V-belts. 4. Replace pulley. 5. Check and adjust motor. 6. Tighten hardware. 7. Tighten set screw.
Rip fence binds on guide tube.	<ol style="list-style-type: none"> 1. Guide rails or extension wing not properly installed. 2. Guide of rip fence not adjusted properly. 	<ol style="list-style-type: none"> 1. Reassemble guide rails, refer to fence manual. 2. Adjust guides, refer to fence manual.
Material kicked back from blade.	<ol style="list-style-type: none"> 1. Rip fence out of alignment. 2. Splitter not aligned with blade. 3. Feeding stock without rip fence. 4. Splitter not in place. 5. Dull blade. 6. Letting go of material before it is past blade. 7. Anti-kickback fingers dull. 	<ol style="list-style-type: none"> 1. Align rip fence with miter slot. 2. Align splitter with blade. 3. Install and use rip fence. 4. Install and use splitter (with guard). 5. Replace blade. 6. Push material all the way past blade before releasing work. 7. Replace or sharpen anti-kickback fingers.
Blade does not raise or tilt freely.	<ol style="list-style-type: none"> 1. Sawdust and debris in raising and tilting 	<ol style="list-style-type: none"> 1. Clean and grease.

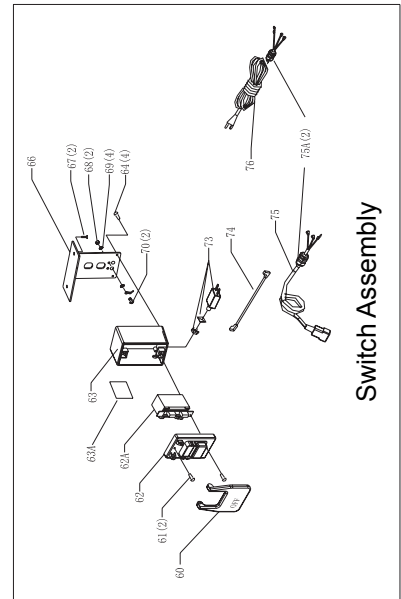
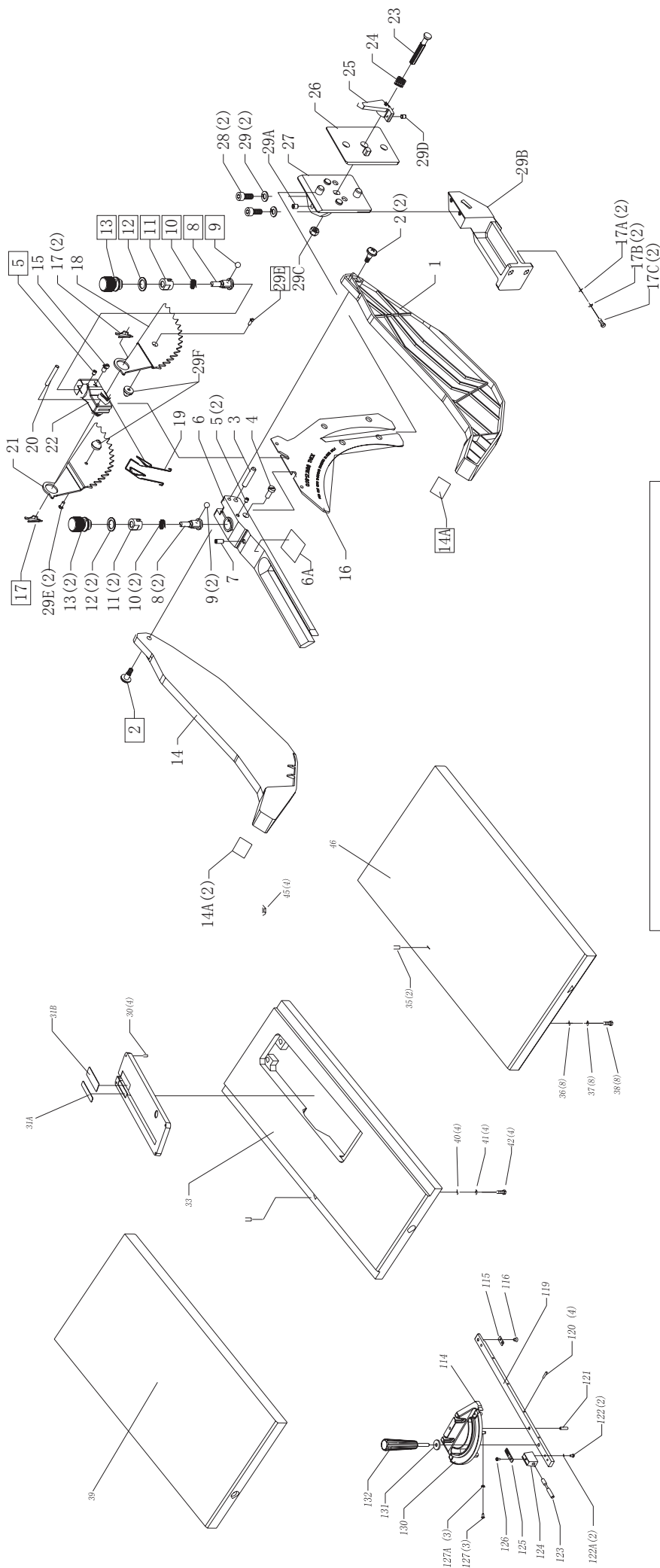

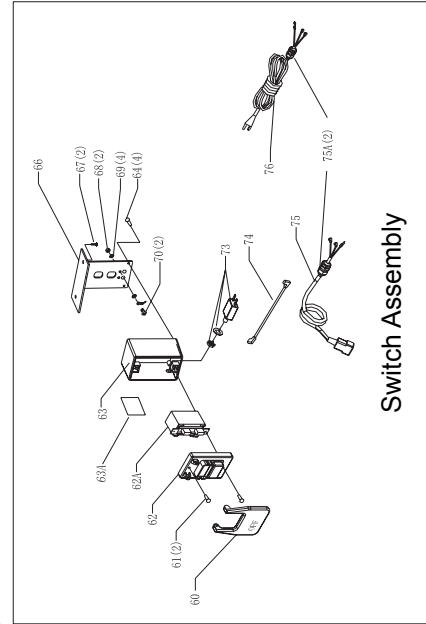
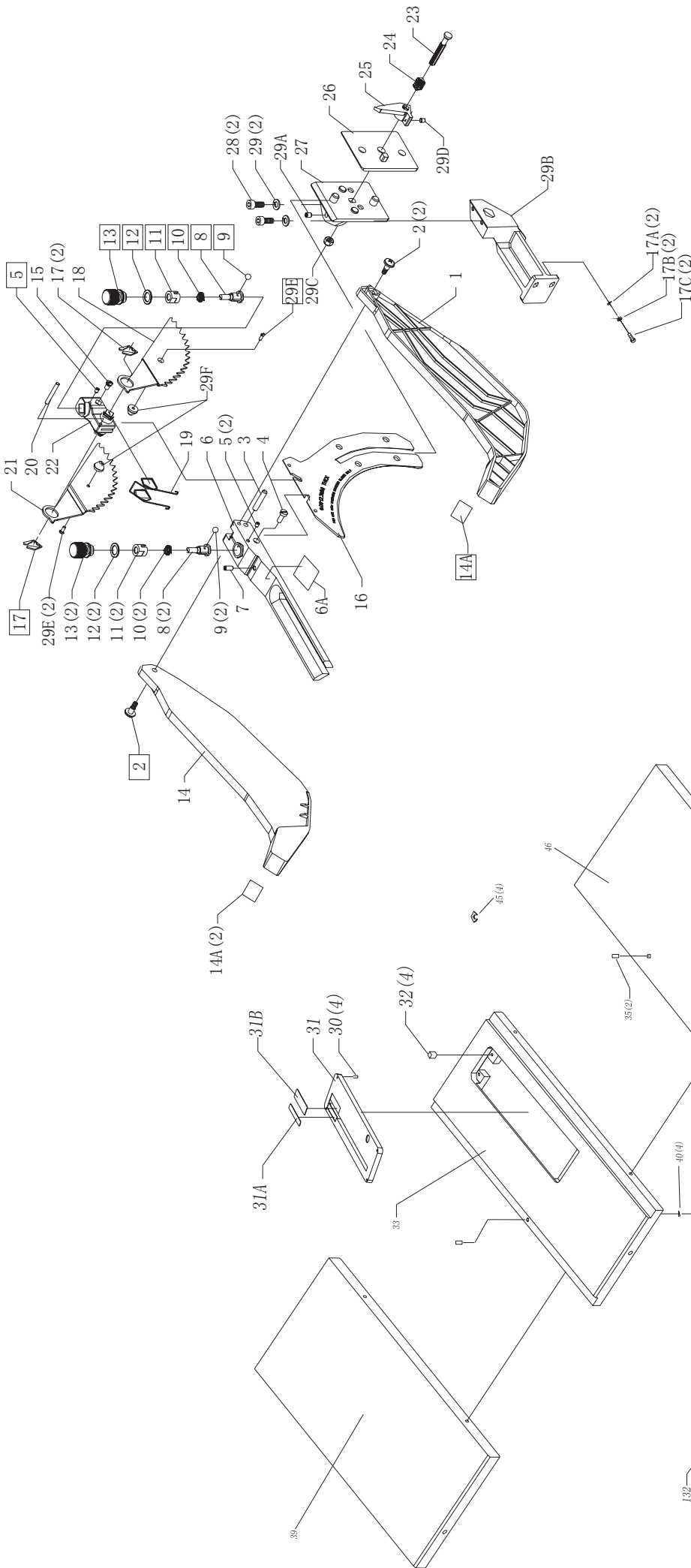

KEY NO.	PART NO.	DESCRIPTION	QTY
1	SC10464	RIGHT BLADE GUARD	1
2	SC10465	SHOULDERED SCR	2
3	SC10466	ROUND PIN	2
4	SC80439	M4X10mm ROUND HD CUTTING SCR	1
5	SC80318	M4X6mm HEX SOC SET SCR W/FLAT POINT	2
6	SC10467	BLADE GUARD SUPPORT ARM	1
6A	SC76039	WARNING LABEL	1
7	SC80319	M5X12mm HEX SOC SET SCR W/CONE POINT	1
8	SC10468	FIXED SHAFT	2
9	SC10469	7/32 STEEL BALL	2
10	SC10470	SPRING	2
11	SC10471	BUSH	2
13	SC10472	TWIST GRIP	2
14	SC10473	LEFT BLADE GUARD	1
14A	SC76040	WARNING LABEL	2
15	OR95116	M4X8mm COUNTERSUNK HD SCR	1
16	SC10474	RIVING KNIFE	1
17	OR94197	∅ 12 RETAINING RING EXTERNAL	2
17A	OR90059	WASHER FLAT M6	2
17B	OR90502	WASHER LOCK M6	2
17C	OR93374	SCR HEX SOC HD M6 X 20mm	2
18	SC10475	RIGHT ANTI KICKBACK FIGURE	1
19	SC10476	TWIST SPRING	1
20	SC84302	∅ 3X30mm SPRING PIN	1
21	SC10477	LEFT ANTI KICKBACK FIGURE	1
22	SC10478	ANTI KICKBACK FINGER SUPPORT	1
23	SC10479	SPECIAL BOLT	1
24	SC10480	SPRING	1
25	SC10481	FAST NUT BASE	1
26	SC10482	RIVING KNIFE PLATE	1
27	SC10483	RIVING KNIFE SUPPORT	1
28	OR93372	SCR SOC HD CAP M6 X 12mm	2
29	OR90502	WASHER LOCK M6	2
29A	SC80321	M6X8mm HEX SOC HD SCR WITH FLAT POINT	1
29B	SC10551	SPLITTER MOUNT SUPPORT	1
29C	SC81113	M8 BLOCKING NUT(LEFT)	1
29D	SC80322	M5X10mm HEX SOC HD SCR WITH FLAT POINT	1
29E	SC80437	ST2.9X6.5 CROSS COUNTERSUNK TAP SCR	2
29F	SC10484	ANTI KICKBACK FINGER SUPPORT BEARER	2
30	OR91789	SCR SET 1/4-28 X 3/8", NYLOK	4
31	SC10486	TABLE INSERT	1
31A	SC10154	TABLE INSERT LEFT PAD	1
31B	SC10155	TABLE INSERT RIGHT PAD	1
32	SC10487	MAGNET FOR 35963/35964	4

35971/35972 TABLE AND EXTENSION WING ASSEMBLY

33	SC10443	TABLE	1
35	SC80428	M8x12mm HEX SOC SET SCR	2
36	SC82114	SPECIAL WASHER(8.3x25x3.5)	8
37	OR90248	WASHER LOCK M8	8
38	SC80429	5/16-18x42mm HEX SOC SET SCR	8
39	SC10444	LEFT GRANITE EXTENSION WING	1
40	SC82117	SPECIAL WASHER(8.5x20x2)	4
41	OR90248	WASHER LOCK M8	4
42	SC80430	5/16-18x28mm HEX SOC SET SCR	4
45	SC10457	MICRO ADJUST FLAT WASHER	4
46	SC10445	RIGHT GRANITE EXTENSION WING	1

KEY NO.	PART NO.	DESCRIPTION	QTY
35963/35964 TABLE AND EXTENSION WING ASSEMBLY			
33	SC10552	TABLE	1
35	SC80428	M8X12 HEX SO SET SREW	2
36	SC82114	M8 FLAT WASHER (8.3X25X3.5)	4
37	OR90248	WASHER LOCK M8	4
38	SC80429	5/16-18 X42mm HEX SO SET SCR	4
39	SC10553	LEFT EXTENSION WING	1
40	SC82117	M8 SPECIAL WASHER(8.5x20x2)	4
41	OR90248	WASHER LOCK M8	4
42	SC80430	5/16-18X28mmHEX SO HD SCR	4
45	SC10457	MIRO ADJUST FLAT WASHER	4
46	SC10554	RIGHT EXTENSION WING	1
60	OR91040	SWITCH PADDLE	1
61	SC80411	M4 x 25mm ROUND HD TAP SCREW	2
62A	OR90343	PUSH BUTTON SWITCH	1
63	OR91043	SWITCH BOX	1
63A	OR91579	SWITCH RESET LABEL	1
64	SC80410	M4 x 16mm ROUND HD TAP SCREW	4
66	OR91062	SWITCH SUPPORT	1
67	SC80104	M6 x 10mm HEX HD SCREW	2
68	OR90381	NUT HEX M5	2
69	OR90362	WASHER EXT TOOTH M5	2
70	OR90505	SCR PAN HD M5 X 12mm	2
73	OR70139	RESET SWITCH (25Amp,125/250V)	1
74	OR91032	JUMPER WIRE	1
75	OR91007	CORD W/FEMALE DISCONNECTOR	1
75A	OR70141	STRAIN RELIEF(7P-2)	2
76	OR91030	POWER CORD	1
*	SC10160	MITER GAUGE ASSY (#114~#132)	1
114	OR91076	MITER GAGE BODY	1
115	SC10161	SPECIAL WASHER	3
116	SC10162	SPECIAL SCREW	2
119	SC10163	GUIDE BAR	1
120	OR91763	SCR HEX SOC SET M4 X 16mm	4
121	OR91783	PIN 1/4" X 3/4"	1
122	OR91774	SCR PAN HD M4 X 10mm	2
122A	OR90143	WASHER FLAT M4	2
123	OR91080	PLUNGER	1
124	OR91081	PLUNGER BLOCK	1
125	OR91082	CURSOR	1
126	OR91775	SCR PAN HD M4 X 15mm	1
127	OR94404	SCR PAN HD M4 X 20mm	3
127A	OR90078	NUT HEX M4	3
130	OR91573	MITER SCALE	1
131	OR91084	WASHER SPECIAL, MITER HANDLE	1
132	SC10153	MITER GAGE KNOB	1

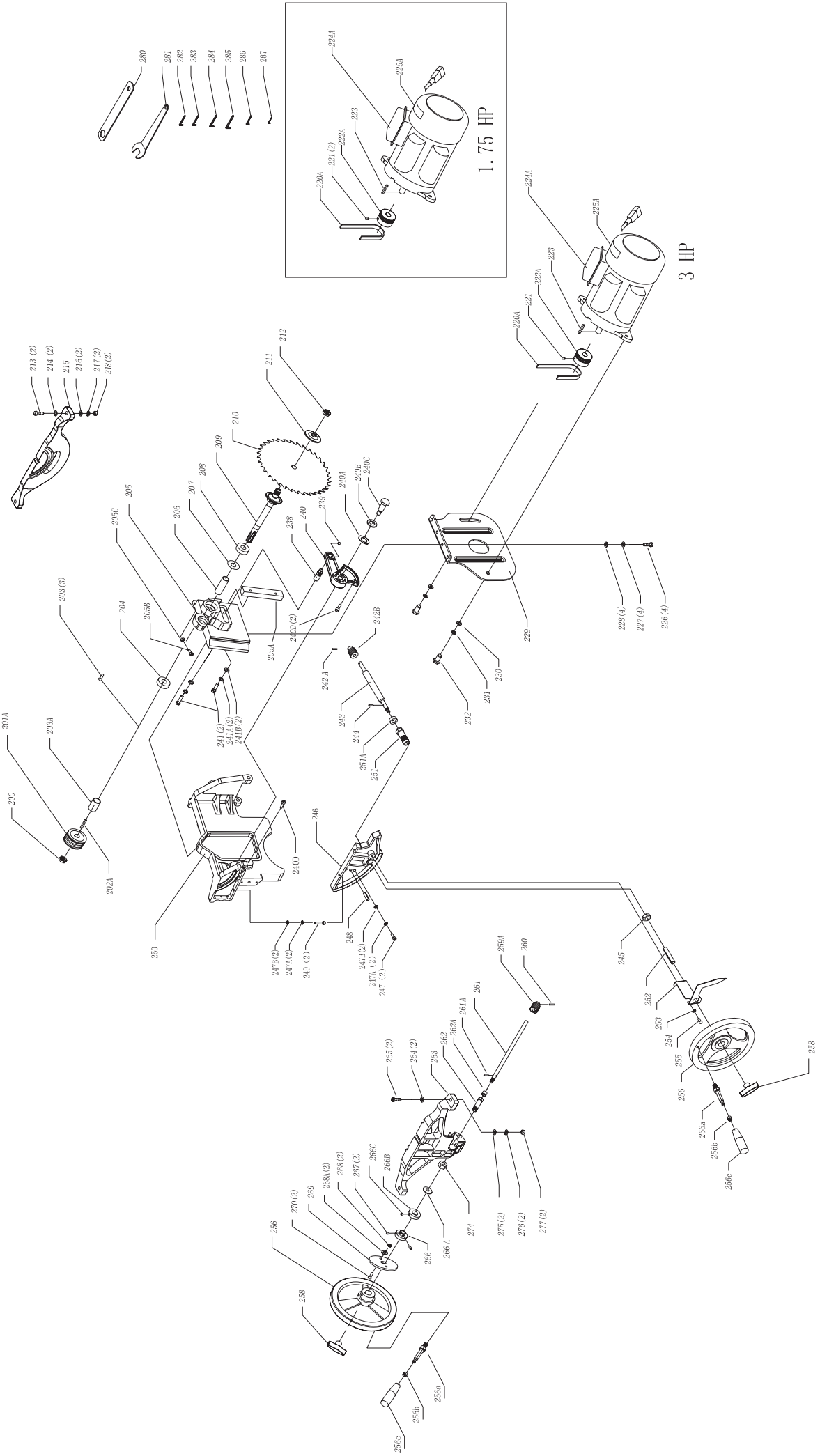

KEY NO.	PART NO.	DESCRIPTION	QTY	KEY NO.	PART NO.	DESCRIPTION	QTY
200	OR91767	NUT L.H. JAM 5/8-18	1	243	SC10195	ELEVATING SHAFT	1
201	OR91020	ARBOR PULLEY	1	244	OR91795	PIN SPRING 4mm X 22mm	1
202	OR91824	KEY 5mm X 5mm X 15mm	1	245	SC10192	HEX NUT	1
203	OR92137	SCR PAN HD M5 X 12mm	3	246	SC10193	FRONT TRUNNION	1
203A	OR91732	ARBOR SPACER (35971/35963)	1	247	OR93374	SCR HEX SOC HD M6 X 20mm	2
203A	OR70144	ARBOR SPACER (35972/35964)	1	247A	OR90509	WASHER LOCK M6	4
204	OR94851	BALL BEARING 6004 2Z	1	247B	OR90529	WASHER FLAT M6	4
205	SC10446	ARBOR RAISING SUPPORT BRACKET	1	248	SC84003	SPRING PIN 8 x 30mm	1
205A	SC10189	GIB	1	249	OR93374	SCR HEX SOC HD M6 X 20mm	2
205B	OR94541	SCR HEX HD M5 X 25mm	2	250	SC10190	MAIN TRUNNION	1
205C	OR90799	NUT HEX M5	2	251	SC10198	RAISE/LOWER SLEEVE	1
206	SC10182	ARBOR SLEEVE	1	251A	SC10555	SPECIAL SLEEVE	1
207	SC82701	WAVE WASHER 6004	1	252	SC10199	RAISE/LOWER SPACER	1
208	OR94851	BALL BEARING 6004 2Z	1	253	SC10200	POINTER	1
209	SC10183	ARBOR SHAFT	1	254	OR90529	WASHER FLAT M6	1
210	OR70400	BLADE(OD:10", ID: 5/8", TEETH: 40)	1	255	OR91826	SCR PAN HD M6 X 16mm	1
211	OR91026	BLADE FLANGE	1	256	SC10202	HANDWHEEL	2
213	OR91746	SCR HEX HD M10 X 45mm	2	256a	SC10204	INSERT HANDLE	2
214	OR94231	WASHER FLAT M10	2	256b	SC10205	HANDLE LOCK	2
215	SC10447	REAR BRAKET	1	256c	SC10206	HANDLE SLEEVE	2
216	OR94231	WASHER FLAT M10	2	258	SC10203	HANDWHEEL LOCK KNOB	2
217	OR90227	WASHER LOCK M10	2	*	SC10177	TILT SHAFT ASSEMBLY(#259-#261)	1
218	OR90228	NUT HEX M10	2	259	SC10179	WORM GEAR	1
220A	SC10438	BELT (6PJ750 L=29.5")(35963/35971)	1	260	SC84005	SPRING PIN 4 x 20mm	1
220A	OR70147	BELT (29.5",6Rib K)(35964/35972)	1	261	SC10178	TILT SHAFT	1
221	SC80409	1/4-20 x 3/8" ROUND HD TAP SCREW	2	261A	OR91795	PIN SPRING 4mm X 22mm	1
222A	OR91023	MOTOR PULLEY(35963/35971)	1	262	OR91738	ECCENTRIC SCR	1
222A	OR70148	MOTOR PULLEY(35964/35972)	1	262A	SC10176	SLEEVE	1
223	OR91770	KEY 5mm X 5mm X 36mm	1	263	SC10449	FRONT BRACKET	1
224A	SC72043	MOTOR ASSY 1.75HP (35963/35971)	1	264	OR94231	WASHER FLAT M10	2
224A	SC72041	MOTOR ASSY 3HP (35964/35972)	1	265	OR91746	SCR HEX HD M10 X 45mm	2
225A	SC76014	MOTOR LABEL 1.75HP(35963/35971)	1	266	OR91018	TILT COLLAR	1
225A	SC76015	MOTOR LABEL 3HP(35964/35972)	1	266A	SC82702	3/8" FIBER WASHER (t=2mm)	1
226	OR93381	SCR HEX SOC HD M8 X 20mm	4	266B	OR91137	COLLAR	1
227	OR90248	WASHER LOCK M8	4	266C	OR91762	SCR HEX SOC SET 1/4-20 X 1/4"	2
228	OR94207	WASHER FLAT M8	4	267	OR91816	SCR HEX SOC SET M6 X 8mm	2
229	SC10450	MOTOR SUPPORT BRACKET	1	268	OR90381	NUT HEX M5	2
230	OR94231	WASHER FLAT M10	2	268A	SC82112	M5 FLAT WASHER (5.4 x 18 x 3)	2
231	OR90227	WASHER LOCK M10	2	269	OR91017	TILT BRACKET	1
232	SC80432	M10X25 HEX HD SCR	2	270	SC80413	M5 x 25mm ROUND HD SCREW	2
238	SC10187	ELEVATION PIN	1	274	OR91768	NUT JAM 9/16-18	1
239	OR93552	SCR HEX SOC SET M6 X 8mm	1	275	OR94231	WASHER FLAT M10	2
240	SC10188	ELEVATING BRACKET	1	276	OR90227	WASHER LOCK M10	2
240A	SC10184	WAVE WASHER	1	277	OR90228	NUT HEX M10	2
240B	SC10185	SPECIAL FLAT WASHER	1	280	OR91726	WRENCH BOX END	1
240C	SC10186	ELEVATING PIVOT BOLT	1	281	OR91727	WRENCH OPEN END	1
240D	SC80104	M6 x 10mm HEX HD SCREW	2	282	OR90289	WRENCH HEX 2.5 mm	1
241	OR90308	SCR HEX HD M8 X 30mm	2	283	OR90290	WRENCH HEX 3mm	1
241A	OR90248	WASHER LOCK M8	2	284	OR90291	WRENCH HEX 4mm	1
241B	OR94207	WASHER FLAT M8	2	285	OR91728	WRENCH HEX 5mm	1
242A	SC84005	SPRING PIN 4 x 20mm	1	286	OR92172	WRENCH HEX 6mm	1
242B	SC10194	WORM GEAR	1	287	OR91808	WRENCH ALLEN 1/8"	1

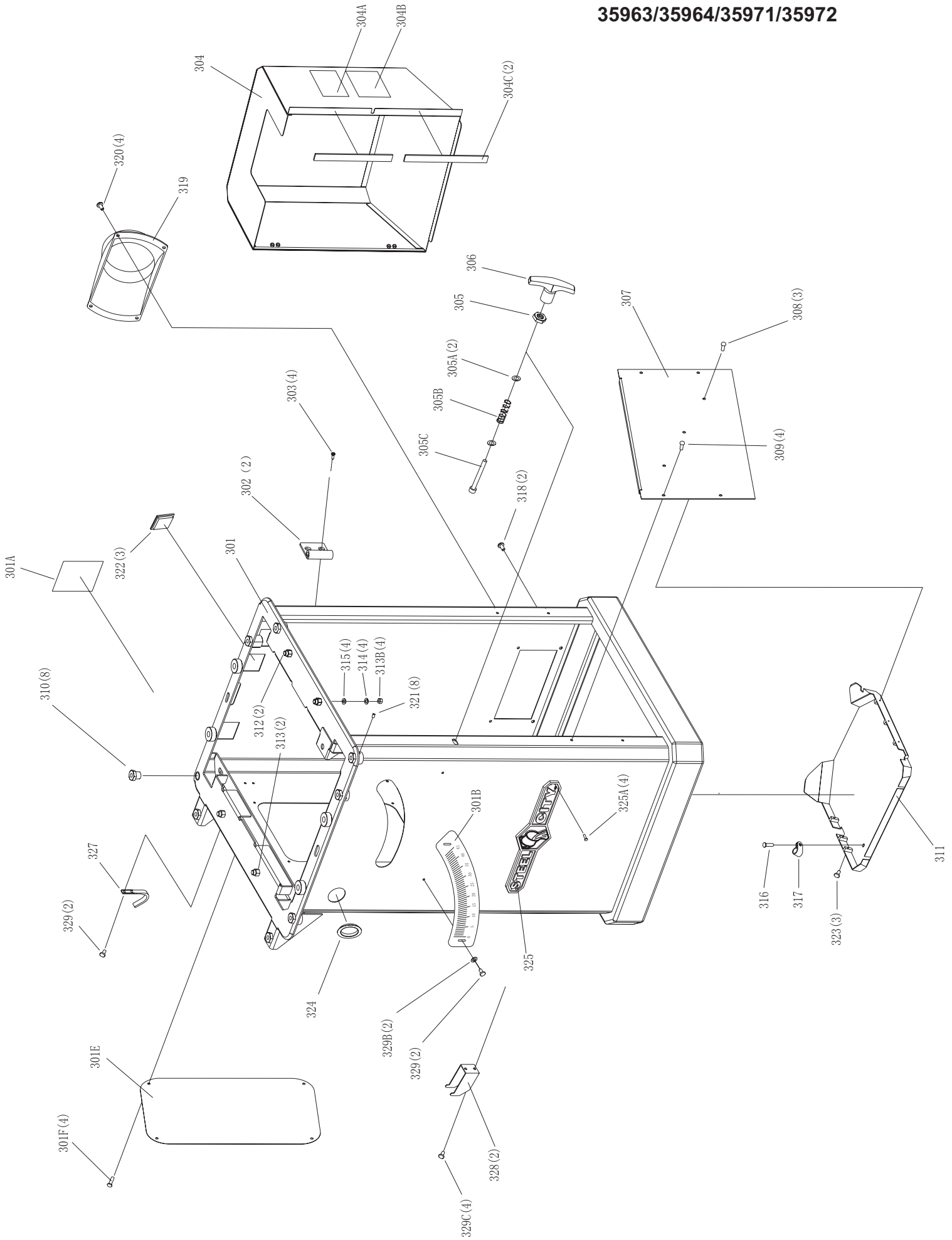

KEY NO.	PART NO.	DESCRIPTION	QTY
301	SC10451	CABINET ASSY WELDMENT(35971/35972)	1
301	SC10556	CABINET ASSY WELDMENT(35963/35964)	1
301A	SC76046	SPEC LABEL(35971)	1
301A	SC76047	SPEC LABEL(35963)	1
301A	SC76048	SPEC LABEL(35964)	1
301A	SC76034	SPEC LABEL(35972)	1
301B	OR70160	BEVEL SCALE	1
301E	SC10218	CABINET ACCESS DOOR	1
301F	SC80406	M4 x 8mm PAN HD TAP SCREW	4
302	SC10452	HINGE ASSY	2
303	SC80409	1/4-20 x 3/8" ROUND HD TAP SCREW	4
304	SC10453	MOTOR COVER-machine	1
304A	SC10212	WARNING LABEL	1
304B	SC10215	WARNING LABEL	1
304C	SC76036	SPONGE	2
305	SC81102	5/16-24 HEX NUT	1
305A	OR94207	WASHER FLAT M8	2
305B	SC10216	SPRING	1
305C	SC80106	5/16-24 x 2" HEX HD SCR	1
306	SC10213	KNOB	1
307	OR70165	CABINET SIDE PANEL	1
308	SC80409	1/4-20 x 3/8" ROUND HD TAP SCR	3
309	SC80409	1/4-20 x 3/8" ROUND HD TAP SCR	4

KEY NO.	PART NO.	DESCRIPTION	QTY
310	SC10454	ADJUSTMENT SCREW	8
311	OR91124	DUST CHUTE	1
312	SC10455	FIXING PIN	2
313	SC10557	SPECIAL LOCATION PIN	2
313B	OR90307	NUT HEX M8	4
314	OR90248	WASHER LOCK M8	4
315	OR94207	WASHER FLAT M8	4
316	SC80409	1/4-20 x 3/8" ROUND HD TAP SCR	1
317	OR91737	CABLE CLAMP	1
318	SC80409	1/4-20 x 3/8" ROUND HD TAP SCREW	2
319	OR91128	DUST PORT	1
320	SC80408	1/4-20 x 1/2" ROUND HD TAP SCREW	4
321	OR93906	SCR HEX SOC SET M5 X 6mm	8
322	SC10456	END CAP	3
323	SC80409	1/4-20 x 3/8" ROUND HD TAP SCREW	3
324	OR91106	INSULATOR	1
325	OR70484	NAMEPLATE	1
325A	OR93823	RIVET 2 X 8	4
327	OR91134	WRENCH HOOK	1
328	OR91135	FENCE HOOK	1
329	OR91832	SCR TRIANGLE TAP M4 X 8mm	4
329B	OR90143	WASHER FLAT M4	2
329C	SC80409	1/4-20 x 3/8" ROUND HD TAP SCREW	4

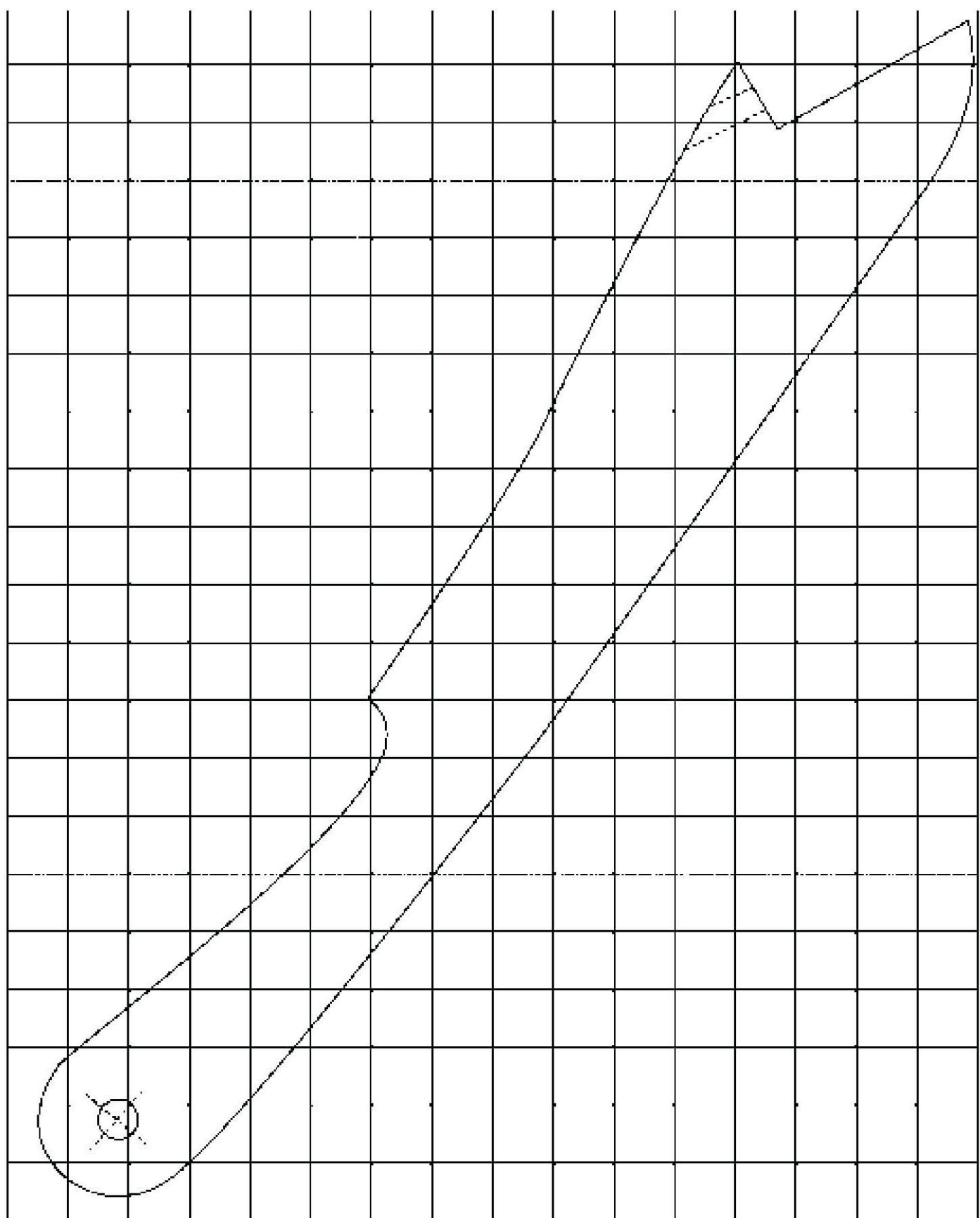



STEEL CITY TOOL WORKS

www.steelcitytoolworks.com

**1-877-SC4-TOOL
(1-877-724-8665)**

5 Year Warranty

