

READ THIS FIRST

Model W1829

IMPORTANT UPDATE

Applies to Models Mfd. Since 8/18
and Owner's Manual Revised 2/18



Phone #: (360) 734-3482 • Tech Support: techsupport@woodstockint.com • Web: www.woodstockint.com

We made the following changes to this machine since the manual was printed:

- Cutterhead guard is stamped steel.
- Knives secure to cutterhead with Torx screws.
- Fence is aluminum, and fence bracket has been modified.

Aside from the information contained in this update, all other content in the owner's manual is applicable and **MUST** be read and understood for your own safety.

IMPORTANT: Keep this update with the owner's manual for future reference. If you have any further questions, contact our Technical Support.

Revised Main Parts

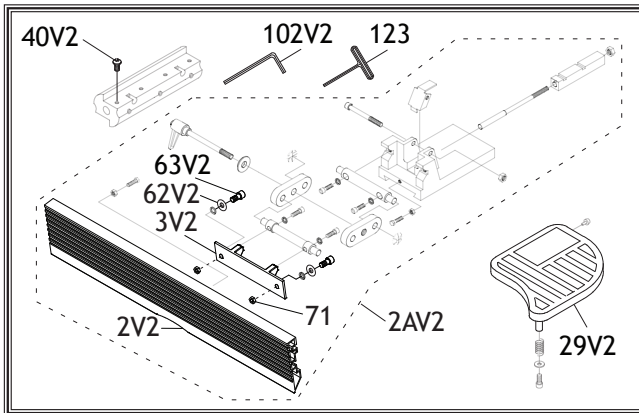

New Cutterhead Guard & Fence

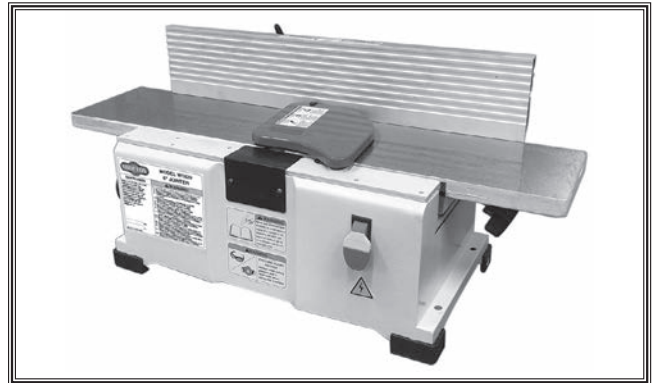

REF	PART #	DESCRIPTION
2AV2	X1829002AV2	FENCE ASSEMBLY V2.08.18
2V2	X1829002V2	FENCE, ALUMINUM V2.08.18
3V2	X1829003V2	FENCE PLATE V2.08.18
29V2	X1829029V2	CUTTERHEAD GUARD V2.08.18
40V2	X1829040V2	FLAT HD TORX SCR 1/4-20 X 5/8 V2.11.18
62V2	X1829062V2	FLAT WASHER 8MM V2.08.18
63V2	X1829063V2	CAP SCREW M8-1.25 X 25 V2.08.18
71	X1829071	HEX NUT M8-1.25
102V2	X1829102V2	HEX WRENCH 5MM V2.08.18
123	X1829123	T-HANDLE TORX DRIVER T-30

Old Cutterhead Guard & Fence

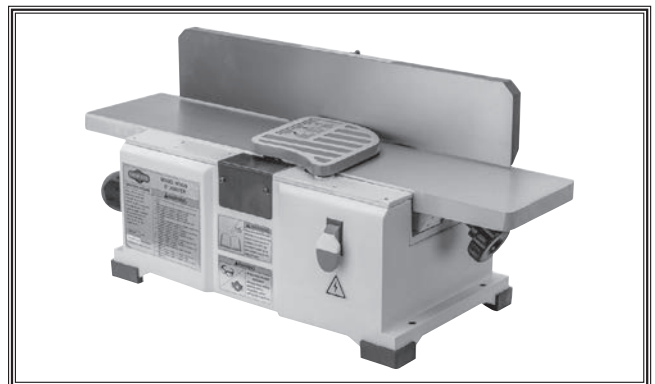

COPYRIGHT © NOVEMBER, 2018 BY WOODSTOCK INTERNATIONAL, INC.

WARNING: NO PORTION OF THIS MANUAL MAY BE REPRODUCED IN ANY SHAPE OR FORM WITHOUT

#19865MN

THE WRITTEN APPROVAL OF WOODSTOCK INTERNATIONAL, INC.

Printed in China

Revised Specifications

Product Dimensions

Weight..... 59 lbs.

Shipping Dimensions

Weight..... 67 lbs.

Construction

Fence..... Aluminum

Cutterhead GuardStamped Steel

Revised Inventory

Jointer Inventory (Figure 5)	Qty
A. Jointer Bed Assembly	1
B. Fence	1
C. Dust Collection Bag.....	1
D. Push Blocks	2
E. Fence Tilting Handle	1
F. Fence Bracket Assembly	1
G. Fence Sliding Handle	1
H. Locking Plate Assembly	1
I. Fence Support.....	1
J. Dust Chute	1
K. Dust Collection Bag Clamp	1
L. Limit Block.....	1
M. Hex Wrench 4mm.....	1
N. Hex Wrench 5mm	1
O. T-Handle Torx Driver T-30	1

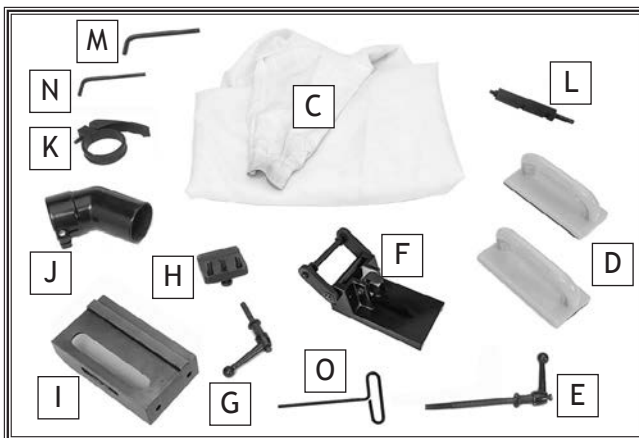

Figure 5. Small components.

Revised Assembly

Please follow the Assembly instructions in your Owner's Manual, beginning on Page 14. Due to changes made to the W1829 fence, **Steps 5 and 8** (shown below) must be substituted for these same steps in the manual.

- Press down on limit plate tab on fence assembly, and insert limit block with notched side facing upward. Use (2) M6-1 x 20 cap screws and (2) 6mm lock washers to attach fence to fence bracket assembly (see Figure 12).

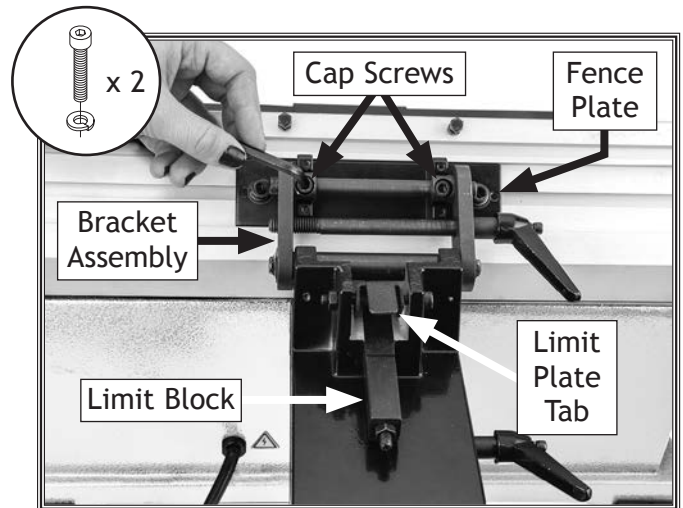

Figure 12. Attaching fence to fence bracket assembly.

- Install the fence tilting handle by threading the handle shaft into the bracket assembly, as shown in Figure 15.

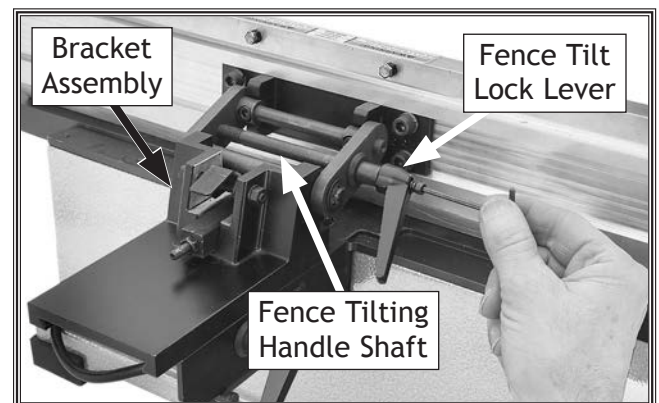

Figure 15. Installing the fence tilting handle.



MODEL W1829 6" JOINTER



OWNER'S MANUAL (FOR MODELS MANUFACTURED SINCE 3/18)

Phone: (360) 734-3482 • Online Technical Support: tech-support@shopfox.biz

COPYRIGHT © SEPTEMBER, 2011 BY WOODSTOCK INTERNATIONAL, INC. REVISED FEBRUARY, 2018 (HE)
WARNING: NO PORTION OF THIS MANUAL MAY BE REPRODUCED IN ANY SHAPE OR FORM WITHOUT
THE WRITTEN APPROVAL OF WOODSTOCK INTERNATIONAL, INC.

#14362KN Printed in China



WARNING!

This manual provides critical safety instructions on the proper setup, operation, maintenance, and service of this machine/tool. Save this document, refer to it often, and use it to instruct other operators.

Failure to read, understand and follow the instructions in this manual may result in fire or serious personal injury—including amputation, electrocution, or death.

The owner of this machine/tool is solely responsible for its safe use. This responsibility includes but is not limited to proper installation in a safe environment, personnel training and usage authorization, proper inspection and maintenance, manual availability and comprehension, application of safety devices, cutting/sanding/grinding tool integrity, and the usage of personal protective equipment.

The manufacturer will not be held liable for injury or property damage from negligence, improper training, machine modifications or misuse.



WARNING!

Some dust created by power sanding, sawing, grinding, drilling, and other construction activities contains chemicals known to the State of California to cause cancer, birth defects or other reproductive harm. Some examples of these chemicals are:

- Lead from lead-based paints.
- Crystalline silica from bricks, cement and other masonry products.
- Arsenic and chromium from chemically-treated lumber.

Your risk from these exposures varies, depending on how often you do this type of work. To reduce your exposure to these chemicals: Work in a well ventilated area, and work with approved safety equipment, such as those dust masks that are specially designed to filter out microscopic particles.

Contents

INTRODUCTION	2	ACCESSORIES	25
Woodstock Technical Support	2	MAINTENANCE	27
About Your Machine	2	General	27
Machine Specifications	4	Cleaning	27
Controls & Features	5	Table & Base	27
SAFETY	6	V-Belts	27
Standard Machinery Safety Instructions	6	Lubrication	27
Additional Safety for Jointers	8	SERVICE	28
ELECTRICAL	9	General	28
Circuit Requirements	9	Troubleshooting	28
Grounding Requirements	10	Checking/Adjusting Knife Height	30
Extension Cords	10	Replacing Knives	32
SETUP	11	Setting Fence Angle Stops	33
Unpacking	11	V-Belt Replacement	36
Inventory	11	Motor Brush Replacement	37
Machine Placement	12	Electrical Safety Instructions	38
Cleaning Machine	12	Wiring Diagram	39
Bench Mounting	13	PARTS	40
Assembly	14	Main	40
Dust Collection	16	Labels	42
Recommended Adjustments	16	WARRANTY	45
Power Connection	17		
Test Run	18		
OPERATIONS	19		
General	19		
Basic Controls	19		
Stock Inspection & Requirements	20		
Squaring Stock	21		
Surface Planing	22		
Edge Jointing	23		
Bevel Cutting	24		

USE THE QUICK GUIDE PAGE LABELS TO SEARCH OUT INFORMATION FAST!





INTRODUCTION

Woodstock Technical Support

This machine has been specially designed to provide many years of trouble-free service. Close attention to detail, ruggedly built parts and a rigid quality control program assure safe and reliable operation.

Woodstock International, Inc. is committed to customer satisfaction. Our intent with this manual is to include the basic information for safety, setup, operation, maintenance, and service of this product.

We stand behind our machines! In the event that questions arise about your machine, please contact Woodstock International Technical Support at (360) 734-3482 or send e-mail to: tech-support@shopfox.biz. Our knowledgeable staff will help you troubleshoot problems and process warranty claims.

If you need the latest edition of this manual, you can download it from <http://www.shopfox.biz>.
If you have comments about this manual, please contact us at:

Woodstock International, Inc.
Attn: Technical Documentation Manager
P.O. Box 2309
Bellingham, WA 98227
Email: manuals@woodstockint.com

About Your Machine

The W1829 6" Jointer is a benchtop machine; its compact size makes for convenient placement in any shop. It mounts and dismounts quickly to a workbench making it portable when necessary.

It is primarily used to produce straight, flat faces on a workpiece, in order to properly square the material for further layout, construction and joining.



MACHINE SPECIFICATIONS



© Woodstock International, Inc. • Phone: (800) 840-8420 • Web: www.shopfox.biz

MODEL W1829 6" BENCHTOP JOINTER

Product Dimensions

Weight..... 76 lbs.
 Width (side-to-side) x Depth (front-to-back) x Height..... 29-1/2 x 19-3/4 x 12-1/2 in.
 Footprint (Length x Width)..... 18-7/8 x 11 in.

Shipping Dimensions

Type..... Cardboard Box
 Content..... Machine
 Weight..... 82 lbs.
 Length x Width x Height..... 32 x 15 x 11 in.

Electrical

Power Requirement..... 110V, Single-Phase, 60 Hz
 Prewired Voltage..... 110V
 Full-Load Current Rating..... 12A
 Minimum Circuit Size..... 15A
 Connection Type..... Cord & Plug
 Power Cord Included..... Yes
 Power Cord Length..... 8 ft.
 Power Cord Gauge..... 16 AWG
 Plug Included..... Yes
 Included Plug Type..... 5-15
 Switch Type..... ON/OFF Push Button Switch w/Large Shut-Off Paddle

Motors

Main

Horsepower..... 1.5 HP
 Phase..... Single-Phase
 Amps..... 12A
 Speed..... 20,000 RPM
 Type..... Universal
 Power Transfer Belt Drive
 Bearings..... Shielded & Permanently Lubricated

Main Specifications

Main Specifications

Bevel Jointing..... 0 - 45 deg. L/R
 Maximum Width of Cut..... 6 in.
 Maximum Depth of Cut..... 1/8 in.
 Minimum Workpiece Length..... 8 in.
 Minimum Workpiece Thickness..... 1/2 in.
 Number of Cuts Per Minute..... 20,000



Fence Information

Fence Length.....	22-7/8 in.
Fence Width.....	3/4 in.
Fence Height.....	4-5/16 in.
Fence Stops.....	45, 90, 135 deg.

Cutterhead Information

Cutterhead Type.....	2 Knife
Cutterhead Diameter.....	1-7/8 in.
Cutterhead Speed.....	10,000 RPM

Knife Information

Number of Knives.....	2
Knife Type.....	HSS, Single-Sided
Knife Length.....	6 in.
Knife Width.....	7/8 in.
Knife Thickness.....	3/32 in.
Knife Adjustment.....	Jack Screws

Table Information

Table Length.....	28-1/2 in.
Table Width.....	6-1/4 in.
Table Thickness.....	1/4 in.
Table Adjustment Type.....	Knob
Table Movement Type.....	Swing

Construction

Base.....	Pre-formed Steel
Body Assembly.....	Pre-formed Steel
Fence Assembly.....	Cast Iron
Guard.....	Aluminum
Table.....	Precision-Ground Cast Iron
Paint Type/Finish.....	Powder Coated

Other Information

Number of Dust Ports.....	1
Dust Port Size.....	2-1/2 in.

Other

Country of Origin	China
Warranty	2 Years
Approximate Assembly & Setup Time	30 Minutes
ISO 9001 Factory	No
Certified by a Nationally Recognized Testing Laboratory (NRTL)	No

Features

- 45 Degree Inward, 90 and 45 Degree Outward Stops
- Jack Screw Knife Adjustment
- 2-1/2" Dust Port
- 2 Safety Push Blocks
- Dust Collection Fan, Chute and Bag

Controls & Features

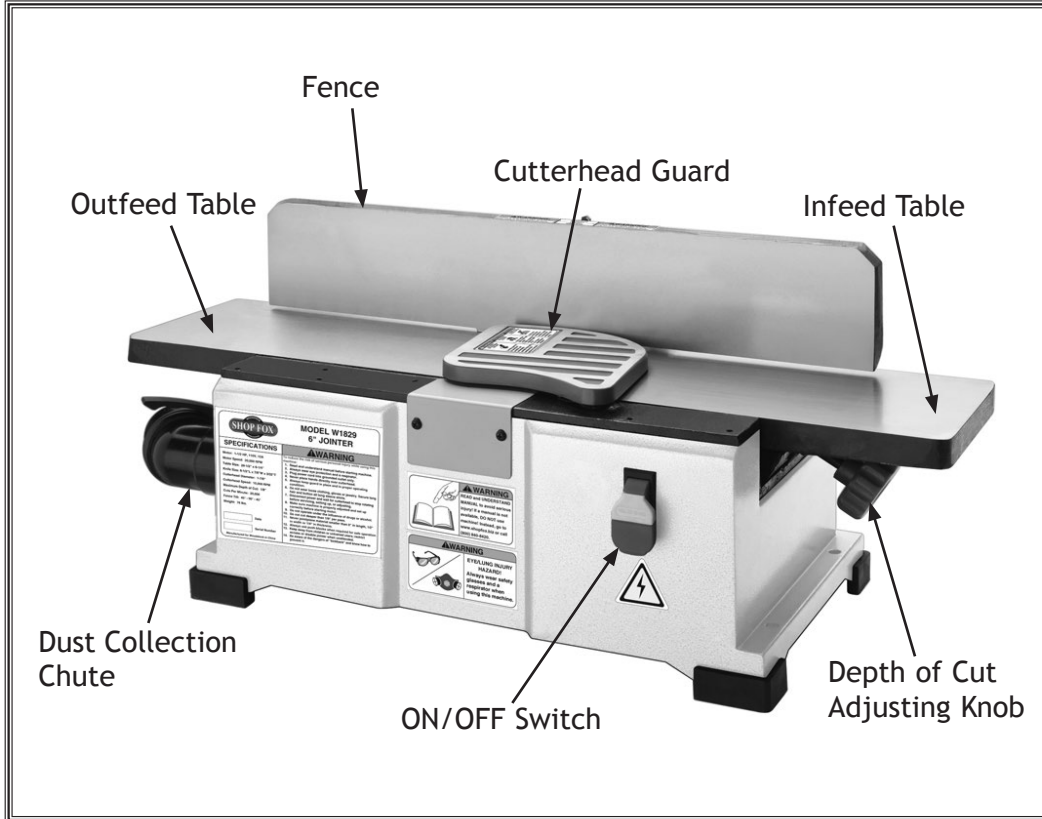

Figure 1. W1829 identification—front view.

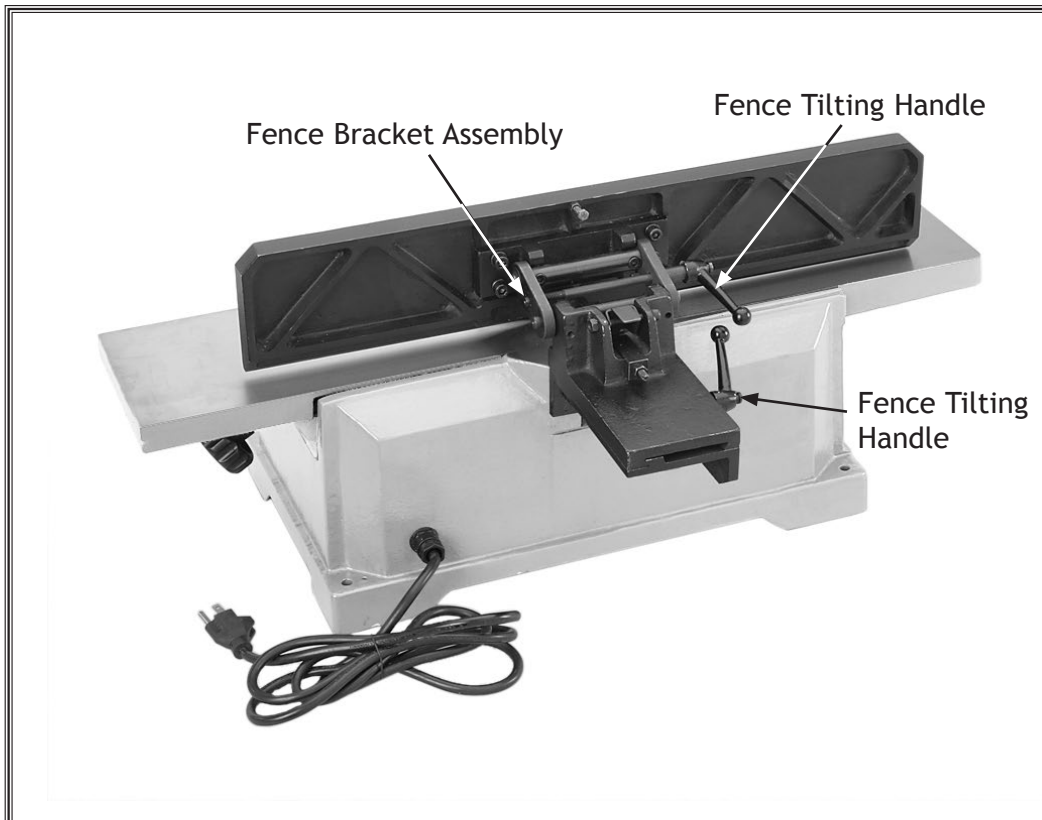

Figure 2. W1829 identification—rear view.

SAFETY

**READ MANUAL BEFORE OPERATING MACHINE.
FAILURE TO FOLLOW INSTRUCTIONS BELOW WILL
RESULT IN PERSONAL INJURY.**

DANGER

Indicates an imminently hazardous situation which, if not avoided, **WILL** result in death or serious injury.

WARNING

Indicates a potentially hazardous situation which, if not avoided, **COULD** result in death or serious injury.

CAUTION

Indicates a potentially hazardous situation which, if not avoided, **MAY** result in minor or moderate injury.

NOTICE

This symbol is used to alert the user to useful information about proper operation of the equipment, and/or a situation that may cause damage to the machinery.

Standard Safety Instructions

1. **READ THROUGH THE ENTIRE MANUAL BEFORE STARTING MACHINERY.** Machinery presents serious injury hazards to untrained users.
2. **ALWAYS USE ANSI APPROVED SAFETY GLASSES WHEN OPERATING MACHINERY.** Everyday eye-glasses only have impact resistant lenses—they are **NOT** safety glasses.
3. **ALWAYS WEAR A NIOSH APPROVED RESPIRATOR WHEN OPERATING MACHINERY THAT PRODUCES DUST.** Wood dust is a carcinogen and can cause cancer and severe respiratory illnesses.
4. **ALWAYS USE HEARING PROTECTION WHEN OPERATING MACHINERY.** Machinery noise can cause permanent hearing damage.
5. **WEAR PROPER APPAREL.** **DO NOT** wear loose clothing, gloves, neckties, rings, or jewelry which may get caught in moving parts. Wear protective hair covering to contain long hair and wear non-slip footwear.
6. **NEVER OPERATE MACHINERY WHEN TIRED, OR UNDER THE INFLUENCE OF DRUGS OR ALCOHOL.** Be mentally alert at all times when running machinery.
7. **ONLY ALLOW TRAINED AND PROPERLY SUPERVISED PERSONNEL TO OPERATE MACHINERY.** Make sure operation instructions are safe and clearly understood.
8. **KEEP CHILDREN AND VISITORS AWAY.** Keep all children and visitors a safe distance from the work area.
9. **MAKE WORKSHOP CHILD PROOF.** Use padlocks, master switches, and remove start switch keys.

10. **NEVER LEAVE WHEN MACHINE IS RUNNING.** Turn power **OFF** and allow all moving parts to come to a complete stop before leaving machine unattended.
11. **DO NOT USE IN DANGEROUS ENVIRONMENTS.** DO NOT use machinery in damp, wet locations, or where any flammable or noxious fumes may exist.
12. **KEEP WORK AREA CLEAN AND WELL LIT.** Clutter and dark shadows may cause accidents.
13. **USE A GROUNDED EXTENSION CORD RATED FOR THE MACHINE AMPERAGE.** Undersized cords over-heat and lose power. Replace extension cords if they become damaged. DO NOT use extension cords for 220V machinery.
14. **ALWAYS DISCONNECT FROM POWER SOURCE BEFORE SERVICING MACHINERY.** Make sure switch is in OFF position before reconnecting.
15. **MAINTAIN MACHINERY WITH CARE.** Keep blades sharp and clean for best and safest performance. Follow instructions for lubricating and changing accessories.
16. **MAKE SURE GUARDS ARE IN PLACE AND WORK CORRECTLY BEFORE USING MACHINERY.**
17. **REMOVE ADJUSTING KEYS AND WRENCHES.** Make a habit of checking for keys and adjusting wrenches before turning machinery **ON**.
18. **CHECK FOR DAMAGED PARTS BEFORE USING MACHINERY.** Check for binding and alignment of parts, broken parts, part mounting, loose bolts, and any other conditions that may affect machine operation. Repair or replace damaged parts.
19. **USE RECOMMENDED ACCESSORIES.** Refer to the instruction manual for recommended accessories. The use of improper accessories may cause risk of injury.
20. **DO NOT FORCE MACHINERY.** Work at the speed for which the machine or accessory was designed.
21. **SECURE WORKPIECE.** Use clamps or a vise to hold the workpiece when practical. A secured workpiece protects your hands and frees both hands to operate the machine.
22. **DO NOT OVERREACH.** Keep proper footing and balance at all times.
23. **MANY MACHINES WILL EJECT THE WORKPIECE TOWARD THE OPERATOR.** Know and avoid conditions that cause the workpiece to "kickback."
24. **ALWAYS LOCK MOBILE BASES (IF USED) BEFORE OPERATING MACHINERY.**
25. **BE AWARE THAT CERTAIN DUST MAY BE HAZARDOUS** to the respiratory systems of people and animals, especially fine dust. Make sure you know the hazards associated with the type of dust you will be exposed to and always wear a respirator approved for that type of dust.

Additional Safety for Jointers

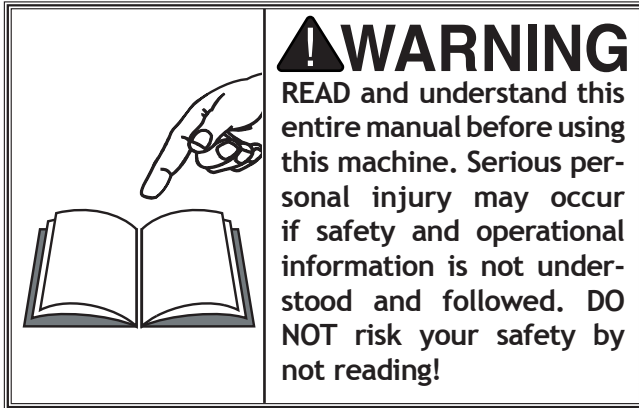

JOINTER KICKBACK. "Kickback" is when the workpiece is thrown off the jointer table by the force of the cutterhead. Always use push blocks and safety glasses to reduce the likelihood of injury from "kickback." If you do not understand what kickback is, or how it occurs, **DO NOT** operate this machine.

CUTTERHEAD ALIGNMENT. Keep the edge of the cutterhead knives at top dead center (TDC) even with the top edge of the outfeed table to avoid kickback and personal injuries.

WORKPIECE SUPPORT. Supporting the workpiece adequately at all times while jointing is crucial for making safe cuts and avoiding injury. Never attempt to make a cut with an unstable workpiece.

PUSH BLOCKS. Always use push blocks whenever surface planing. Never pass your hands directly over the cutterhead without a push block.

KICKBACK ZONE. The "kickback zone" is the path directly through the end of the infeed table. Never stand or allow others to stand in this area during operation.

MAXIMUM CUTTING DEPTH. The maximum cutting depth for one pass is $\frac{1}{8}$ ". Never attempt any single cut deeper than this!

JOINTING WITH THE GRAIN. Jointing against the grain or jointing end grain is dangerous and could produce chatter or excessive chip out. Always joint with the grain.

CUTTERHEAD GUARD. All operations must be performed with the cutterhead guard in place. Always ensure that the cutterhead guard is in proper working condition before operating the jointer.

PROPER CUTTING. When cutting, always keep the workpiece moving toward the outfeed table until the workpiece has passed completely over the cutterhead. Never back the work toward the infeed table.

USING GOOD STOCK. Jointing safety begins with the choice of stock. Inspect your stock carefully before feeding it over the cutterhead. Never joint a board that has loose knots, nails, or staples. If you have any doubts about the stability or structural integrity of your stock, **DO NOT** joint it!

EXPERIENCING DIFFICULTIES. If at any time you are experiencing difficulties performing the intended operation, stop using the machine! Contact Tech Support at (360) 734-3482.

ELECTRICAL

Circuit Requirements

This machine must be connected to the correct size and type of power supply circuit, or fire or electrical damage may occur. Read through this section to determine if an adequate power supply circuit is available. If a correct circuit is not available, a qualified electrician **MUST** install one before you can connect the machine to power.

A power supply circuit includes all electrical equipment between the breaker box or fuse panel in the building and the machine. The power supply circuit used for this machine must be sized to safely handle the full-load current drawn from the machine for an extended period of time. (If this machine is connected to a circuit protected by fuses, use a time delay fuse marked D.)

Full-Load Current Rating

The full-load current rating is the amperage a machine draws at 100% of the rated output power. On machines with multiple motors, this is the amperage drawn by the largest motor or sum of all motors and electrical devices that might operate at one time during normal operations.

Full-Load Current Rating at 110V 12 Amps

Circuit Requirements for 110V

This machine can be converted to operate on a 110V power supply (details about voltage conversion can be found later in this manual). The 110V power supply circuit must have a verified ground and meet the requirements that follow:

- Circuit Type 110V/120V, 60 Hz, Single-Phase
- Circuit Size 15 Amps
- Plug/Receptacle NEMA 5-15

⚠ WARNING

The machine must be properly set up before it is safe to operate. **DO NOT** connect this machine to the power source until instructed to do later in this manual.

⚠ WARNING



Incorrectly wiring or grounding this machine can cause electrocution, fire, or machine damage. To reduce this risk, only an electrician or qualified service personnel should do any required electrical work on this machine.

Note: The circuit requirements listed in this manual apply to a dedicated circuit—where only one machine will be running at a time. If this machine will be connected to a shared circuit where multiple machines will be running at the same time, consult a qualified electrician to ensure that the circuit is properly sized for safe operation.

ELECTRICAL

Grounding Requirements

This machine **MUST** be grounded. In the event of certain types of malfunctions or breakdowns, grounding provides a path of least resistance for electric current to travel—in order to reduce the risk of electric shock.

Improper connection of the equipment-grounding wire will increase the risk of electric shock. The wire with green insulation (with/without yellow stripes) is the equipment-grounding wire. If repair or replacement of the power cord or plug is necessary, do not connect the equipment-grounding wire to a live (current carrying) terminal.

Check with a qualified electrician or service personnel if you do not understand these grounding requirements, or if you are in doubt about whether the tool is properly grounded. If you ever notice that a cord or plug is damaged or worn, disconnect it from power, and immediately replace it with a new one.

For 110V Connection

A NEMA 5-15 plug has a grounding prong that must be attached to the equipment-grounding wire inside the included power cord. The plug must only be inserted into a matching receptacle (see **Figure 3**) that is properly installed and grounded in accordance with all local codes and ordinances.

Extension Cords

We do not recommend using an extension cord with this machine. Extension cords cause voltage drop, which may damage electrical components and shorten motor life. Voltage drop increases with longer extension cords and smaller gauge sizes (higher gauge numbers indicate smaller sizes).

Any extension cord used with this machine must contain a ground wire, match the required plug and receptacle, and meet the following requirements:

- Minimum Gauge Size at 110V 14 AWG**
- Maximum Length (Shorter is Better)..... 50 ft.**

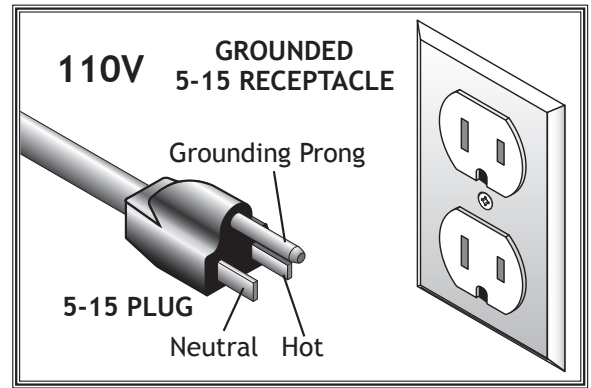
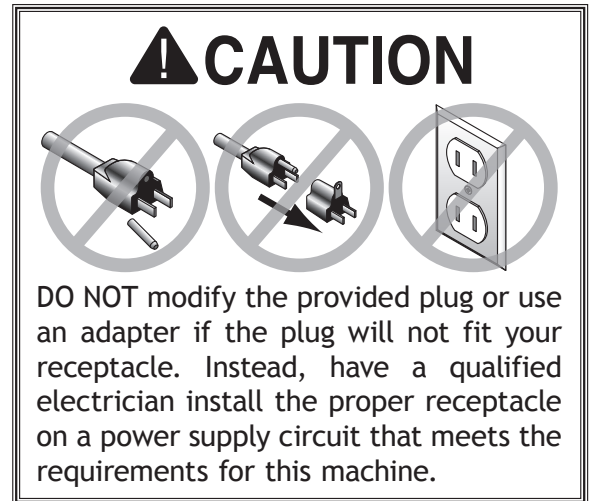

Figure 3. NEMA 5-15 plug & receptacle.



ELECTRICAL

SETUP

Unpacking

This machine has been carefully packaged for safe transportation. If you notice the machine has been damaged during shipping, please contact your authorized Shop Fox dealer immediately.

Inventory

The following is a description of the main components shipped with the Model W1829. Lay the components out to inventory them.

Note: If you can't find an item on this list, check the mounting location on the machine or examine the packaging materials carefully. Occasionally we pre-install certain components for safer shipping.

Jointer Inventory: (Figures 4-5)	Qty
A. Jointer Bed Assembly	1
B. Fence	1
C. Dust Collection Bag	1
D. Push Blocks	2
E. Fence Tilting Handle	1
F. Fence Bracket Assembly	1
G. Fence Sliding Handle	1
H. Locking Plate Assembly	1
I. Fence Support	1
J. Dust Chute	1
K. Dust Collection Bag Clamp	1

Hardware and Tools (Not shown)

–Cap Screws M8-1.25 x 20	6
–Lock Washers 8mm	6
–Hex Wrench 4mm	1
–Hex Wrench 6mm	1

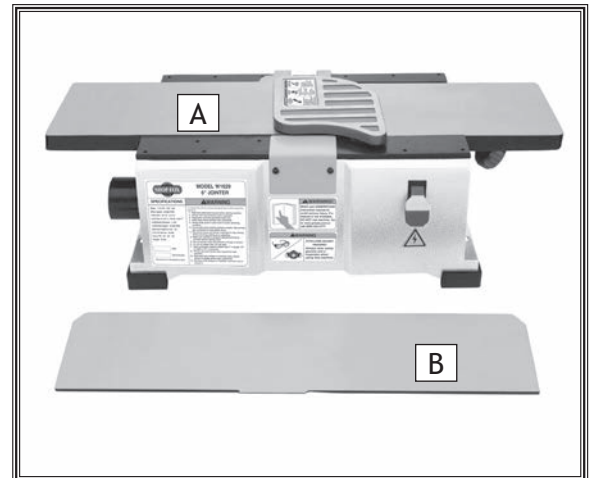
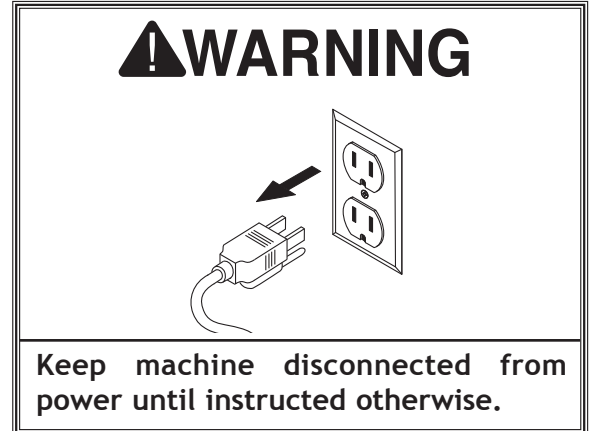

Figure 4. Large components.

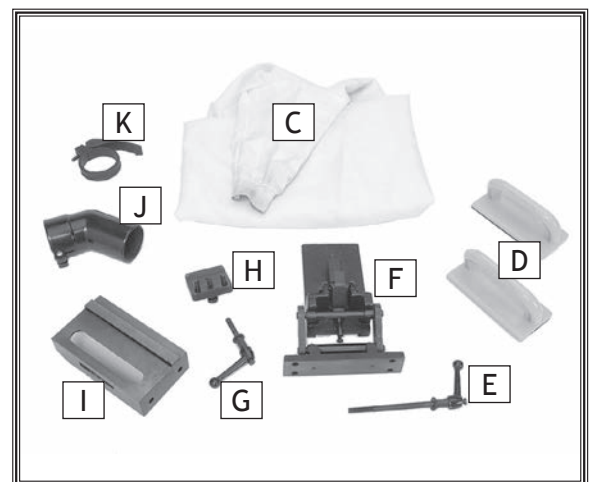

Figure 5. Small components.

SETUP

Machine Placement

- **Workbench Load:** Refer to the **Machine Specifications**, on **Page 3**, for the weight and footprint specifications of your machine. Some workbenches may require additional reinforcement to support both the weight of the machine and materials.
- **Working Clearances:** Consider the size of material to be processed through the machine, space for auxiliary stands, work tables and other machinery when establishing a location for your Jointer. See **Figure 6** for the overall machine measurements.

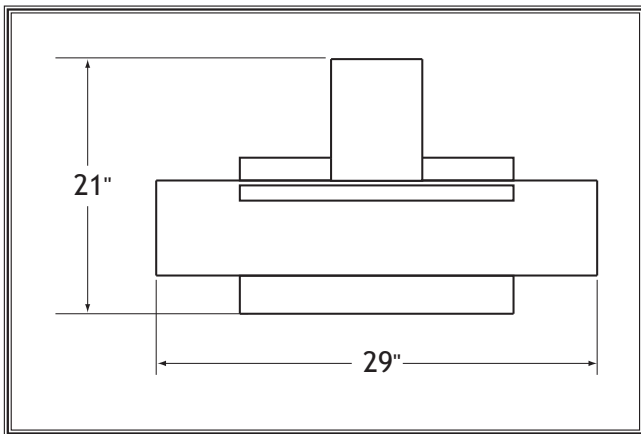

Figure 6. Machine dimensions.



⚠️ WARNING
 USE helpers or power lifting equipment to lift this 6" Jointer. Otherwise, serious personal injury may occur.



⚠️ CAUTION
 MAKE your shop "child safe." Close and lock all entrances when you are away. NEVER allow untrained visitors in your shop when assembling, adjusting or operating equipment.

Cleaning Machine

The tables and other unpainted parts of your jointer are coated with a waxy grease that protects them from corrosion during shipment. Clean this grease off with a solvent cleaner or citrus-based degreaser. DO NOT use chlorine-based solvents such as brake parts cleaner or acetone—if you happen to splash some onto a painted surface, you will ruin the finish.



⚠️ WARNING
 NEVER clean with gasoline or other petroleum-based solvents. Most have low flash points, which make them extremely flammable. A risk of explosion and burning exists if these products are used. Serious personal injury may occur if this warning is ignored!



⚠️ CAUTION
 ALWAYS work in well-ventilated areas far from possible ignition sources when using solvents to clean machinery. Many solvents are toxic when inhaled or ingested. Use care when disposing of waste rags and towels to be sure they DO NOT create fire or environmental hazards.

SETUP

Bench Mounting

The strongest bench mounting option is a "Through Mount" where holes are drilled all the way through the workbench, and hex bolts, washers, and hex nuts are used to secure the machine to the workbench.

Another option for mounting is a "Direct Mount" where the machine is simply secured to the workbench with a lag screw.

NOTICE

This machine must be securely fastened to a stable working surface before operating. Failure to do so will produce unsafe operating conditions.

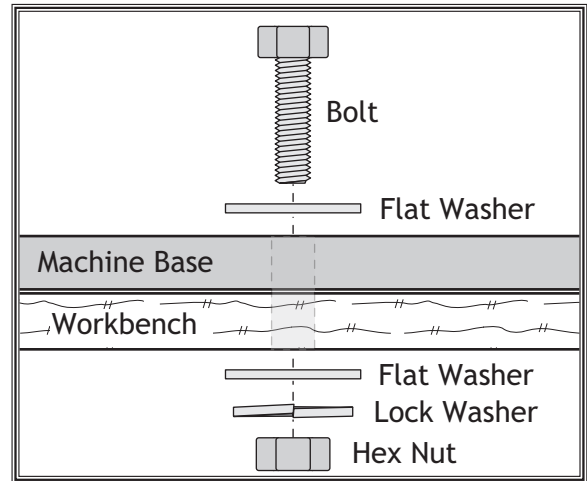

Figure 7. Example of a through mount.

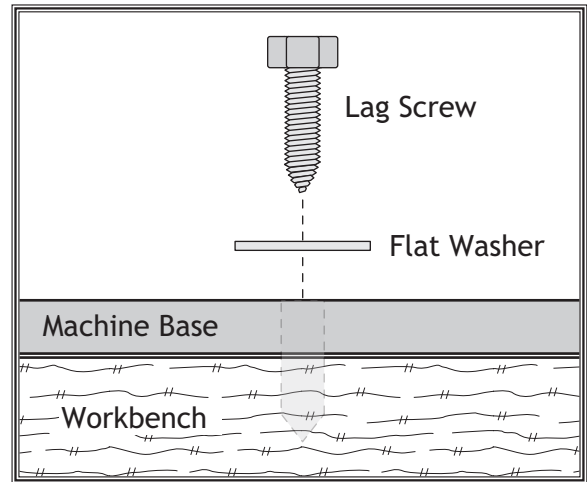

Figure 8. Example of a direct mount.

SETUP

Assembly

To assemble the jointer, do these steps:

1. DISCONNECT JOINTER FROM POWER!
2. Use two of the included M8-1.25 x 20 cap screws and lock washers 8mm to attach the fence support to the jointer bed, as shown in **Figure 9**.
3. Insert the locking plate assembly into the fence support, positioning it so the two pins are against the bottom edge of the fence support, as shown in **Figure 10**.
4. Secure the locking plate in position with the fence sliding handle, as shown in **Figure 11**.
5. Use the remaining four M8-1.25 x 20 cap screws and 8mm lock washers to attach the fence to the fence bracket assembly, as shown in **Figure 12**.

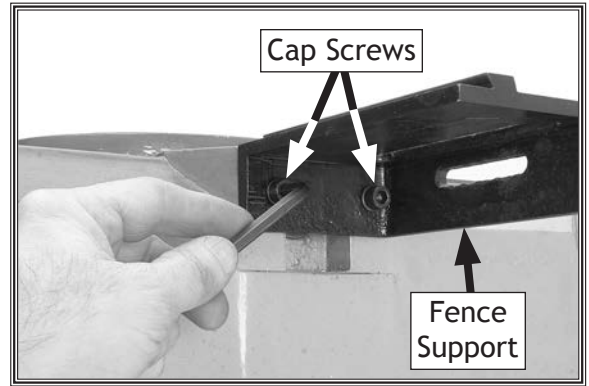

Figure 9. Attaching the fence support.

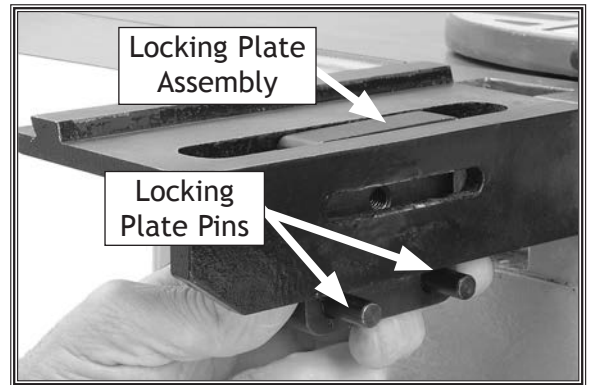

Figure 10. Inserting the locking plate.

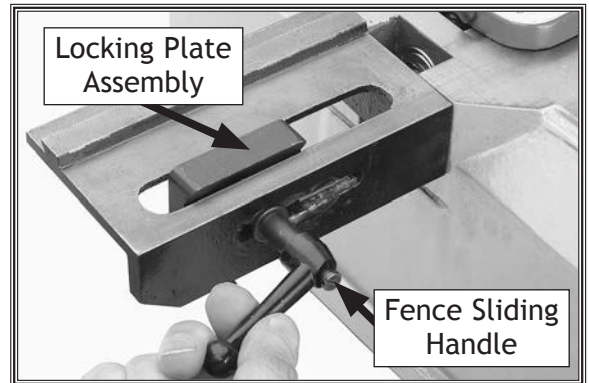

Figure 11. Installing fence sliding handle.

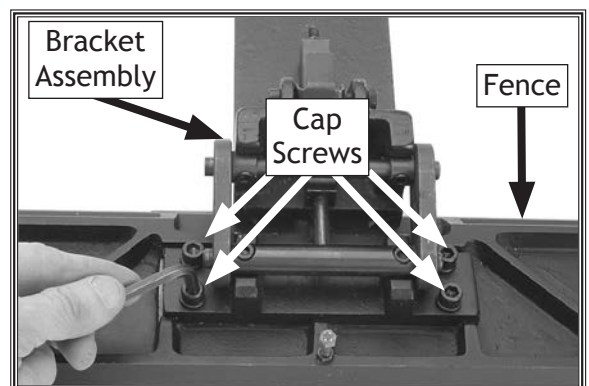

Figure 12. Attaching the fence bracket assembly to the fence.

SETUP

- Slide the fence bracket assembly over and onto the dovetail of the support and locking plate, as shown in Figure 13.

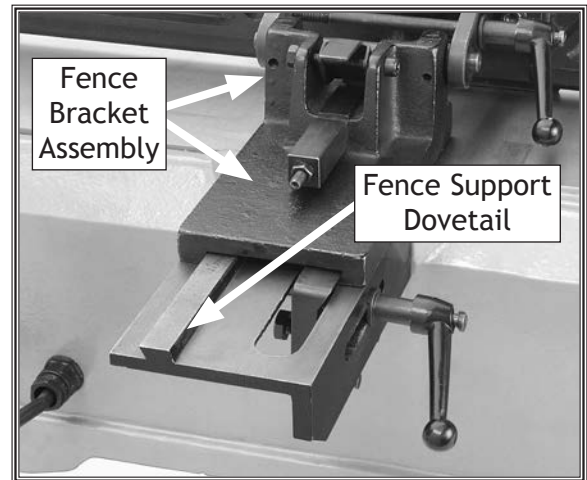

Figure 13. Sliding the fence bracket onto the fence support dovetails.

- Slide the fence forward until it contacts the cutterhead guard and the cutterhead guard completely covers the cutterhead, as shown in Figure 14.

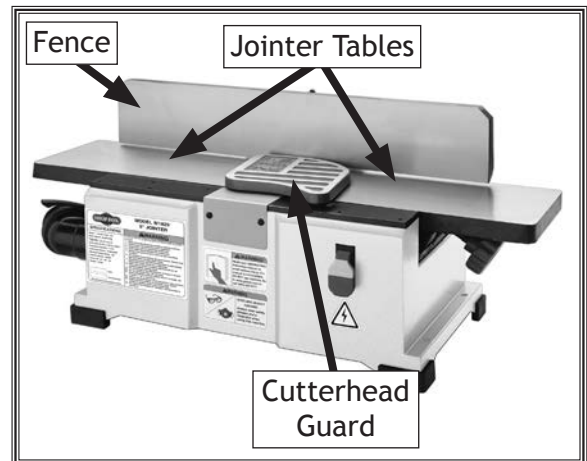

Figure 14. Fence positioned over the jointer tables.

- Install the fence tilting handle by screwing the handle shaft into the bracket assembly, as shown in Figure 15.

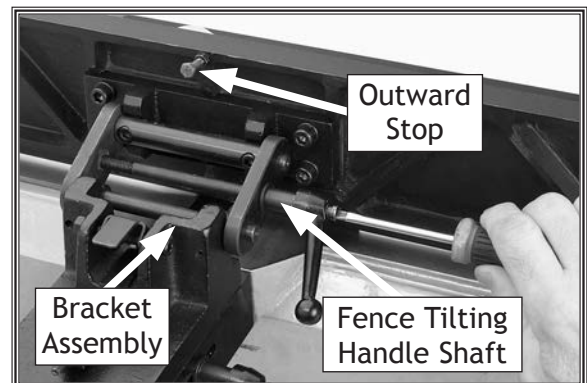

Figure 15. Installing the fence tilting handle.

SETUP

Dust Collection

The W1829 has a built-in dust collection fan and chip exhaust. It also includes a 2.5" dust port, clamp, and dust collection bag. The W1829 can also be hooked up to a pre-existing dust collection system.

Recommended CFM at Dust Port: 150 CFM

Do not confuse this CFM recommendation with the rating of the dust collector. To determine the CFM at the dust port, you must take into account many variables, including the CFM rating of the dust collector, the length of hose between the dust collector and the machine, the amount of branches or Y's, and the amount of other open lines throughout the system. Explaining this calculation is beyond the scope of this manual. If you are unsure of your system, consult an expert or purchase a good dust collection "how-to" book.

To install the dust port and collection bag, do these steps:

1. Install the dust port to the chip exhaust, as shown in **Figure 16**.
2. Slip the bag clamp over the collection bag, then attach the collection bag to the dust port and clamp it in place, as shown in **Figure 17**.

Recommended Adjustments

For your convenience, the adjustments listed below have been performed at the factory and no further setup is required to operate your machine.

However, because of the many variables involved with shipping, we recommend that you at least verify the following adjustments to ensure the best possible results from your new machine.

Step-by-step instructions for these adjustments can be found in **Service on Page 28**.

1. Knife settings (see **Page 30**).
2. Fence stop accuracy (see **Page 33**).

CAUTION

DO NOT operate this machine without an adequate dust collection system. This machine creates substantial amounts of wood dust while operating. Failure to use a dust collection system can result in short and long-term respiratory illness.



Figure 16. Installing the dust port.



Figure 17. Attaching the dust collection bag.

Power Connection

After you have completed all previous setup instructions and circuit requirements, the machine is ready to be connected to the power supply.

To avoid unexpected startups or property damage, use the following steps whenever connecting or disconnecting the machine.

Connecting Power

1. Turn the machine power switch **OFF**.
2. Insert the power cord plug into a matching power supply receptacle, as shown in **Figure 18**. The machine is now connected to the power source.

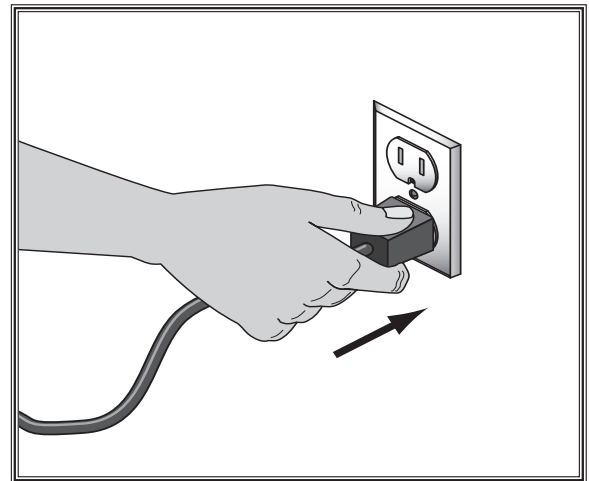

Figure 18. Connecting power

Disconnecting Power

1. Turn the machine power switch **OFF**.
2. Grasp the molded plug and pull it completely out of the power supply receptacle, as shown in **Figure 19**. **DO NOT** pull by the cord as this may damage the wires inside.

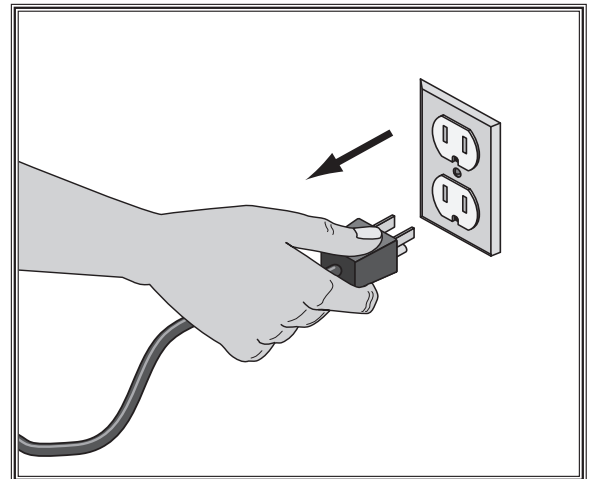

Figure 19. Disconnecting power.

Test Run

Once the assembly is complete, test run your machine to make sure it runs properly and is ready for regular operation.

The test run consists of verifying the following: 1) The motor powers up and runs correctly, and 2) the safety disabling mechanism on the switch works correctly.

If, during the test run, you cannot easily locate the source of an unusual noise or vibration, stop using the machine immediately, then review **Troubleshooting** on **Page 28**. If you still cannot remedy a problem, contact our Tech Support at (360) 734-3482 for assistance.

To test run the machine, do these steps:

1. Make sure you understand the safety instructions at the beginning of the manual, and verify that the machine is set up properly.
2. Ensure all tools and objects used during setup are cleared away from the machine.
3. Verify that the machine is operating correctly by turning it **ON**.
 - When operating correctly, the machine runs smoothly with little or no vibration or rubbing noises.
 - Investigate and correct strange or unusual noises or vibrations before operating the machine further. Always disconnect the machine from power when investigating or correcting potential problems.
4. Turn the machine **OFF**.
5. Remove the switch disabling key (see **Figure 20**).
6. Try to start the machine with the paddle switch.
 - If the machine *does not* start, the switch disabling feature is working as designed.
 - If the machine *does start*, immediately stop the machine. The switch disabling feature is not working correctly. Call Tech Support for help.

! WARNING

Projectiles thrown from the machine could cause serious eye injury. Wear safety glasses to reduce the risk of injury.

! WARNING

Loose hair and clothing could get caught in machinery and cause serious personal injury. Keep loose clothing rolled up and long hair tied up and away from machinery.

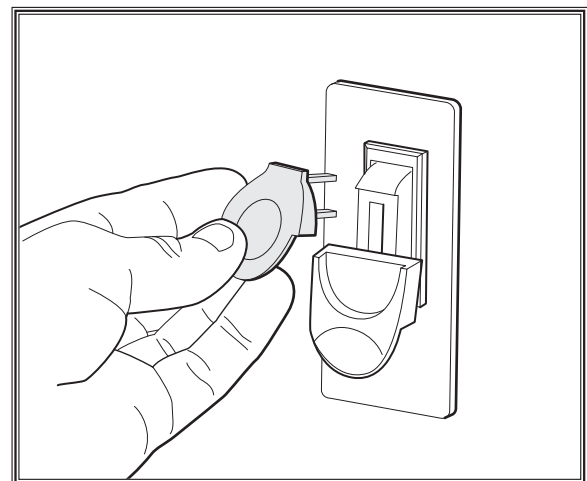

Figure 20. Removing switch key from paddle switch.

SETUP

OPERATIONS

General

This machine will perform many types of operations that are beyond the scope of this manual. Many of these operations can be dangerous or deadly if performed incorrectly.

The instructions in this section are written with the understanding that the operator has the necessary knowledge and skills to operate this machine. **If at any time you are experiencing difficulties performing any operation, stop using the machine!**

If you are an inexperienced operator, we strongly recommend that you read books or trade articles, or seek training from an experienced jointer operator before performing any unfamiliar operations. **Above all, your safety should come first!**

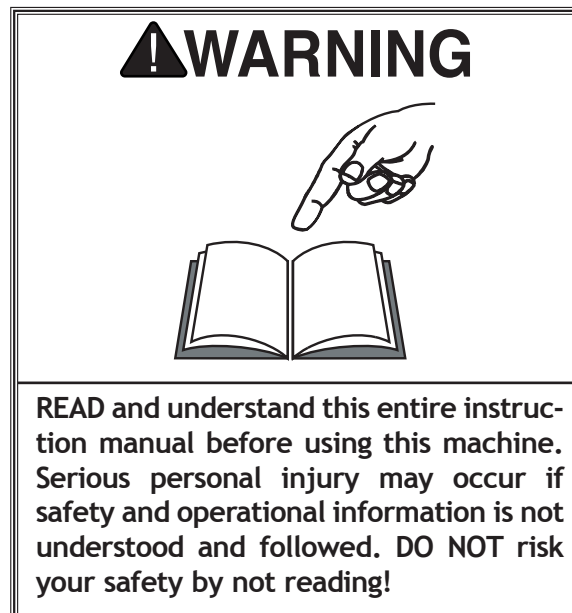

Basic Controls

This section covers the basic parts and controls used during routine operations. Refer to **Figures 21-22** for basic parts and control locations.

- A. ON/OFF Switch:** Starts and stops the cutterhead rotation.

The switch has a yellow safety key—removing it locks the switch in the OFF position. Always remove this yellow key when leaving the work area. This prevents unsupervised persons in your shop (especially children) from starting the jointer.

- B. Depth of Cut Adjustment Knob:** Changes the height of the infeed table to control the depth of cut.

- C. Fence Tilting Handle:** Locks the fence at the desired angle. Use fence stops to quickly set the fence to 90° (perpendicular to the tables), 45° inward, or 45° outward.

- D. Fence Sliding Handle:** Allows you to adjust the position of the fence over the tables. **ALWAYS** tighten it before you begin operations. The position of the fence determines the width of the cut as the workpiece moves over the cutterhead. **NEVER** operate the jointer if **ANY** part of cutterhead is exposed on the work area.

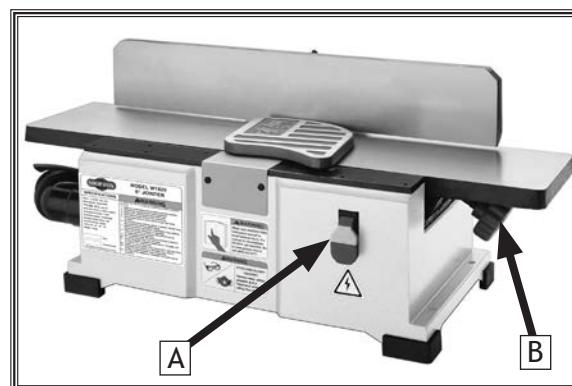

Figure 21. W1829 basic controls in front.

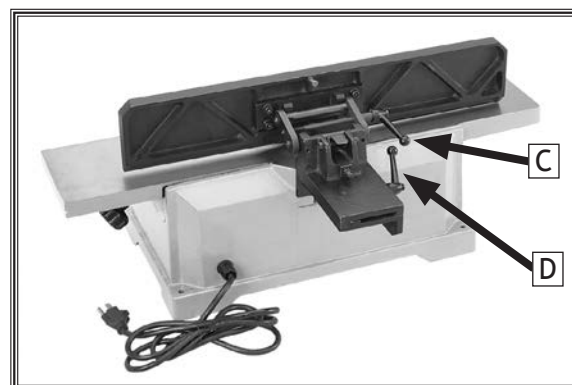

Figure 22. W1829 basic controls in back.

Stock Inspection & Requirements

Here are some rules to follow when choosing and jointing stock:

- **DO NOT joint or surface plane stock that contains loose knots.** Injury to the operator or damage to the workpiece can occur if the knots become dislodged during the cutting operation.
- **DO NOT joint or surface plane against the grain direction.** Cutting against the grain increases the likelihood of stock kickback, as well as tear-out on the workpiece.
- **Jointing and surface planing with the grain produces a better finish and is safer for the operator.** Cutting with the grain is described as feeding the stock on the jointer so the grain points down and toward you as viewed on the edge of the stock (see Figure 23).

Note: If the grain changes direction along the edge of the board, decrease the cutting depth and make additional passes.

- **Remove foreign objects from the stock.** Make sure that any stock you process with the jointer is clean and free of any dirt, nails, staples, tiny rocks or any other foreign objects that may damage the jointer blades.
- **Only process natural wood fiber through your jointer.** Never joint MDF, particle board, plywood, laminates or other synthetically made materials.
- **Make sure all stock is sufficiently dried before jointing.** Wood with a moisture content over 20% will cause unnecessary wear on the knives and poor cutting results.
- **DO NOT joint stock that is excessively warped or twisted.**
- **Make sure your workpiece exceeds the minimum dimension requirements (see Figures 24-25) before edge jointing or surface planing, or it may break or kick back during the operation!**

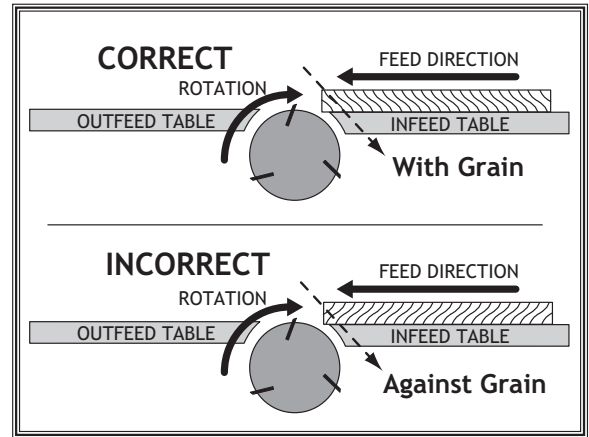

Figure 23. Correct setting for grain alignment.

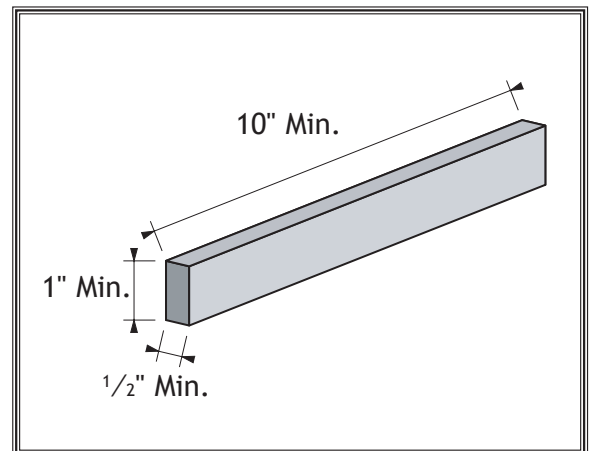

Figure 24. Minimum dimensions for edge jointing.

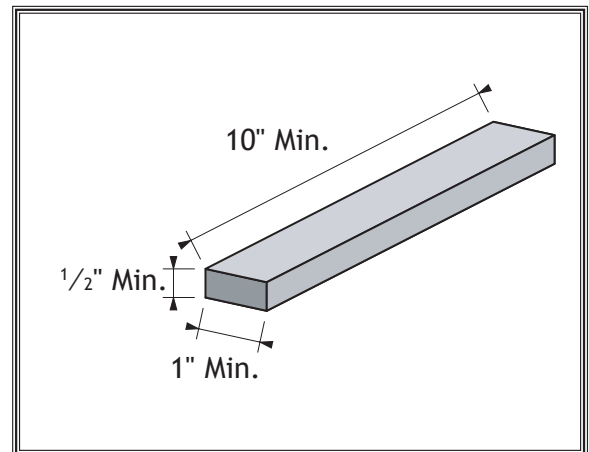

Figure 25. Minimum dimensions for surface planing.

Squaring Stock

Squaring stock involves four steps performed in the order below:

1. **Surface Plane on the Jointer:** The concave face of the workpiece is surface planed flat with the jointer (see **Figure 26**).
2. **Surface Plane on a Thickness Planer:** The opposite face of the workpiece is surface planed flat with a thickness planer (see **Figure 27**).
3. **Edge Joint on the Jointer:** The concave edge of the workpiece is jointed flat with the jointer (see **Figure 28**).
4. **Rip Cut on a Table Saw:** The jointed edge of the workpiece is placed against a table saw fence and the opposite edge cut off (see **Figure 29**).

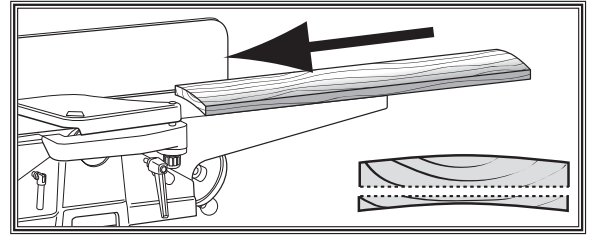

Figure 26. Surface plane on the jointer.

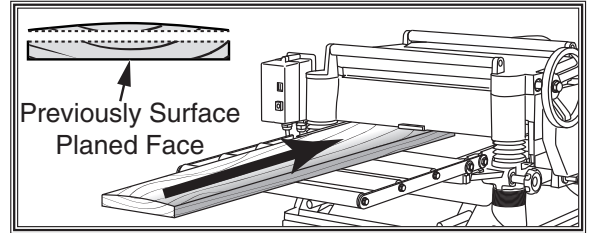

Figure 27. Surface plane on a thickness planer.

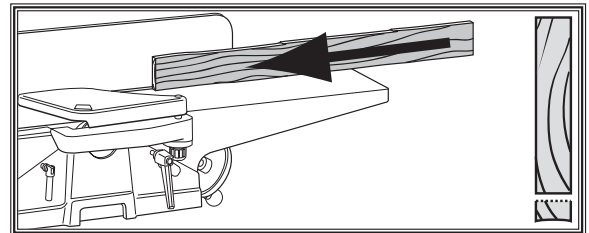

Figure 28. Edge joint on the jointer.

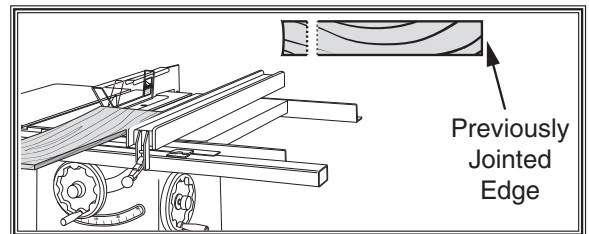

Figure 29. Rip cut on a table saw.

Surface Planing

The purpose of surface planing on the jointer is to make one flat face on a piece of stock (see **Figures 30-31**) to prepare it for surface planing on a thickness planer.

NOTICE

If you are not experienced with a jointer, set the depth of cut to 0", and practice feeding the workpiece across the tables as described below. This procedure will better prepare you for the actual operation.

To surface plane on the jointer, do these steps:

1. Read and understand **SAFETY**, beginning on **Page 6**.
2. Make sure your stock has been inspected for dangerous conditions as described in the **Stock Inspection & Requirements** instructions, on **Page 20**.
3. Set the cutting depth for your operation. (We suggest 1/32" for surface planing, using a more shallow depth for hard wood species or for wide stock.)
4. Make sure your fence is set to 90°.
5. If your workpiece is cupped (warped), place it so the concave side is face down on the surface of the infeed table.
6. Start the jointer.
7. With a push block in each hand, press the workpiece against the table and fence with firm pressure, and feed the workpiece over the cutterhead (**Figure 30**).

Note: When your leading hand (with push block) gets within 4" of the cutterhead, lift it up and over the cutterhead, and place the push block on the portion of the workpiece that is on the outfeed table. Now, focus your pressure on the outfeed end of the workpiece while feeding, and repeat the same action with your trailing hand when it gets within 4" of the cutterhead. To keep your hands safe, DO NOT let them get closer than 4" from the cutterhead when it is moving!

8. Repeat **Step 7** until the entire surface is flat.



Figure 30. Typical surface planing operation.

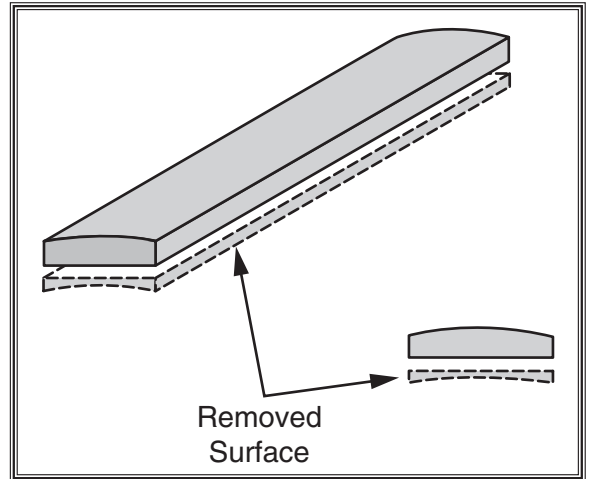

Figure 31. Illustration of surface planing results.

⚠️ WARNING

Failure to use push blocks when surface planing may result in cutterhead contact, which will cause serious personal injury. Always use push blocks to protect your hands when surface planing on the jointer.

Edge Jointing

The purpose of edge jointing is to produce a finished, flat-edged surface that is suitable for joinery or finishing (see **Figure 32**). It is also a necessary step when squaring rough or warped stock.

To edge joint on the jointer, do these steps:

1. Read and understand **SAFETY**, on **Page 6**.
2. Inspect your stock for dangerous conditions as described in the **Stock Inspection & Requirements** instructions, on **Page 20**.
3. Set the cutting depth for your operation.

Note: Between $1/16$ " and $1/8$ " for edge jointing, using a more shallow depth for certain species or for wide stock.

4. Make sure the fence is set to 90° .
5. If your workpiece is bowed (warped), place it so the concave side is face down on the surface of the infeed table.
6. Start the jointer.
7. Press the workpiece against the table and fence with firm pressure. Use your trailing hand to guide the workpiece through the cut, and feed the workpiece over the cutterhead (see **Figure 33**).

Note: If your leading hand gets within 4" of the cutterhead, lift it up and over the cutterhead, and place it on the portion of the workpiece that is over the outfeed table. Focus your pressure on the outfeed end of the workpiece while feeding, and repeat the same action with your trailing hand if it gets within 4" of the cutterhead. Keep your hands safe—**DO NOT** let them get closer than 4" from the cutterhead!

8. Repeat **Step 7** until the entire edge is flat.

NOTICE

If you are not experienced with a jointer, set the depth of cut to 0", and practice feeding the workpiece across the tables as described below. This procedure will better prepare you for the actual operation.

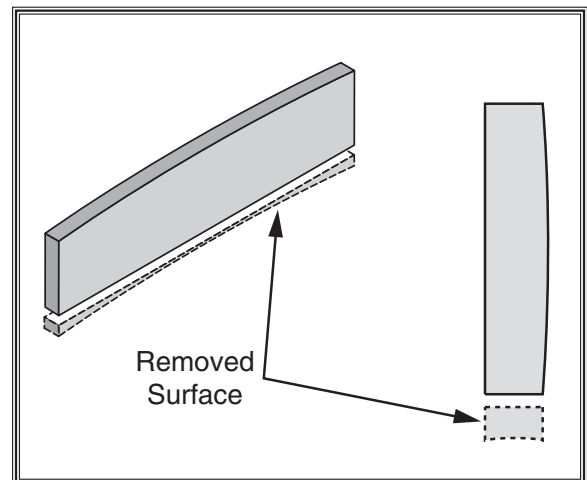

Figure 32. Illustration of edge jointing results.



Figure 33. Typical edge jointing operation.

Bevel Cutting

The purpose of bevel cutting is to cut a specific angle into the edge of a workpiece (see Figure 34).

The Model W1829 has preset fence stops at 45° inward, 90°, and 45° outward (135°). If your situation requires a different angle, the preset fence stops can be easily adjusted for your needs.

To bevel cut on the jointer, do these steps:

1. Read and understand **SAFETY**, beginning on **Page 6**.
2. Make sure your stock has been inspected for dangerous conditions as described in the **Stock Inspection & Requirements** instructions, on **Page 20**.
3. Set the cutting depth for your operation.

Note: We suggest between 1/16" and 1/8" for bevel cutting, using a more shallow depth for hard wood species or for wide stock.

4. Make sure your fence is set to the angle of your desired cut.
5. If your workpiece is cupped (warped), place it so the concave side toward the fence.
6. Start the jointer.
7. With a push block in your leading hand, press the workpiece against the table and fence with firm pressure, and feed the workpiece over the cutterhead, as in **Figure 35**.

Note: If your leading hand gets within 4" of the cutterhead, lift it up and over the cutterhead, and place the push block on the portion of the workpiece that is on the outfeed table. Now, focus your pressure on the outfeed end of the workpiece while feeding, and repeat the same action with your trailing hand when it gets within 4" of the cutterhead. To keep your hands safe, DO NOT let them get closer than 4" from the cutterhead when it is moving!

8. Repeat **Step 7** until the angled cut is satisfactory to your needs.

NOTICE

If you are not experienced with a jointer, set the depth of cut to 0", and practice feeding the workpiece across the tables as described below. This procedure will better prepare you for the actual operation.

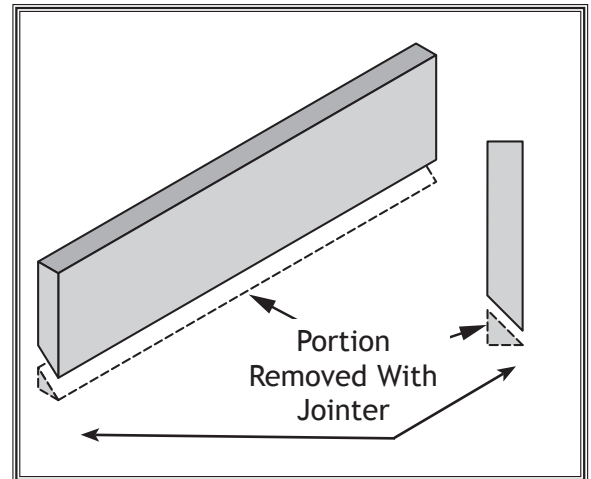

Figure 34. Illustration of bevel cutting results.

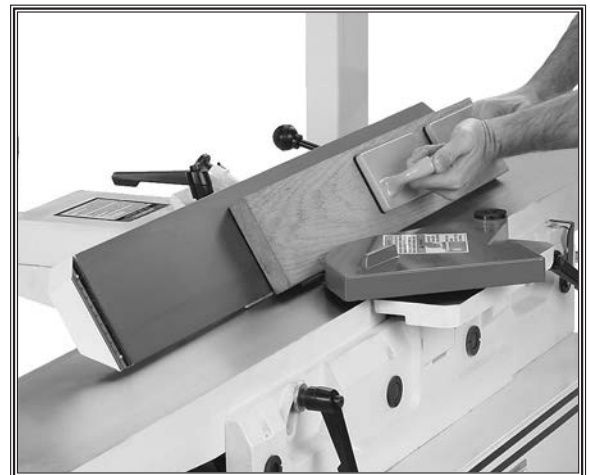

Figure 35. Typical bevel cutting operation.

ACCESSORIES

The following jointer accessories may be available through your local Woodstock International Inc. Dealer. If you do not have a dealer in your area, these products are also available through online dealers. Please call or e-mail Woodstock International Inc. Customer Service to get a current listing of dealers at: 1-800-840-8420 or at sales@woodstockint.com.

D3319—6" Replacement Jointer Knives (Set of 2)

D1123—Steelex® Knife Sharpener

Add a razor hone to your planer and jointer knives with this hand-held sharpening device. This handy tool sharpens flat and beveled surfaces quickly and easily. Great for touch-ups.

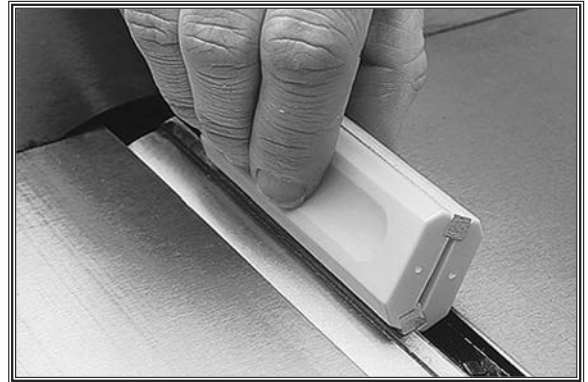

D3640—Shop Fox Tool Table Plus

This new tool table plus was designed to answer customer requests for a slightly wider and taller table. It is built to accommodate a variety of bench-top machines including the W1829 Jointer.



W1218A—Rotacator®

Adjust the W1829 to within $\pm .001$ ". The magnetic base keeps the Rotacator® firmly in position while the indicator indexes at 0°, 90°, 180°, and 270° for unmatched versatility. This is an extremely precise and useful tool!



OPERATIONS

D2675—Safety Glasses

D2676—Adjustable Safety Glasses

Exceeding ANSI Z87.1-1989 standards for impact resistance, these Safety Glasses offer outstanding eye protection. Wrap around side shields provide additional protection and a wide field of view. Model D2676 features easily adjustable ear pieces.

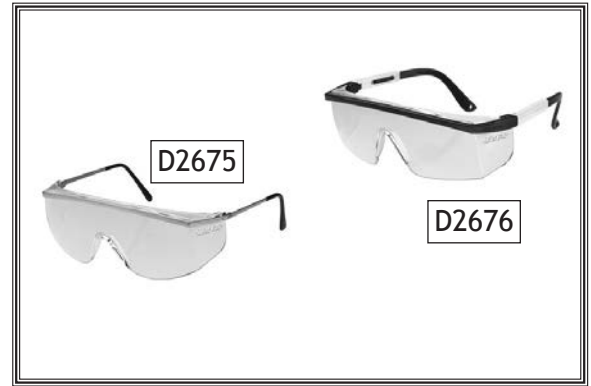

D2759—Safety Filter Mask

This Safety Filter Mask provides greater protection over paper filters with its form fitting cloth seal. Level 2 filtration provides 98.6% filtration. Ideal for the dusty shop and work environments. One size fits all.

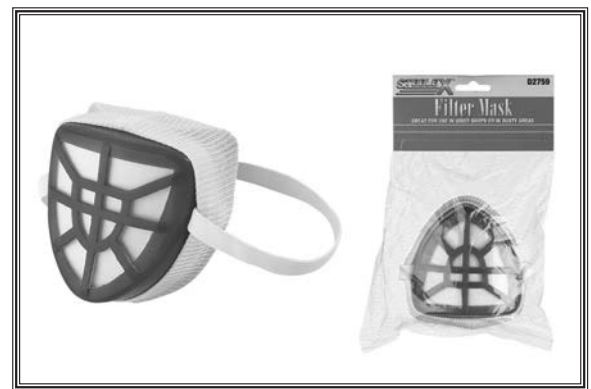

W1041—3" x 2 1/2" Adapters

W1044—4" x 2 1/2" Adapters

These adapters will allow you to connect the 2 1/2" dust chute of the W1829 to an existing dust collection system with standard 3" or 4" fittings.



MAINTENANCE

General

Regular periodic maintenance on your machine will ensure its optimum performance. Make a habit of inspecting your machine each time you use it.

Check for the following conditions and repair or replace when necessary:

- Loose mounting bolts.
- Worn switch.
- Worn or damaged cords and plugs.
- Damaged V-belt.
- Any other condition that could hamper the safe operation of this machine.

Cleaning

Frequently blow-off sawdust and chips with compressed air. This is especially important for the internal working parts and motor. Dust build-up around the motor is a sure way to decrease its life span.

Table & Base

Tables can be kept rust-free with regular applications of products like SLIPIT®. For long term storage you may want to consider products like Boeshield T-9™.

V-Belts

To ensure optimum power transmission from the motor to the blade, the V-belt must be in good condition (free from cracks, fraying and wear) and properly aligned and tensioned (refer to **V-Belt Replacement** on **Page 36**).

⚠ WARNING

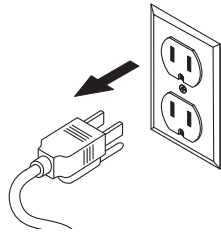

MAKE SURE that your machine is unplugged during all maintenance procedures! If this warning is ignored, serious personal injury may occur.

Lubrication

Since all bearings are sealed and permanently lubricated, simply leave them alone until they need to be replaced. Do not lubricate them.

SERVICE

General

This section covers the most common service adjustments or procedures that may need to be made during the life of your machine. If you require additional machine service not included in this section, please contact Woodstock International Technical Support at (360) 734-3482 or send e-mail to: tech-support@shopfox.biz.

Troubleshooting

This section covers the most common problems and corrections with this type of machine. **WARNING! DO NOT** make any adjustments until power is disconnected and moving parts have come to a complete stop!

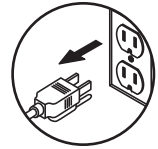

Motor & Electrical

PROBLEM	POSSIBLE CAUSE	CORRECTIVE ACTION
Machine does not start or a breaker trips.	<ol style="list-style-type: none"> 1. Safety key removed from ON/OFF switch. 2. Plug/receptacle is at fault or wired incorrectly. 3. Power supply is at fault/switched OFF. 4. Lockout key is malfunctioning. 5. Motor brushes are at fault. 6. Motor ON/OFF switch is at fault. 7. Wiring is open/has high resistance. 8. Motor is at fault. 	<ol style="list-style-type: none"> 1. Replace safety key. 2. Test for good contacts; correct the wiring. 3. Ensure hot lines have correct voltage on all legs and main power supply is switched ON. 4. Replace lockout key; replace switch. 5. Remove/replace brushes. 6. Replace faulty ON/OFF switch. 7. Check for broken wires or disconnected/corroded connections, and repair/replace as necessary. 8. Test/repair/replace.
Machine stalls, is underpowered, or is overloaded.	<ol style="list-style-type: none"> 1. Wrong workpiece material (wood). 2. Cutterhead belt slipping. 3. Plug/receptacle is at fault. 4. Motor brushes are at fault. 5. Motor bearings are at fault. 6. Knives dull, feed rate is too fast depth of cut too great. 7. Motor has overheated. 8. Motor is at fault. 	<ol style="list-style-type: none"> 1. Use wood with correct moisture content, without glues, and little pitch/resins. 2. Replace cutterhead belt and re-tension. 3. Test for good contacts; correct the wiring. 4. Remove/replace brushes. 5. Test by rotating shaft; rotational grinding/loose shaft requires bearing replacement. 6. Use sharp knives; reduce feed rate/depth of cut. 7. Clean off motor, let cool, and reduce workload. 8. Test/repair/replace.

Motor & Electrical (continued)

PROBLEM	POSSIBLE CAUSE	CORRECTIVE ACTION
Machine has vibration or noisy operation.	<ol style="list-style-type: none"> 1. Motor or component is loose. 2. Knife blades, clamp or jack screws are at fault. 3. Belts worn or loose. 4. Motor fan is rubbing on fan cover. 5. Loose mounting bolts. 6. Blade is at fault. 	<ol style="list-style-type: none"> 1. Inspect/replace stripped or damaged bolts/nuts, and re-tighten with thread locking fluid. 2. Resharpener/replace knives as required; set knife alignment correctly. 3. Inspect/replace belts with a new ones. 4. Replace dented fan cover; replace loose/damaged fan. 5. Replace/tighten as required. 6. Replace warped, bent, or twisted blade; resharpen dull blade.

Operation

PROBLEM	POSSIBLE CAUSE	CORRECTIVE ACTION
Excessive snipe (gouge in the end of the board that is uneven with the rest of the cut).	<ol style="list-style-type: none"> 1. Knives set too high. 2. Operator pushing down on trailing end of the workpiece. 	<ol style="list-style-type: none"> 1. Set the knives just even with the outfeed table when they're at TDC (top dead center). 2. Reduce/eliminate downward pressure on that end of workpiece.
Workpiece stops in the middle of the cut.	<ol style="list-style-type: none"> 1. Knives set too low. 	<ol style="list-style-type: none"> 1. Set the knives just even with the outfeed table when they're at TDC (top dead center).
Chipping.	<ol style="list-style-type: none"> 1. Knots or conflicting grain direction in wood. 2. Nicked or chipped blades. 3. Feeding workpiece too fast. 4. Taking too deep of a cut. 	<ol style="list-style-type: none"> 1. Inspect workpiece for knots and grain (Page 20); only use clean stock. 2. Adjust one of the nicked knives sideways; replace knives (Page 32). 3. Slow down the feed rate. 4. Take a smaller depth of cut. (Always reduce cutting depth when surface planing or working with hard woods.)
Fuzzy Grain.	<ol style="list-style-type: none"> 1. Wood may have high moisture content or surface wetness. 2. Dull knives. 	<ol style="list-style-type: none"> 1. Check moisture content and allow to dry if moisture is over 15%. 2. Replace knives (Page 32).
Long lines or ridges that run along the length of the board.	<ol style="list-style-type: none"> 1. Nicked or chipped knives. 	<ol style="list-style-type: none"> 1. Sharpen or replace knives (Page 32).
Uneven cutter marks, wavy surface, or chatter marks across the face of the board.	<ol style="list-style-type: none"> 1. Feeding workpiece too fast. 2. Knives not adjusted at even heights in the cutterhead. 	<ol style="list-style-type: none"> 1. Slow down the feed rate. 2. Adjust the knives so they are set up evenly in the cutterhead (Page 30).
Board edge is concave or convex after jointing.	<ol style="list-style-type: none"> 1. Board not held with even pressure on infeed and outfeed table during cut. 2. Board started too uneven. 3. Board has excessive bow or twist along its length. 4. Insufficient number of passes. 	<ol style="list-style-type: none"> 1. Hold board with even pressure as it moves over the cutterhead. 2. Take partial cuts to remove the extreme high spots before doing a full pass. 3. Surface plane one face so there is a good surface to position against the fence. 4. It may take 3 to 5 passes to achieve a perfect edge, depending on the starting condition of the board and the depth of cut.

Checking/Adjusting Knife Height

The knives **MUST** be level with the outfeed table when they are at top dead center (their highest point during rotation) or the workpiece cannot be safely fed across the jointer.

Tools Needed	Qty
Hex Wrench 4mm	1
Hex Wrench 5mm	1

Checking Knife Height

1. DISCONNECT JOINTER FROM POWER SOURCE!
2. Place a straightedge on the outfeed table so it extends over the cutterhead. For best results, use a straightedge that will stand on edge without having to be held in place, as illustrated in **Figure 36**.
3. Rotate the cutterhead under the straightedge.
 - If the knives are parallel to the straightedge, rotating the cutterhead will move the straightedge slightly ($1/8$ ") forward; no adjustments are necessary.
 - If the knives fall below the straightedge, or if the knives lift the straightedge and move it more than $1/8$ " when you rotate the cutterhead, the knives must be adjusted.

Adjusting Knife height

1. DISCONNECT JOINTER FROM POWER SOURCE!
2. Block the cutterhead guard back so the cutterhead is fully exposed.
3. Locate the knife clamp screws and knife adjustment jack screws (see **Figures 37-38**).

Note: You will perform the procedure in Steps 4-8 for each of the two knives.

4. Use a 4mm hex wrench to loosen the four knife clamp screws.
5. Adjust the two jack screws until both ends are slightly below the straightedge.

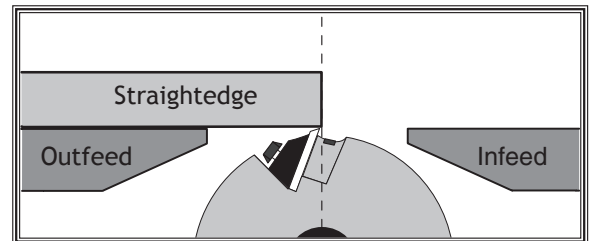
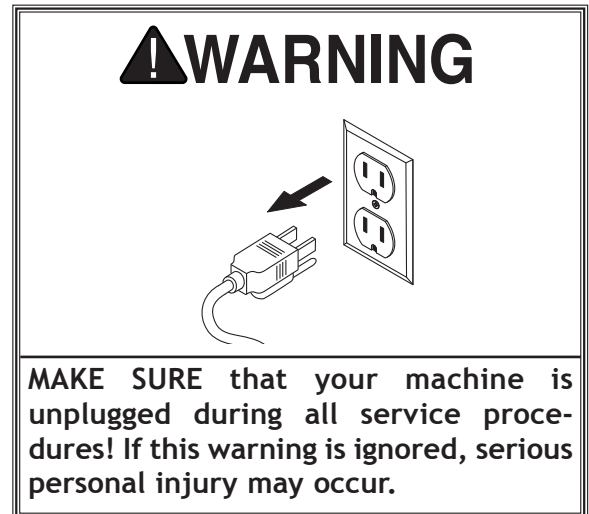

Figure 36. Illustration of a typical cutterhead alignment setup.

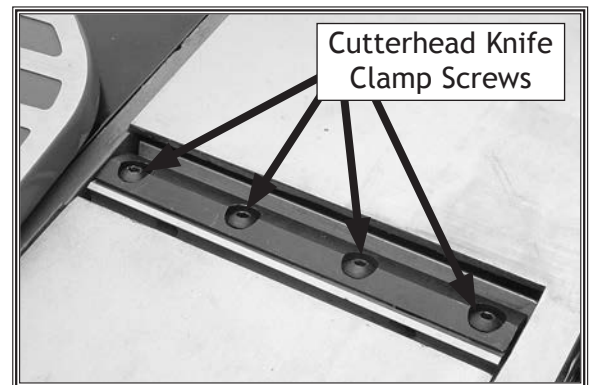

Figure 37. Cutterhead knife clamp screws.

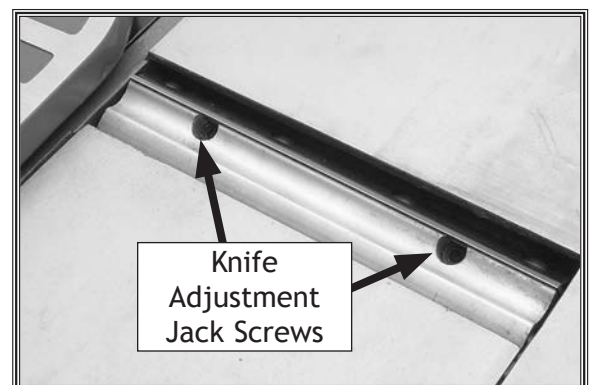

Figure 38. Knife adjustment jack screws.

SERVICE

6. Move the straightedge to position **A**, as shown in **Figure 39**. Turn the jack screw nearest the fence counterclockwise until the end of the knife touches the straightedge.
7. Move the straightedge to position **B**, as shown in **Figure 39**. Turn the jack screw nearest the guard counterclockwise until the end of the knife touches the straightedge.
8. Slightly tighten the clamp screws, according to the proper tightening sequence, as shown in **Figure 40**. Repeat **Steps 6-7** for the other cutterhead knife.

Note: Slightly tightening the clamp screws maintains the knife position while performing the same step on the other knife. They will be final tightened in a later step.

8. Without disturbing the knife clamp, rotate the cutterhead slightly to check the knife height.
 - If the knife moves the straightedge slightly ($\frac{1}{8}$ " forward and back on the table, the knife height is set correctly.
 - If the knife does not move the straightedge slightly ($\frac{1}{8}$ " forward and back on the table, continue to make fine adjustments with the jack screws until the knife is set correctly.
10. When the knife heights are set correctly, final tighten each of the knives' clamp screws according to the proper tightening sequence (see **Figure 40**).
11. Return the cutterhead guard to the operating position and ensure it is working properly.
12. Re-align the fence and tables as needed.
13. Perform a test cut on suitable piece of scrap material.

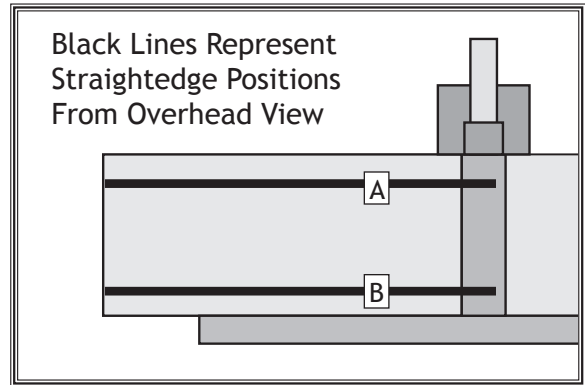

Figure 39. Straightedge positions A and B.

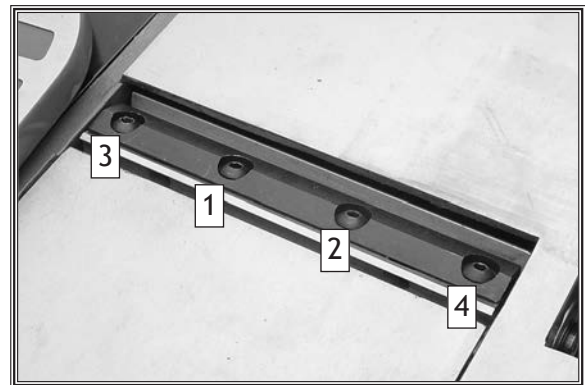

Figure 40. Knife clamp screw tightening sequence.

Replacing Knives

Sharp cutterhead knives provide the best cutting results. Under normal operation these knives will become dull and need to be sharpened or replaced. Refer to **Troubleshooting** (see **Page 28**) to determine if the knives may be dull.

Tools Needed	Qty
Hex Wrench 4mm	1
Hex Wrench 5mm	1

To replace the cutterhead knives, do these steps:

1. DISCONNECT JOINTER FROM POWER.
2. Carefully rotate the cutterhead until the clamp screws are accessible.
3. Remove the cutterhead clamp screws fastening the knife to the cutterhead (see **Figure 41**). Carefully remove the knife and clamp from the cutterhead.
4. Repeat **Steps 2-3** for the second cutterhead knife.
5. Clean the cutterhead thoroughly before installing new knives or re-installing sharpened knives.
6. Install one knife, clamp it in the cutterhead, and slightly tighten each of the clamp screws in sequence, as shown in **Figure 42**.

Note: By tightening the clamp screws out of sequence, jointing results may be hampered. Following the tightening sequence reduces that possibility.

7. Repeat **Step 6** for the second cutterhead knife.
8. Check the alignment of the knives to the outfeed table. They should be parallel to the outfeed table.
 - If the knife is not parallel to the outfeed table, adjust the jack screws to fine tune the knife height. Refer to **Checking/Adjusting Knife Height** on **Page 30**.
9. Follow the tightening sequence and final tighten each of the clamp screws for both knives, as shown in **Figure 42**.
10. Ensure cutterhead guard is working properly. Align the fence as needed. Perform a test cut on a suitable piece of scrap material.

! WARNING

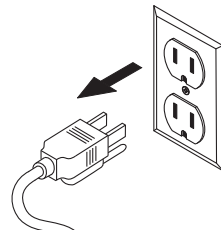

MAKE SURE that your machine is unplugged during all service procedures! If this warning is ignored, serious personal injury may occur.

! CAUTION

Cutterhead knives are sharp and laceration injuries may occur. Use caution when handling the cutterhead knives.

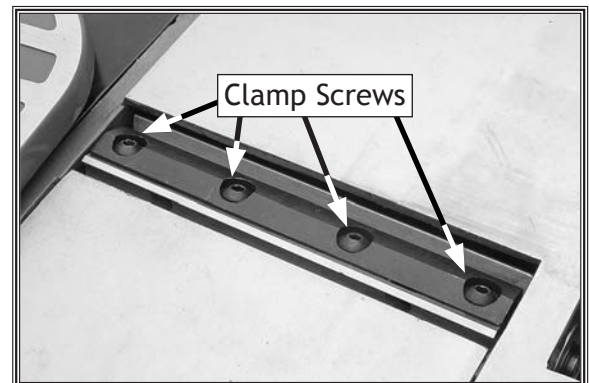

Figure 41. Cutterhead clamp screw location.

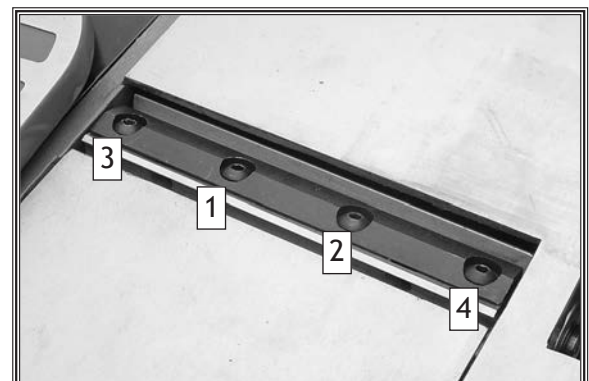

Figure 42. Knife clamp screw tightening sequence.

Setting Fence Angle Stops

This section provides instructions for setting the fence angle stops precisely at 90°, 45° inward, or 45° outward.

Note: To ensure accurate results when edge jointing, check the accuracy of these settings frequently (monthly at a minimum) and re-adjust them if necessary.

Tools Needed	Qty
Flathead Screwdriver	1
Wrench 8mm.....	1
Wrench 10mm	1

Setting 90° Fence Angle Stop

1. DISCONNECT THE JOINTER FROM POWER!
 2. Position the fence over the bed and tighten the sliding handle, loosen the fence tilting handle.
 3. Press the forward tab of the limit plate into the rear slot of the limit block.
 4. Tilt the fence as far as it will go towards 90° (perpendicular to the table) until it hits the limit block shaft. Tighten the fence tilting handle.
 5. Use a square to check the angle of the fence, as shown in **Figure 44**.
 - If the fence is perpendicular to the table, the 90° stop is set correctly; no additional steps are necessary. Proceed to set the 45° inward and 45° outward stops (see **Page 34**).
 - If the fence is not perpendicular to the table, adjust the 90° stop by doing **Steps 6-9**.
 6. Loosen the fence tilting handle, bring the fence to 90° with the square set against the fence, then tighten the handle.
- Note:** Keep the limit plate tab in the rear slot of the limit block.
7. Loosen the jam nut (located at the rear of the limit block shaft).
 8. Using a flathead screwdriver, turn the limit block shaft until it hits the fence.
 9. Tighten the jam nut. The 90° stop is now set.

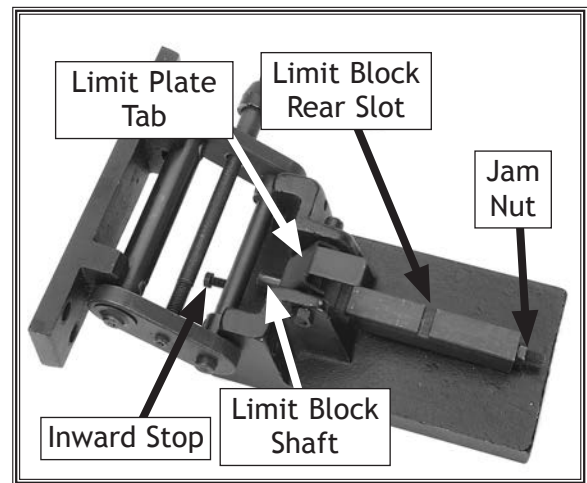
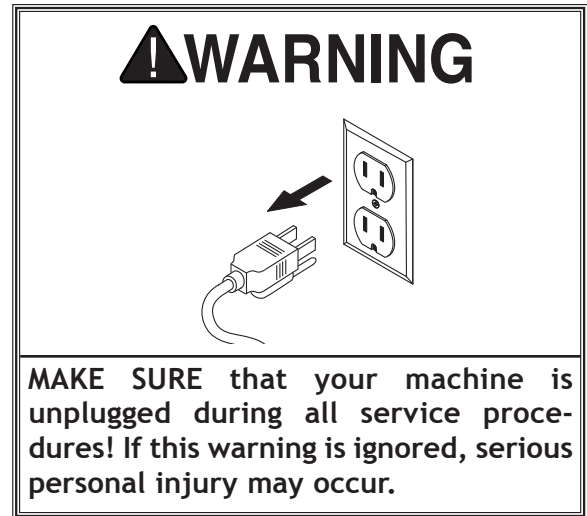

Figure 43. Fence stop parts identification.



Figure 44. Checking the 90° stop.

SERVICE

Setting 45° Inward Stop

1. DISCONNECT JOINTER FROM POWER!
2. With the fence positioned over the bed and the sliding handle locked, loosen the fence tilting handle and release the limit tab.
3. Tilt the fence towards the table as far as it will go, then tighten the fence tilting handle.

Note: When you tilt the fence towards the table, it will stop when it hits the inward stop bolt.

4. Use a combination square to check the angle of the fence, as shown in **Figure 45**.
 - If the fence leans 45° towards the table, the inward 45° stop is set correctly; proceed to set the outward 45° stop (see **Page 35**).
 - If the fence does not lean 45° towards the table, adjust the inward 45° stop by performing **Steps 5-9**.
5. Loosen the fence tilting handle, bring the fence to 45°, then tighten the handle just enough to keep the fence in position.
6. Remove the limit block from the fence bracket assembly and set it aside.
7. Using two 8mm wrenches, adjust the inward stop bolt (see **Figure 46**) until it contacts the fence at precisely 45° inward, then tighten the jam nut (where the bolt meets the bracket assembly) while holding the stop bolt in place. Some trial-and-error will be required to set this stop correctly.
8. Use two 8mm wrenches to tighten the hex nut on the inward stop as you hold the stop in place.
9. Put the limit block back, bring the fence back to 90° and tighten the tilting handle.

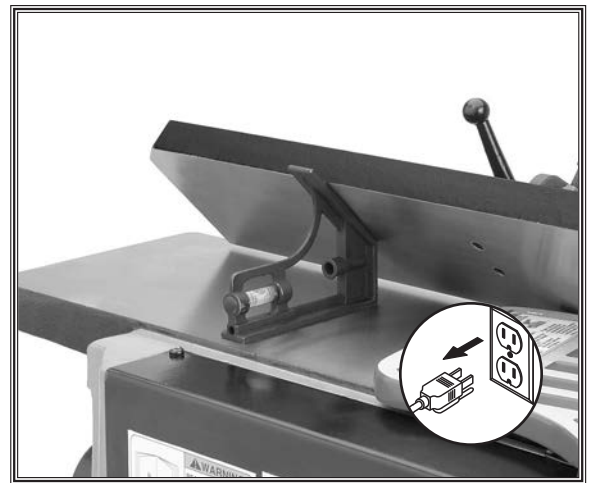

Figure 45. Checking the inward 45° stop.

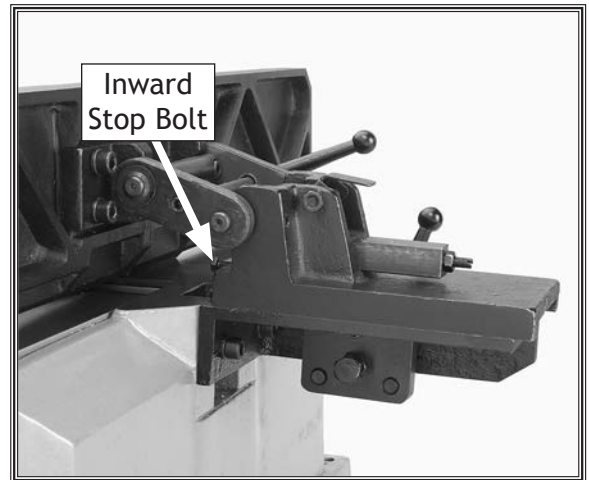

Figure 46. Adjusting the inward stop bolt.

Setting 45° Outward Stop

1. DISCONNECT JOINTER FROM POWER!
2. Loosen the fence tilting handle, remove the limit block and set it aside.
3. Tilt the fence backward (away from the table) until it stops.

Note: The fence will stop when the outward stop bolt hits the fence bracket.

4. Use a square to check the angle of the fence, as shown in **Figure 47**.
 - If the fence is tilting away from the table at 45°, the outward stop is set correctly. Put the limit block back, bring the fence to 90°, and tighten the tilting handle.
 - If the fence is not tilting away from the table at 45°, perform **Steps 5-6** to set the outward stop correctly.



Figure 47. Checking the outward 45° stop.

5. With the outward stop bolt resting against the fence bracket, use an 8mm wrench to adjust the length of the stop until the fence is at 45°, then tighten the jam nut (see **Figure 48**).
6. Put the limit block back, bring the fence to 90° and tighten the fence tilting handle.

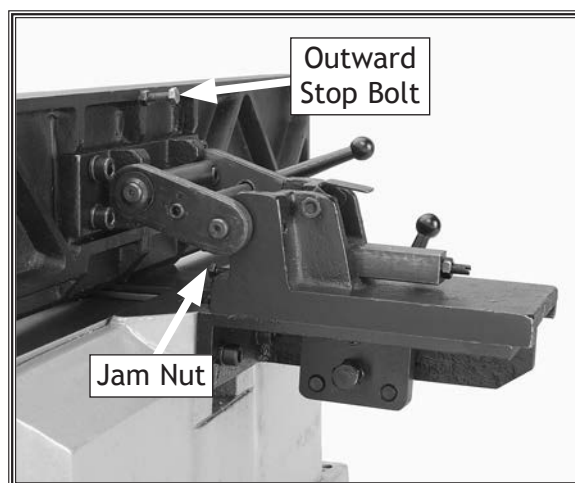

Figure 48. Outward stop bolt detail.

V-Belt Replacement

The Model W1829 uses two belts to drive the cutterhead and the dust collection impeller. When these belts are not tensioned correctly, misaligned, or damaged, your jointer will not function properly.

The part number for the replacement drive belt is X1829070; the part number for the replacement fan belt is X1829092.

Refer to the parts diagram in this manual when fixing belt problems. If you need further assistance, call our Tech Support at (360) 734-3482 or send e-mail to: tech-support@shopfox.biz.

To realign or replace the cutterhead belt, do these steps:

1. DISCONNECT JOINTER FROM POWER!
2. While facing the rear of the jointer, tip it away from you until it rests on the fence assembly.
3. Remove the screws that hold the motor cover to the jointer base. Lift the cover off and set it aside.
4. Inspect the cutterhead belt for proper tension, straight alignment, and possible damage or wear.

Note: The belt is properly tensioned if it deflects about $\frac{3}{8}$ " when you press down on middle of the belt with moderate pressure from your thumb or forefinger. The belt is properly aligned if it lies flat and straight on the motor shaft and drive pulley. Belt damage will be evident upon inspection.

5. Loosen the four motor mounting cap screws (see **Figure 49**), but do not remove them.
6. Replace a damaged belt with a new one. Realign and re-tension the belt.
7. Tighten the motor mounting screws and replace the motor cover.
8. Test run the jointer, as described on **Page 18**. If this procedure does not solve the problem, call Tech Support.

Note: The fan belt is installed without releasing motor tension. Simply slide the old belt off. Slide the new belt on and replace the motor cover.

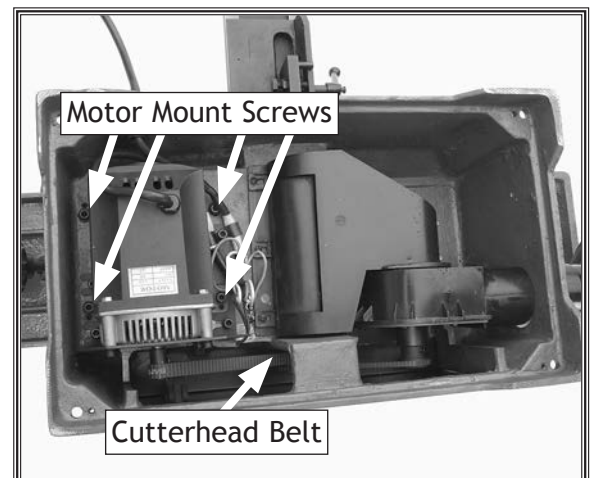

Figure 49. Motor mounting screws and belt locations.

Motor Brush Replacement

This jointer has a universal motor that uses carbon brushes, which are considered wear-items. Refer to the troubleshooting guide to determine if the motor brushes must be replaced.

You can order a new brush kit (two brush assemblies) by calling customer service and ordering part X1829024-1.

To replace motor brushes, do these steps:

1. DISCONNECT JOINTER FROM POWER!
2. While facing the rear of the jointer, tip it away from you until it rests on the fence assembly.
3. Remove the screws that hold the motor cover to the jointer base. Lift the cover off and set it aside.
4. Vacuum all dust and debris from the motor and belt areas.
5. Use a dime to unscrew the brush caps. (See **Figure 50** to locate the brush caps.)

Note: When you remove the brush caps, a spring will pop out of the socket; the carbon brush is firmly attached to this spring. When you buy a new brush kit, you will get a pair of brush/spring assemblies.

6. Check the brushes for wear. If a brush is worn to less than $\frac{3}{32}$ " in length, replace both brushes.
7. Insert the brush assemblies, positioning them so they slide into the slots built into the sockets, then press the brush cap against the spring, push it into the socket, and turn it to lock it in the motor housing.
8. Replace the motor cover.
9. Test run the jointer, as described on **Page 18**.
 - If the jointer runs properly, you are done.
 - If the motor does not start, either the brushes are not correctly aligned in the sockets or there is another problem with the motor or wiring. Refer to the **Troubleshooting** section for assistance.

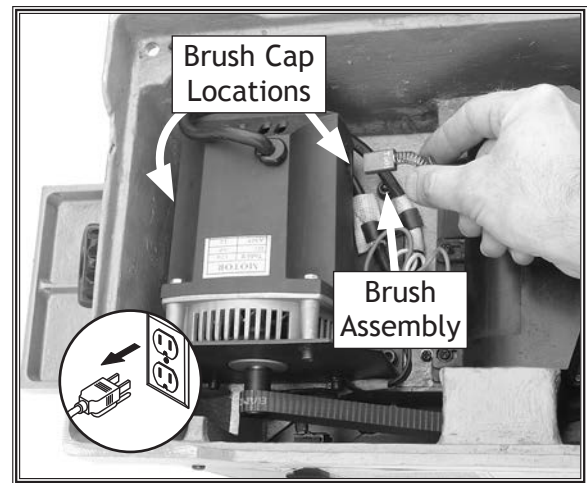

Figure 50. Removing a motor brush.

Electrical Safety Instructions

These pages are current at the time of printing. However, in the spirit of improvement, we may make changes to the electrical systems of future machines. Study this diagram carefully. If you notice differences between your machine and these wiring diagrams, call Woodstock International Technical Support at (360) 734-3482.

WARNING

SHOCK HAZARD. Working on wiring that is connected to a power source is extremely dangerous. Touching electrified parts will result in personal injury including but not limited to severe burns, electrocution, or death. Disconnect the power from the machine before servicing electrical components!

QUALIFIED ELECTRICIAN. Due to the inherent hazards of electricity, only a qualified electrician should perform wiring tasks on this machine. If you are not a qualified electrician, get help from one before attempting any kind of wiring job.

WIRE CONNECTIONS. All connections must be tight to prevent wires from loosening during machine operation. Double-check all wires disconnected or connected during any wiring task to ensure tight connections.

WIRE/COMPONENT DAMAGE. Damaged wires or components increase the risk of serious personal injury, fire, or machine damage. If you notice that any wires or components are damaged while performing a wiring task, replace those wires or components before completing the task.

MOTOR WIRING. The motor wiring shown in these diagrams is current at the time of printing, but it may not match your machine. Always use the wiring diagram inside the motor junction box.

MODIFICATIONS. Using aftermarket parts or modifying the wiring beyond what is shown in the diagram may lead to unpredictable results, including serious injury or fire.

CAPACITORS/INVERTERS. Some capacitors and power inverters store an electrical charge for up to five minutes after being disconnected from the power source. To avoid being shocked, wait at least this long before working on these components.

ELECTRICAL REQUIREMENTS. You **MUST** follow the electrical requirements at the beginning of this manual when connecting your machine to a power source.

EXPERIENCING DIFFICULTIES. If you are experiencing difficulties understanding the information included in this section, contact our Technical Support at (360) 734-3482.

NOTICE	WIRING DIAGRAM COLOR KEY				
The photos and diagrams included in this section are best viewed in color. You can view these pages in color at www.shopfox.biz .	BLACK	BLUE	YELLOW	LIGHT BLUE	
	WHITE	BROWN	YELLOW GREEN	BLUE WHITE	
	GREEN	GRAY	PURPLE	TURQUOISE	
	RED	ORANGE	PINK		

Wiring Diagram

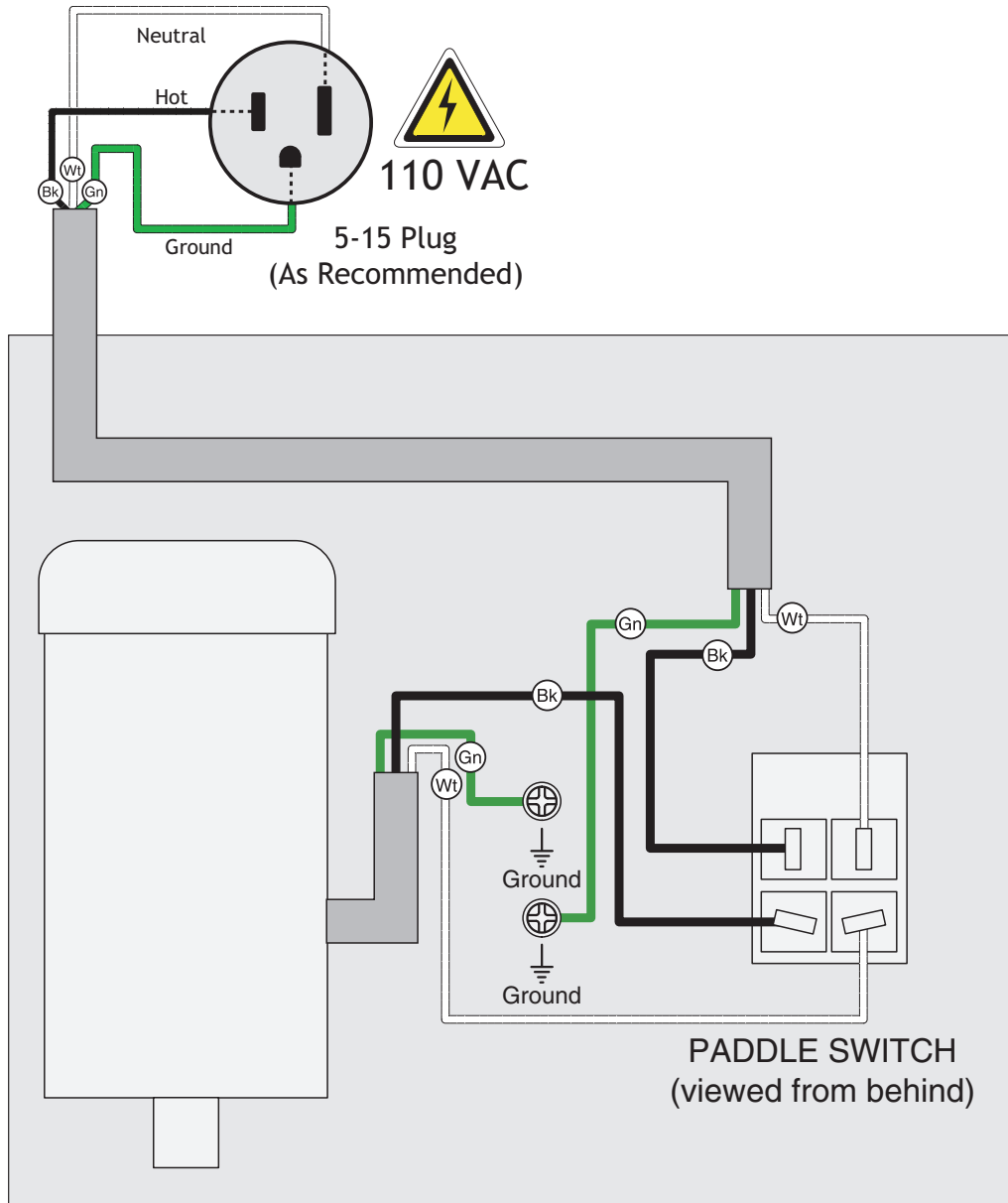

NOTICE
These motor wiring diagrams are current at the time of printing; however, always default to the diagram on the inside of the junction box cover if it does not match this diagram, as it will reflect any changes since this manual was printed!



Parts List

REF	PART #	DESCRIPTION
1	X1829001	TABLE
2	X1829002	FENCE
2A	X1829002A	FENCE ASSEMBLY
3	X1829003	FENCE PLATE
4	X1829004	FENCE TILTING HANDLE
5	X1829005	FLAT WASHER 8MM
6	X1829006	RIGHT LINK
7V2	X1829007V2	LEFT LINK (TAPERED) V2.03.18
8V2	X1829008V2	PLATE SHAFT (TAPERED) V2.03.18
9V2	X1829009V2	BRACKET SHAFT (TAPERED) V2.03.18
10	X1829010	LIMIT PLATE
11	X1829011	BLOCK
12	X1829012	SHAFT
13	X1829013	FENCE BRACKET
14	X1829014	FENCE SLIDING HANDLE
15	X1829015	FENCE SUPPORT
16	X1829016	LOCKING PLATE
17	X1829017	TABLE PIN
18	X1829018	FRAME PIN
19	X1829019	BRACKET
20	X1829020	INFEED TABLE
21	X1829021	TABLE FRAME
22	X1829022	SUPPORT PLATE
23	X1829023	KNOB
23-1	X1829023-1	KNOB BOLT
24	X1829024	MOTOR 1-1/2HP 110V UNIVERSAL
24-1	X1829024-1	CARBON BRUSH SET
24-2	X1829024-2	BRUSH COVER
24-3	X1829024-3	RING TERMINAL
24-4	X1829024-4	SPADE TERMINAL
25	X1829025	MOTOR PULLEY
26	X1829026	MOTOR MOUNTING PLATE
27	X1829027	CORD CLAMP
28	X1829028	COMPRESSION SPRING
29	X1829029	BLADE GUARD
29-1	X1829029-1	RUBBER BUMPER
30	X1829030	TORSION SPRING
31	X1829031	PIN
33	X1829033	SHAFT
34	X1829034	CUTTERHEAD
35	X1829035	KNIVES 2-PC SET 6 x 7/8 x 3/32"
36	X1829036	KNIFE CLAMP
37	X1829037	DRIVE PULLEY
39	X1829039	JACK SCREW M4-.7 X 10
40	X1829040	BUTTON HD CAP SCR 1/4-20 X 5/8
41	X1829041	FAN PULLEY
42	X1829042	SPACER
43	X1829043	FAN SHAFT
44	X1829044	CHIP BLOWER MOUNTING PLATE
44-1	X1829044-1	EXT RETAINING RING 26MM
45	X1829045	IMPELLER
46	X1829046	CHIP EXHAUST
47	X1829047	CHIP COLLECTOR
48	X1829048	BASE BOTTOM

REF	PART #	DESCRIPTION
49	X1829049	ALIGNMENT PIN
50	X1829050	PUSH BLOCKS
51	X1829051	PADDLE SWITCH
52	X1829052	BALL BEARING 6000ZZ
53	X1829053	SET SCREW M6-1 X 10
54	X1829054	CAP SCREW M6-1 X 12
55	X1829055	LOCK WASHER 6MM
56	X1829056	FLAT WASHER 6MM
57	X1829057	PHLP HD SCR M5-.8 X 10
58	X1829058	FLAT WASHER 5MM
59	X1829059	CAP SCREW M4-.7 X 10
60	X1829060	TAP SCREW M6 X 12
61	X1829061	PHLP HD SCR M6-1 X 20
62	X1829062	LOCK WASHER 8MM
63	X1829063	CAP SCREW M8-1.25 X 20
64	X1829064	CAP SCREW M6-1 X 20
65	X1829065	HEX BOLT M5-.8 X 25
66	X1829066	HEX NUT M5-.8
67	X1829067	CAP SCREW M6-1 X 55
68	X1829068	HEX NUT M6-1
69	X1829069	CAP SCREW M6-1 X 30
70	X1829070	RIBBED V-BELT 171J5 NK
71	X1829071	HEX NUT M8-1.25
72	X1829072	HEX BOLT M8-1.25 X 35
73	X1829073	SHAFT RETAINER M10
74	X1829074	E-CLIP 6MM
75	X1829075	SET SCREW M6-1 X 30
76	X1829076	CAP SCREW M6-1 X 30
77	X1829077	SET SCREW M6-1 X 35
78	X1829078	SET SCREW M6-1 X 16
79	X1829079	PHLP HD SCR M5-.8 X 8
81	X1829081	PHLP HD SCR M4-.7 X 10
82	X1829082	EXT TOOTHED WASHER 4MM
83	X1829083	LOCK WASHER 5MM
84	X1829084	WIRE NUT
85	X1829085	EXT RETAINING RING 12MM
86	X1829086	BALL BEARING 6201ZZ
87	X1829087	STR SNAP-IN STRAIN RELIEF 5/8"
89	X1829089	POWER CORD 16G 3W 5-15 72"
90	X1829090	SPADE TERMINAL
91	X1829091	RING TERMINAL
92	X1829092	FAN RIBBED V-BELT V1.25-7A
93	X1829093	DUST PORT
94	X1829094	FLAT WASHER 5MM
95	X1829095	DUST COLLECTION BAG
96	X1829096	HEX NUT M6-1
97	X1829097	CLAMP 60MM
98	X1829098	SOLID PIN 4.5 X 20MM
99	X1829099	CLAMP HANDLE
100	X1829100	SWING BOLT M6-1 X 50
102	X1829102	HEX WRENCH 6MM
103	X1829103	HEX WRENCH 4MM
104	X1829104	BASE
105	X1829105	SWITCH MOUNTING PLATE

Parts List (continued)

REF	PART #	DESCRIPTION
106	X1829106	RIGHT RUBBER FOOT
107	X1829107	LEFT RUBBER FOOT
108	X1829108	GUARD PLATE
109	X1829109	CUTTERHEAD COVER
110	X1829110	PHLP HD SCR M5-.8 X 6

REF	PART #	DESCRIPTION
111	X1829111	CAP SCREW M6-1 X 8
112	X1829112	FENDER WASHER 5MM
113	X1829113	INFEED TABLE SUPPORT ARM
114	X1829114	CHIP COLLECTOR COVER PLATE
115	X1829115	WIRE RESTRAINT

Labels

⚠ WARNING

Safety labels warn about machine hazards and how to prevent machine damage or injury. The owner of this machine **MUST** maintain the original location and readability of all labels on this machine. If any label is removed or becomes unreadable, **REPLACE** that label before allowing the machine to enter service again. Contact Woodstock International, Inc. at (360) 734-3482 or www.shopfoxtools.com to order new labels.

NOTE: Align this label with cutterhead throat.

121

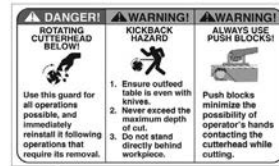
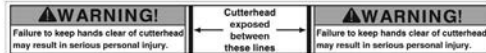

117

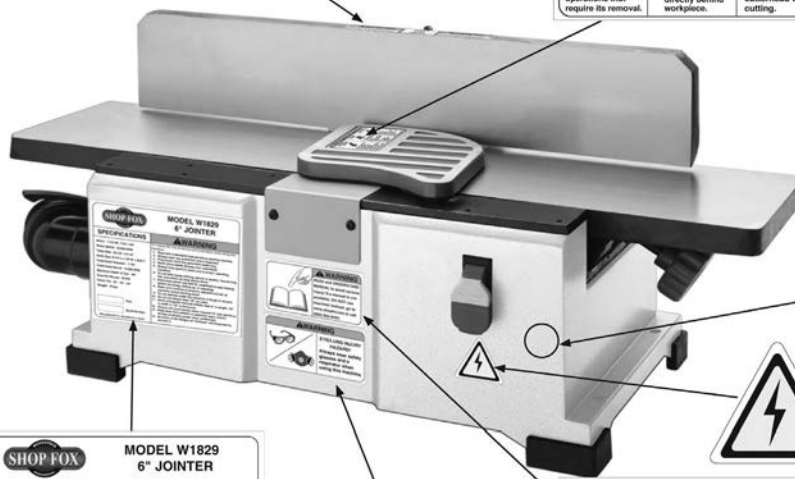

122

119

120

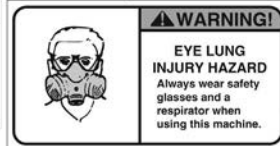

118

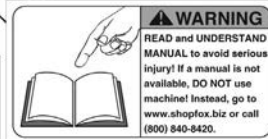

116

REF	PART #	DESCRIPTION
116	X1829116	READ MANUAL LABEL
117	X1829117	CUTTERHEAD GUARD LABEL
118	X1829118	EYE/LUNG HAZARD LABEL
119	X1829119	ELECTRICITY LABEL

REF	PART #	DESCRIPTION
120	X1829120	MACHINE ID LABEL
121	X1829121	CUTTERHEAD EXPOSURE LABEL
122	X1829122	SHOP FOX WHITE(M1006)



Warranty Registration

Name _____
 Street _____
 City _____ State _____ Zip _____
 Phone # _____ Email _____ Invoice # _____
 Model # _____ Serial # _____ Dealer Name _____ Purchase Date _____

The following information is given on a voluntary basis. It will be used for marketing purposes to help us develop better products and services. Of course, all information is strictly confidential.

- How did you learn about us?
 Advertisement Friend Local Store
 Mail Order Catalog Website Other:
- How long have you been a woodworker/metalworker?
 0-2 Years 2-8 Years 8-20 Years 20+ Years
- How many of your machines or tools are Shop Fox?
 0-2 3-5 6-9 10+
- Do you think your machine represents a good value? Yes No
- Would you recommend Shop Fox products to a friend? Yes No
- What is your age group?
 20-29 30-39 40-49
 50-59 60-69 70+
- What is your annual household income?
 \$20,000-\$29,000 \$30,000-\$39,000 \$40,000-\$49,000
 \$50,000-\$59,000 \$60,000-\$69,000 \$70,000+
- Which of the following magazines do you subscribe to?
 Cabinet Maker Popular Mechanics Today's Homeowner
 Family Handyman Popular Science Wood
 Hand Loader Popular Woodworking Wooden Boat
 Handy Practical Homeowner Woodshop News
 Home Shop Machinist Precision Shooter Woodsmith
 Journal of Light Cont. Projects in Metal Woodwork
 Live Steam RC Modeler Woodworker West
 Model Airplane News Rifle Woodworker's Journal
 Modeltec Shop Notes Other:
 Old House Journal Shotgun News

9. Comments: _____

CUT ALONG DOTTED LINE

FOLD ALONG DOTTED LINE

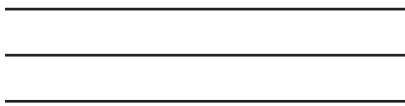

Place
Stamp
Here



WOODSTOCK INTERNATIONAL INC.
P.O. BOX 2309
BELLINGHAM, WA 98227-2309



FOLD ALONG DOTTED LINE

TAPE ALONG EDGES--PLEASE DO NOT STAPLE



WARRANTY

Woodstock International, Inc. warrants all Shop Fox machinery to be free of defects from workmanship and materials for a period of two years from the date of original purchase by the original owner. This warranty does not apply to defects due directly or indirectly to misuse, abuse, negligence or accidents, lack of maintenance, or reimbursement of third party expenses incurred.

Woodstock International, Inc. will repair, replace, or arrange for a dealer refund at its expense and at its option, the Shop Fox machine or machine part, which in proper and intended use has proven to be defective, provided that the original owner returns the product prepaid to an authorized warranty or repair facility as designated by our Bellingham, Washington office with proof of their purchase of the product within two years, and provides Woodstock International, Inc. reasonable opportunity to verify the alleged defect through inspection. If it is determined there is no defect, or that the defect resulted from causes not within the scope of Woodstock International Inc.'s warranty, then the original owner must bear the cost of storing and returning the product.

This is Woodstock International, Inc.'s sole written warranty and any and all warranties that may be implied by law, including any merchantability or fitness, for any particular purpose, are hereby limited to the duration of this written warranty. We do not warrant that Shop Fox machinery complies with the provisions of any law, acts or electrical codes. We do not reimburse for third party repairs. In no event shall Woodstock International, Inc.'s liability under this limited warranty exceed the purchase price paid for the product, and any legal actions brought against Woodstock International, Inc. shall be tried in the State of Washington, County of Whatcom. We shall in no event be liable for death, injuries to persons or property or for incidental, contingent, special or consequential damages arising from the use of our products.

Every effort has been made to ensure that all Shop Fox machinery meets high quality and durability standards. We reserve the right to change specifications at any time because of our commitment to continuously improve the quality of our products.



High Quality Machines and Tools

Woodstock International, Inc. carries thousands of products designed to meet the needs of today's woodworkers and metalworkers.

Ask your dealer about these fine products:

BROSWA
PRECISION STOP BLOCK

JOINTER PAL[®]

Rotacator[®]

THE REBEL[®]

DURASTICK[®]

Gutmann[®]

BOARD BUDDIES[®]

Junglee[®]

PLANER PAL[®]



PARROT VISE[®]

SLICKPLANE[®]

PRO-STIK[®]
ABRASIVE BELT & DISC CLEANER

ACCU-SHARP[®]



STEELEX[®]
PLUS

STEELEX[®]
FINE TOOLS

Aluma-Classic[®]

WHOLESALE ONLY

WOODSTOCK INTERNATIONAL, INC.

Phone: (360) 734-3482 • Fax: (360) 671-3053 • Toll Free Fax: (800) 647-8801

P.O.Box 2309 • Bellingham, WA 98227

SHOPFOX.BIZ