





kēvo CONVERT

Required tools

Ruler



Phillips screwdriver



Existing key



Parts in the box

Black mounting plate kit

Mounting plate

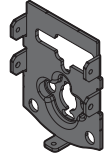

Adapter



Interior assembly screws



Mounting plate screws



Interior cover screws



Gold mounting plate kit

Mounting plate

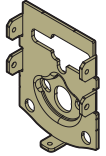

Adapter



Interior assembly screws



Mounting plate screws



Interior cover screws



Silver mounting plate kit

Mounting plate

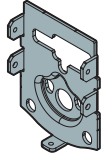

Adapters



Interior assembly screws





Mounting plate screws



Interior cover screws

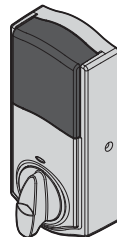
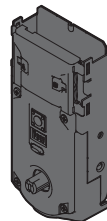

<p>Interior cover</p> 	<p>Interior assembly</p> 	<p>Battery pack</p> 	<p>AA batteries</p> 
---	---	---	---

1 Make sure your existing deadbolt is compatible.

If you have a standard deadbolt mounted separately from the handle below it, it is compatible with Kevo Convert.

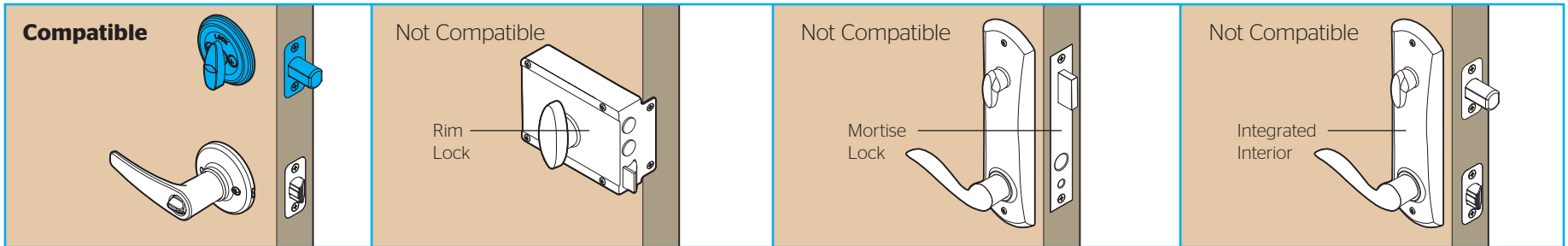

2 Measure the thickness of your door.

Measure to confirm that your door is either 1-3/8" or 1-3/4" (35 mm or 44 mm) thick.

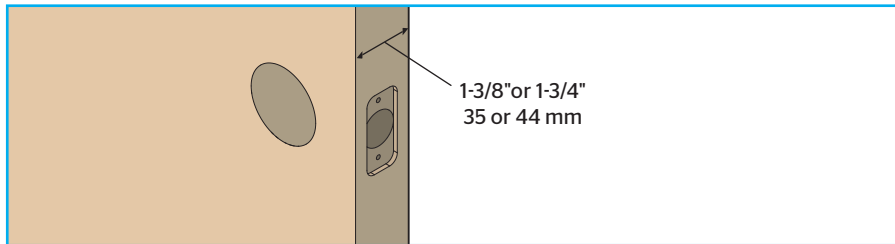

3 Disassemble your existing deadbolt.

A Make sure your door is open and extend your latch bolt.

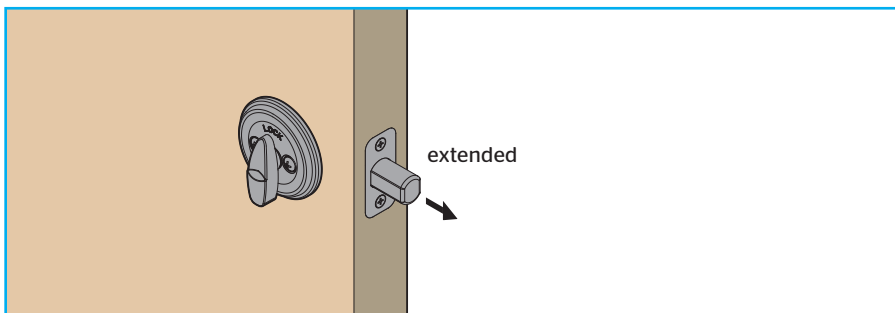

B Remove all existing deadbolt hardware from the interior side of your door. Keep your deadbolt exterior in place.

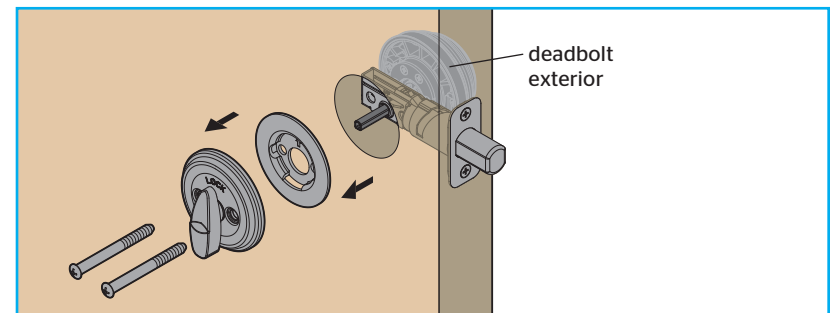

4

Determine the parts needed for your door.

For a list of compatible deadbolt models, please see page 11.

Look at the hole in your door.
What shape is your torque blade (the part sticking out through the latch)?

D-shape

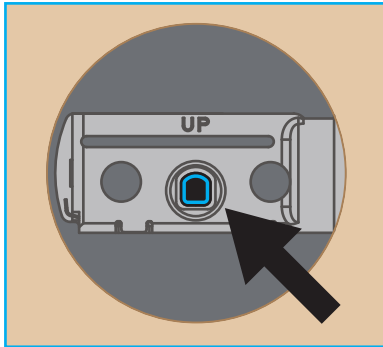

Kwikset and Weiser deadbolts:

Use the black mounting plate kit for your door.

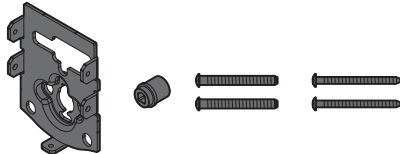

Baldwin Reserve and Baldwin Prestige deadbolts:

Use the gold mounting plate kit for your door.

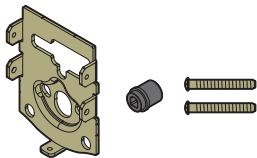

Slanted rectangle

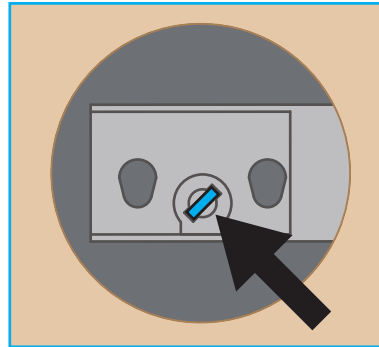

Schlage deadbolts:

Use the silver mounting plate kit for your door.

You will need the silver adapter.

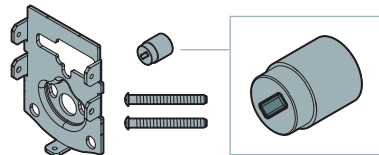

Horizontal rectangle

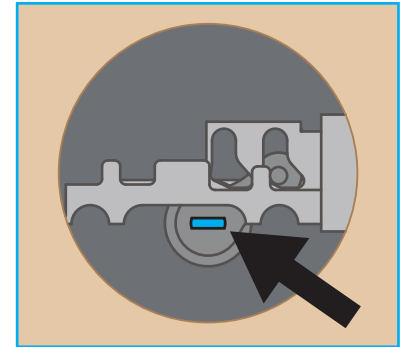

Schlage deadbolts:

Use the silver mounting plate kit for your door.

You will need the gold adapter.

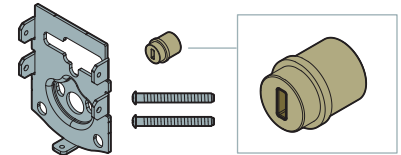

5 Install the mounting plate and test your latch.

- A** Place the mounting plate on the door so that the torque blade inserts through the center hole.

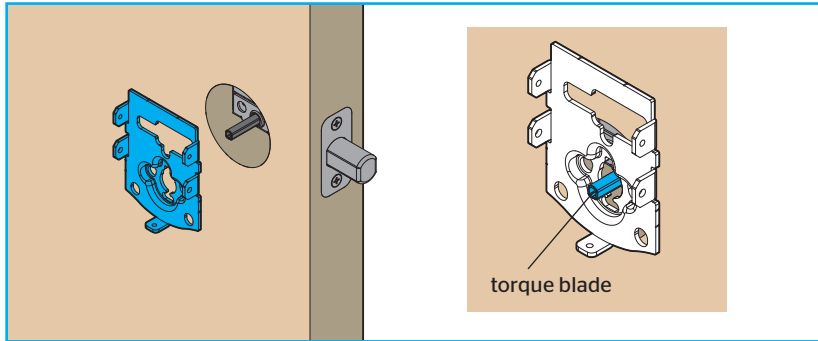

Note: A D-shaped torque blade is shown, but installation is the same for all models.

- B** Secure the mounting plate with the mounting screws.

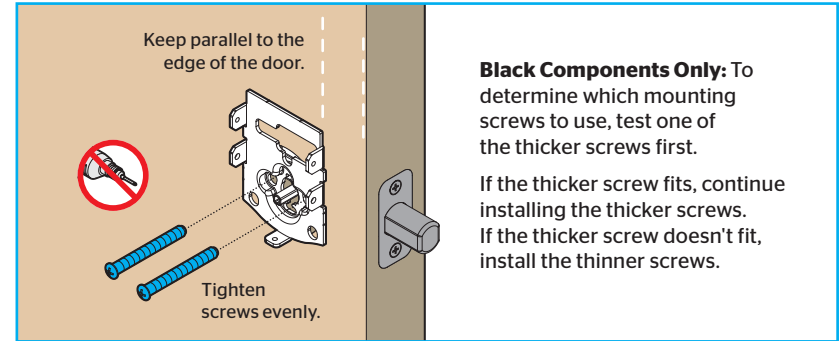

- C** Insert your key and test the latch for smooth operation.

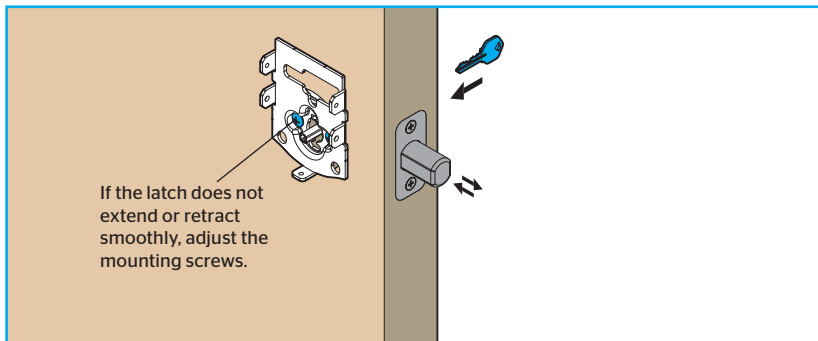

- D** Remove your key and make sure the bolt is fully extended.

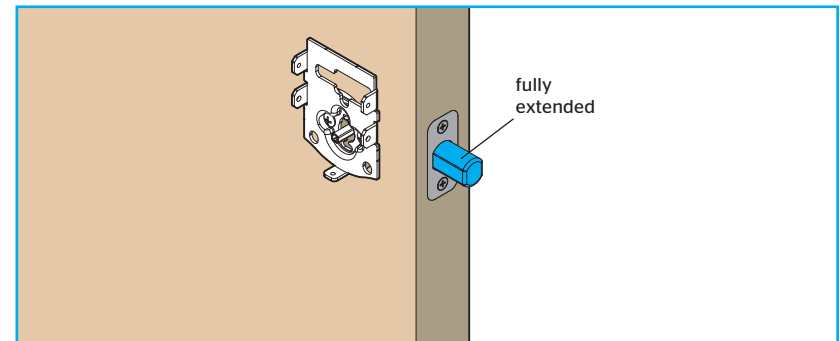

6 Install the interior assembly.

A Prepare the interior assembly.

- a** Make sure the turnpiece is in the vertical position.

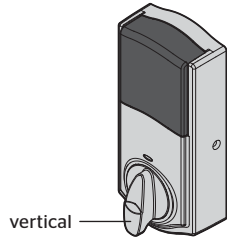

- b** Remove the interior cover.

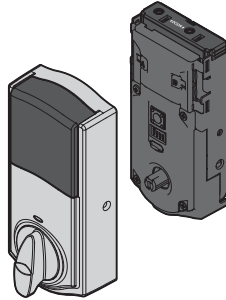

- c** Make sure shaft is oriented as shown. If needed, rotate the shaft to this position.

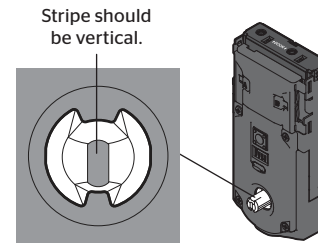

- d** Remove the battery pack.

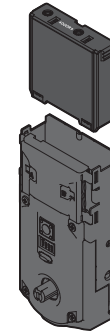

B Install the adapter on the interior assembly.

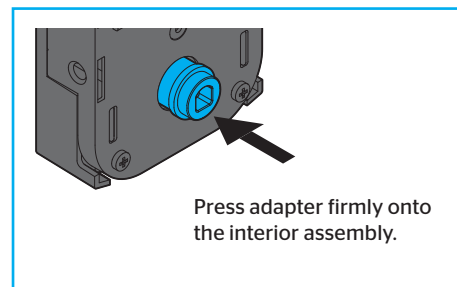
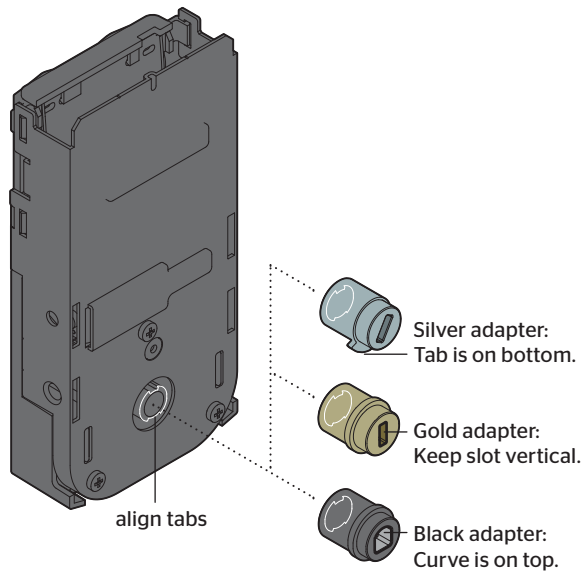

6

Install the interior assembly (continued).



SCHLAGE DEADBOLTS ONLY:

Look at your mounting plate.
Is your latch bolt to the left or right of your mounting plate?

Left

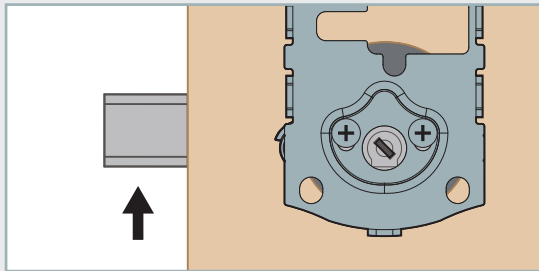

No adjustment is required.
Proceed to the next page.

Right

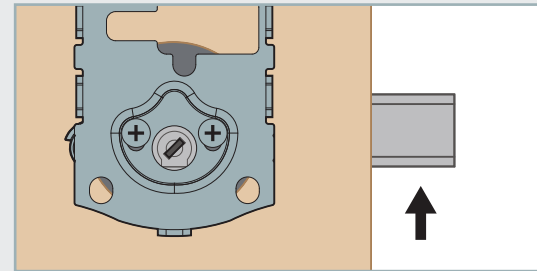

On your interior assembly, flip switch #2
to the top position.

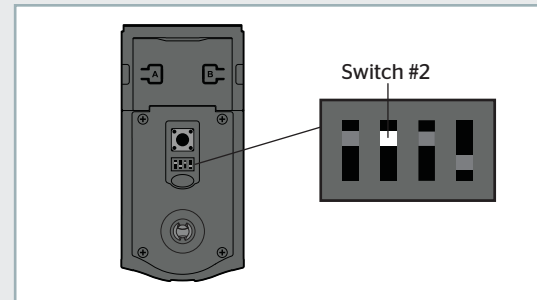

6 Install the interior assembly (continued).

C Install the interior assembly onto the mounting plate.

a Align the adapter with the torque blade.

Schlage deadbolts only:

You may need to rotate the adapter to align with the torque blade.

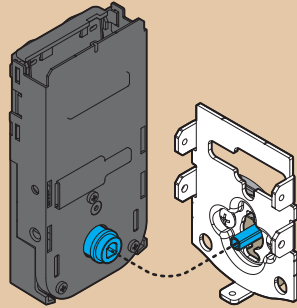

b Secure with two (2) interior assembly screws.

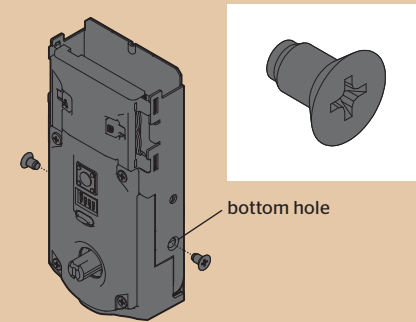

7 Perform the door handing process.

This step will teach the lock the orientation of your door and is crucial for lock operation.

A Install 4 AA batteries in the battery pack.

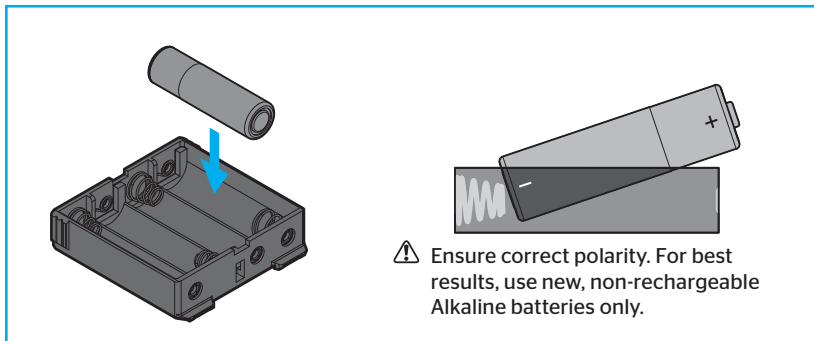

B **IMPORTANT:** Make sure the door is open. Insert the battery pack while **PRESSING AND HOLDING** the Program button. Release the button when the battery pack is all the way inside the lock interior.

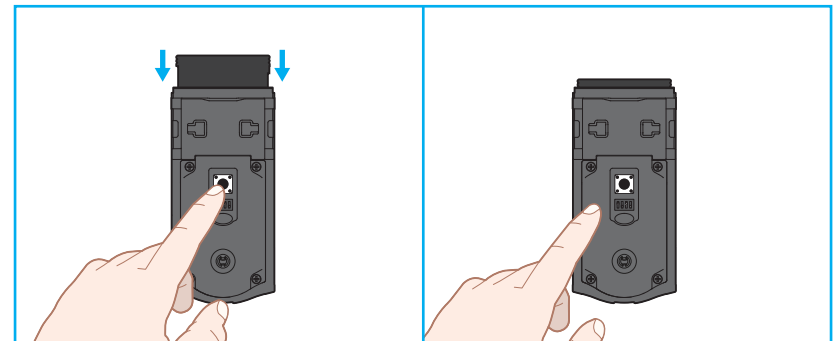

C **IMPORTANT:** The Status LED will flash red and green, and the lock will beep. Press and release the Program button again. The latch bolt will retract and extend on its own.

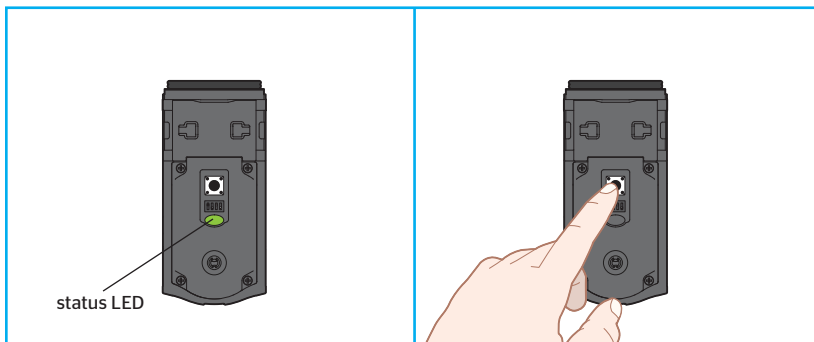

D Did the latch bolt retract and extend on its own?

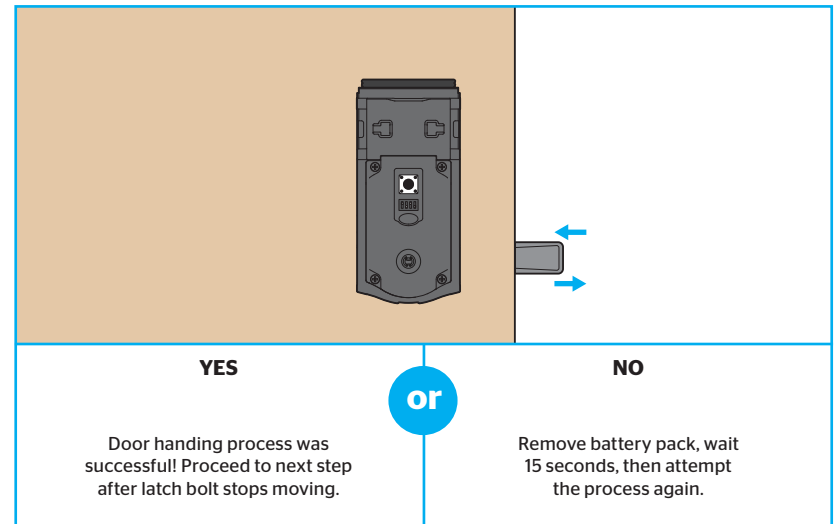

8 Download the Kevo app and set up your smartphone.

A Download the Kevo app at kwikset.com/kevo/app or scan the QR code below.



B Follow the instructions inside the app to create an account, enroll your first smartphone and send eKeys to family and friends.



9

Install the interior cover.

Important information about the interior cover:

The interior cover will be secured by three screws to prevent someone from removing the battery or tampering with your lock's settings.

The window on the interior cover is locked by default.

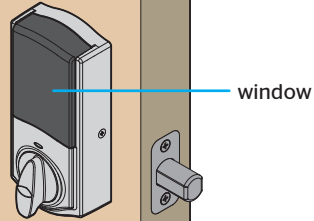

If the window is unlocked, it can slide up for more convenient access to programming buttons while the cover is installed.

Note: The interior cover and screws must be removed for battery pack access.

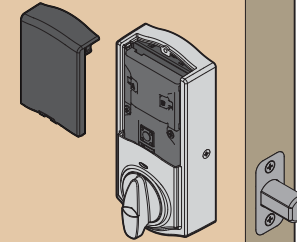

If you want to keep the window locked:

a Install the cover.

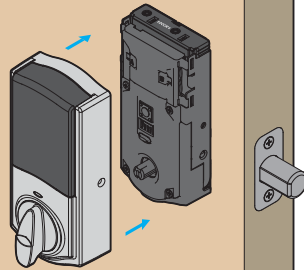

b Secure the cover with three (3) interior cover screws.

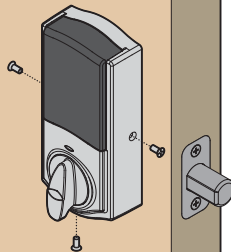

If you want to unlock the window:

a Remove the security screw.

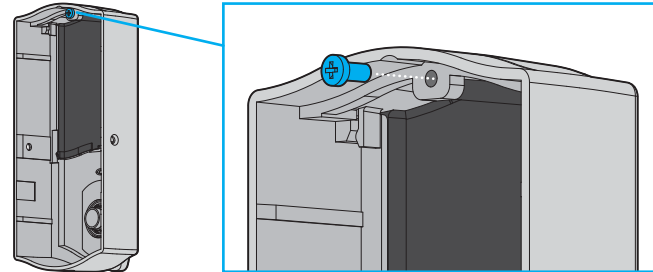

b Install the cover.

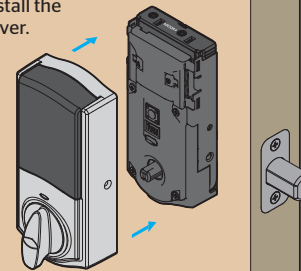

c Secure the cover with three (3) interior cover screws.

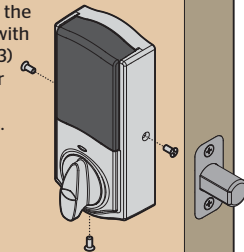

Kevo Convert Compatibility Chart

Kevo Convert is compatible with the following models:

Kwikset

<i>Model</i>	<i>Mounting plate required</i>	<i>Screws required</i>
158	Black	Thick
660	Black	Thin
660M	Black	Thin
780	Black	Thick
816	Black	Thick
980	Black	Thick
980AUD	Black	Thick
993	Black	Thick

Weiser

<i>Model</i>	<i>Mounting plate required</i>	<i>Screws required</i>
GDC9471	Black	Thin
GCD9471	Black	Thick
GCD9571	Black	Thick
SSD9471	Black	Thick

Schlage

<i>Model</i>	<i>Mounting plate required</i>	<i>Adapter required</i>
B360N	Silver	Gold
B560P	Silver	Silver
B60N	Silver	Silver
B660P6	Silver	Silver
B760P	Silver	Silver

Baldwin

<i>Model</i>	<i>Mounting plate required</i>	<i>Adapter required</i>
All Baldwin Prestige 380 Deadbolts	Gold	Black
All Baldwin Reserve single cylinder deadbolts	Gold	Black

Kevo Convert at a Glance

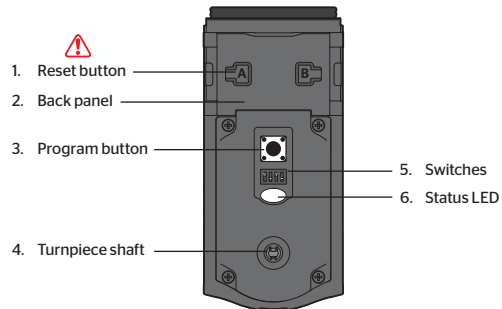

1. ⚠️ Only use to reset Kevo Convert to delete all eKeys from your system. See "System Reset" for more information.
2. Where all the programming features are located.
3. Use to enroll smartphones.
4. Engages with turnpiece when interior cover is installed. When the cover is removed, the turnpiece shaft can be used to manually lock and unlock the door.
5. Use to enable and disable the Status LED, Invert, Audio, and Auto-Lock.
6. Communicates whether the door is locked or unlocked and flashes red for a low battery alert. Can be turned on and off by Switch #1.

Kevo-Compatible Devices

Smartphones and Smart Devices

A Kevo-compatible smartphone (or other mobile internet-connected device or tablet) must have Bluetooth Smart Ready/ Bluetooth 4.0 and an app specific to the device must be installed. Find out if your device is compatible at www.kwikset.com/kevo/devices.



Standard Key

Always make sure you have access to your standard key.

Switches

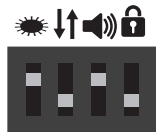

Switch 1 Status LED

Door lock status LED blinks every 6 seconds. ON position is factory default.

Switch 2 ⚠️ Invert

Only used for right-handed doors that have installed silver components. See page 6 for details.

Switch 3 Audio

Beeping sound is heard during programming and normal operation. ON position is factory default.

Switch 4 ⚠️ Auto-Lock

Automatically re-locks door 30 seconds after unlocking. OFF position is factory default.

⚠️ **CAUTION:** With this feature enabled, it is possible to lock yourself outside if you don't have an enrolled smartphone or standard key with you.

Status LED Notifications

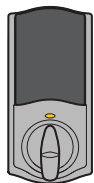

Amber flash
Door is locked



Green flash
Door is unlocked.

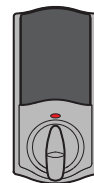

Red flash
The 4 AA batteries in the Kevo interior are low and need to be replaced.

System Reset

⚠️ **WARNING:** Resetting your Kevo system will restore your lock to factory settings and delete all smartphones from Kevo's memory.

If you wish to perform a system reset, **press and hold** the Reset button on the back panel for 10 seconds until the lock beeps.

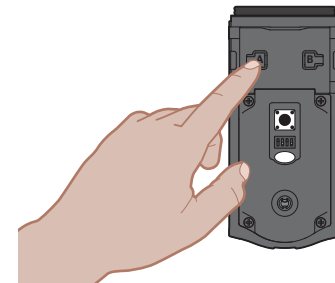

After a system reset, you will need to re-enroll your Owner phone. You will still be able to send eKeys at no charge to anyone who previously had an active eKey at the time of reset.

Advanced Features

History Log

A history of the lock's activity may be viewed through the Kevo app or by logging into the web portal: www.mykevo.com.

Notifications

The Kevo app can send notifications when the door is locked and unlocked by eKey holders. You can choose to receive the system's default notifications or set up custom notifications to monitor a specific user or time frame.

Dual Factor Authentication

Kevo features an optional, added-security passcode that you can enable inside the app to be used in addition to the app's password. Enabling the passcode will require you to enter a 4-digit PIN whenever you access the app, and it protects your Kevo account against unauthorized changes when your phone is unlocked.

Kevo Plus

With Kevo Plus, you will be able to lock and unlock your home and check whether your door is locked or unlocked when you are away from home. You can upgrade to Kevo Plus inside the Kevo app. Visit www.kwikset.com/kevo/kevo-plus for more information.

Connect Smart Products

Connect Kevo to select smart products. In the Kevo app, tap the gear icon to connect to smart products (iOS only: select "Preferences"). Visit www.kwikset.com/kevo/support for more information.

Important Safeguards

1. Read all instructions in their entirety.
2. Familiarize yourself with all warning and caution statements.
3. Remind all family members of safety precautions.
4. Always have access to your lock's standard key.
5. If using the Auto-Lock feature, make sure to have your smartphone or standard key with you to prevent locking yourself out.
6. Replace low batteries immediately.

Preventing Inadvertent Unlocking of Your Door

 **WARNING:** Failure to follow these safeguards could result in your lock opening inadvertently.

1. Restrict access to your Kevo lock's back panel and routinely check your settings to ensure they have not been altered without your knowledge.
2. Protect the password to your Kevo app and web portal accounts.
3. When sending an eKey, always double-check that you are sending it to the correct recipient.
4. Protect and restrict access to your smartphone so that your app settings cannot be altered without your knowledge.
5. Enable the Kevo app's security passcode so that your app settings cannot be altered without your knowledge.
6. When sending eKeys, be aware of the difference between an Admin user and other users in the system: an Admin user can send, disable and delete eKeys.
7. If your smartphone is lost or stolen, use the Kevo web portal (www.mykevo.com) to disable it.

 **WARNING:** This Manufacturer advises that no lock can provide complete security by itself. This lock may be defeated by forcible or technical means, or evaded by entry elsewhere on the property. No lock can substitute for caution, awareness of your environment, and common sense. Builder's hardware is available in multiple performance grades to suit the application. In order to enhance security and reduce risk, you should consult a qualified locksmith or other security professional.