

Ductless Mini-Split System Installation

Tools Required

- Philips Screw Driver
- Level
- Drill
- 2 ½ inch Hole Saw
- Allen Wrench 5.5 & 6
- Vacuum Pump
- 410 A Gauge
- Torque Wrench

STEP 1 - Indoor Unit (Evaporator)

Find a suitable location.

- Install the indoor unit on a level & structurally sound wall that is not subject to vibration.
- The inlet and outlet ports on indoor unit should not be obstructed; the air should be able to freely circulate throughout the coverage area.
- Do not install the unit near a heat source, steam, or flammable gas/fumes.
- Do not install unit in direct sunlight.
- Install the unit where connection between indoor & outdoor unit is as easy as possible.
- Install the unit where it is easy to drain the condensed water.
- Install evaporator at least 4 inches from the ceiling, or 8 feet for high ceilings.

STEP 2 - Outdoor Unit (Condenser)

Find the perfect location for the condenser unit.

OUTDOOR UNIT

- Do not install the outdoor unit near sources of heat, steam or flammable gas.
- Do not install the unit in too windy or dusty places.
- Do not install the unit where people often pass. Select a place where the air discharge and operating sound level will not disturb the neighbours.
- Avoid installing the unit where it will be exposed to direct sunlight (otherwise use a protection, if necessary, that should not interfere with the air flow).
- Leave the spaces as shown in the picture for the air to circulate freely.
- Install the outdoor unit in a safe and solid place.
- If the outdoor unit is subject to vibration, place rubber gaskets onto the feet of the unit.

Installation Diagram

minimum space to be left (mm) showing in the picture

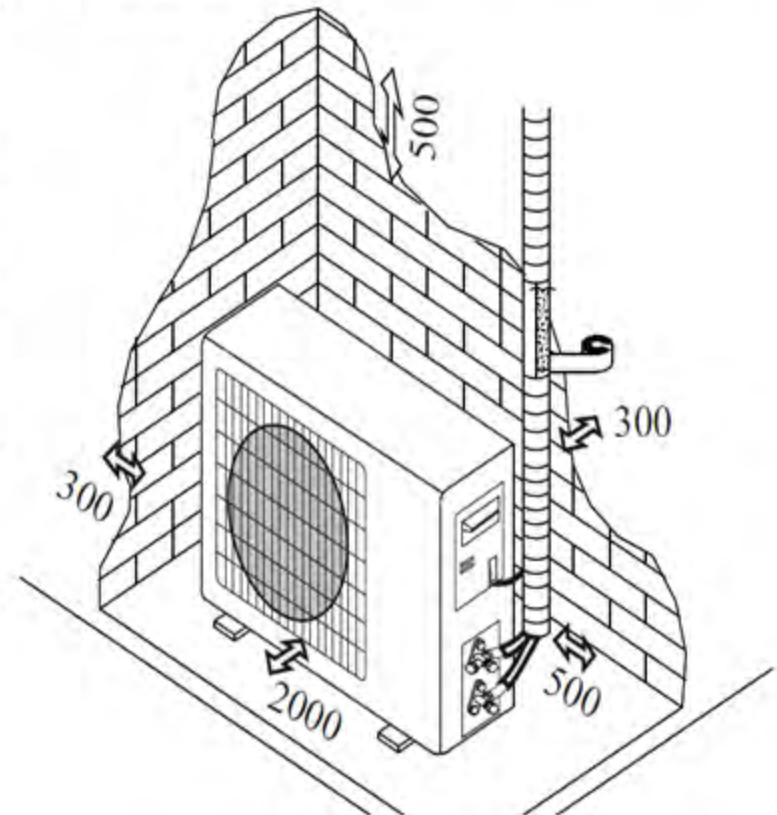

Maximum Height & Distances

Installation Diagram

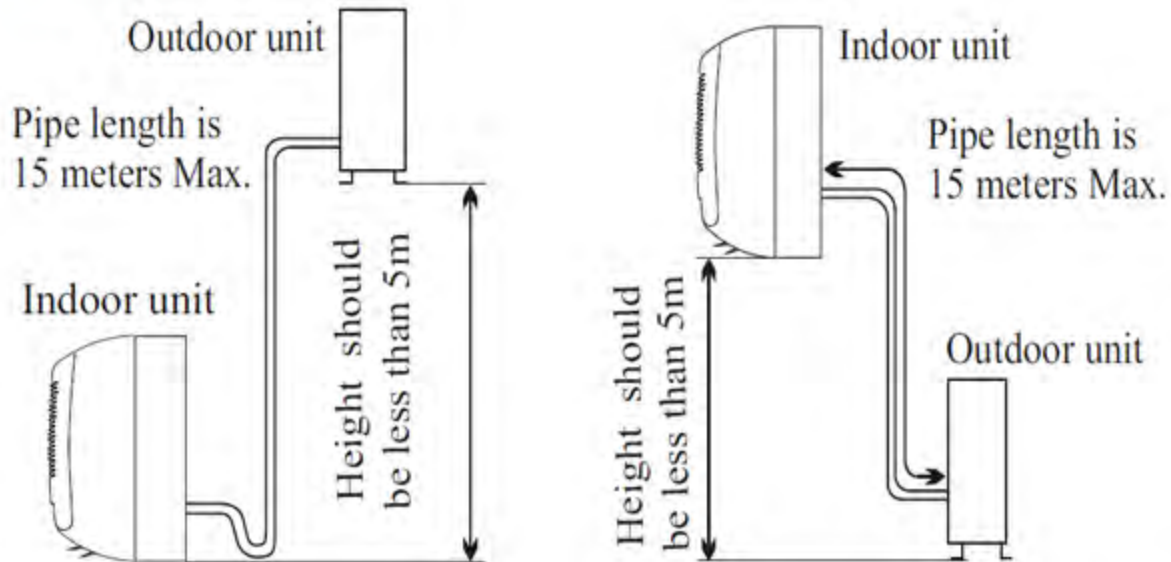

Only persons and/or companies qualified and experienced in the installation, service and repair of refrigerant products should be permitted to do so. The purchaser must ensure that the person and/or company who is to install, service or repair this air conditioner has qualifications and experience in refrigerant products.

STEP 3

Remove Mounting Plate from Indoor Unit.



STEP 4

Find secure location for the Mounting Plate and mark the holes. *Note: Be sure that the plate is level.



STEP 5

Attach Mounting Plate to structure.



STEP 6

Drill a 2 ½ inch Hole

*Note: The hole must be drilled on an angle of about 30 degrees; the exterior opening should be at least ¼ inch lower than the interior opening.



STEP 7

Install supplied wall sleeve.



STEP 8

Prepare Indoor Unit refrigerant piping connections.



INSTALLATION MANUAL---Installation of the Indoor unit

Refrigerant piping connection

The piping can be run in the 3 directions indicated by numbers in the picture . When the piping is run in direction 1or3, cut a notch along the groove on the side of the indoor unit with a cutter.

Run the piping in the direction of the wall hole and bind the copper pipes , the drain pipe and the power cables together with the tape with the drain pipe at the bottom, so that water can flow freely.

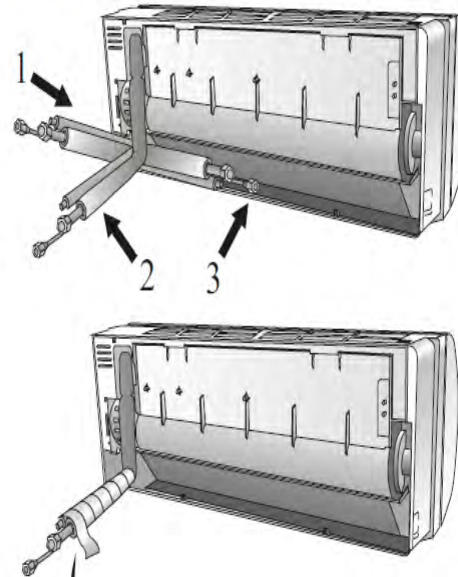

STEP 9

Remove the seal caps from the indoor refrigerant lines.

*Note: Nitrogen charge may be released & a hissing sound may be heard when the first seal cap is removed.



STEP 10

Guide the line set through the 2 ½ inch hole.



*Note: Refrigerant Pipes

Connecting the pipes

- Do not remove the cap from the pipe until connecting it, to avoid dampness or dirt from entering.
- If the pipe is bent or pulled too often, it will become stiff. Do not bend the pipe more than three times at one point.
- When extending the rolled pipe, straighten the pipe by unwinding it gently as shown in the picture.

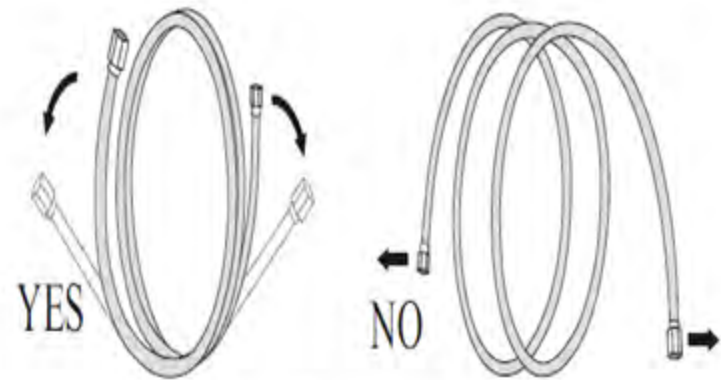

Extending the rolled pipe

STEP 11

Remove the seal caps from the refrigerant lines.



STEP 12

Tighten connections using wrenches working in opposite direction. *Note: For best result use Torque Wrench.



STEP 13

Connect the supplied drain line extension.



STEP 14

- A. Arrange the pipes, cables & drain hose.
- B. Lag the pipe joints with insulating material, securing it with supplied UV vinyl tape.
- C. Run the bundled pipe, cables & drain hose back through the 2 ½ inch hole.



*Note: Always keep drain line at the bottom of bundle.



Indoor unit condensed water drainage

The indoor unit condensed water drainage is fundamental for the success of the installation.

1. Place the drain hose below the piping, taking care not to create siphons.
2. The drain hose must slant downwards to aid drainage.
3. Do not bend the drain hose or leave it protruding or twisted and do not put the end of it in water. If an extension is connected to the drain hose, ensure that it is lagged when it passes into the indoor unit.
4. If the piping is installed to the right, the pipes, power cable and drain hose must be lagged and secured onto the rear of the unit with a pipe connection.
 - 1) Insert the pipe connection into the relative slot.
 - 2) Press to join the pipe connection to the base.

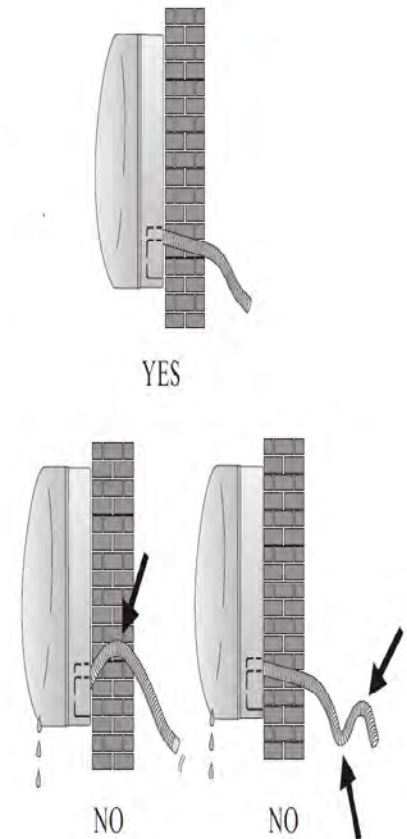

STEP 15

Reconnect Indoor Unit to Mounting Plate.



STEP 16

Install vibration pads and secure Outdoor Unit.



***Note: Optional L Bracket System**

The bracket must be secured to the structure of the building using the proper industry standard anchors for heavy loads. The condenser must be accessible for service.



STEP 17 – Outdoor Unit (Condenser) Connection

Remove valve cover.



STEP 18

Remove seal cap protector.



*Note: Pipe Connection

CONNECTING THE PIPES

Screw the flare nuts to the outdoor unit coupling with the same tightening procedures described for the indoor unit.

To avoid leakage, pay attention to the following points:

1. Tighten the flare nuts using two wrenches. Pay attention not to damage the pipes.
2. If the tightening torque is not sufficient, there will probably be some leakage. With excessive tightening torque there will also be some leakage, as the flange could be damaged.
3. The surest system consists in tightening the connection by using a fix wrench and a torque wrench: in this case use the table on page 21.

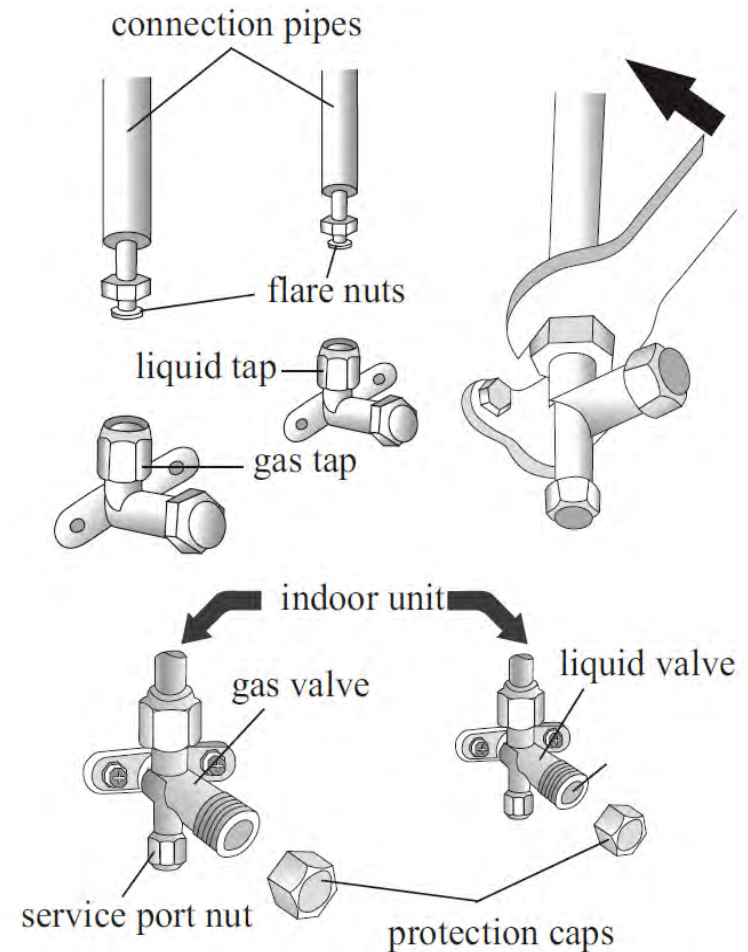

STEP 19

Connect refrigerant lines to outdoor unit valves.



STEP 20

Bleed/ Purge system using a Vacuum Pump.

BLEEDING

Air and humidity left inside the refrigerant circuit can cause compressor malfunction. After having connected the indoor and outdoor units, bleed the air and humidity from the refrigerant circuit by using a vacuum pump.

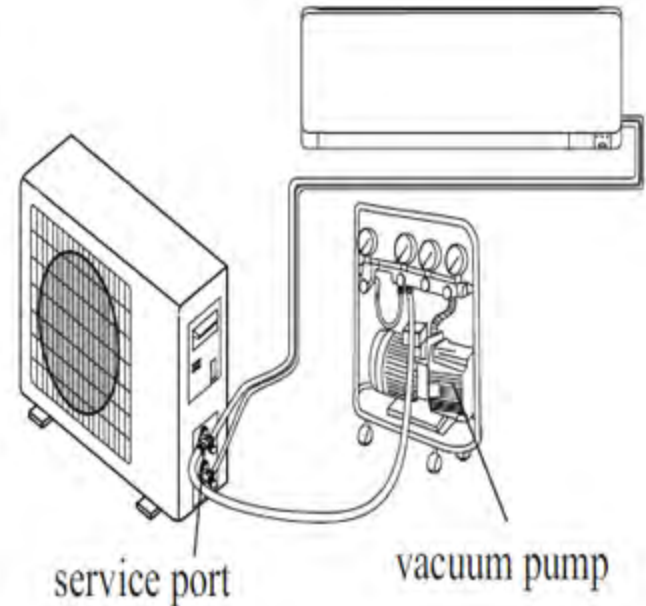

*Note: Vacuum Bleeding

BLEEDING

The air and humidity left inside the refrigerant circulation can cause compressor malfunction. After having connected the indoor and outdoor units, bleed the air and humidity from the refrigerant circulation using a vacuum pump.

- (1) Unscrew and remove the caps from the 2-way and 3-way valves.
- (2) Unscrew and remove the cap from the service port.
- (3) Connect the vacuum pump hose to the service port.
- (4) Operate the vacuum pump for 10 - 15 minutes until an absolute vacuum of 10 mm Hg has been reached.
- (5) With the vacuum pump still in operation, close the low - pressure knob on the vacuum pump coupling. Stop the vacuum pump.
- (6) Open the 2-way valve by 1/4 turn and then close it after 10 seconds. Check all the joints for leaks using liquid soap or an electronic leak device.
- (7) Turn the body of the 2-way and 3-way valves. Disconnect the vacuum pump hose.
- (8) Replace and tighten all the caps on the valves.

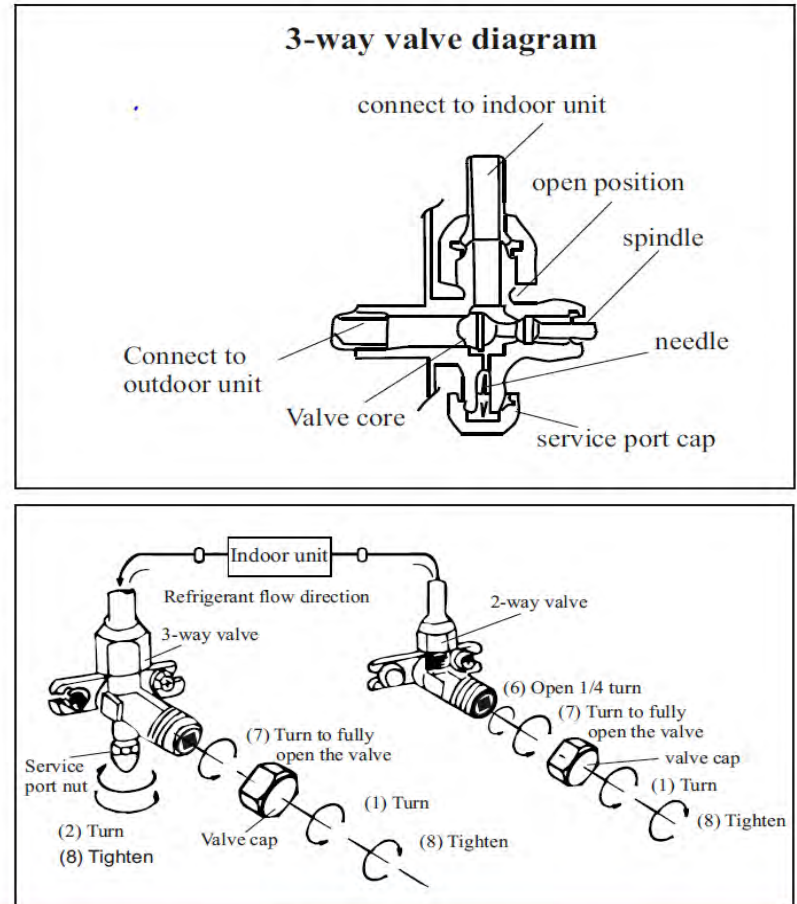

***Note: Vacuum line for 10 to 15 minutes, or to 30 microns.**



STEP 21 - Electrical Connection

Remove condenser electrical cover.



STEP 22

Plug Quick-Connect terminal from Indoor Unit into the Quick-Connect terminal from the Outdoor Unit.

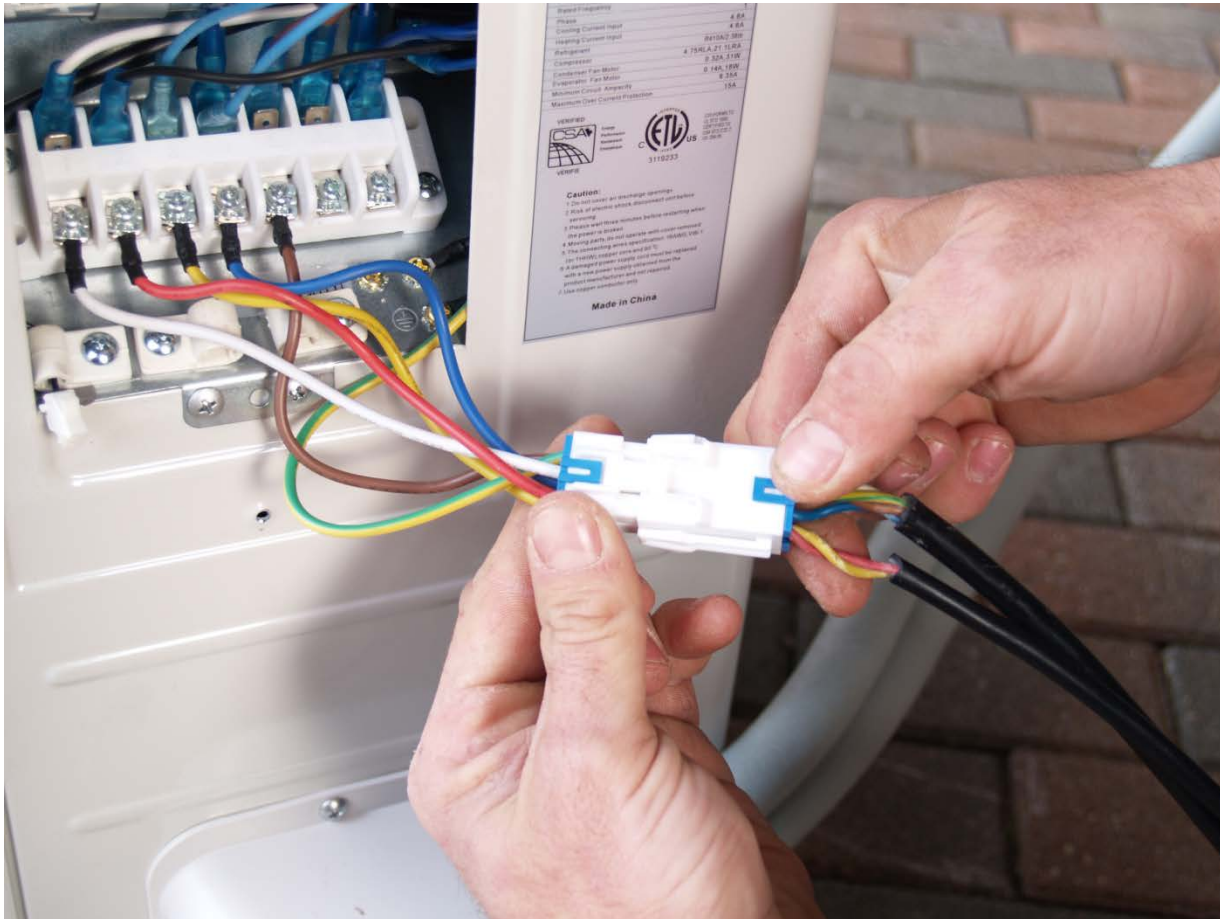

STEP 23

Connect ground to metal plate.

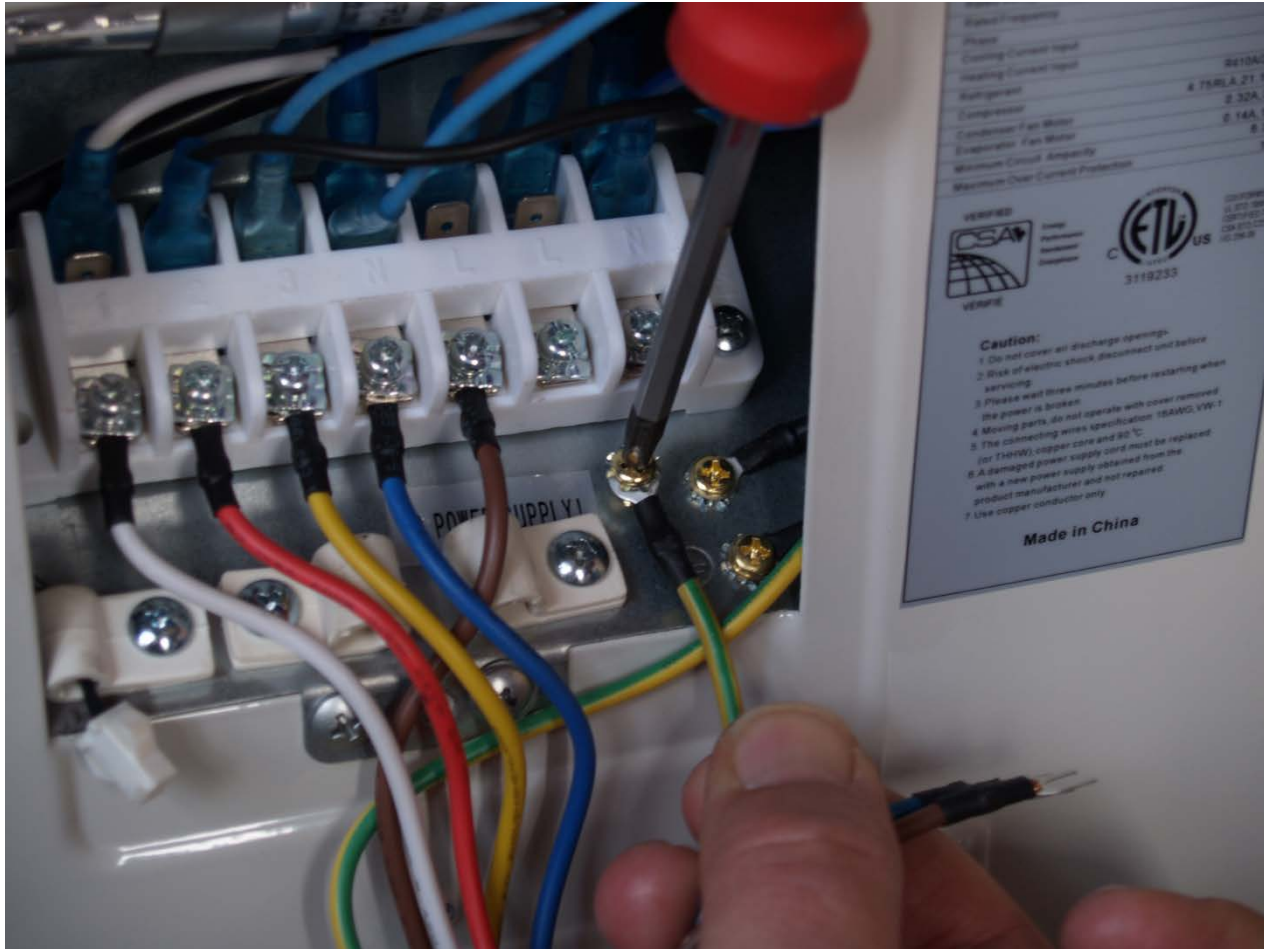

STEP 24

Connect line from service box to compressor.

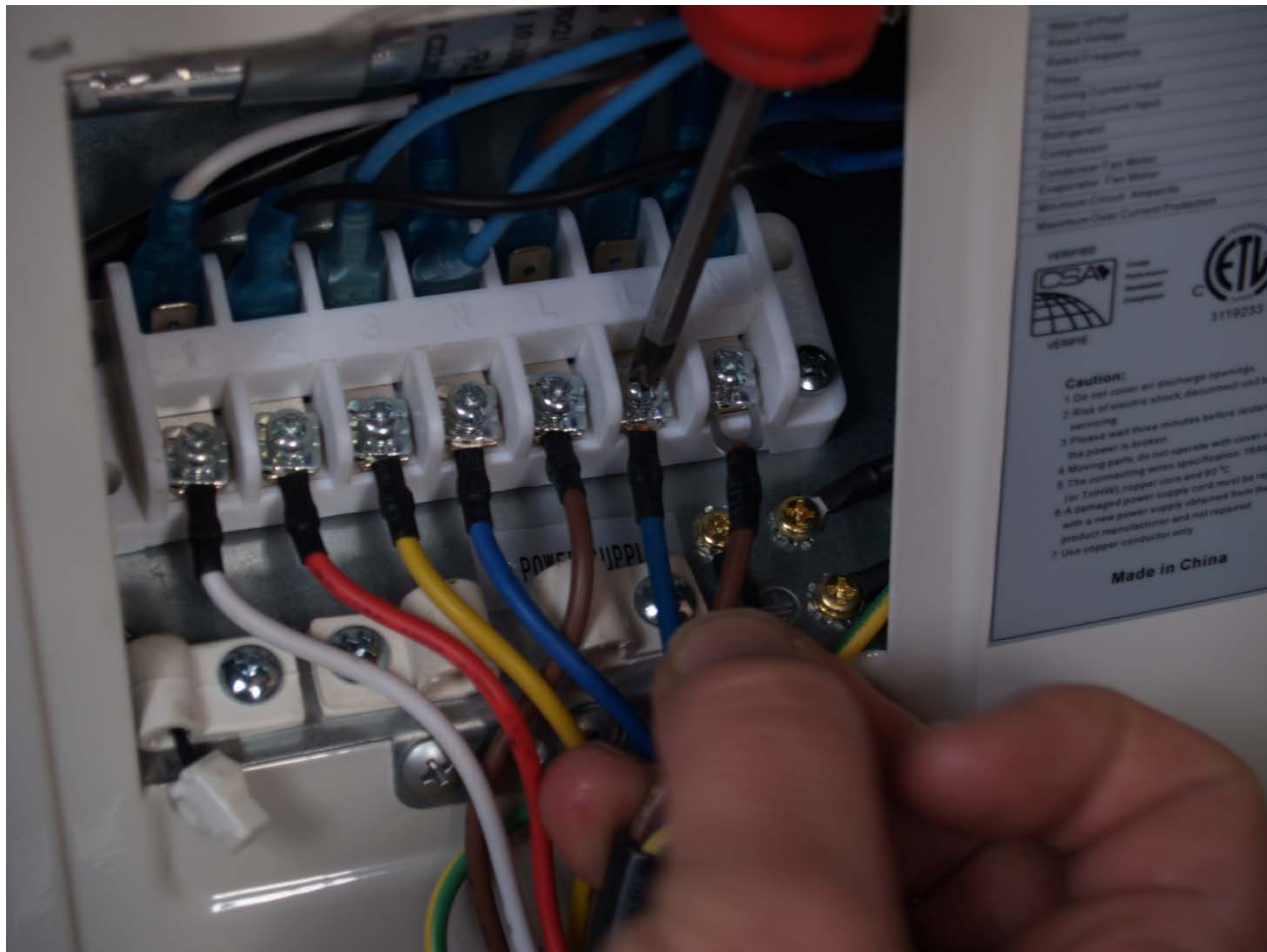

STEP 25

Re-install the electrical cover.



STEP 26 – Purge Excess Air

Open high side valve ¼ turn counter clockwise.



STEP 27

Remove service valve cap.



STEP 28

Press schrader (Service) valve for 3 seconds.



STEP 29

Open liquid valve completely counter clockwise.

*Note: Valve must be fully open.



STEP 30

Open suction valve completely counter clockwise.

*Note: Valve must be fully open.



STEP 31

Check for leaks at all joint connections.



STEP 32

Wrap remaining refrigerant line with UV insulation tape.



FINAL STEP

Test the system.

- A. Turn the breaker on.
- B. Using the remote control, turn the Indoor Unit on.
- C. Check all system functions for proper operation.