

# Little Giant<sup>®</sup> Ladder Systems

## Classic

### USER INSTRUCTIONS

Thank you for purchasing the Little Giant Classic—the original multi-use ladder. When used correctly, the Little Giant Classic is the strongest, safest, most versatile ladder in the world. Little Giant Ladder Systems subjects each ladder to comprehensive tests for safety in design and construction, so you can trust it in all the work you do. In addition, the Classic meets or exceeds stringent OSHA and ANSI safety standards.

Please don't ignore the instructions! Make the most of your ladder system by learning how to use it safely. If you have any questions about how to operate your Little Giant Classic, please call us. We value our customers, and we're happy to help.

Customer Service: **800-453-1192**

**Little Giant Ladder Systems**  
**1198 N. Spring Creek Place**  
**Springville, UT 84663**  
[www.littlegiantladders.com](http://www.littlegiantladders.com)

The Classic is made up of three major components: one inner ladder assembly and two outer ladder assemblies that telescope over the inner. The inner and outer assemblies work together with the Triple-Locking hinge and the lock tabs to adjust the ladder into different lengths and positions, including an A-frame stepladder, an extension ladder, a staircase ladder, a 90-degree ladder, and trestles for scaffolding. Each rung has slip-resistant treads, and each leg is equipped with rubber feet for improved traction.

**Inner and Outer Assemblies.** When the ladder is in its storage position, the inner assembly remains inside the outer assembly. To raise the ladder's height, simply telescope the inner assembly upward and then lock it in place at the desired height using the lock tabs on each side of the ladder. To lower the height again, telescope the inner assembly back into the outer.

**Triple-Locking Hinge.** The Triple-Locking hinge is located at the top of the ladder. The hinge unlocks so you can adjust the ladder into different working positions. Understand how the Triple-Locking hinge works by following the instructions listed on this manual to adjust the ladder from its storage position and into a working position.

**Work Platform** (optional). The versatile Work Platform fits on the rungs of any Little Giant multi-use ladder and is rated to hold up to 300 lbs. Use it as a tray for a paint bucket or tools, or use it as a sturdy, comfortable standing platform. Now you can stand on your ladder for extended periods without sore feet and bruised shins, and you can work with both hands in any direction. (Do not stand on the Platform above the third rung from the top.) The Work Platform also serves as a stabilizing spreader bracket for your Little Giant's trestle-and-plank scaffolding system.



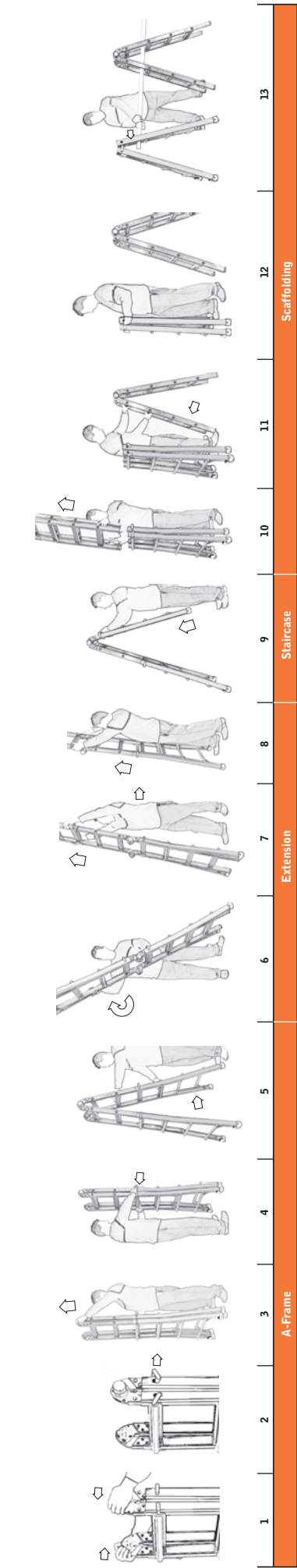

# Classic

Thank you for purchasing the Little Giant Classic multi-use ladder. The Classic is the original multi-use ladder, constructed to exacting standards with the highest quality materials. Here is a quick reference guide to help you get the most out of your ladder.

## A-Frame

1. Unlock the Triple-Locking hinge. (see Figure 1)
2. Unlock the lock tabs. (see Figure 2)
3. Raise the inner ladder section to the desired height. (see Figure 3)
4. Align and engage the lock tabs in the rung holes. (see Figure 4)
5. Pull the two halves of the ladder apart until the hinges lock in the A-frame position. (see Figure 5)

## Extension

1. Unlock the Triple-Locking hinge. (see Figure 1)
2. Open the ladder to the extension position. (Figure 6)
3. Unlock the lock tabs. (see Figure 2)
4. Raise the upper half to the desired height. (see Figure 7)
5. Align and engage the lock tabs in the rung holes. (see Figure 4)
6. If necessary, raise the lower half for additional height. (see Figure 8)

Need Help? Visit [www.littlegiantladders.com](http://www.littlegiantladders.com) or call Customer Care at 800-453-1192.

## Staircase / 90-Degree

1. Unlock the Triple-Locking hinges. (see Figure 1)
2. Unlock the lock tabs. (see Figure 2)
3. Raise the inner ladder section to your desired height. (see Figure 3)
4. Align and engage the lock tabs with the rung holes. (see Figure 4)
5. Pull the two halves of the ladder apart until the hinges lock in the A-frame position. (see Figure 5)
6. Adjust one side of the ladder to the length needed to fit safely in your staircase. (see Figure 9)
7. The 90-degree position is intended to bring the user of the ladder closer to a work surface, without reaching to the side. The 90-degree position (where one side is 1 foot shorter than the other and the ladder is placed on a level flat surface) must only be used when back of the ladder is against a wall. (see Figure 14)

## Scaffolding

1. Unlock the Triple-Locking hinges. (see Figure 1)
2. Unlock the lock tabs. (see Figure 2)
3. Pull the inner ladder assembly completely out of the outer ladder sections. (see Figure 10)
4. Open the inner ladder assembly to form the first trestle. (see Figure 11)
5. Turn one outer assembly around so both are facing the same direction (see Figure 12) and lock them together using the lock tabs on nearest outer assembly.
6. For extra stability, insert the Little Giant Work Platform in the second rung of the outer assembly and push it down to lock it in place and to secure the trestle. (see Figure 13)
7. Place an appropriate scaffolding plank at 3 feet or lower for scaffolding. (see Figure 13)

## Work Platform

If you purchased a Work Platform for your Little Giant Classic, you can use it as an additional tool tray or standing platform.

1. Place the Work Platform's hooks on the rung below your desired platform height. (see Figure 15)
2. Place the Work Platform at the desired platform height. (see Figure 16)
3. Push Work Platform forward; step directly on the platform. (see Figure 17)
4. Climb to the rung above the platform and push the platform into position with your toe. (see Figure 18)
5. Ensure the platform is secure and step onto the Work Platform. (see Figure 19)
6. When finished, step to the rung above and push the platform forward with the toe of your shoe and carefully step down through the platform. (see Figures 20 and 21)
7. To store the Work Platform, open the ladder slightly and hang the platform inside the ladder on the second rung from the bottom. (see Figures 22 and 23).

# Little Giant Ladder Systems

©2019 Little Giant Ladder Systems 52009-21.0

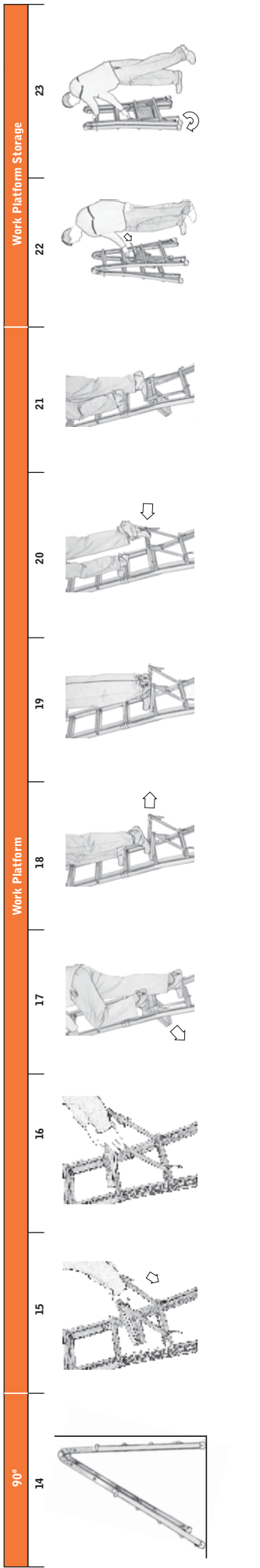

# GENERAL OPERATING SAFETY TIPS

## Classic Operating Safety Tips

1. Little Giant Ladder Systems assumes no liability for damage or injury that may result from failing to follow all instructions correctly.
2. The Classic has an ANSI duty rating of 300 pounds. For your safety, do not exceed the weight limit. Follow other safety tips listed on your ladder.
3. Read all labels on the ladder before use.
4. Always hold the ladder with both hands on the vertical upper rails or hinges while telescoping the inner ladder up or down.
5. Make sure each of the four lock tabs is fully engaged into the rung holes before climbing on the ladder. Failure to do so may result in injury.
6. Hinge lock must be fully engaged before using. Failure to do so may result in injury.
7. Do not open the lock tabs without first securing the inner ladder assembly to prevent it from sliding down rapidly.
8. Use caution when using the ladder around electricity. Ensure that the ladder does not come in contact with electrical circuits or currents.
9. Keep clothing and body parts out of working, moving mechanisms, including the Triple-Locking hinge and the lock tabs to avoid pinching.
10. Do not stand above the third rung from top.
11. Keep all ladder rungs, ladder feet, work platforms, and other standing and gripping surfaces clean and free from foreign materials.
12. Make certain the Work Platform is secure before standing on it.
13. Do not force the hinges in or out using any tools. You may cause permanent damage to the hinge mechanism.
14. If there is pressure on the hinge lock pins, they may not open properly. Relieve the pressure by moving one half of the ladder back and forth until the hinge locks move with minimal force.
15. Use the proper angle for the extension ladder position. The distance from the base of the ladder to the bottom of the support wall should be one quarter the working height of the extension ladder, with a minimum of three horizontal feet.
16. Do not allow the full weight of the ladder to fall on the hinges as the ladder folds from the extension to the A-frame position (see Figure 4).
17. For your safety, the rungs should always be level from front to back and from side to side.
18. Do not use outer or inner sections of the ladder as a separate stepladder.

## General Ladder Safety Tips

1. Select the correct ladder for your job—a ladder that is both rated for your weight and designed for the appropriate height and type of work you're doing. For example, if you're cleaning out gutters, you may need a tall ladder, not a stepladder.
2. Do a basic safety check before you get on any ladder. Look it over and make sure that rivets and welds are tight and in good condition, that rails are in place, and that the ladder doesn't wobble unsafely. Check the feet of the ladder to make sure there's no build up of dirt, oil, or other material that would create an uneven surface.
3. Face forward and climb one rung at a time while going up or down a ladder.
4. Don't stand on either of the top two rungs of any kind of ladder.
5. If there are multiple ladders set up against a building, don't step from one ladder to the next. Climb down the ladder you're on and before going up the next.
6. When you're on a ladder, don't lean or reach far to one side; a good rule of thumb is to always keep your belt buckle between the side rails. It's better to be safe and come down from the ladder and move it closer to your work area than to reach too far and cause the ladder to fall.

## Register Your Warranty

The Little Giant Classic comes with a limited lifetime warranty against manufacturer defects. For detailed information on the Little Giant Classic Warranty, please visit [www.LittleGiantLadders.com](http://www.LittleGiantLadders.com).

It only takes a moment to protect your investment for a long time, so don't forget to register your Classic warranty through one of three methods:

1. Go online at [www.LittleGiantLadders.com](http://www.LittleGiantLadders.com).
2. Call Little Giant Ladder Systems at 800-453-1192.
3. Return the Little Giant Ladder Systems warranty card by mail.