

# CF75 Country Garden Swing

Please check contents **before assembly**. If any items are missing or damaged, **do not take the unit back to the store**. Call 1-800-427-5136 for customer service, we will save you time by correcting any problems directly for you.

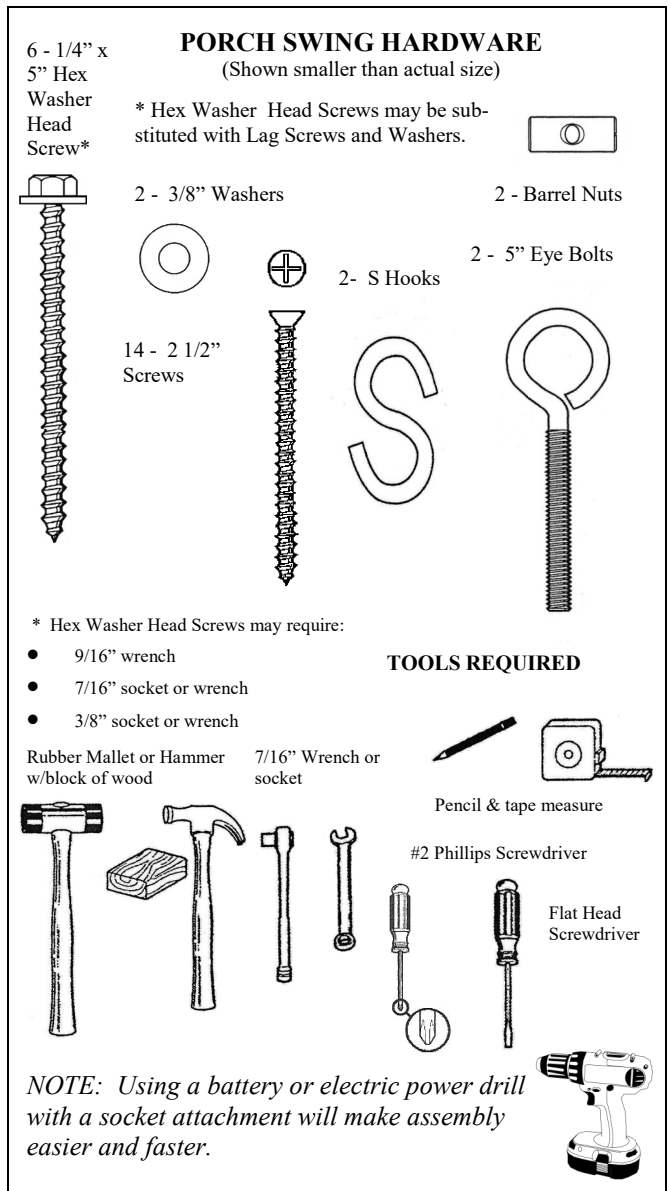
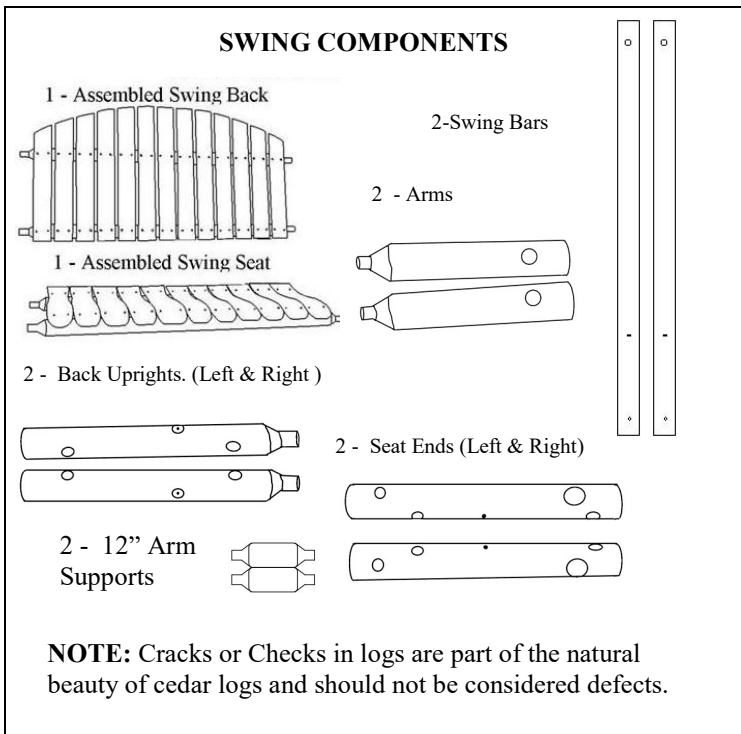

**NOTE:** Read all instructions before starting.

#### Helpful Tips:

- To start lag screws, hammer into wood about 1/2" then use wrench or socket to tighten.
- Use a rubber mallet (or block of wood between the hammer and the unit) to drive doweled ends into holes as far as possible.
- Use a good quality penetrating oil or wood deck sealer with a UV inhibitor and an anti-fungal. (Make sure product is intended for outdoor use.)
- If staining or finishing before assembling, tape off all dowel ends. (Finishes will cause the dowels to swell, making assembly difficult.)
- If you have hardware left over after completing your unit, it most likely has been assembled incorrectly, and may not be safe to use. Please call Customer Service at 800-427-5136 for assistance.
- **Check all nuts and bolts for tightness before and during each usage season.**

**Step 1** Assemble right and left, end swing assemblies. Insert the 12" arm support into the hole of the arm. Insert the doweled end of the arm into the angled hole of the back upright. See Figure 1. Repeat process for opposite side.

**Step 2** Install seat ends. The larger hole will attach to the 12" arm support, and the angled hole will be toward the back. The other two holes from the seat end will face the same direction as the two holes of the back upright. See Figure 2. Insert 5" lag screw through the pre-drilled holes on the back of the uprights and into the doweled end of the arm. Repeat on other end assembly.

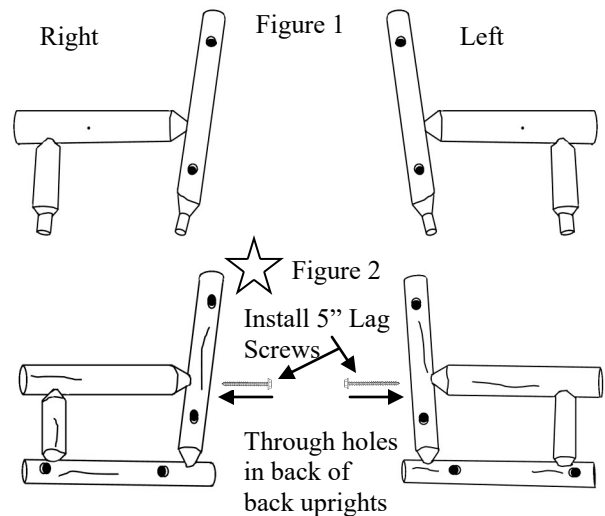
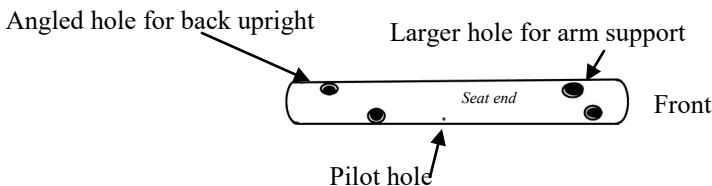

Step 3-5 Insert the assembled seat into the holes of the seat end of the assembled side. See Figure 3. Next insert the assembled back into the holes of the upright. See Figure 4. Now place the remaining end assembly onto the doweled ends of the assembled seat and back. See Figure 5. Drive all doweled ends into the holes as far as they will go.  
**NOTE:** Do Not move the assembled swing until you have finished Step 6.

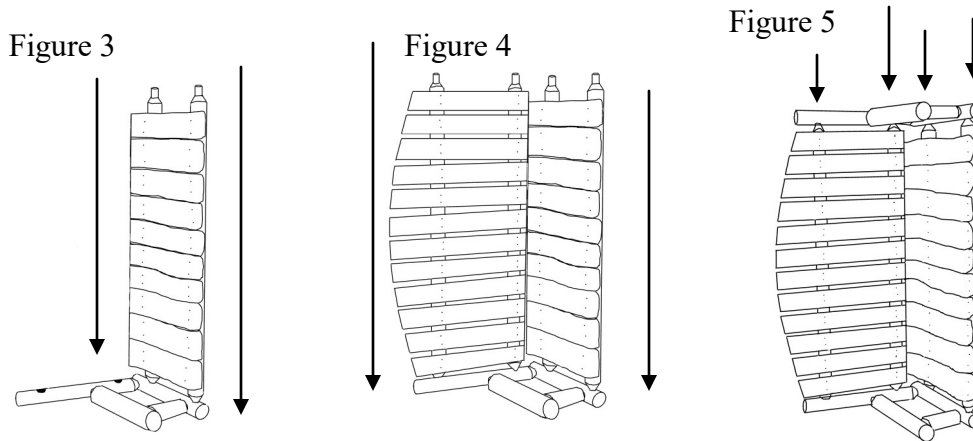

Step 6 Secure all doweled joints in place with screws perpendicular to the doweled end as shown at right in Figures 6 and 7. Repeat process on other end assembly. **NOTE:** Be sure to position screws so that it will go through the dowel ends and into the wood behind it.

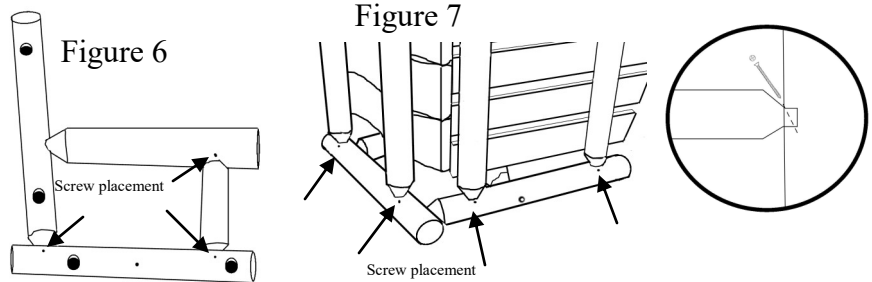

Step 7 Place barrel nut into horizontally drilled hole in end of swing bar. Position barrel nut with regular screwdriver and screw in 5" eyebolt with 3/8" washer as shown. **TIGHTEN DOWN SECURELY!** Repeat on other swing bar. See Figure 8.

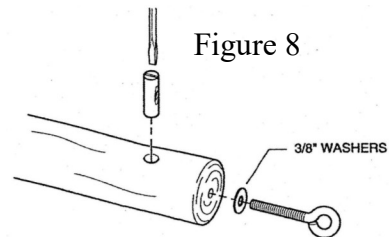

Step 8 Place the 5" Hex Washer Head Lag Screws through the predrilled holes of the swing bars. With a hammer, tap the lag screw into the predrilled hole of the seat end about 1/2", repeat process with lag screw and predrilled hole of the arm. (This is our recommended pitch of the seat. You may change the pitch by altering the location of the lag screws in the arm.) See Figure 9. It may be necessary to adjust arm if hole does not line up with lag screw of upright. (To adjust, back out screws of arm supports and tap arm up or down until hole lines up with lag screw.) Tighten down lag screws.

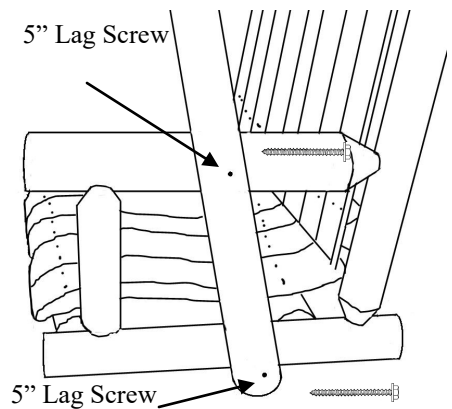

***If you have hardware left over, it most likely is assembled incorrectly, and may not be safe to use. Please call Customer Service at 800-427-5136 for assistance.***

Like  
**lakeland  
 mills**  
 on

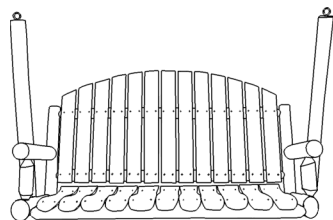

Figure 9