

Assembly Instructions

CM3803PC-2PK

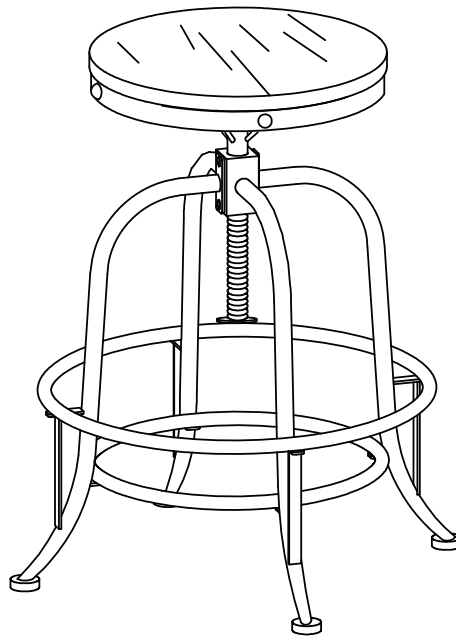

ASSEMBLY RATING

The Assembly Rating is a 5-point system that shows the degree of effort needed in assembling a specific product (with 1 being easy and 5 being difficult). For some products, two persons are recommended.

EASY  DIFFICULT

Tools Required For Assembly:

Allen Wrench

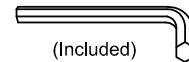

2 PERSONS RECOMMENDED

ASSEMBLY & CARE ADVICE

FOR YOUR FURNITURE TO LAST, CORRECT ASSEMBLY AND PROPER MAINTENANCE ARE NECESSARY. PLEASE FOLLOW THE INFORMATION PROVIDED BELOW TO FULLY ENJOY YOUR FURNITURE.

BASIC ASSEMBLY TECHNIQUES

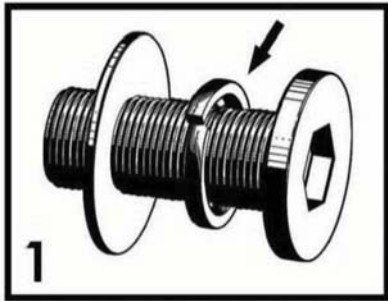

1 When lock or spring washer is used in an assembly, please make sure the lock or spring washer is placed between the larger flat washer and the head of the screw or bolt.

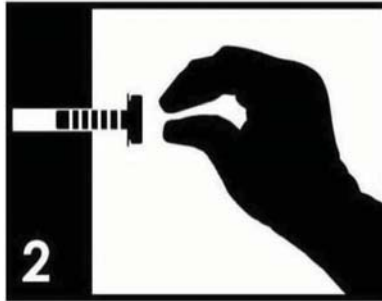

2 Position each part correctly and insert screws or bolts into their respective holes by hand tighten or using the proper hand tool. Only tighten when step is completed or when instructed to do so.

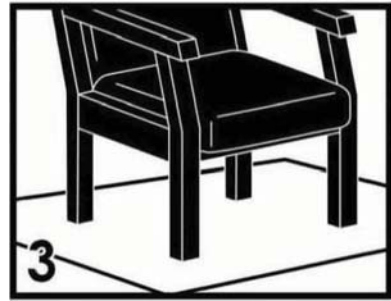

3 Use cardboard or carpet area when assembling furniture to prevent scratches. Make sure the furniture rests on a flat and level surface with each leg evenly touching the floor.

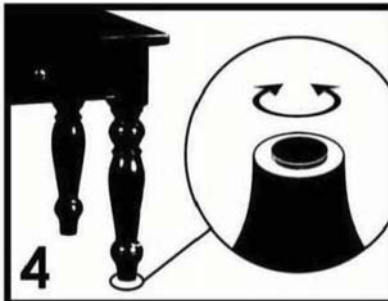

4 Some furniture comes with height adjustment knobs underneath each leg. To lower or to raise each leg, you need to turn clockwise or counterclockwise, respectively.

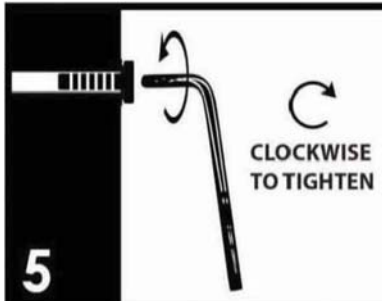

5 Make sure all parts are properly aligned, then use the appropriate hand tool to completely tighten the bolts or screws. Do not use power tools and do not overtighten.

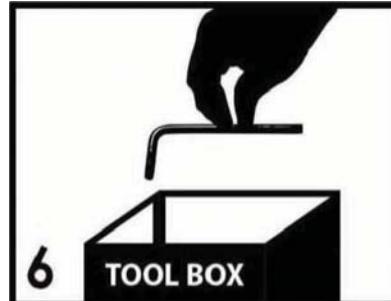

6 Save the instructions and store the Allen wrench or any supplied tool for later maintenance. After two weeks, check and tighten any loose hardware and repeat again every six months thereafter.

IT IS THE USER'S RESPONSIBILITY TO MAINTAIN THE FURNITURE. THE HARDWARE MAY LOOSEN OVER TIME AND MAY CAUSE THE FURNITURE TO BE WOBBLY AND UNABLE TO SUPPORT ITS INTENDED WEIGHT CAPACITY. THIS MAY LEAD TO COLLAPSE AND MAY CAUSE SERIOUS INJURY.

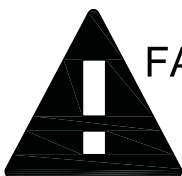







FAILURE TO FOLLOW THE GUIDELINES ABOVE MAY RESULT IN INJURY AND/OR PROPERTY DAMAGE.



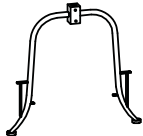

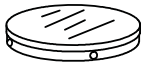

Before you begin, please read Page 2 of "Assembly and Care Advice".

And remember, do not tighten until each step is completed or instructed.

Parts List

-  #1 x 1pc x 2
Leg Frame
-  #2 x 2pcs x 2
Leg
-  #3 x 1pc x 2
Bottom Ring
-  #4 x 1pc x 2
Center Ring
-  #5 x 1pc x 2
Seat
-  #6 x 1pc x 2
Metal Plate and Pole

Hardware List

-  #A x 5pcs x 2
Bolt 1/4"X1/2"
-  #B x 12pcs x 2
Bolt 1/4"X5/8"
-  #C x 1pc x 2
Flat Washer Ø28mm
-  #D x 1pc x 2
Allen Wrench

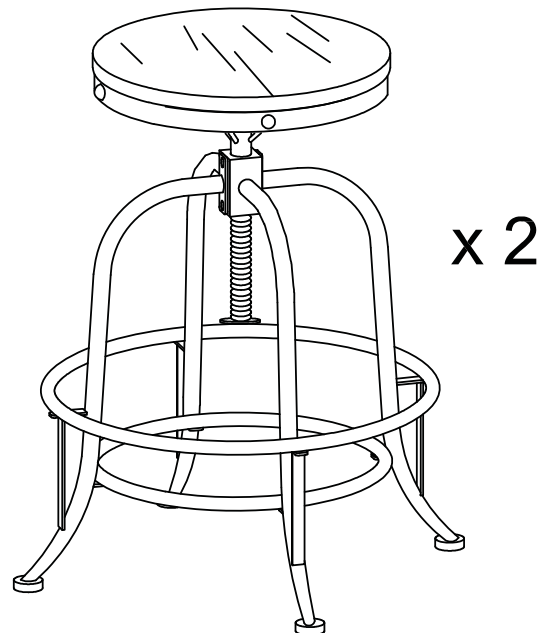



#1

#A x 4pcs

Align a leg (#2) to each side of the leg frame (#1), then insert 2 bolts (#A) into each end. Secure using the Allen wrench (#D).

#A



#A



#D



#1

#A



#A



#2

#2



#2

#B x 4pcs

Align the holes along the bottom ring (#3) to the holes along the legs, then insert a bolt (#B) into each hole and secure using the Allen wrench (#D).

#D

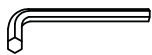

#B



#3

#2

#1



#3

Align the holes along the center ring (#4) to the holes along the outer part of the legs, then insert a bolt (#B) into each hole and secure using the Allen wrench (#D).

#B x 4pcs

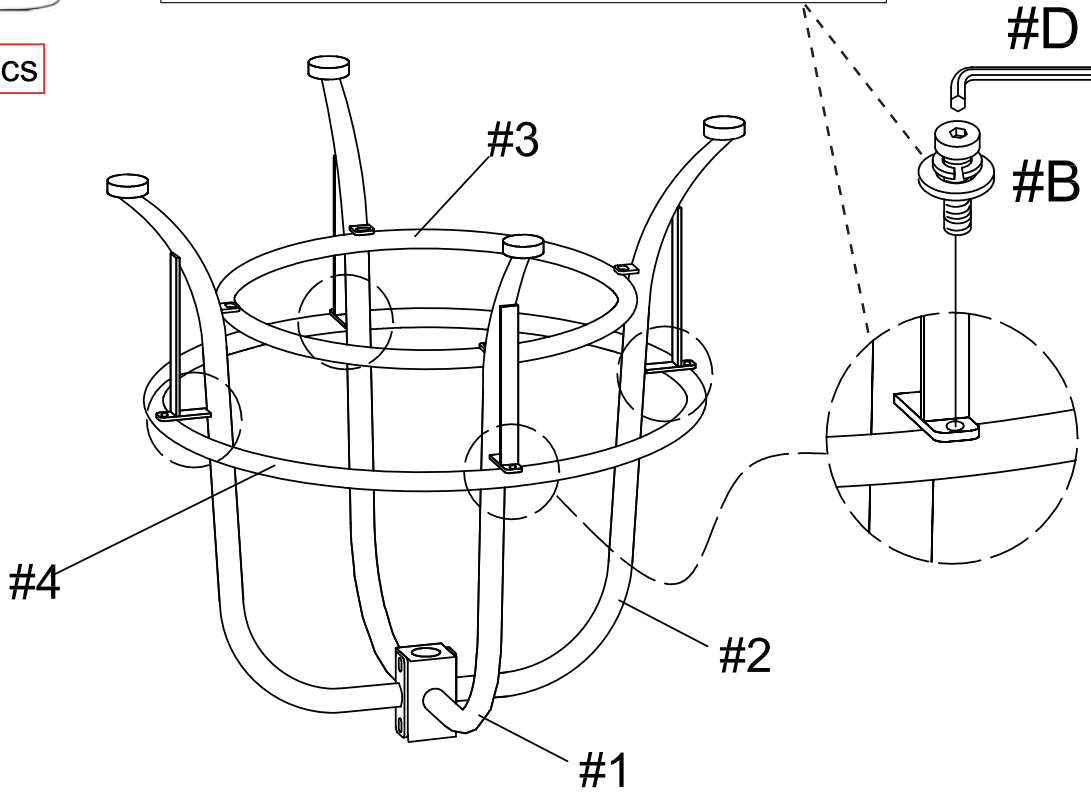

#4

1. Place the seat (#5) face down, then align the metal plate and pole (#6) to the holes along the bottom of the seat.

#B x 4pcs

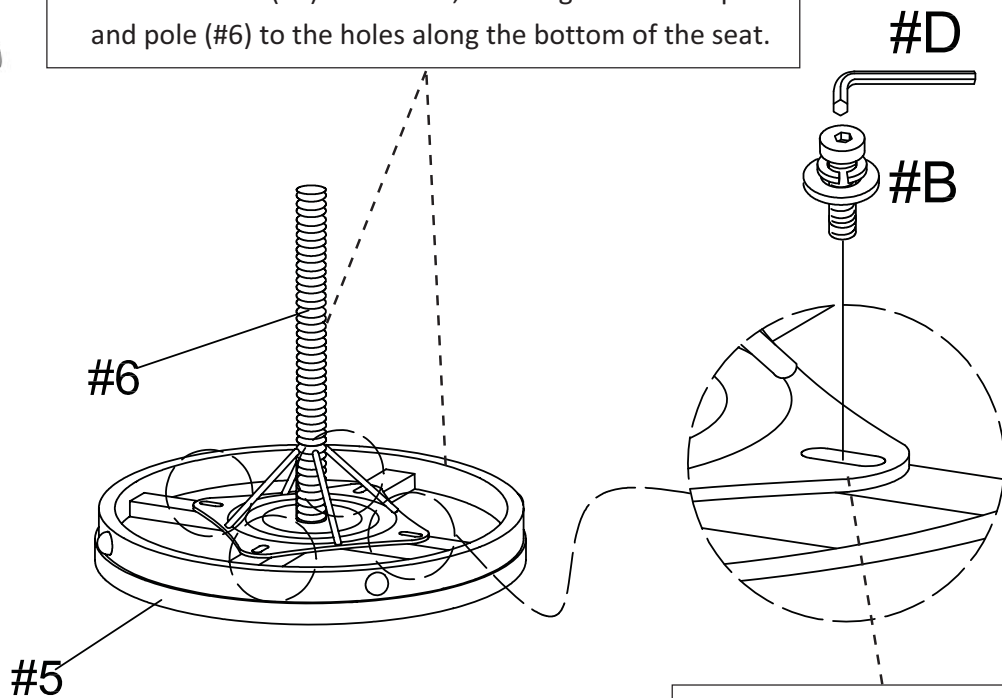

2. Insert a bolt (#B) into each hole and secure using the Allen wrench (#D).



#5

Place the leg frame upright, then insert the metal pole (#6) into the top center hole. Turn right to tighten.

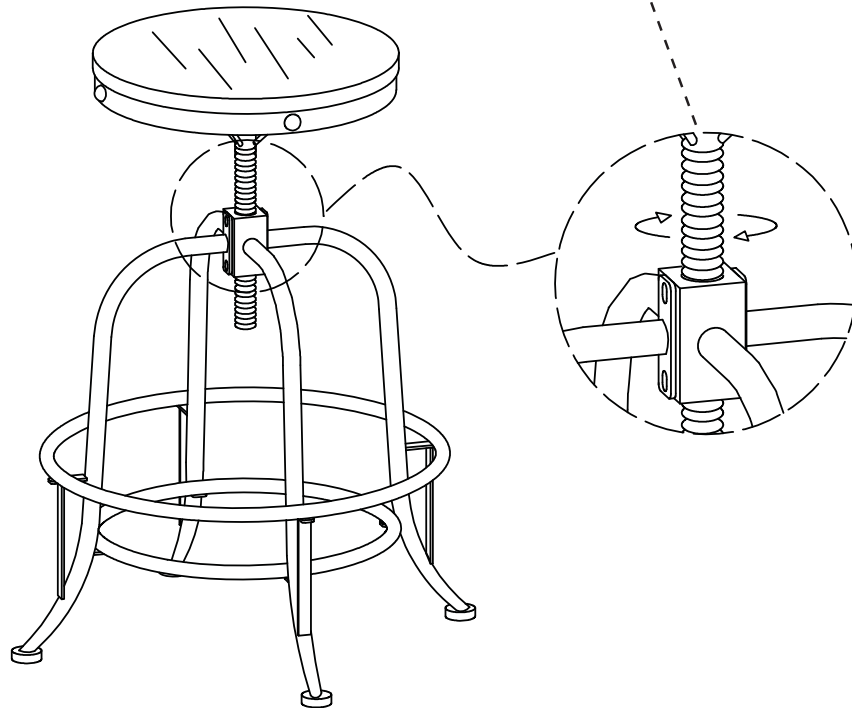

#6

#A x 1pc
#C x 1pc

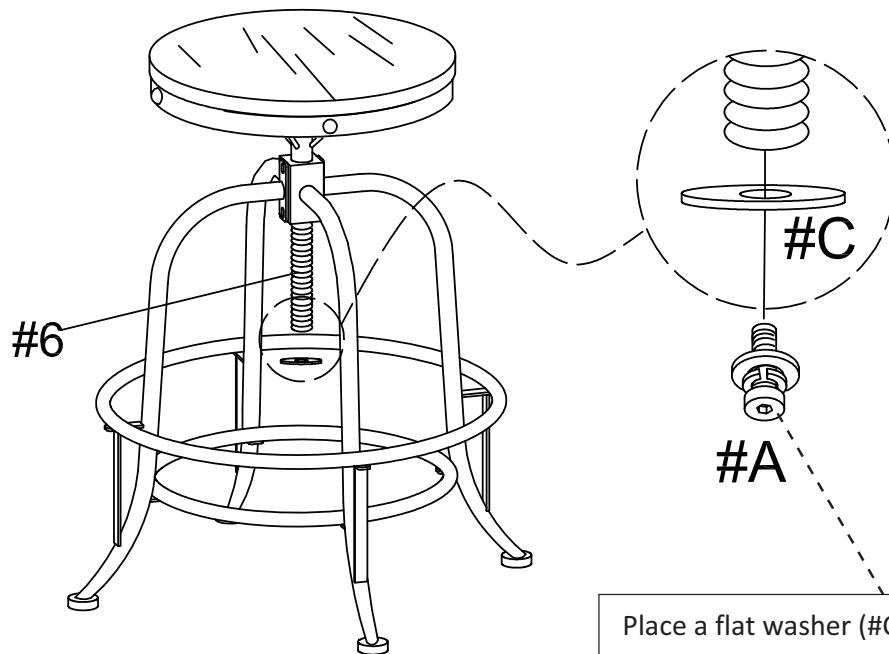

Place a flat washer (#C) onto the bolt (#A) then insert the bolt assembly into the hole at the end of the metal pole (#6). Secure using the Allen wrench.

ASSEMBLY IS COMPLETED