

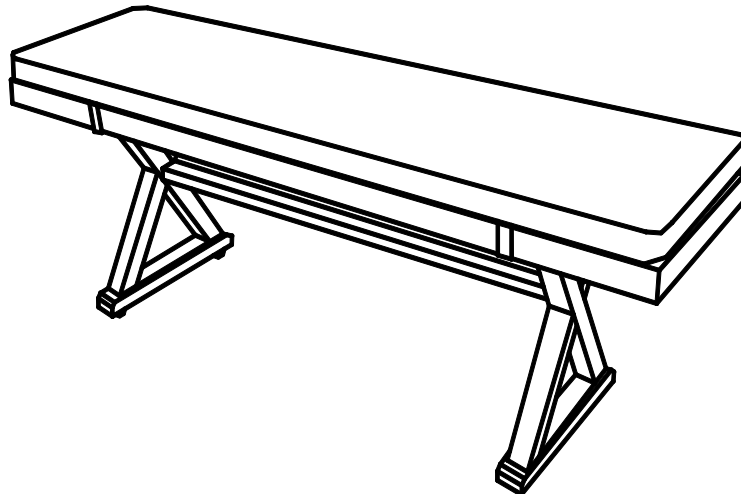

Item #1000 302 643/1000 131 573
Model #DY9127-BENCH/DY9127-BEN-R

USE AND CARE GUIDE

WOODBURY BENCH



Questions, problems, missing parts? Before returning to the store,
call Hampton Bay Customer Service
8 a.m. - 7 p.m., EST, Monday-Friday
9 a.m. - 6 p.m., EST, Saturday

1-855-HD-HAMPTON

HAMPTONBAY.COM

THANK YOU

We appreciate the trust and confidence you have placed in Hampton Bay through the purchase of this bench. We strive to continually create quality products designed to enhance your home. Visit us online to see our full line of products available for your home improvement needs. Thank you for choosing Hampton Bay!

Table of Contents

Table of Contents.....	2	Pre-Assembly	3
Warranty.....	2	Planning Assembly	3
What is Covered.....	2	Hardware Included	3
What is Not Covered	2	Package Contents.....	4
		Assembly	5
		Care and Cleaning	6

Warranty

THIS IS A RESIDENTIAL WARRANTY ONLY AND THIS WARRANTY DOES NOT APPLY TO COMMERCIAL USE

5 YEAR FRAME LIMITED WARRANTY/2 YEAR FABRIC LIMITED WARRANTY

WHAT IS COVERED

We warrant the frame to be free of manufacturing defects to the original purchaser for five years and the fabric for two years.

WHAT IS NOT COVERED

It remains the customer's responsibility for freight and packaging charges to and from our service center.

This warranty does not cover commercial use, hardware, acts of nature, fire, freezing, and abusive use.

In addition, purchased parts are not covered under this warranty. We reserve the right to make substitutions with similar merchandise, if the model in question is no longer in production.

For a copy of our full limited warranty, please contact our customer service team below.

Contact the Customer Service Team at 1-855-HD-HAMPTON or visit www.hamptonbay.com.

Pre-Assembly

PLANNING ASSEMBLY

Please read this entire instruction manual prior to assembly. Identify all parts packed in the carton against the parts list. Remove all protective materials and place the parts on a non-abrasive surface to avoid scratching.



NOTE: More than one person may be required to complete the assembly of this product.

HARDWARE INCLUDED



NOTE: Tools not shown to actual size.

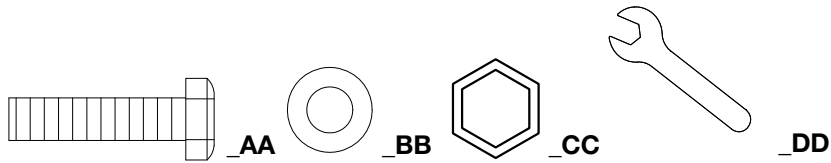

Part	Description	Quantity
AA	M6*25 Hex Bolt	10
BB	Washer	10
CC	Cap	10
DD	M6 Wrench	1

Pre-Assembly (Continued)

PACKAGE CONTENTS

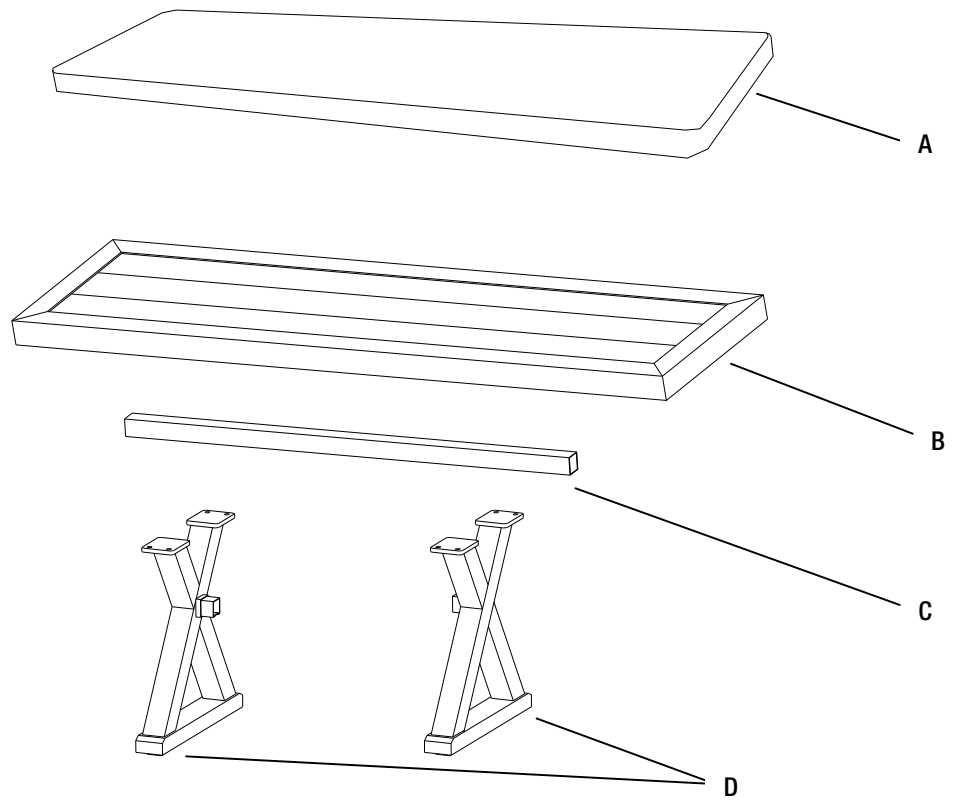

Part	Description	Quantity
A	Seat cushion	1
B	Bench top	1
C	Center connectors	1
D	Bench leg	2

Assembly

1 Attaching the bench legs

- Attach the connector (C) to the bench legs (D) using the M6 hex bolts (AA) and washers (BB). Tighten all bolts and cover the bolt heads with caps (CC).

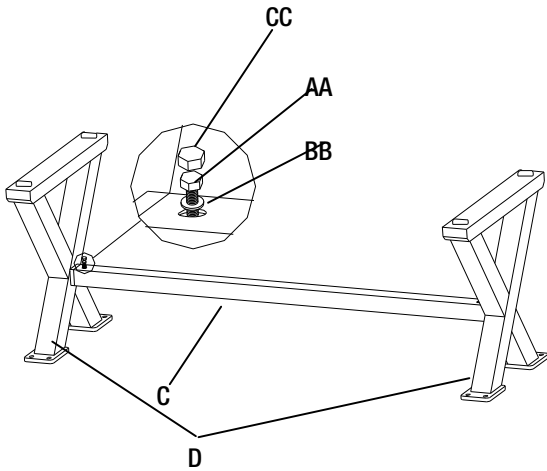

2 Attaching the bench top

- Place the bench top (B) on a soft, flat non-abrasive surface. Attach the bench legs (D) to the bench top (B) with the M6 hex bolts (AA) and washers (BB). Tighten all bolts and cover the bolt heads with caps (CC).

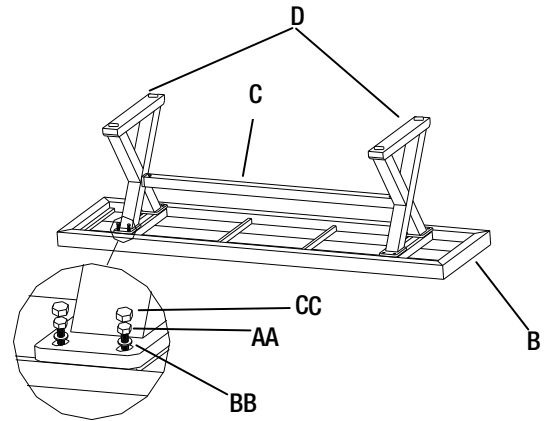

3 Attaching the seat cushion

- Turn the bench over and set it down on its legs.
- Place the seat cushion (A) onto the bench.

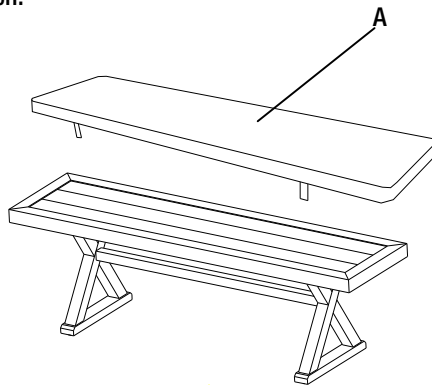

Care and Cleaning

- Do not allow water to build up in the frames. This will cause corrosion and possible freezing damage in cold climates.
- Use a mild soap and water for normal cleaning. Do not use janitorial or alcohol-based cleaners. Some cleaners may be marked as natural, but some ingredients may cause discoloration or have an adverse reaction to your finish.
- Rinse with clean water and dry with a soft, absorbent cloth towel.
- Treat frames with a liquid wax for maximum protection against UV rays and/or salty, damp air.



Questions, problems, missing parts? Before returning to the store,
call Hampton Bay Customer Service
8 a.m. - 7 p.m., EST, Monday-Friday
9 a.m. - 6 p.m., EST, Saturday

1-855-HD-HAMPTON

HAMPTONBAY.COM

Retain this manual for future use.