

**IMPORTANT WARRANTY INFORMATION PLEASE READ  
FILL OUT AND RETURN ENCLOSED WARRANTY CARD**

THIS WARRANTY COVERS:  
LEM Stainless Steel Hand Grinder #821  
THE WARRANTY IS EXTENDED TO THE ORIGINAL PURCHASER ONLY

**WARRANTY DURATION:** This product is warranted to the original purchaser for a period of one (1) year from the original purchase date. **EACH UNIT COMES WITH A WARRANTY CARD, WHICH MUST BE FILLED OUT COMPLETELY AND RETURNED IMMEDIATELY, WITH A COPY OF THE PURCHASING RECEIPT. FAILURE TO RETURN YOUR WARRANTY CARD WILL LIMIT WARRANTY TO 90 DAYS WITH PROOF OF PURCHASE.**

**WARRANTY COVERAGE:** This product is warranted against defective materials or workmanship. The warranty is void if the product has been damaged by accident, misuse, neglect, modification or improper service or repairs by unauthorized personnel. It is also void if damaged in shipment or by other causes not arising out of defects in the materials or workmanship. This warranty does not extend to any units which have been in violation of written instructions furnished. This warranty covers only the product and its specific parts, not food or other products processed in it.

**WARRANTY DISCLAIMERS:** This warranty is in lieu of all warranties expressed or implied, and no representative or person is authorized to assume any other liability in connection with the sale of our products. There shall be no claims for defects or failure of performance under any theory of sort, contract or commercial law including, but not limited to negligence, gross negligence, strict liability or breach of contract. The manufacturer declines all responsibility for damage to persons, things or animals arising from the failure to comply with the norms contained in this manual. The manufacturer reserves the right to make modifications at anytime to the models while maintaining the main characteristics described herein. The manufacturer also declines all responsibility for any errors in compiling this manual.

**WARRANTY PERFORMANCE:** During the above one year warranty period, a product with a defect will either be repaired or replaced after the product has been inspected by an LEM Service Technician. **LEM RESERVES THE RIGHT TO REFUSE WARRANTY PERFORMANCE OR PRODUCT EVALUATION UNLESS THE ORIGINAL SALES RECEIPT OR THE WARRANTY CARD IS ON FILE.** The repaired product will be in warranty for the balance of the one year warranty period. No charge will be made for such repair or replacement.

**IMPORTANT NOTICE:** If any parts are missing or defective, please contact our Customer Service Department for assistance at 877-536-7763 (M-F 8:30am to 4:30pm EST). **DO NOT RETURN TO THE STORE WHERE THE PRODUCT WAS PURCHASED.**

**LEM PRODUCTS MERCHANDISE RETURN POLICY WARRANTY SERVICE:** To obtain service under terms of this warranty, please contact us at 877-536-7763 to obtain authorization prior to returning the merchandise. No merchandise will be accepted without prior authorization. Please return the product prepaid in the original packaging if possible, enclose a copy of your receipt, (keep a copy of your proof-of-purchase for your records) and include a written explanation of the issue. Ship to LEM Products, 4440 Muhlhauser Road, Suite 300, West Chester, OH 45011. LEM Products is not responsible for damage incurred in shipping, make certain to pack product properly. Return shipping charges are the responsibility of the purchaser. Packages returned to LEM should be insured for the value of the product to cover any damages that may occur during shipping.

Revised November 20, 2015

THE LEADER IN GAME PROCESSING



# STAINLESS STEEL HAND GRINDER

## USE & MAINTENANCE

821



**1 YEAR  
WARRANTY**

## ⚠ GENERAL WARNINGS AND SAFETY INFORMATION ⚠

### IT IS IMPORTANT TO READ AND UNDERSTAND ALL OF THE INSTRUCTIONS AND SAFEGUARDS PRIOR TO USE

1. Always ensure that the appliance is properly assembled and safely set up before use.
2. **CAUTION:** This appliance is not recommended for use near or by children or persons with certain disabilities. Set up and store the appliance out of reach of children. When not in use, store device in a secure and dry place out of reach of children.
3. The appliance is designed for domestic use and not for commercial purposes.
4. **DO NOT** use the appliance on bones, deep frozen food, hard items or non-food items.
5. Use the appliance with the supplied accessories only. **WARNING:** The use of attachments not recommended or sold by the manufacturer may cause injury, damage to personal property, and may void your warranty.
6. **WARNING:** Do not use while under the influence of alcohol or drugs (prescription or non-prescription) as these may impair user's ability to properly assemble or safely operate the appliance.
7. The manufacturer declines any responsibility in the case of improper use of this product. Improper use of this product voids the warranty.
8. **DO NOT** put your fingers into the mouth of the grinder while grinding. Instead, use an appropriate tool to push the meat into the grinder.
9. Thoroughly hand-wash all parts in warm soapy water prior to use. **DO NOT SOAK. NOT DISHWASHER SAFE** (discoloration may occur).
10. Tie back loose hair and clothing. Remove neckties, rings, watches, bracelets or other jewelry before operating.
11. Use on a level, stable surface to prevent tipping. Never move the appliance while in use.
12. **WARNING:** Knives are **SHARP!** To avoid injury, use extreme caution when handling.

## 13. SAVE THESE INSTRUCTIONS

## BEFORE USE

Hand wash all parts of the grinder in hot soapy water to remove the protective oil coating. Rinse with hot water and hand dry. **DO NOT PLACE UNIT IN DISHWASHER.**

## PARTS LIST

PART #	DESCRIPTION
1	RETAINING RING
2	KNIFE
3	AUGER STUD
4	AUGER
5	GRINDER BODY
6	CLAMP SCREW
7	HANDLE
8	HANDLE THUMB SCREW
9	3/16" PLATE FINE
10	3/8" PLATE COARSE
11	STUFFING TUBES
12	STUFFING TUBE FLANGE
13	STUFFING STAR
14	AUGER BUSHING (not shown)
15	RUBBER PADS (not shown)

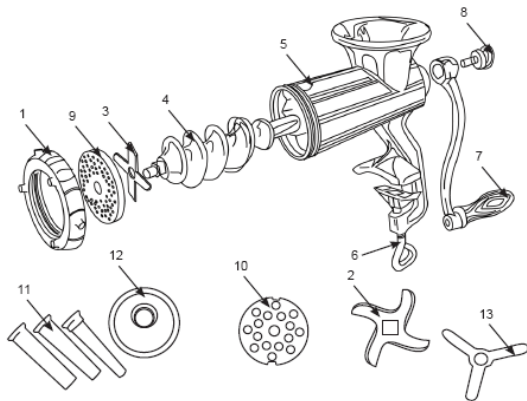

## ASSEMBLY

1. Bolt the grinder body (#5), using the clamp screw (#6), to a sturdy surface, which can be easily cleaned. Slide the auger (#4) in the grinder body. Attach the handle (#7) to the body using handle thumb screw (#8). Put the knife (#2) on the square portion of the auger stud (#3), making sure the sharp edges of the knife are facing out. Place the grinder plate (#9 or #10) on the pin portion of the auger stud. Make sure the notch in the plate is aligned with the locator pin on the grinder body. Hand tighten the retaining ring (#1) on the grinder body. Unit is ready for grinding.
2. Over-tightening the retaining ring will cause excessive wear on the knife and plate. Under tightening will cause the meat to be mashed instead of cut. If mashing occurs, disassemble the grinder, clean out the meat from the grinder and plate, reassemble the grinder and tighten the retaining ring a little tighter than it was originally.
3. After using the grinder, disassemble and hand wash in hot soapy water. Rinse with hot water and hand dry. **DO NOT PLACE UNIT IN DISHWASHER.** After drying, spray the grinder body, auger, knife and plates with a food grade silicon spray. This will prevent oxidation; keep the unit in good operation condition for many years of dependable service. LEM Products recommends that you use our Silicon Spray; it is USDA approved and complies with FDA regulations.
4. When making burger from wild game, add a minimum of 10% pork fat to the meat. This will give the burger moisture, but not make it fatty. If pork fat is not available, use beef fat. Never use beef suet. Suet is too hard. The burger will be cooked before the suet melts causing little suet particles to remain in the burger.
5. When making sausage, add at least 20% fat with the meat and grind it like burger. Mix the seasoning with the meat after the first grind and then grind the mixture a second time. For a coarser grind, grind the meat through the 3/16" plate one time. Then mix the seasoning with the meat. This works well for those who like coarse sausage. Also, LEM Products recommends you use our Soy Protein when making sausage. It is available in a 1 lb. package, which is enough for 50 lbs. of meat. Use 2 teaspoons of Soy Protein for each pound of meat. Soy Protein helps to retain moisture and prevent shrinking during smoking or cooking. It is very high in protein, making it an excellent binder, it also gives the finished sausage a smooth, moist consistency. Soy Protein has no taste. It contains no cholesterol and is fat free because it is derived from a vegetable source.
6. To stuff sausage casings, follow the directions provided with the stuffing tubes.

## CASINGS

1. LEM Products carries natural sheep, hog, and beef casings. Fresh casings produce a juicy, tender sausage. You'll hear a distinctive 'pop' when you bite into a sausage stuffed in a natural casing. To store unused natural casings, cover the casings with salt, place them in a zip lock bag and refrigerate. The casings will keep for an indefinite length of time. Natural casing produce 4-5 links per pound. Salted casings have a very long shelf life. If not refrigerated, the salted casings quickly give off a strong odor, even though they are not spoiled. Put them back under refrigeration and for the most part the odor disappears. To use natural casings: rinse in warm water several times, flush the inside, and then soak in warm water for 1/2 to 1 hour until they become soft and pliable.
2. When putting the casing on a stuffing tube, place it loosely on the tube. If it does not go on easily, the tube is too large. Forcing the casing onto a tube that is too large will cause breakage and it may not come off the tube correctly. Sausage meat should be stuffed as tightly as possible into the casing.
3. Collagen casings are uniform in size for easier stuffing. They can be used for fresh or smoked sausage. The smoked collagen casings are stronger than the fresh collagen casings so they can be hung in a smoker and not break. **DO NOT** soak collagen casings before stuffing.
4. Synthetic/Fibrous Casings can be used for summer sausage, hard salami, bologna, and many other sausages. They should be soaked in warm water for 20 – 30 minutes before stuffing.
5. Large synthetic casings should be stuffed one section at a time. Hold the casing firmly on the tube. Pack the meat tightly into the casing to prevent air pockets. After stuffing the casing, grab the untied end with one hand and the tied end with the other hand. Twist the untied end of the stuffed casing closed until the log becomes very firm. This next step may take 2 people. One person can hold the twisted filled casing and the other person can tie the open end closed. You can also use hog rings to close the open end of the casing. Hog rings and pliers are available at LEM Products. Inspect the stuffed casings for air pockets. Lightly puncture as many air pockets as possible to avoid fat reservoirs from forming in the pockets while cooking.