

THE LEADER IN GAME PROCESSING



BIG BITE™

ELECTRIC MEAT GRINDER

USE & MAINTENANCE

1158



**1 YEAR
WARRANTY**



ATTENTION:

If any components of this unit are broken,
or if the unit does not operate properly,
please contact LEM Products at

1-877-536-7763

For more great products or a free catalog
log onto www.lemproducts.com

! CAUTION !

Cuts, injuries and/or fire may result from non-compliance with all operating procedures described within this instruction manual.

LEM Products • West Chester, OH 45011 • 1-877-536-7763 • lemproducts.com

JUNE 2014

LEM Products • West Chester, OH 45011 • PH: 1-877-536-7763 • lemproducts.com



CAUTION



Before using the device for the first time please make sure to read carefully and thoroughly through these operating instructions and the safety advice. Familiarize yourself completely with the functions of the appliance.

GENERAL WARNINGS AND SAFETY INFORMATION

1. Always ensure that the appliance is properly assembled and safely set up before use.
2. **DO NOT** leave the appliance unattended if it can be switched on and operated.
3. **CAUTION:** This appliance is not recommended for use near or by children or persons with certain disabilities. Set up and store the appliance out of reach of children. When not in use, store device in a secure and dry place out of reach of children.
4. Store appliance in upright position to extend life of motor .
5. The appliance must be connected to a 120V AC electric supply only.
6. This appliance has a polarized plug (one blade is wider than the other). To reduce the risk of electric shock, this plug will fit in a polarized outlet one way. If the plug doesn't fit fully in the outlet, reverse the plug. If it still does not fit, contact a qualified electrician. **DO NOT** modify the plug in any way.
7. **DO NOT** operate with a damaged cord or plug, after the unit malfunctions, has been damaged in any way or if appliance has been immersed in water or other liquid. Return unit to LEM Products for assessment and repair.
8. Always unplug unit when not in use, when changing parts or cleaning.
9. Never unplug by pulling on the power cord, always pull directly on the plug itself.
10. **DO NOT** let cord hang over edge of table or counter, contact sharp edges or touch hot surfaces.
11. Indoor use only. To protect against the risk of electrical shock, never immerse the device in water and do not expose the device to rain or moisture. **WARNING:** In the event the device should fall into water, remove the plug from the wall socket before attempting to remove the unit from the water. If submergence occurs, have the appliance examined by an authorized technician before use.
12. To protect against the risk of electrical shock, **DO NOT** use the appliance if your hands are wet or if you are standing on a wet floor. **DO NOT** use the appliance if it is wet or moist. **DO NOT** operate this device with wet hands or bare feet. **DO NOT** operate near running water.
13. The appliance is designed exclusively for domestic use and not for commercial purposes.
14. **DO NOT** use the appliance to grind bones, deep frozen food, hard items or non-food items.
15. Use the appliance with the supplied accessories only. **WARNING:** The use of attachments not recommended or sold by the manufacturer may cause injury, damage to personal property, and may void your warranty.
16. **WARNING: DO NOT** use while under the influence of alcohol or drugs (prescription or non-prescription) as these may impair user's ability to properly assemble or safely operate the appliance.
17. The manufacturer declines any responsibility in the case of improper use of this product. Improper use of this product voids the warranty.
18. Avoid contacting moving parts. Wait until all parts have come to a complete stop and disconnect from the power source before removing any parts of the grinder.
19. **WARNING:** Never feed food into grinder by hand as serious injury may occur, always use provided meat stomper.
20. **WARNING: DO NOT** use fingers to scrape food away from the grinding plate while the grinder is running, doing so may cause serious injury.
21. Thoroughly hand-wash all grinder parts in warm soapy water prior to use. **DO NOT** soak. **NOT DISHWASHER SAFE** (discoloration may occur).
22. Tie back loose hair and clothing. Remove neckties, rings, watches, bracelets or other jewelry before operating the grinder.
23. **DO NOT** operate the grinder without the pan in place.
24. **DO NOT** run grinder without meat in the Grinder Head, severe damage to the Grinder Head and Auger could result.
25. Use grinder on a level, stable surface to prevent tipping. Never move the grinder while unit is in use.
26. **WARNING:** Knife and plates are **SHARP!** To avoid injury, use extreme caution when handling.

27. SAVE THESE INSTRUCTIONS

IMPORTANT WARRANTY INFORMATION PLEASE READ FILL OUT AND RETURN ENCLOSED WARRANTY CARD

THIS WARRANTY COVERS:
LEM 1158 500WATT ELECTRIC MEAT GRINDER.
THE WARRANTY IS EXTENDED TO THE ORIGINAL PURCHASER ONLY.

WARRANTY DURATION: This product is warranted to the original purchaser for a period of one (1) year from the original purchase date. EACH UNIT COMES WITH A WARRANTY CARD, WHICH MUST BE FILLED OUT COMPLETELY AND RETURNED IMMEDIATELY, WITH A COPY OF THE PURCHASING RECEIPT. FAILURE TO RETURN YOUR WARRANTY CARD WILL LIMIT WARRANTY TO 90 DAYS WITH PROOF OF PURCHASE.

WARRANTY COVERAGE: This product is warranted against defective materials or workmanship. The warranty is void if the product has been damaged by accident, misuse, neglect, modification or improper service or repairs by unauthorized personnel. It is also void if damaged in shipment or by other causes not arising out of defects in the materials or workmanship. This warranty does not extend to any units which have been in violation of written instructions furnished.

WARRANTY DISCLAIMERS: This warranty is in lieu of all warranties expressed or implied, and no representative or person is authorized to assume any other liability in connection with the sale of our products. There shall be no claims for defects or failure of performance under any theory of sort, contract or commercial law including, but not limited to negligence, gross negligence, strict liability or breach of contract. The manufacturer declines all responsibility for damage to persons, things or animals arising from the failure to comply with the norms contained in this manual. The manufacturer reserves the right to make modifications at anytime to the models while maintaining the main characteristics described herein. The manufacturer also declines all responsibility for any errors in compiling this manual.

WARRANTY PERFORMANCE: During the above one year warranty period, a product with a defect will either be repaired or replaced after the product has been inspected by a LEM Service Technician. **LEM RESERVES THE RIGHT TO REFUSE WARRANTY PERFORMANCE OR PRODUCT EVALUATION UNLESS THE ORIGINAL SALES RECEIPT OR WARRANTY CARD IS ON FILE.** The repaired product will be in warranty for the balance of the one year warranty period. No charge will be made for such repair or replacement.

IMPORTANT NOTICE: If any parts are missing or defective, please contact our Customer Service Department for assistance at 877-536-7763. (M-F 8:30am to 4:30pm EST) **DO NOT RETURN TO THE STORE WHERE THE ITEM WAS PURCHASED.**

LEM PRODUCTS MERCHANDISE RETURN POLICY WARRANTY SERVICE:

To obtain service under terms of this warranty, please contact us at 877-536-7763 to obtain authorization prior to returning the merchandise. No merchandise will be accepted without prior authorization. Please return the product pre-paid in the original packaging if possible, enclose a copy of your receipt, (Keep a copy of your proof-of purchase for your records.) and include a written explanation of the issue. Ship to LEM Products, 4440 Muhlhauser Rd., Suite 300, West Chester, OH 45011-9767. LEM Products is not responsible for damage incurred in shipping, make certain to pack product properly. Return shipping charges are the responsibility of the purchaser. Packages returned to LEM should be insured for the value of the product to cover any damages that may occur during shipping.

! CAUTION !

Cuts, injuries and/or fire may result from non-compliance with all operating procedures described within this instruction manual.

TROUBLESHOOTING

If your unit fails to operate, contact LEM Products technical assistance Toll Free at 1-877-536-7763. If meat is mashing instead of extruding in strings from the grinding plate, chill the meat to 40°, and check to see that the plate and knife are properly installed. A dull knife or plate will also cause mashing of the meat. For an overheated plug or grinder housing discontinue use and contact technical assistance Toll Free at 1-877-536-7763.

This product is equipped with a polarized AC (Alternating Current) plug (a plug having one blade wider than the other). This plug will fit into the power outlet only one way. (If the plug does not fit fully into the outlet, reverse the plug. If it still does not fit, contact a qualified electrician. Do not modify the plug.

DO NOT DEFEAT THE SAFETY PURPOSE OF THIS POLARIZED PLUG IN ANY WAY.

CLEANING AND MAINTENANCE

HOW TO CLEAN YOUR GRINDER:

Meat remaining in the Grinder Head may be moved through by passing a slice of bread through the Grinder Head.

1. Before clean up of the grinder, switch the appliance off and unplug from electrical socket.
2. Remove the **Meat Stomper (#13)** and **Meat Pan (#14)**.
3. Unscrew **Star Bolt (#15)** and remove the **Grinder Head** by pulling straight out.
4. Unscrew the **Retaining Ring (#1)** and remove all parts from the **Grinder Head**.
Hand wash in warm soapy water. Grinder parts are **NOT DISHWASHER SAFE**.
CLEAN IMMEDIATELY AFTER USE.
5. Rinse with clear hot water and hand-dry **IMMEDIATELY**. **DO NOT** soak.
NOT DISHWASHER SAFE (discoloration may occur).
6. We advise you to lubricate the **Knife** and the **Grinding Plates** with silicon spray (available at **LEM Products**.)

! WARNING! !

Always be as thorough as possible when cleaning and sanitizing components. Any parts exposed to raw meat may harbor or develop bacteria possibly causing illness or death.

! CAUTION !

Before cleaning, assembling or disassembling meat grinder, make sure the grinder motor is OFF and the plug is removed from the outlet/power source.

GRINDER FEATURES

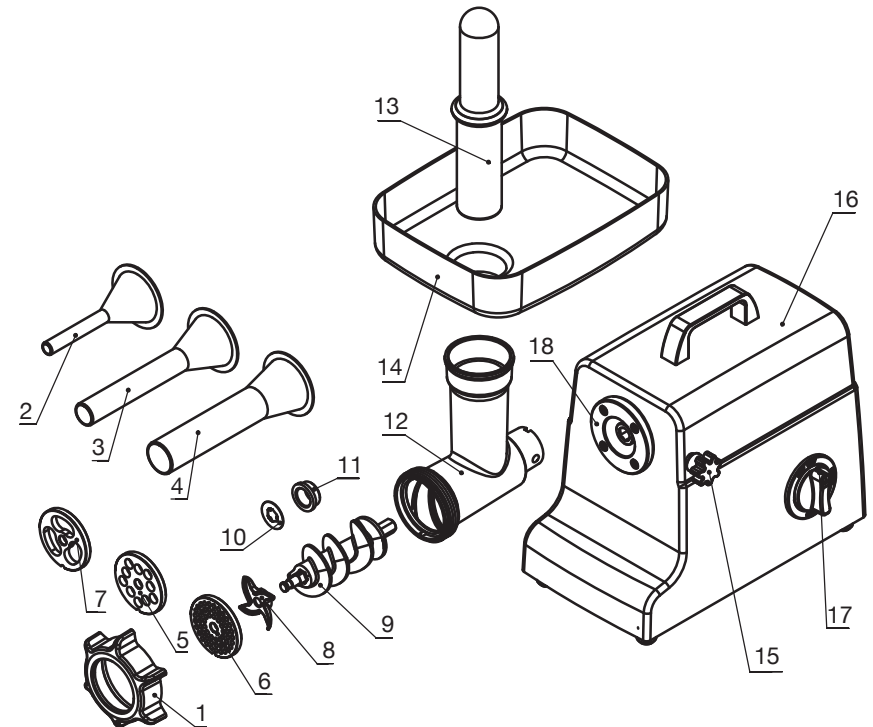

Part #	Description	QTY
1	RETAINING RING	1
2	1/2" STUFFING TUBE	1
3	1" STUFFING TUBE	1
4	1 3/8" STUFFING TUBE	1
5	10 mm PLATE	1
6	4.5 mm PLATE	1
7	STUFFING PLATE	1
8	KNIFE	1
9	AUGER	1

Part #	Description	QTY
10	AUGER WASHER	1
11	AUGER BUSHING	1
12	HEAD	1
13	STOMPER	1
14	MEAT PAN	1
15	STAR BOLT	1
16	HOUSING	1
17	POWER SWITCH	1
18	HEAD ATTACHMENT HUB	1



Before cleaning, assembling or disassembling meat grinder, make sure the grinder motor is OFF and the plug is removed from the outlet/power source.

GRINDER ASSEMBLY AND OPERATION

BEFORE USE: (See Diagram page#3)

1. Wash all parts of the head in hot, soapy water. This will remove any grease residue and dirt left from the manufacturing process.

DO NOT PUT PARTS IN DISHWASHER

2. The **Star Bolt (#15)** on the side of the motor must be unscrewed enough so the end of the bolt is not visible inside the **Head Attachment Hub (#18)**. Insert the **Grinder Head (#12)** straight into the **Head Attachment Hub**, lining up the rear notches on the **Grinder Head** with the head locator tabs inside the Hub. Firmly tighten Star Bolt to hold **Grinder Head** in the upright position.
3. Check that **Washer (#10)** is installed on the drive end of the **Auger (#9)**.
4. Insert **Auger** (hex end in first) into **Grinder Head**, turning it slowly to line up the **Auger Drive** with the **Grinder Drive Gear**. (**Auger** will seat fully into the gear.)
5. This grinder comes with a **One-Way Knife**. This **Knife (#8)** can only be installed on the **Auger** one direction. Place **Knife** on the square of the **Auger Stud** with the sharp blades facing out.
6. Place **Grinding Plate (#5 or #6)** on the **Auger Stud** in front of the **Knife**. Make sure the notch in the Plate is lined up with the locating pin in the bottom of the **Grinder Head**.
7. When assembled correctly the **Plate** will stick out past the end of the **Grinder Head** by 1/8"-3/16".
8. Screw **Retaining Ring (#1)** onto **Grinder Head** until hand tight. Do not over tighten. Over tightening will cause undo wear on the **Knife** and **Plate**.
9. Insert **Meat Pan (#14)** fully into the feed tube on the **Grinder Head**.

GRINDING

When making burger from wild game, add a minimum of 10% pork fat to the meat. This will give the burger moisture, but still not make it fatty. If pork fat is not available, use beef fat.

Cut meat into small pieces that will easily fit into the throat of the grinder head. Meat should be 40° or colder and free of gristle, sinew, silver skin, and bone. Feed meat slowly into the feed tube of the head. If necessary use the **Meat Stomper (#13)** to push meat into the throat of the head. Do not force meat, allow grinder to do the work.

NEVER USE FINGERS TO PUSH MEAT INTO THE HEAD

Grind meat through the coarse plate first, turn motor off and unplug the grinder. If a smaller grind is desired chill meat. Then, remove the coarse plate and clean the head of sinew, fat or gristle that has accumulated during the first grind. Assemble the unit with the fine plate, plug grinder in and regrind the meat.



Only use the included meat stomper when feeding food into the grinding head. DO NOT push food into the throat with your fingers — Serious injury could occur.

GRINDER USAGE AND OPERATION

STUFFING SAUSAGE CASINGS:

There are several methods for stuffing sausage with your grinder. Before you begin, review the helpful tips listed below:

- When making sausage, use at least 20% fat with your meat and grind it like a burger. Without adequate fat, your sausage will be dry when cooked, and will tend to crumble when cut or sliced.
- Make sure the meat is well-chilled (28°-32° F).
- Select your casing and prep if necessary.
- Slide casings onto stuffing tube making sure to leave the end of the tube and casings open. Turn grinder on and feed meat into the head until meat is at the end of the stuffing tube. Stop grinder and pull casing out past the opening of stuffing tube about 1". Tie a knot, twist, or clip the casing. Restart grinder. This procedure will keep the casing from filling up with air when you first start stuffing. Continue to feed meat into head until the casing is filled. Use Meat Stomper sparingly when necessary.
- Stuff the casing firm, but not to the bursting point. To divide the sausage into links, give the casing two or three quick twists before adding more meat. Twist links in alternating directions (clockwise for the first, counter-clockwise for the second) to ensure that they keep their forms.
- If air bubbles form in your sausage, you can pop them with a sharp, sterilized needle.

METHOD #1 STUFFING SAUSAGE:

1. First grind the meat with the **10mm Plate (#5)** for a course grind. For a finer grind, repeat for a second grind with the **4.5mm Plate (#6)**. (Unplug the grinder, remove **10mm Plate**, install the **4.5mm Plate**.)
2. Mix seasoning and water into the meat.
3. Unplug the grinder, remove the grinder **Knife** and **Plate**. Install the **Stuffing Plate (#7)** in place of the **Knife** and **Plate**. Put **Stuffing Tube (#2, #3 or #4)** in front of the **Stuffing Plate** and secure with the **Retaining Ring (#1)**.
4. Slide casings on stuffing tube.
5. Feed seasoned meat through the grinder into casings.

METHOD #2 STUFFING SAUSAGE:

1. Cut meat into 1" chunks.
2. Mix seasoning into the meat or marinate the meat.
3. Unplug the grinder, install the **Knife**, **4.5mm Plate** and **Stuffing Tube**.
4. Slide casings on stuffing tube.
5. Feed ground meat into the grinder.
6. Fine grind directly into casings.

METHOD #3 STUFFING SAUSAGE:

1. First grind the meat with the **10mm Plate** for a coarse grind.
2. Mix seasonings into meat or marinate the meat.
3. Unplug the grinder, remove the **10mm Plate**. Install the **Knife**, **4.5mm Plate** and **Stuffing Tube**.
4. Slide casings on stuffing tube.
5. Second grind the meat through this plate directly into the casings.