



User's Manual

Wine Cooler

Model: HS-144W

Before using your product, please read this manual carefully and keep it for future reference.



Content

Hint for Castoff Disposal.....	3
Hints on Safety & Warning.....	4
Know About Wine Cooler.....	6
Placement of Wine Cooler	6
Level the Wine Cooler.....	7
Pay Attention to Room Temperature & Ventilation.....	7
Ventilation.....	7
Connect Wine Cooler with Power Source.....	8
Set UP Temperature.....	8
Placement of Beverage Bottle.....	9
Use Temperature Area in Chilling Cabinet.....	9
Practical Skills for Storage of Wine.....	10
Drinking Temperature.....	10
Power-off & Stop Using of Wine Cooler.....	11
Cleaning Wine Cooler	11
Energy Saving.....	12
Operation Noise.....	12
Troubleshooting By Yourself.....	12

Hint for Castoff Disposal

Disposal of Waste Package

The package is used to protect the wine cooler during the transportation. All the materials are harmless to environment and reusable.

To know the current channel for disposal of castoff, please consult your professional dealers or the local administrative authority.

Warning

For the discarded wine cooler:

1. Please pull out the plug of power source.
2. Please sever the electric cord and take it off with power plug.

The wine cooler contains cooling agent and the insulation layer contains gas. The cooling agent and the insulated gas must be disposed by professional personnel. Please do not damage the loop pipeline of the cooling agent before it's disposed by professional personnel.

Hints on Safety & Warning

Before Operation of Wine Cooler

Please read the User Manual carefully!

It contains some important information on placement, use and maintenance of wine cooler.

Please keep all the data for future use or the next user of the wine cooler.

Technical Safety

- The wine cooler contains a little cooling agent - R134a, which is harmless to the environment. Please pay attention not to damage the loop pipeline of the cooling agent in the transportation or installation process. The ejected cooling agent may cause injury to eyes or may ignite by itself.

When It's Damaged

- The flame or fire source should be kept away from the wine cooler.
- Please ventilate the room thoroughly for several minutes.
- Pull out the power plug.
- Inform after-sales service personnel.

The more cooling agent the wine cooler has, the bigger the space to place the wine cooler should be. For every 8g cooling agent, there must be at least 1m³ of space in the room. The quantity of wine cooler is marked on the nameplate of the back-plate of the wine cooler.

- The replacement of power cord and other repair activities can only be carried out by the after-sales service personnel specified by the manufacturers. Improper installation or repair may cause big dangers to users.

During Use

- Do not use electric appliance (such as: heater, electric ice maker, etc.) within the inside of the wine cooler.

Danger of Explosion!

- Do not use steam type cleaning equipment to clean the wine cooler or

defrost! Steam may enter the electric elements and cause short circuit.

Danger of Electric Shock!

- Don't remove frost or ice layers with sharp or keen-edged object. Otherwise, the cooling agent pipeline may be damaged. The ejected cooling agent may cause injury to eyes.
- Do not store products that contains combustible gas (such as: spray bottle) or explosive materials in the wine cooler.

Danger of Explosion!

- Do not use the base or the door of the wine cooler as footplate or support.
- When you defrost or clean the wine cooler, please pull out the power plug or disconnect the protective equipment. When you pull out power plug, please hold the plug rather than pull the power cord.
- The wines with high alcohol content must be sealed and stored vertically.
- Avoid contamination of grease to the plastic components and the door sealing components of the wine cooler, or the plastic components and the door sealing components of the wine cooler will appear small holes.
- Do not envelop or close the ventilation or exhaust holes.

Children

- Do not give the package or other components to children for play. The folded paperboard and the plastic film may cause danger of suffocation!
- The wine cooler is not toy of children!

General Regulation

The wine cooler is applicable for

- Chilling storage of beverage

The wine cooler is only designed for household.

The series of wine cooler execute the following standards:

National Standard

GB 19606-2004 *Noise limit value for household and similar electrical*

appliances.

GB-T 23777-2009 *Wine Cooler*

International or other national or regional standards:

UL 250 BULLETINS-2003 *U.S.A. household fridge safety requirements*

IEC 61000-3-4-1998 *Electromagnetic compatibility (EMC) - Limits -
Limitation of emission of harmonic currents in low-voltage power supply
systems for equipment with rated current greater than 16 A*

UL 250 BULLETINS2-2003 *U.S.A. household fridge safety
requirements*

Enterprise Standard

Q/MB 004-2007 *Wine Cooler*

Know About Wine Cooler

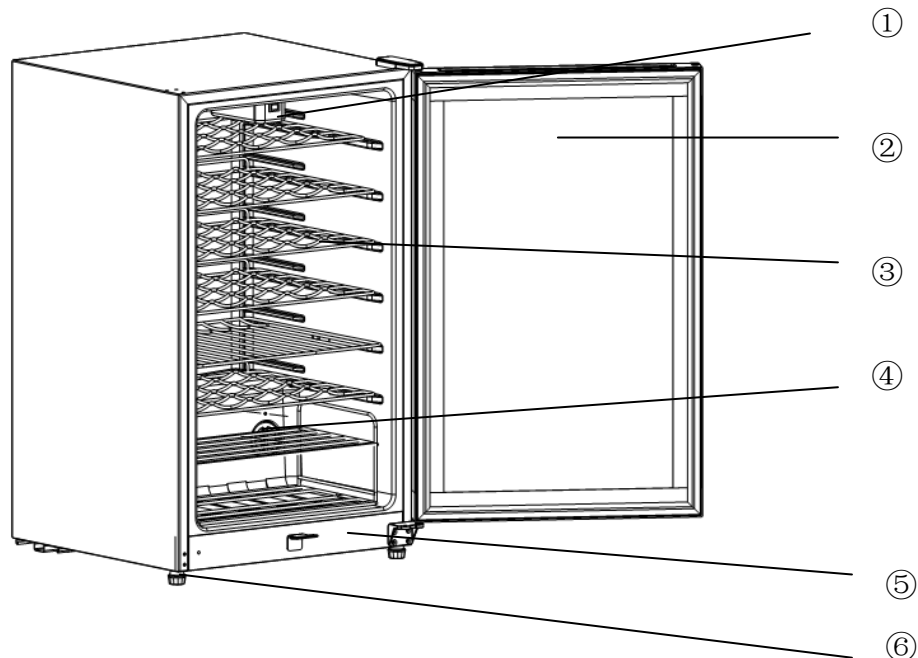

Fig. 1

The illustration might be different from the actual products.

- ① Lamp Component
- ② Glass Door
- ③ Steel Wire Racks
- ④ Temperature Knob
- ⑤ Control Switch of Lamp
- ⑥ Adjustment Leg

Placement of Wine Cooler

The wine cooler should be placed in dry and ventilated room. The location of the wine cooler should not be irradiated by direct sunshine. The wine cooler should be far away from heating sources, such as: cooking stove or heating radiator. If the wine cooler has to be placed near heating source, please adopt proper heating insulation board for insulation or keep the wine cooler at least the following minimum distances away from the heating sources:

For electric stove: 3 cm.

For oil or coal stove: 30 cm.

Replacement of Door Hinge

The door hinges of this wine cooler can be interchanged between the left and right sides.

Level the Wine Cooler

Place the wine cooler on the planned location and level it.

The front screw leg is adjustable.

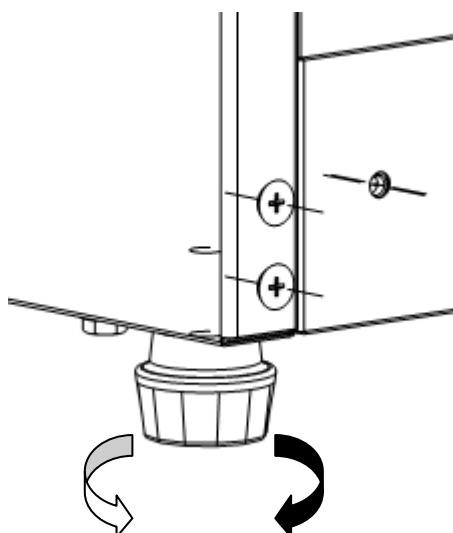

Pay Attention to Room Temperature & Ventilation

The climate type is marked on the model nameplate. It indicates the room temperature range for operation of wine cooler.

Climate Type	Indoor Temperature Range
N	+16°C to 32°C
ST	+18°C to 38°C
T	+18°C to 43°C



Notice

If the room temperature is lower than +16°C, the wine cooler may not be able to work normally, because if the room temperature is too low, the temperature sensitive goods might be damaged.

If the room **temperature and humidity is too high**, the glass door of the wine cooler may have congealed dew.

Ventilation

The hot air on the side wall of the wine cooler must be exhausted freely, or the power consumption will be increased to increase the power of the compressor.

Therefore, the distance between the wine cooler and the wall or the nearby furniture should not be less than 4 cm.

This distance is the minimum requirement if you are to open the door to 90 degree.

Connect Wine Cooler with Power Source

After placing the wine cooler, please wait for at least half an hour before the wine cooler can be operated. This is because the engine oil in the compressor may flow into the cooling system during the transportation process.

Before the first running, please clean the inside chambers of the wine cooler (Please see the section on cleaning).

The power socket should be in such as place, where is reachable conveniently. Please use a socket that's installed according to the requirements. The wine cooler should be connected with 115V/60Hz AC power.

Warning!

In any case, please do not connect the wine cooler to the electronic energy saving power plug or the converter (such as: solar energy equipment, ship's electric grid) that convert DC into 115V AC.

Turn on the wine cooler and set up temperature

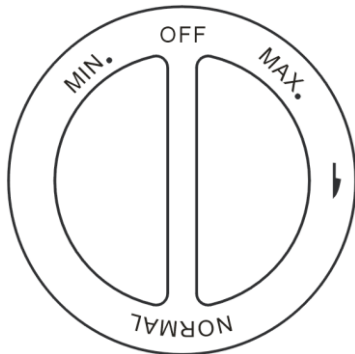

After the wine cooler has been turned on, turn the temperature control knob to adjust the level of temperature controller. MAX is the highest level, NOR is the middle level and MIN is the lowest level.

Hints for Operation

In the operation of compressor, the back wall of the chilling chamber will form water ball or frost because this is determined by the functions of wine cooler. You do not need to defrost or wipe off water drops because the back wall is able to defrost automatically. The defrosted water will be collected to discharge channel and the water will flow to the water receiver above the compressor and will be vaporized there.

When there is too much frost at the back of inner side of cabinet, pls turn off the power until the defrosting is finished.

Placement of Beverage Bottle

When you place the beverage bottles, please note:

- The number of bottles that can be put on the bottle racks is recorded on User Manual of this model of wine cooler.
- To maintain the perfect air ventilation in the wine cooler, the bottle should not touch the back wall of the chilling chamber.
- The number of bottles might be different for different bottles with different shapes and sizes.
- Because some space is occupied by the compressor, the lower part of the wine cooler is comparatively low and it can be used to place beverage tins or the short wine bottles.

Effective Cubage

Please see the model nameplate on the wine cooler for the description on effective cubage.

Use Temperature Area in Chilling Cabinet

Due to the air circulation in the wine cooler, some areas with different temperatures are generated:

The upper area has the highest temperature

The lower area has the lowest temperature

Placement of Beverage

Please store different wines according to the following sequence from up to

down:

- Strong red wine
- Rose wine and gentle red wine
- White wine
- Champaign and light sparkling wine

We recommend pour wine into glass at the temperature lower than the drinking temperature because the temperature of wine will increase quickly when it's poured into glass.

Practical Skills for Storage of Wine

- The bottled wine should not be stored in the chilling chamber in a whole case or box before the whole case or box has been opened.
- When old bottles are placed in the wine cooler, please make sure that the bottle cork can always be wetted. Do not leave space between the wine and the bottle cork.
- The open type bottle rack is especially suitable because it will not separate air circulation, so the atmosphere moisture on the bottle can be quickly dried by air ventilation.
- Before you drink the wine, the wine temperature should be risen slowly: For example, you can place the rose wine or red wine on the table respectively 2-5 hours or 4-5 hours before you drink, so you can have the proper drinking temperature. On the contrary, the white wine can be placed on the table directly. The champagne should be stored in the wine cooler until you want to dink.
- Please make sure that the temperature of the wine is always lower than the ideal drinking temperature because when you drink the wine into glass, the temperature of the wine will increase 1 - 2°C immediately!

Drinking Temperature

The correct temperature of pouring wine determines the smell of wine, as well as the taste of wine.

We recommend you pour wines into glass at the following drinking temperatures:

Wine Type	Drinking Temperature
Bordeaux red	18°C
Côtes du Rhône red/Barolo	17°C
Burgundy red/Bordeaux red	16°C
Port	15°C
Young Burgundy red	14°C
Young red wine	12°C
Young Beaujolais/all white wines with little residual sugar	11°C
Old white wines/Chardonnay	10°C
Sherry	9°C
Young white wines from late vintage	8°C
White wines Loire/Entre-deux-Mers	7°C

Power-off & Stop Using of Wine Cooler

Turn off Wine Cooler

Pull out the power plug, and the wine cooler will be turned off.

Stop Using Wine Cooler

If you're not going to use the wine cooler for a long time:

1. Pull out power plug
2. Clean the wine cooler
3. Open the door of wine cooler.

Cleaning Wine Cooler

You should do the following operation:

1. Pull out power plug or disconnect the protecting device!
2. Scrub the sealing parts of the door only with clean water and soon wipe the water off thoroughly.

3. Please clean the wine cooler with slightly warm water and a little detergent agent. Do not splash water to the operation control element or the lighting system on the glass door.

4. Reconnect the wine cooler with power source and then connect it with power source after it has been cleaned.

Hints

Do not use detergent agent or solvent containing sands or acid.

Please regularly clean the scupper, so the dew can be discharged. You can use small stick or similar objects to clean the scupper.

Energy Saving

- Please place the wine cooler in dry and ventilated room! The wine cooler should not be placed on the location where can be directly irradiated by sunshine or where is close to heating sources, such as: heating radiator or cooking stove, etc. If necessary, you can use heating insulation board.
- Try to shorten the opening time of door of wine cooler!
- First let beverage cool down and then place the beverage into wine cooler!

Operation Noise

Normal Noise

Hum – the noise is cause by operation of the refrigeration unit.

Coo, rumbling or gurgle – the noise is caused by flow of cooling agent in the pipeline.

Noise that can be removed easily

The noise caused by unevenness of placement of wine cooler

You can use gradienter to correct and level the wine cooler. You can use screw leg to level it or you can place mat under the wine cooler to level it.

The noise generated when the wine cooler leans against other furniture.

Move the wine cooler away from the furniture or equipment, against which the wine cooler leans.

The noise caused by mutual touch of vessels

Slightly separate the bottles or vessels from each others

Troubleshooting By Yourself

Before you call the after-sales service phone number, please check if you are able to remove the failures according to the following hints.

Failures	Possible Causes	Remediation Measures
Temperature is quite different from setting value		Sometimes, the problem can be removed if you just turn off power of the wine cooler for 5 minutes and then restart it. If the temperature is too high, you can check it several hours later to see if the temperature is consistent with the setting value. If the temperature is too low, you can check the temperature again in the next day.
The inside of wine cooler is not cold	You open the door of wine cooler very often; You place too many beverage bottles in it	Reduce the frequency to open the door of wine cooler. Wait for 4 – 5 hours.
The wine cooler doesn't cool down	The wine cooler is disconnected with power source of the power supply has stopped; the power plug is not inserted firmly	Press POWER button; Check if power supply is connected.
LED lamp is not on	LED lamp is damaged	Please contact the local after-sales service personnel for repair
Glass door have congealed dew	Indoor temperature and humidity is too high, temperature of wine cooler was set too lower.	Properly turn up the setting temperature of wine cooler, while dry off dew on the glass door

For more information, please visit our website
www.midea.com

