

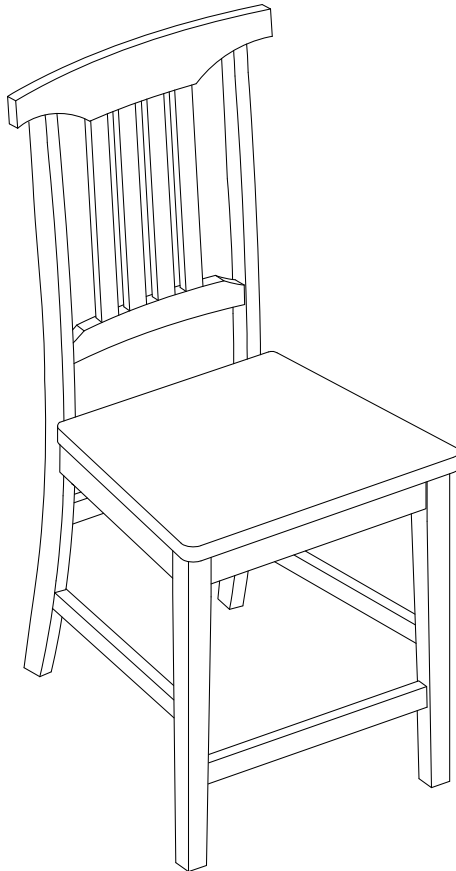

OKLC-DT OAKLAND PUB CHAIR ASSEMBLY INSTRUCTIONS



WARNING

1. Do not use this product unless all screws and bolts are securely tightened.
2. Check that all screws and bolts are tight every three months or as needed.
3. Dispose of packing material properly. Do not use plastic cover as head covering. It may cause suffocation.
4. Do not use this product as a stepladder.
5. Use this product for its intended purpose only.
6. **Intended for residential use only.**

OSP DESIGNS SEATING LIMITED WARRANTY

OSP Designs chairs are warranted from the date of purchase against failure due to material and workmanship as follows:

- 5 Years on all non-moving metal parts.
- 2 Years on component parts including Control mechanisms, pneumatic cylinders, wood, plastic parts, base and casters.
- 1 Year on upholstery fabric and foam against wear and deterioration.

To make a warranty claim, contact Parts Department. Provide model number, proof of purchase, description of the problem and obtain return authorization.

At it's option Office Star Products will:

- (a) Supply compatible components of current manufacture.
- (b) Repair the customer's component. The customer must prepay freight on any components returned to the factory. Return freight on components still in warranty will be paid by Office Star Products.

*All warranties are limited to the original purchaser for normal Residential usage by persons weighing 200 lbs. or less. This warranty will not cover labor, freight or damage from misuse, abuse, negligence, alteration, accident, vandalism, rusting, acts of nature or any other event beyond the control of Office Star Products. The warranty does not cover cosmetic damage that may result from normal use. Liability for incidental or consequential damages is excluded. The user assumes all risk of injury resulting from use of this product. This warranty gives you specific legal rights, and you may also have other rights which vary from state to state.

Our quality standards are among the highest in the industry. Sometimes, no matter how hard we try, there are times when parts are damaged or missing. Our Parts Department will do everything possible to promptly remedy the problem. Contact us via e-mail parts@officestar.net, by Fax 1-909-930-5629, or toll free parts number 1-800-950-7262, Monday through Friday 8:00 a.m. - 5:00 p.m. Pacific Time.

PARTS LIST

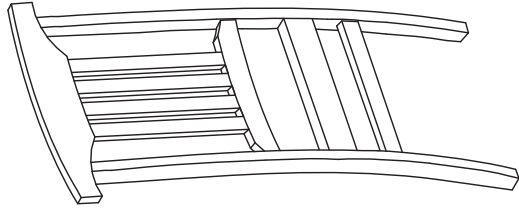

(A) Chair Back (1PC)

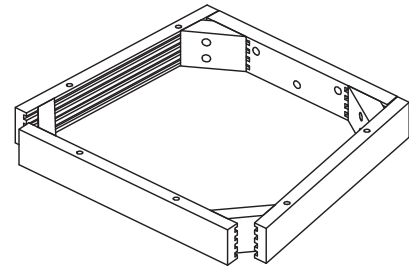

(B) Seat Frame (1PC)

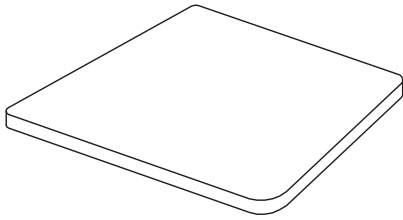

(C) Seat (1PC)

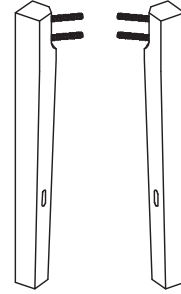

(D) Front Leg (Left & Right) (2PCS)

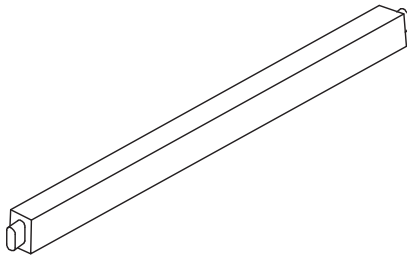



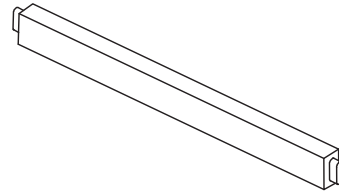



(E) Side Stretcher (2PCS)

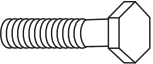
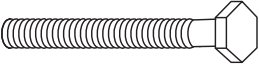

(F) Front Stretcher (1PC)

HARDWARE LIST

NO	DRAWING	DESCRIPTION	SIZE	QUANTITY
1		Short Bolt	1/4" x 1 3/4"	3 PCS
2		Long Bolt	1/4" x 3"	4 PCS
3		Screw	5/32" x 1 1/2"	12 PCS
4		Washer	5/16" x 6/8" x 0.008"	11 PCS
5		Lock Washer	5/16" x 1/2" x 0.008"	11 PCS
6		Nut	5/16"	4 PCS
7		Open Wrench		1 PC

Phillips Screwdriver also needed for assembly (not provided).

STEP 1

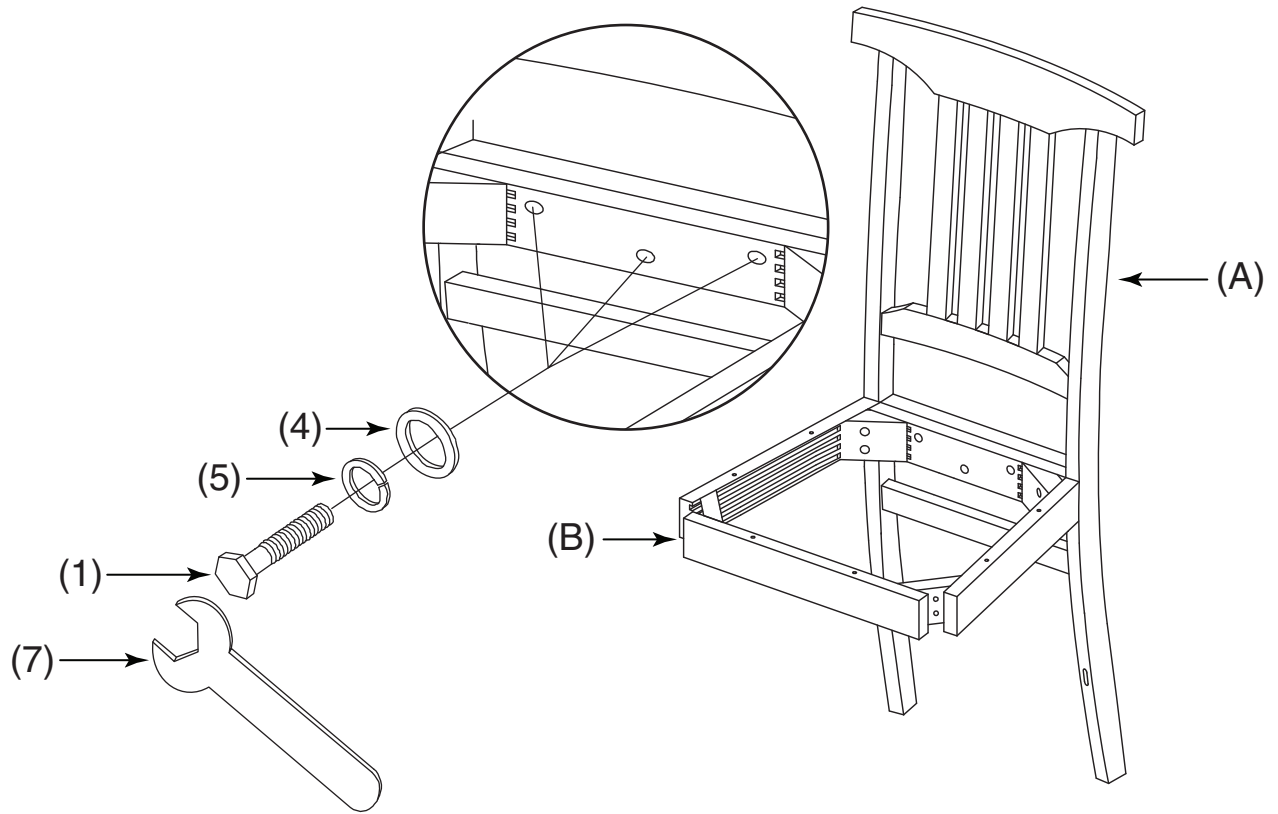

DO NOT FULLY TIGHTEN BOLTS.

STEP 2

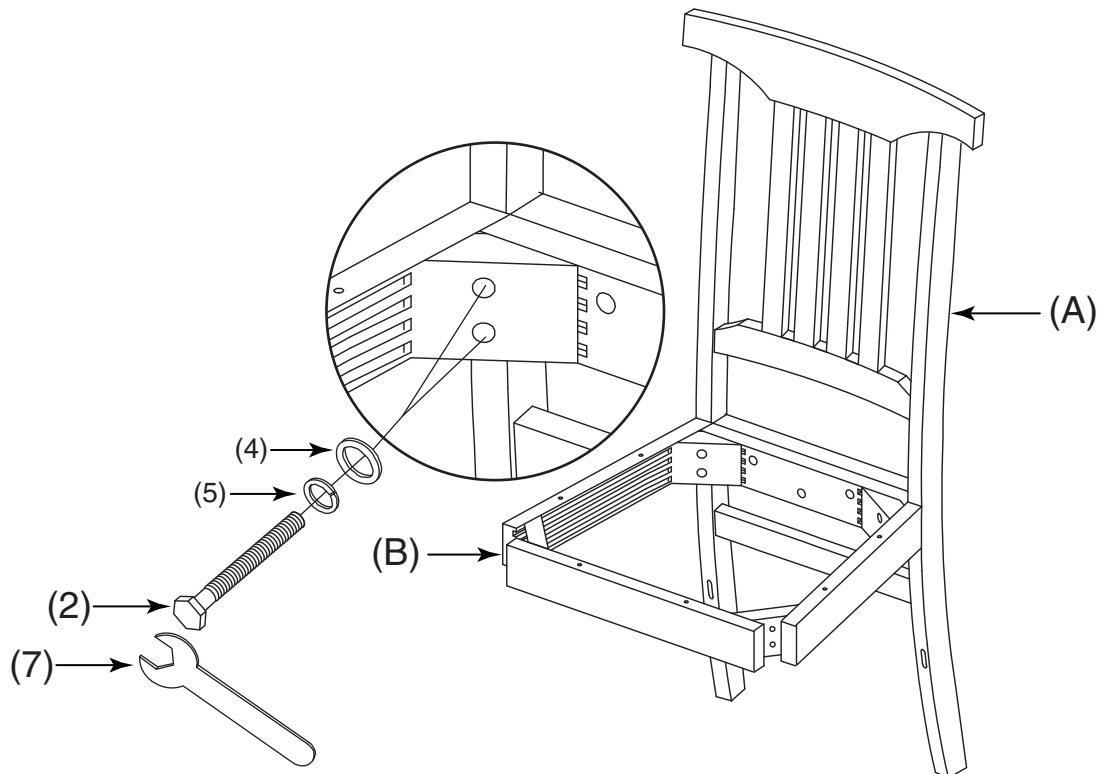

DO NOT FULLY TIGHTEN BOLTS.

STEP 3

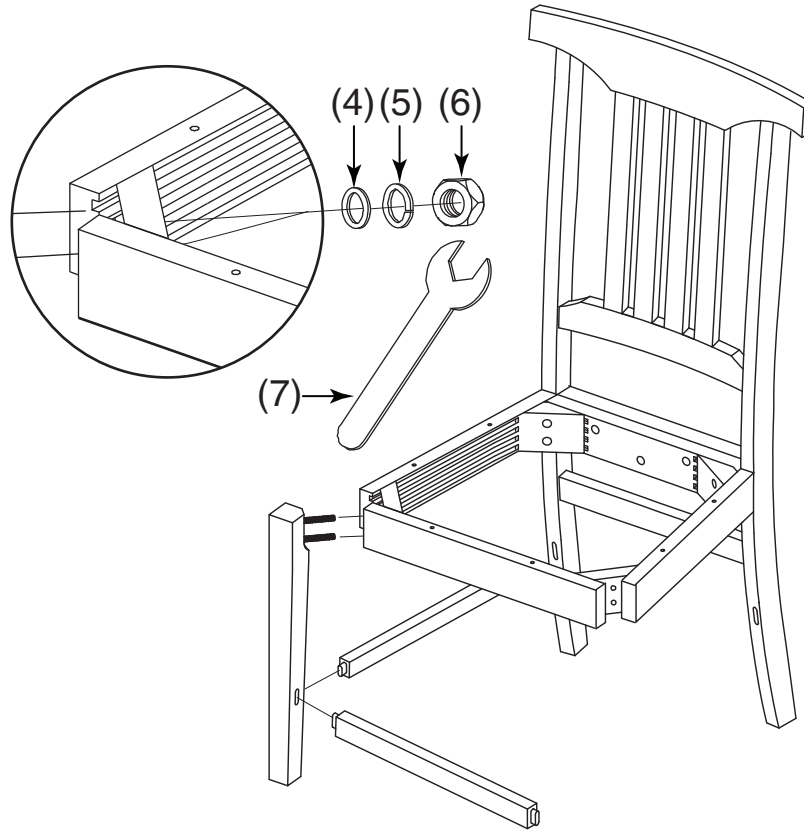

DO NOT FULLY TIGHTEN NUTS (6).

STEP 4

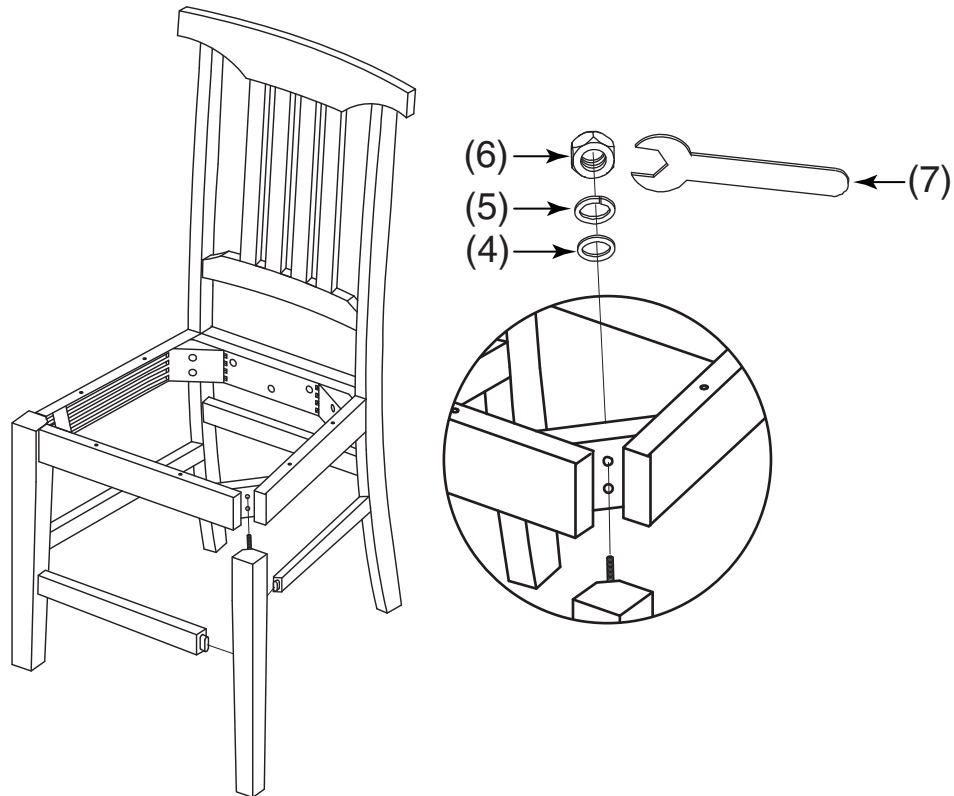

APPLY FIRM PRESSURE TO ALIGN & FULLY TIGHTEN ALL BOLTS (1 & 2) & NUTS (6) WITH KEY WRENCH (7).

STEP 5

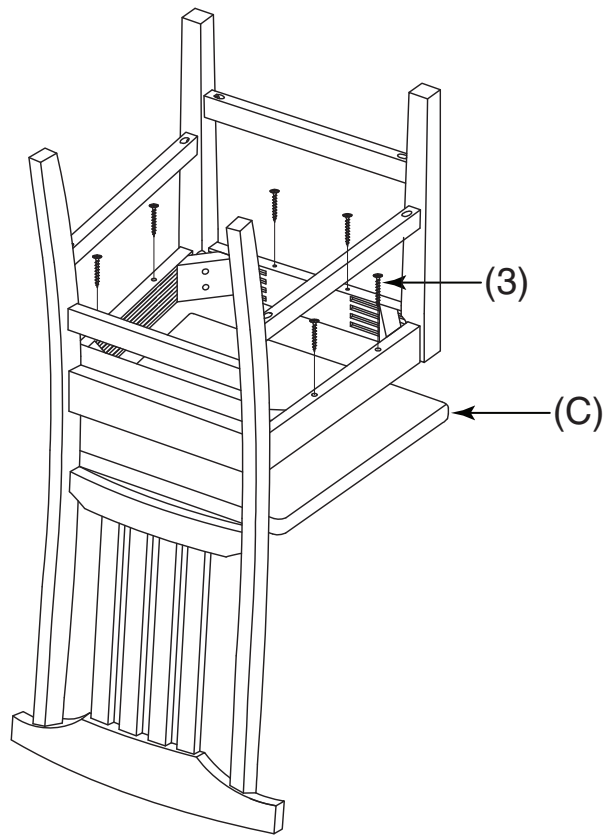

FULLY TIGHTEN ALL SCREWS (3) USING PHILLIPS SCREWDRIVER (not provided).