

Model ML103 Parts List

A = Standard Equipment

O = Circuit Diagram

Item#	Part#	Description	Q'ty	Unit
001	GM00001496	HOUSING L/R ASS' Y ROS81030003	1	PC.
002	GM00001495	SWITCH HOLDER ASSY ROS81030002	1	PC.
003	GM00001024	SCREW 3X12 B0130120202	2	PC.
004	GM00001493	MAIN CIRCUIT ASSY ROS81030001	1	PC.
005	GM00001492	LENZ ROS81030000	1	PC.

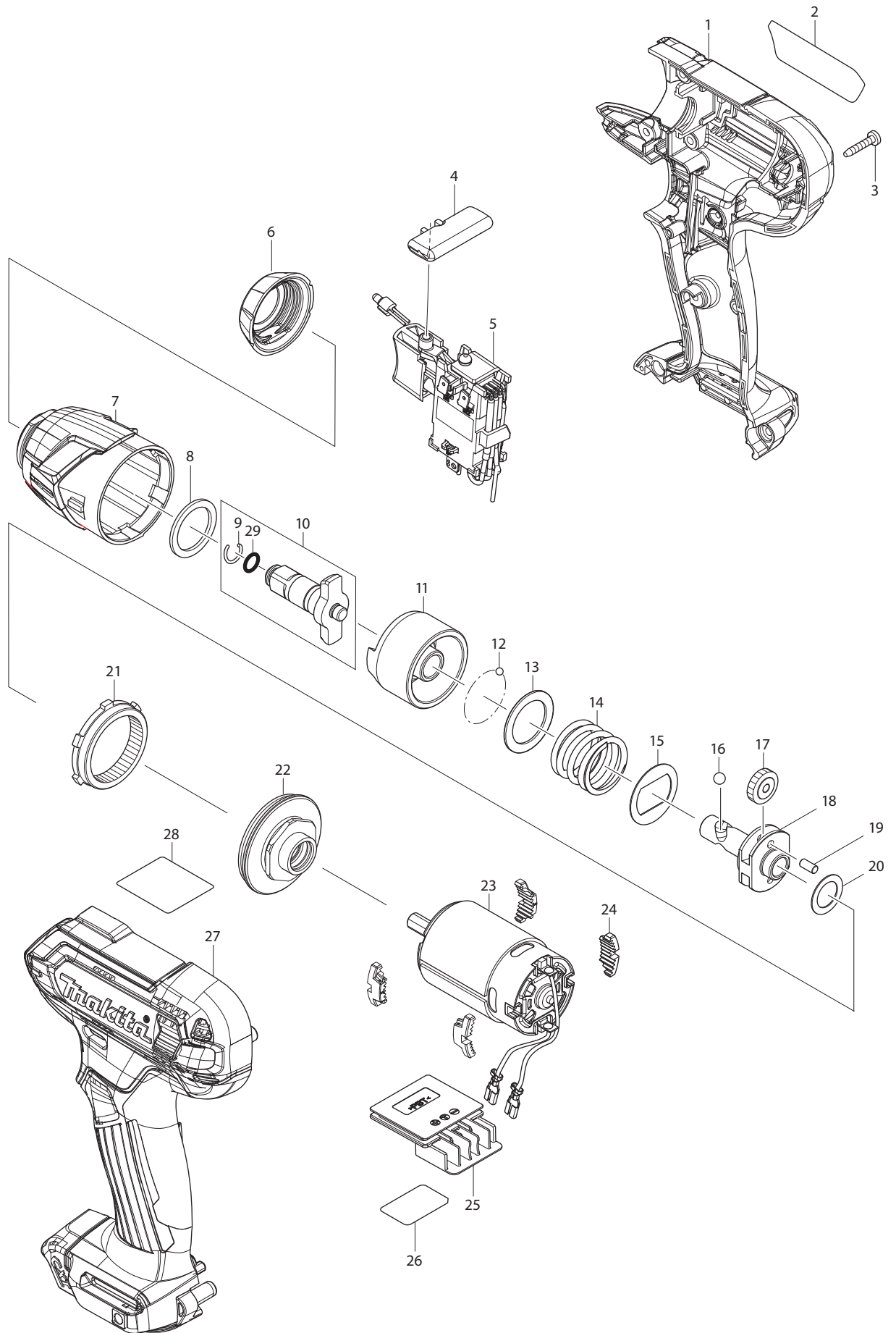

Model WT02 R1/Z Parts List

A = Standard Equipment

O = Circuit Diagram

Item#	Part#	Description	Q'ty Unit
001	183J75-5	HOUSING SET	1 PC.
	C10 252126-6	HEX. LOCKING NUT M4-7	2 PC.
	D10	INC. 27	
002	854M37-5	WT02 NAME PLATE	1 PC.
003	266429-2	TAPPING SCREW 3X16	8 PC.
004	456039-5	F/R CHANGE LEVER	1 PC.
005	632M06-4	SWITCH UNIT	1 PC.
006	422228-4	BUMPER	1 PC.
007	140B03-5	HAMMER CASE COMPLETE	1 PC.
008	261140-1	NYLON WASHER 20	1 PC.
009	233943-3	RING SPRING 8	1 PC.
010	135932-3	ANVIL ASS'Y	1 PC.
	D10	INC. 9,29	
011	324894-2	HAMMER	1 PC.
012	216019-1	STEEL BALL 3	24 PC.
013	267380-9	FLAT WASHER 20	1 PC.
014	234064-4	COMPRESSION SPRING 21	1 PC.
015	267813-4	WASHER 21	1 PC.
016	216002-8	STEEL BALL 4.8	2 PC.
017	226190-3	SPUR GEAR 18	2 PC.
018	327127-4	SPINDLE	1 PC.
019	268217-3	PIN 3.5	2 PC.
020	253052-2	FLAT WASHER 12	1 PC.
021	226191-1	INTERNAL GEAR 45	1 PC.
022	140B04-3	BEARING BOX COMPLETE	1 PC.
	C10 213188-9	O-RING 13	1 PC.
023	632L96-1	MOTOR COMPLETE	1 PC.
024	422273-9	CUSHION	4 PC.
025	644813-5	TERMINAL	1 PC.
026	854M44-8	WT02 SERIAL NO. LABEL	1 PC.
027	183J75-5	HOUSING SET	1 PC.
	C10 252126-6	HEX. LOCKING NUT M4-7	2 PC.
	D10	INC. 1	
028	817D86-9	CAUTION LABEL	1 PC.
029	213960-9	O RING 5	1 PC.
A01	266622-8	+ TRUSS HEAD SCREW M4X12	1 PC.
A02	346909-5	HOOK	1 PC.
A03	831497-0	TOOL BAG	1 PC. (WT02R1)
A07	***DC10WD	DC10WD BATTERY CHARGER	1 PC. (WT02R1)
	D10	COMPO-PARTS	
A08	BL1021B	BATTERY BL1021B SET (197414-3)	2 PC. (WT02R1)
A09	456128-6	BATTERY COVER	2 PC. (WT02R1)

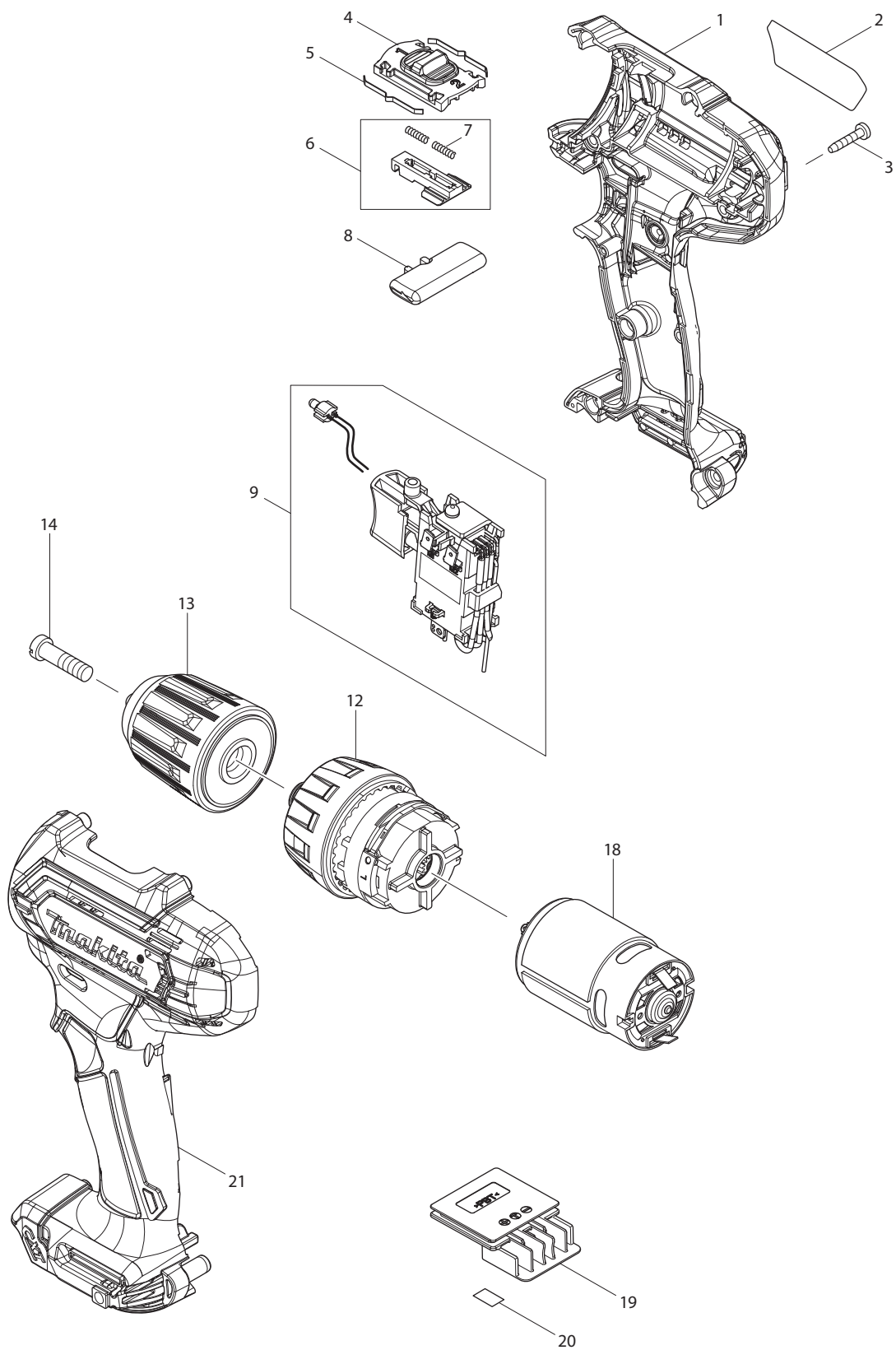

Model FD09R1, FD09Z Parts List

A = Standard Equipment

O = Circuit Diagram

Item#	Part#	Description	Q'ty Unit
001	183K90-5	HOUSING SET	1 PC.
	C10 252126-6	HEX. LOCKING NUT M4-7	2 PC.
	D10	INC. 21	
002	855E34-6	FD09 NAME PLATE	1 PC.
003	266429-2	TAPPING SCREW 3X16	9 PC.
004	459026-3	SPEED CHANGE LEVER	1 PC.
005	232493-5	LEAF SPRING	2 PC.
006	127127-2	CHANGE LEVER ASSEMBLY	1 PC.
	D10	INC. 7	
007	233025-1	COMPRESSION SPRING 2	2 PC.
008	456039-5	F/R CHANGE LEVER	1 PC.
009	632J77-3	SWITCH UNIT	1 PC.
	C10 620625-0	LED CIRCUIT	1 PC.
012	127125-6	GEAR ASSEMBLY	1 PC.
013	763238-5	KEYLESS DRILL CHUCK 10	1 PC.
014	251468-5	- FLAT HEAD SCREW M6X22	1 PC.
018	629395-8	DC MOTOR	1 PC.
019	644813-5	TERMINAL	1 PC.
020	855E41-9	FD09 SERIAL NO. LABEL	1 PC.
021	183K90-5	HOUSING SET	1 PC.
	C10 252126-6	HEX. LOCKING NUT M4-7	2 PC.
	D10	INC. 1	
A01	251314-2	+ SCREW M4X12	1 PC.
A02	346909-5	HOOK	1 PC.
A04	821661-1	PLASTIC CARRYING CASE	1 PC. (FD09R1)
	C10 417724-5	LATCH	2 PC.
A05	818R05-2	FD09R1 MODEL NO. LABEL	1 PC. (FD09R1)
A08	456128-6	BATTERY COVER	1 PC. (FD09R1)
A09	***DC10WD	DC10WD BATTERY CHARGER	1 PC. (FD09R1)
	D10	COMPO-PARTS	
A10	BL1021B	BATTERY BL1021B SET (197414-3)	2 PC. (FD09R1)