

# Quiet Glide Rolling Ladders

## Standard 16" Wide ladder

Here is an easy way to order your Hardware Kits

**1** Determine what type of *Ladder Hardware Kit* you will need.

Hardware Kit includes:

- Top Roller Guides (2)
- Bottom Rollers (2)
- Rung support kits (7) enough for 8" ladder
- Fasteners

**In stock ready to ship**



Black

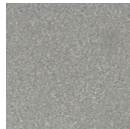

Satin Nickel



Hammered  
Antique Brass  
Pattern may vary



Oil Rubbed  
Bronze



Made  
in the U.S.A.

### 1A 16" Ladder Hardware Kits with standard wheel

Part#	Description	Image	Finish
QG.200.08	Rolling		Black
QG.200.03*	Rolling		Hammered Antique Brass
QG.200.07	Rolling		Oil Rubbed Bronze
QG.200.02	Rolling		Satin Nickel
QG.500.08	Rolling Hook**		Black
QG.500.03*	Rolling Hook**		Hammered Antique Brass
QG.500.07	Rolling Hook**		Oil Rubbed Bronze
QG.500.02	Rolling Hook**		Satin Nickel
QG.700.08	Swivel**		Black
QG.700.03*	Swivel**		Hammered Antique Brass
QG.700.07	Swivel**		Oil Rubbed Bronze
QG.700.02	Swivel**		Satin Nickel

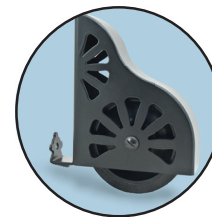

STANDARD  
WHEEL

\*Finish Pattern may vary

\*\*Patent Pending

### 1B 16" Ladder Hardware Kits with lower brake wheel

Part#	Description	Image	Finish
QG.210.08	Rolling		Black
QG.210.03*	Rolling		Hammered Antique Brass
QG.210.07	Rolling		Oil Rubbed Bronze
QG.210.02	Rolling		Satin Nickel
QG.510.08	Rolling Hook**		Black
QG.510.03*	Rolling Hook**		Hammered Antique Brass
QG.510.07	Rolling Hook**		Oil Rubbed Bronze
QG.510.02	Rolling Hook**		Satin Nickel
QG.710.08	Swivel**		Black
QG.710.03*	Swivel**		Hammered Antique Brass
QG.710.07	Swivel**		Oil Rubbed Bronze
QG.710.02	Swivel**		Satin Nickel

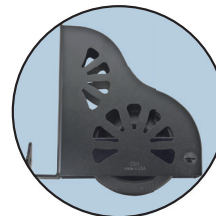

BRAKE  
WHEEL

Brake tension can be  
adjusted with allen  
wrench.

\*Finish Pattern may vary

\*\*Patent Pending

Spring loaded wheel locks when weight is applied on the ladder,  
wheel unlocks when weight is taken off.



MADE IN USA

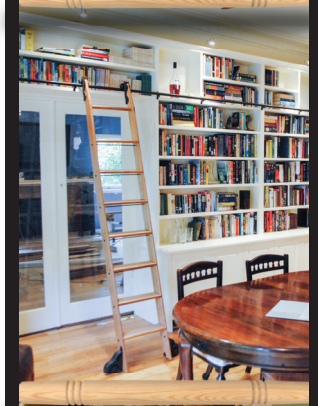
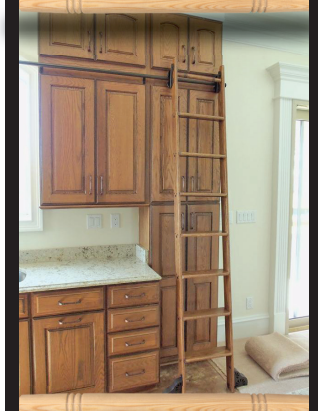



# Quiet Glide Rolling Ladders

## Standard 16" Wide ladder

### 1C 16" Ladder Hardware Kits with contemporary wheel

**In stock  
ready to ship**

Part#	Description	Finish
QG.220.08	Rolling	Black
QG.220.03*	Rolling	Hammered Antique Brass
QG.220.07	Rolling	Oil Rubbed Bronze
QG.220.02	Rolling	Satin Nickel
QG.520.08	Rolling Hook **	Black
QG.520.03*	Rolling Hook **	Hammered Antique Brass
QG.520.07	Rolling Hook **	Oil Rubbed Bronze
QG.520.02	Rolling Hook **	Satin Nickel
QG.720.08	Swivel**	Black
QG.720.03*	Swivel**	Hammered Antique Brass
QG.720.07	Swivel**	Oil Rubbed Bronze
QG.720.02	Swivel**	Satin Nickel

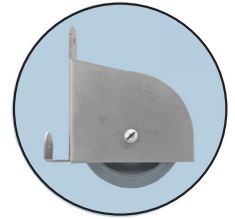

\* Finish Pattern may vary \*\*Patent Pending

CONTEMPORARY  
WHEEL

## 2 Select Rail Components

### 2A Determine how many feet (use splice kits to join rails, 2C)



**Rail - 1" diameter solid aluminum rail**

Part#	4ft Length
QG.4004.02	Satin Nickel
QG.4004.03*	Hammered Ant Brass
QG.4004.07	Oil Rubbed Bronze
QG.4004.08	Black

Part#	6ft Length
QG.4006.02	Satin Nickel
QG.4006.03	Hammered Ant Brass
QG.4006.07	Oil Rubbed Bronze
QG.4006.08	Black

Part#	8ft Length
QG.4008.02	Satin Nickel
QG.4008.03*	Hammered Ant Brass
QG.4008.07	Oil Rubbed Bronze
QG.4008.08	Black

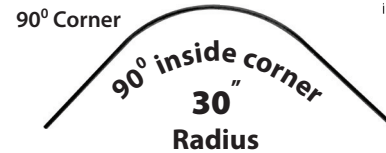

Part#	90° Inside Corner - 30" Radius - 5' length
QG.40CRV.08	Black
QG.40CRV.03*	Hammered Ant Brass
QG.40CRV.07	Oil Rubbed Bronze
QG.40CRV.02	Satin Nickel

\* Finish Pattern may vary

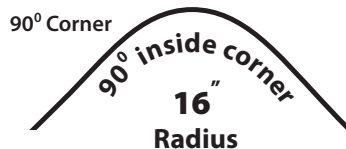

Part#	90° Inside Corner - 16" Radius - 5' length
QG.40CRV16.08	Black
QG.40CRV16.03*	Hammered Ant Brass
QG.40CRV16.07	Oil Rubbed Bronze
QG.40CRV16.02	Satin Nickel

Only used with swivel top hardware

\* Finish Pattern may vary

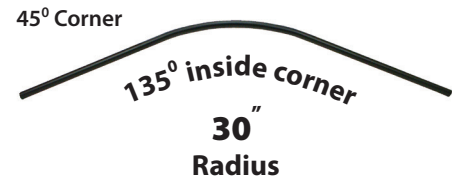

Part#	135° Inside Corner - 30" Radius - 5' length
QG.40CRV135.08	Black
QG.40CRV135.03*	Hammered Ant Brass
QG.40CRV135.07	Oil Rubbed Bronze
QG.40CRV135.02	Satin Nickel

Cannot be used with Rolling Hook top Hardware

\* Finish Pattern may vary



# Quiet Glide Rolling Ladders

## Standard 16" Wide ladder



### 2B Select how many Vertical or Horizontal Brackets

for your rail you will need

(choose correct bracket for Rolling, Swivel or Rolling Hook application)

You will need 1 bracket for every 32" or 4 brackets for an 8ft rail

#### Vertical Rail Bracket Kit

Part#	Description	Finish
QG.201.08	Rolling/ Swivel bracket	Black
QG.201.03*	Rolling/ Swivel bracket	Hammered Antique Brass
QG.201.07	Rolling/ Swivel bracket	Oil Rubbed Bronze
QG.201.02	Rolling/ Swivel bracket	Satin Nickel
QG.301.08	Rolling Hook	Black
QG.301.03*	Rolling Hook	Hammered Antique Brass
QG.301.07	Rolling Hook	Oil Rubbed Bronze
QG.301.02	Rolling Hook	Satin Nickel

\* Finish Pattern may vary



#### Horizontal Rail Bracket Kit

Part#	Description	Finish
QG.202.08	Rolling/ Swivel bracket	Black
QG.202.03*	Rolling/ Swivel bracket	Hammered Antique Brass
QG.202.07	Rolling/ Swivel bracket	Oil Rubbed Bronze
QG.202.02	Rolling/ Swivel bracket	Satin Nickel
QG.302.08	Rolling Hook	Black
QG.302.03*	Rolling Hook	Hammered Antique Brass
QG.302.07	Rolling Hook	Oil Rubbed Bronze
QG.302.02	Rolling Hook	Satin Nickel

\*Pattern may vary



### 2C Select how many Splice Kits you will need

(How many rails will you be joining together?)

Part#	Description
QG.41	Splice Kit for joining two rails



### 2D Select how many End Cap Kits you will need

\*2 End stops per kit

Part#	Description - End Cap Kit for Rails
QG.40.08	Black
QG.40.03*	Hammered Antique Brass
QG.40.07	Oil Rubbed Bronze
QG.40.02	Satin Nickel
QG.401.08	Black
QG.401.03*	Hammered Antique Brass
QG.401.07	Oil Rubbed Bronze
QG.401.02	Satin Nickel

\*Pattern may vary



### 2E Tap to thread rails for End Caps

Part#	Description
QG.TAP1420	1/4" x 20 Tap for rail

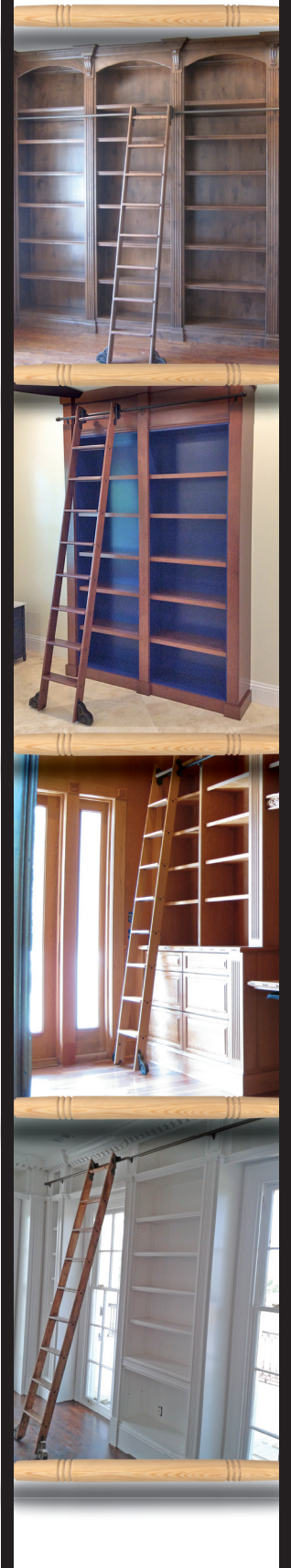



# Quiet Glide Rolling Ladders

## Standard 16" Wide ladder

### 3 Select the **wood ladder** and accessories

#### 3A **Ladder-in stock** (includes top turned rung) 16" wide ladders

Species	Part# 8ft	Part# 9ft	Part# 10ft
Red Oak	QG.6008.RO	QG.6009.RO	QG.6010.RO
Maple	QG.6008.MA	QG.6009.MA	QG.6010.MA
Cherry	QG.6008.CH	QG.6009.CH	QG.6010.CH
Walnut	QG.6008.WA	QG.6009.WA	QG.6010.WA

Sanded to 120 grit, flat cut, pre-drilled holes for fasteners, sides dadoed for steps, ready to finish & assemble.

**In stock**  
**ready to ship**



#### 3B **16" Custom Ladder**

Custom lengths and wood species available, 2-3 week lead time.

Plus Shipping includes top turned rung and supports.

Ladders above 8' require additional rung supports.

Species
Alder
Birch-White
Cherry
Hickory
Maple
Afr. Mahogany
Oak-Red
Oak-White Qrt Sawn
Walnut

#### 3C **Steam Bent Solid Wood Hand Rails** sold in pairs

Species	Part#
Cherry	QG.6309.CH
Hickory	QG.6309.HC
Maple	QG.6309.MA
Red Oak	QG.6309.RO
Walnut	QG.6309.WA

Sanded to 120 grit with predrilled assembly holes. Specify black or nickel fasteners (included)

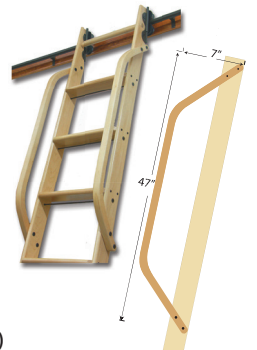

#### 3D **Additional Step Supports** for 9' and 10' ladders

\* For ladders over 8' or if you build your own ladder. For 16" wide ladders, for 9' and 10' ladders or build your own ladders.

Part#	Description
QG.620.08	Extra Step Support- Black
QG.620.02	Extra Step Support- Satin Nickel



#### 3E **Top turned Rungs** when building your own ladder. \* Included with in stock ladders



Species	Part#	Species	Part#	Species	Part#
Red Oak	QG.610.RO	Walnut	QG.610.WA	Mahogany	QG.610.MG
Maple	QG.610.MA	Pine	QG.610.PN	Alder	QG.610.AD
Cherry	QG.610.CH	Hickory	QG.610.HC	Ash	QG.610.AS

#### 3F **Non - Skid Step Tread** Transparent

QG.61 Clear





**Please Note!!**

### Tools Required For Assembly

- 4mm & 5mm allen wrenches.
- #2 Phillips & #2 Square screw driver.
- 1/4" x 20 thread tap.
- 1/4" Drill bit

## Step 1: Rail Installation

(A) Slide brackets into rail, recommended maximum spacing 32 inches apart. Pre-drill holes in wood if needed and screw brackets in place.

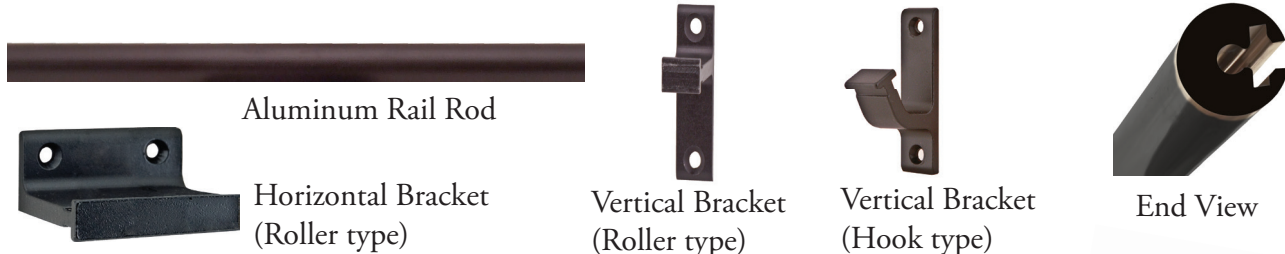

(B) Use the splice kit to connect rails together. (If applicable) Insert roll pin halfway into one of the rails. Slide the steel bar half-way into rail. Secure the splice kit to rail on both sides by tightening the set screws.

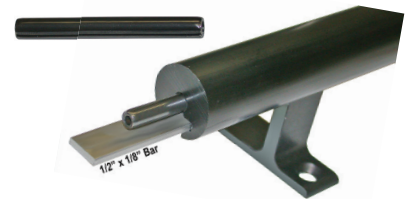

(C) Tap the end of the rail with a 1/4" x 20 tap (not supplied) to screw in the end stop finial (done before installation of rail). Install end cap with screw provided using a 4mm Allen wrench.

**Note:** Leave at least a **7 inch clearance** above the rail for the top guide hardware to operate properly, and allow the ladder to move against the wall for storage.



## Step 2: Ladder Assembly (if applicable)

Assemble the steps onto the side rails with glue and screws. Glue and pin nail the top turned rung into place.

## Step 3: Ladder Hardware Installation

(A) Install steps support rods under each step using 5mm allen

(B) Drill holes and install top guides to ladder centering the top dowel (top dowel recommended) of the ladder. The placement of the holes will allow a small adjustment of height of ladder, either up or down.



Install Top Turned Rungs

Use a forstner bit, drill 7/8" hole part way through for the turned rungs

### Top Turned Rung

15-3/8" long x 1-1/4"Dia., 7/8" Dia. ends.  
14-3/8" Inside Width Unfinished



(C) Line up bottom rollers vertical to the floor when ladder is in the climbing position Pre-drill holes and install bottom rollers.



Note: Proper Pre-drilling of holes for the wood screws on the bottom of the ladder will prevent splitting of the ladder side rails

# Top Ladder Hardware

**Patent Pending -  
on Rolling Hook Top Hardware**

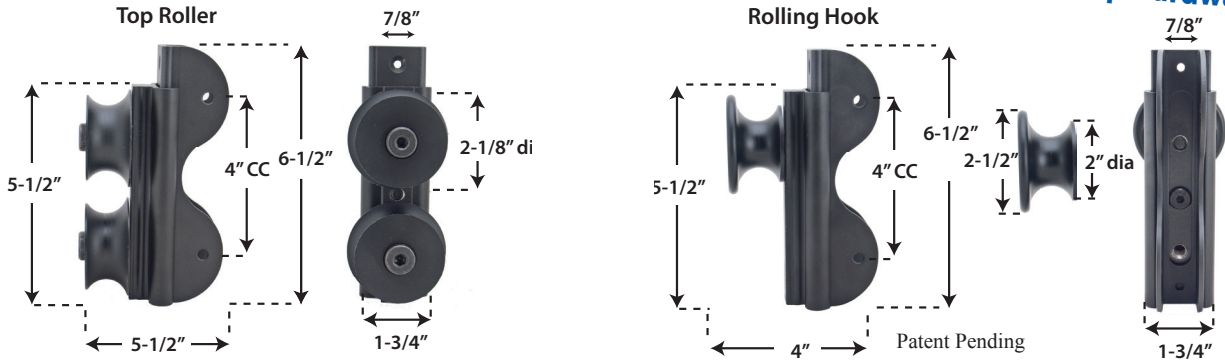

# Bottom Ladder Hardware

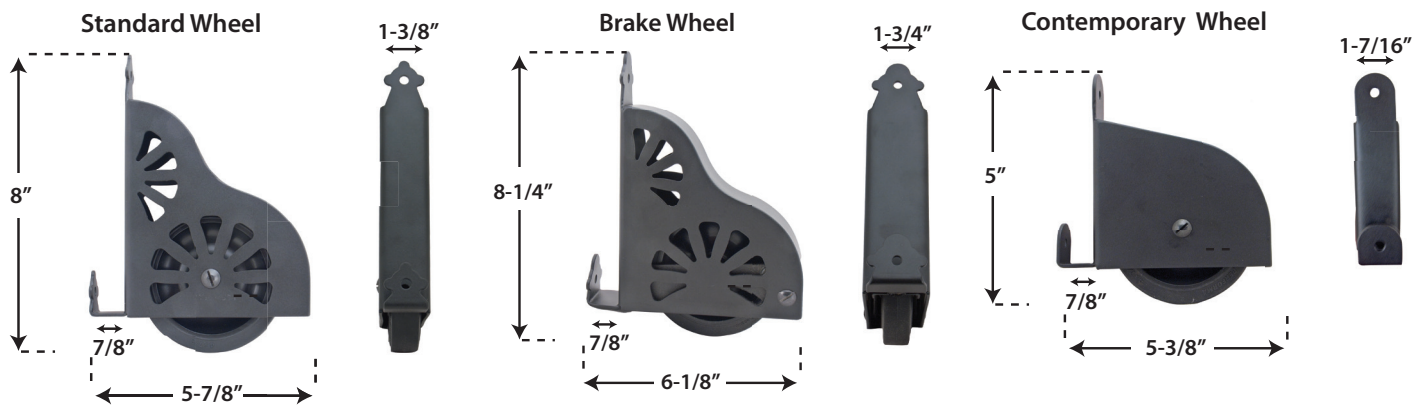

# Rail Height and distance for 8', 9', 10' standard ladders

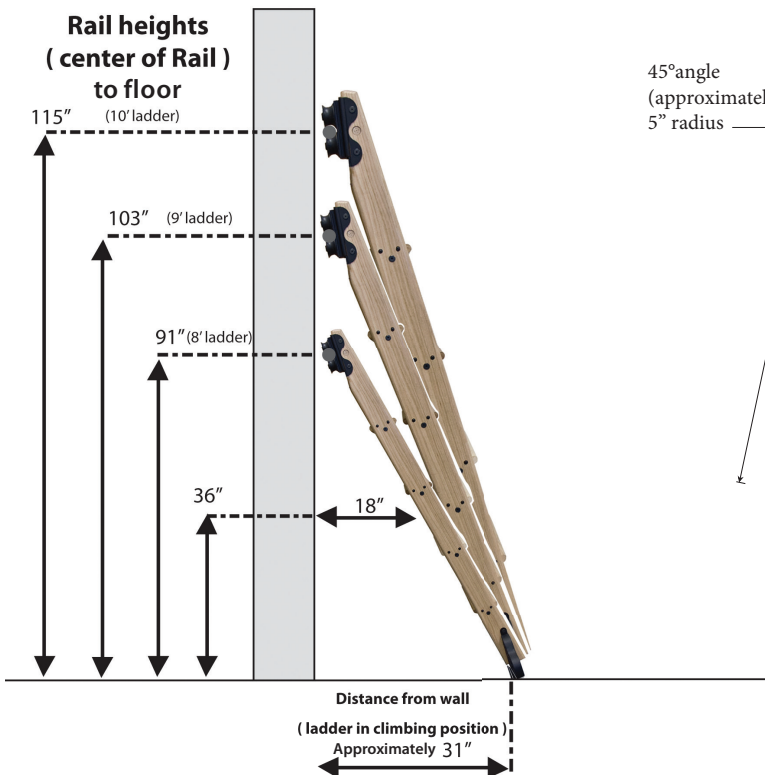

# Hand Rail dimensions

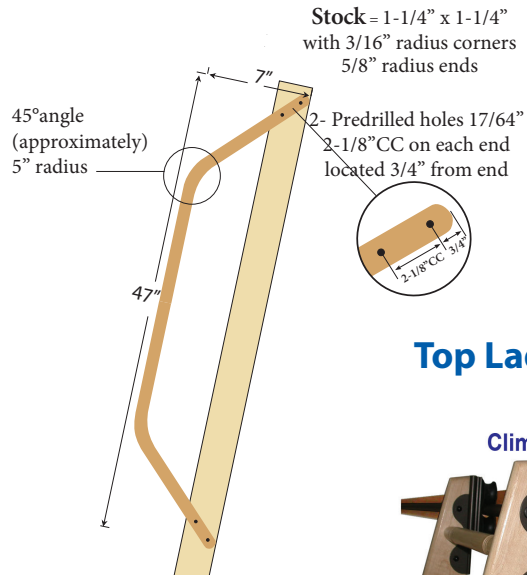

# Top Ladder Clearance

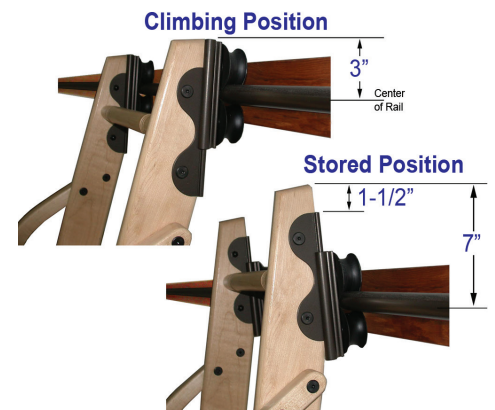



# Curved rail radius dimensions

Hook top Hardware cannot be used with curved rails!



MADE IN USA

Rail Diameter = 1"

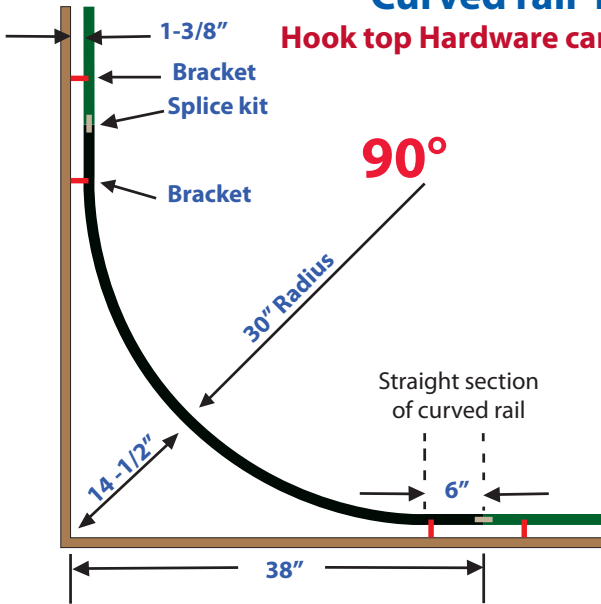

## Rail Bracket - Vertical Roller type

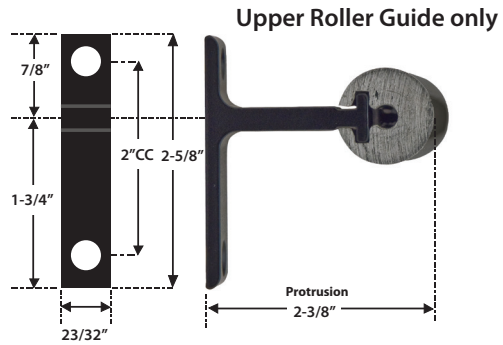

## Rail Bracket - Vertical Hook or Rolling Hook type

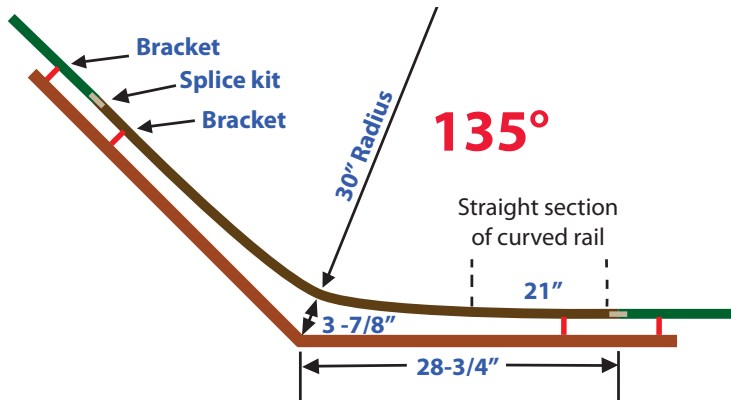
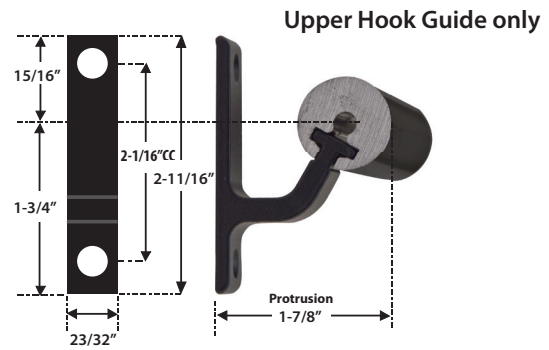

## Rail Bracket - Horizontal Rolling Hook type

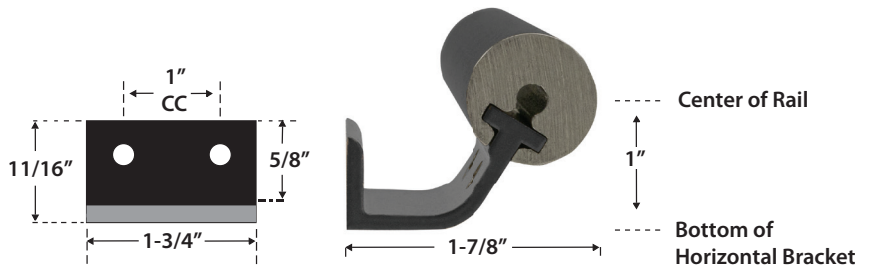

## Rail Bracket Horizontal Roller type

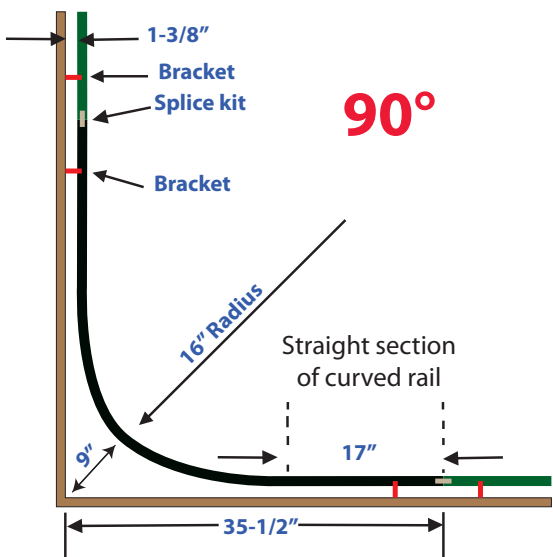
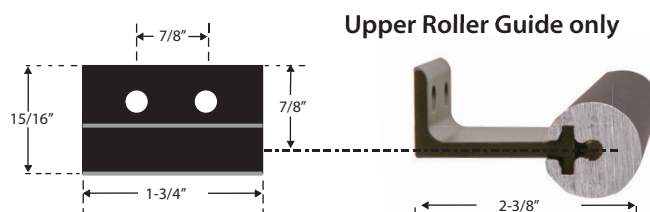

# Make your own Ladder

To determine length of ladder: Measure from the center of rail to the floor, then **add five inches** to the measurement.

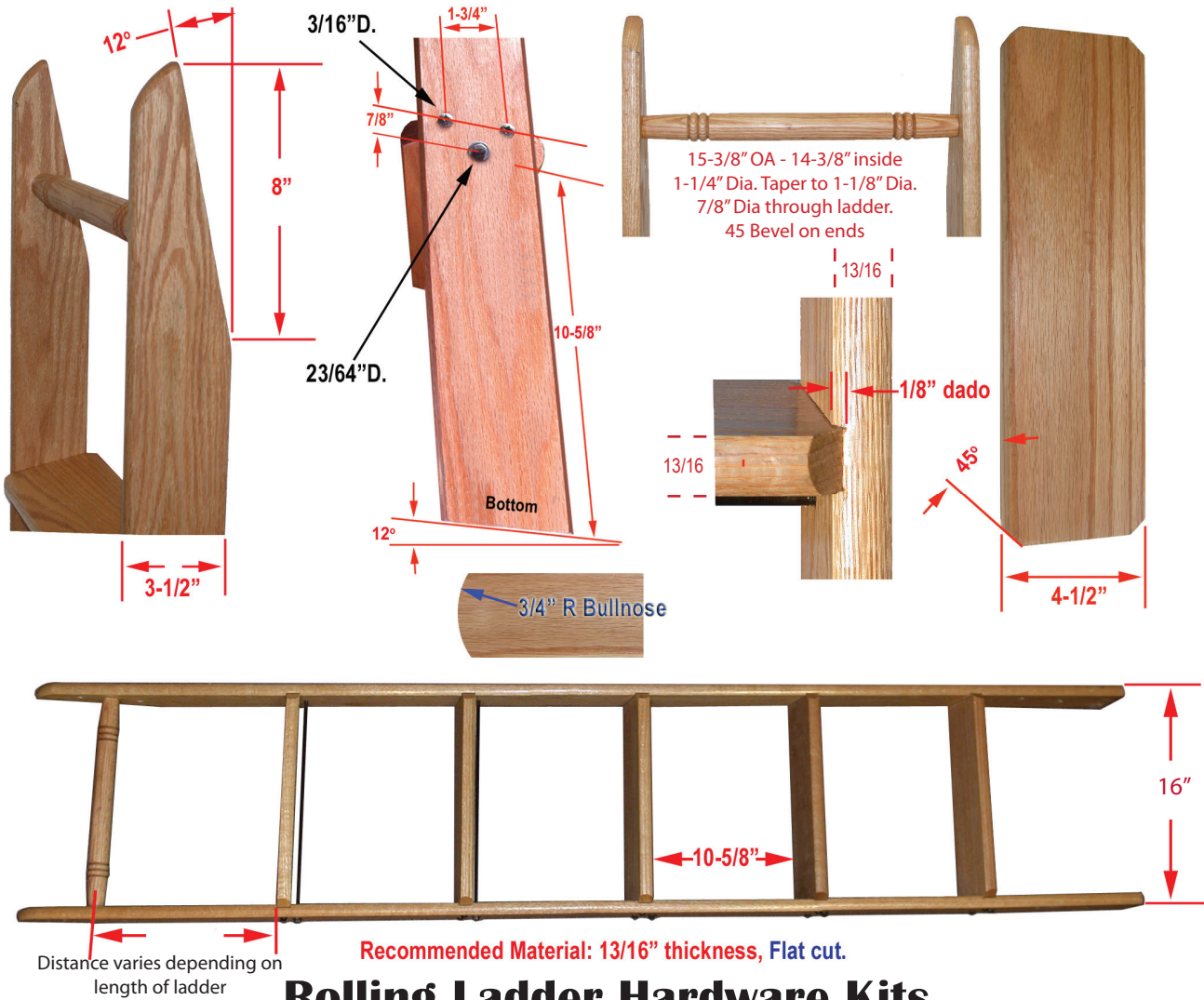

## Rolling Ladder Hardware Kits

Patent Pending - Exclusive Patent on Rolling Hook Top Hardware

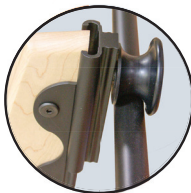

Rolling Hook upper guide

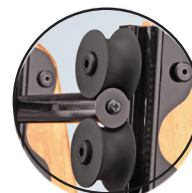

Roller upper guide

LIFETIME WARRANTY

