

HOME DECORATORS COLLECTION

DECORATIVE SHADE FOR RECESSED LIGHT

Assembly Instructions

HDC#: 0597600410 MFG#: CSN-0303-1

Please read over the instructions, it will be a time-saver in the long run.



Questions?

Call customer service at 1-866-384-9400, 10 a.m. - 5 p.m.,
EST, Monday - Thursday, 10 a.m. - 4 p.m., EST, Friday.

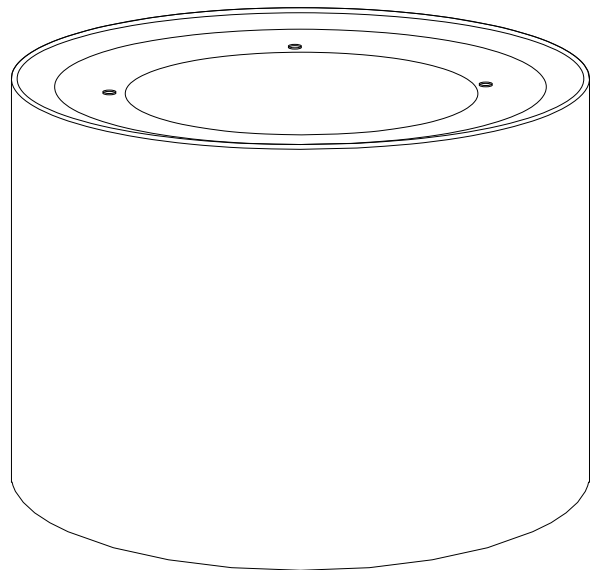

ATTACH YOUR RECEIPT HERE

Serial Number _____

Purchase Date _____

PACKAGE CONTENTS

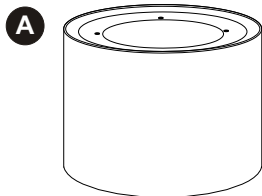

x 1
Shade

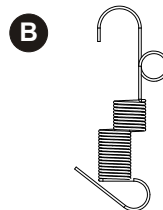

x 4
Spring Hooks

SAFETY INFORMATION

Please read and understand this entire manual before attempting to assemble, operate or install the product.

CAUTION

- Turn light switch off prior to mounting.

PREPARATION

Before beginning installation of product, make sure all parts are present. Compare parts with package contents list and hardware contents list. If any part is missing or damaged, do not attempt to assemble, install or operate the product.

Estimated Assembly Time: 5-10 minutes.

Helpful Tools (not included): Spring hook mounting tool.

ASSEMBLY INSTRUCTIONS

1. Remove existing fixture trim and bulb.

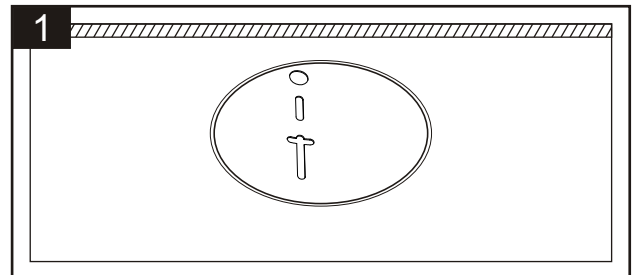

2. Attach spring hooks (B) to shade (A).

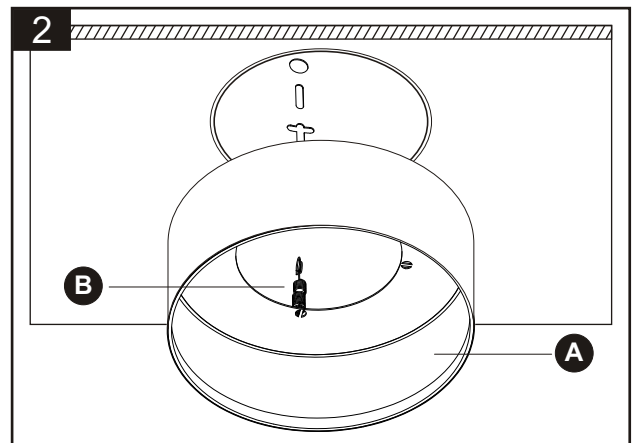

3. Attach spring hook (B) to holes in recessed fixture.
NOTE: Position shade tight against the ceiling to prevent light from emitting at the top, if so desired.

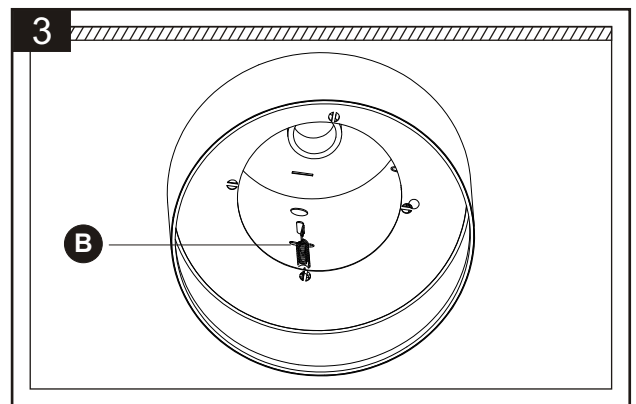

CARE AND MAINTENANCE

- Clean fabric with damp cloth.

TROUBLESHOOTING

PROBLEM	POSSIBLE CAUSE	CORRECTIVE ACTION
Shade hangs unevenly.	Spring hooks not positioned properly.	Re-position spring hooks as needed.
No pre-existing holes or slits in recessed light fixture to attach spring hooks.	Certain recessed light fixtures have no holes or slits.	Attach spring hooks to V-clips (not included) inside of recessed light fixture.

WARRANTY

The manufacturer warrants against defects in materials and workmanship for one (1) year from the date of purchase to the original purchaser. If within this period the product is found to be defective, take a copy of the bill of sale as a proof of purchase and the product in its original packaging to the place of purchase. This warranty does not cover products becoming damaged or defective caused by abuse, misuse, accidents, faulty installation, improper handling and/or maintenance, or repairs not carried out by the manufacturer. Items which are not covered by warranty are those considered as parts which are prone to failure due to general wear and tear (or example, lamps, fuses, glass materials). There will be no obligations or liability on the part of the manufacturer for consequential damages arising from the use of the product or any indirect damages with respect to loss of property, revenue, or costs for removal, installation or re-installation. As some states do not allow exclusions of limitations on an implied warranty, the above exclusions and limitations may not apply. This warranty gives you specific rights and you may also have other rights which may vary from state to state.

REPLACEMENT PARTS LIST

For replacement parts, call customer service 1-866-384-9400, 10 a.m. - 5 p.m., EST, Monday - Thursday, 10 a.m. - 4 p.m., EST, Friday.

PART	DESCRIPTION	PART #
B	Spring Hooks	Sp1