

DURABENCH | 4 IN 1 MULTIPURPOSE WORKBENCH

Model Number: DURA4IN1

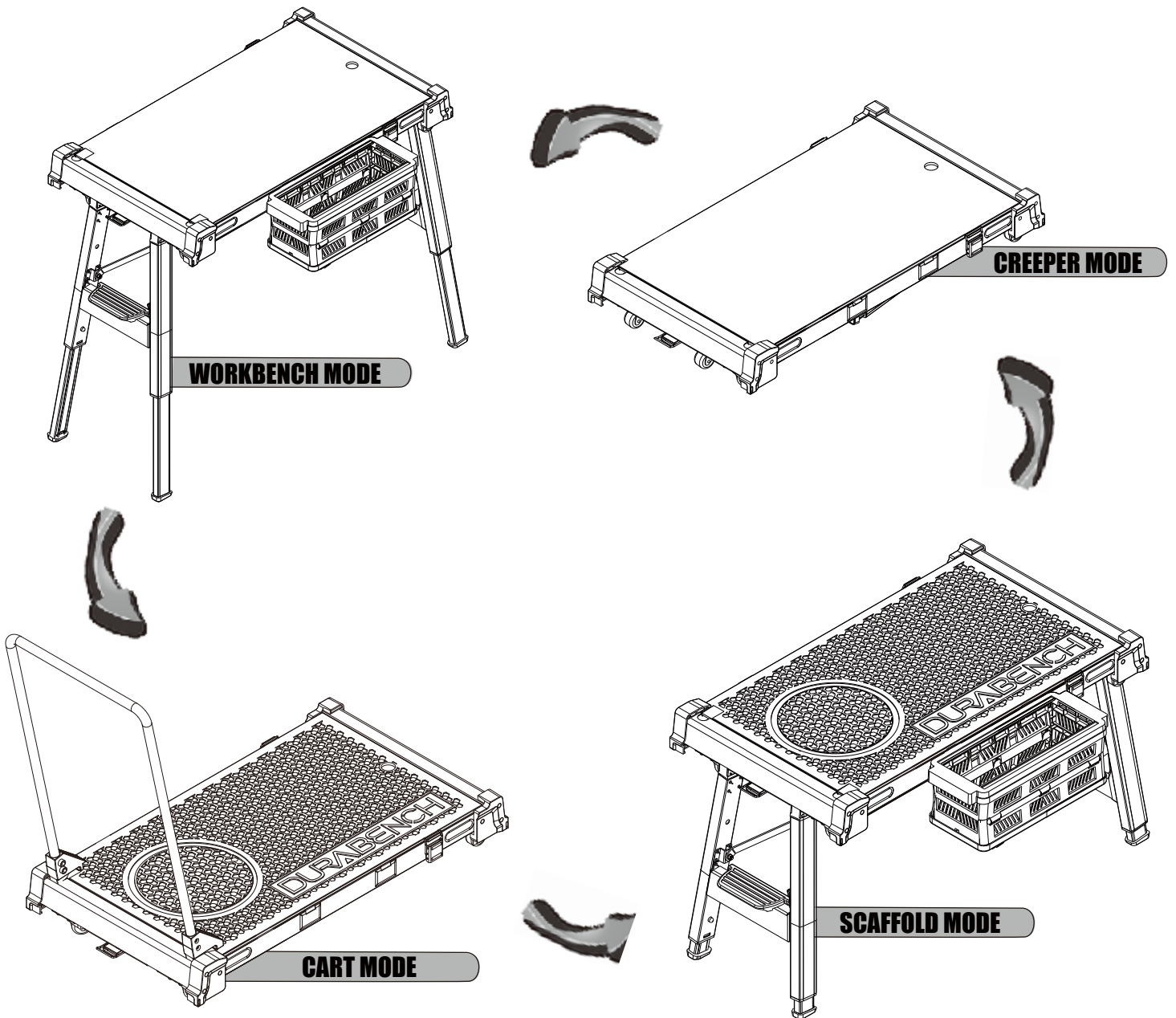

INSTRUCTION MANUAL

IMPORTANT SAFETY INSTRUCTIONS

TO REDUCE THE RISK OF INJURY, PLEASE READ AND UNDERSTAND ALL INSTRUCTIONS BEFORE USING THIS PRODUCT. FAILURE TO FOLLOW ALL INSTRUCTIONS BELOW MAY RESULT IN SERIOUS PERSONAL INJURY.

SAVE THIS MANUAL FOR FUTURE REFERENCE.

GENERAL SAFETY INSTRUCTIONS

ELECTRICAL SHOCK HAZARD: This product has an electrical socket on one side which requires plug for electric supply. Incorrect connection may cause electrical shock, which may result in injury or death.

ELECTRICAL SHOCK RISK: Do not connect to electricity if there is a water, including in humid weather, or placed near a water pipe.

POWER REQUIREMENTS: 120V AC, 15 amp Max, 12 AWG Cord Only.

When not use this product, do not store this product in a humid place to avoid damaging product.

When using this product in the scaffold mode, keep your feet firmly planted in the center of the scaffold. Do not step on the four corners of the product surface as this may cause the product to tip over and result in personal injury.

When using this product in the scaffold or workbench modes, place objects in the center of the product's surface. Placing objects on the corners may cause the product to tip over. Only workbench and scaffold mode can hang the basket.

When using this product in the creeper or cart modes, do not step or stand on this product, as this may cause personal injury.

When extending or retracting the legs, do not use excessive force as this may damage the product.

Before using this products, make sure that the legs are firmly locked in position and latches are closed tightly over the top panel.

Please follow the instruction, and do not use this products for any other purpose.

When using this product with power tools, referring to the manufacturer's instructions for properly using electric tools. Always wear safety goggles.

WEIGHT CAPACITIES

Do not exceed the following weight capacities:

MODE	WEIGHT CAPACITIES
Workbench	500 lbs
Scaffold	500 lbs
Cart	300 lbs
Creeper	265 lbs

WORKBENCH MODE

Electrical sockets are placed on one side of the product. Connect an external power source to the socket using a 2-pronged and 2 USB port extension cord. You can connect up to 2 power tools to the power strip simultaneously. You can write and draw on work surface and store your working accessory in 2 trays under the panel.

2 trays under the panel

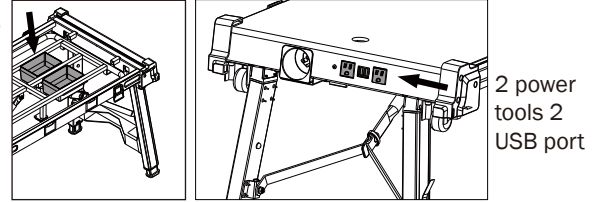

If needed, tool basket can hang on the hole of long side.

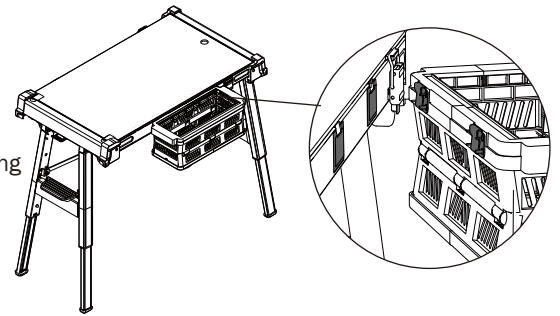

SCAFFOLD MODE

Place bucket into the circle of the left side of the scaffold surface. Stand in the center of the scaffold surface. Do not stand or step on the location marked with X's in the figure to the right as this may cause the product to tip over and result in personal injury.

CAUTION: Work scaffold mode only has 500lbs weight capacity. DON'T use scaffold with legs fully extended. This will cause serious injury.

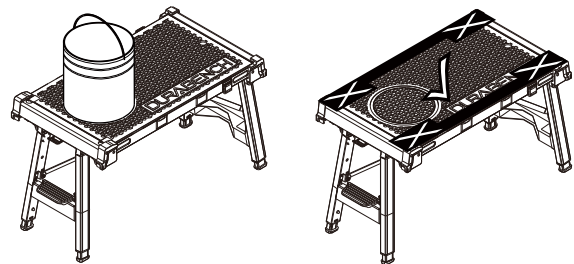

CART MODE

Put object in the center of the work surface. Be aware of the object fall off.

CAUTION: Before using cart mode, please remove the basket. DON'T exceed over 300lbs weight capacity. Do not step or stand on the work surface in cart mode.

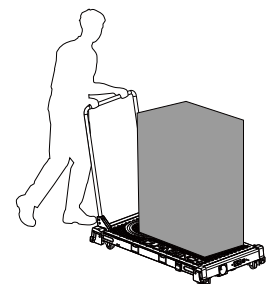

CREEPER MODE

Use this mode to perform job in low spaces. Also put the product into this mode when storing or moving. A carrying handle is provided.

CAUTION: Before using creeper mode, please remove the basket. Do not step or stand on the work surface in creeper mode.

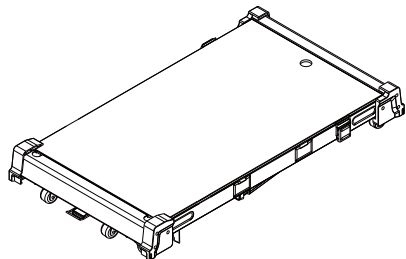

CHANGING MODES

CREEPER MODE TO WORKBENCH MODE

a. Turn the product over, release the lock from the narrower set of legs

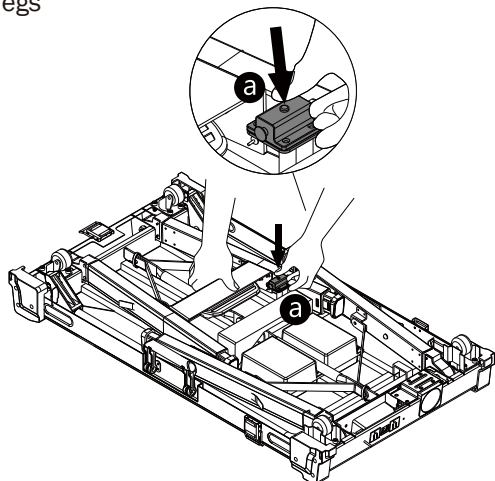

- b. Turn the narrower legs outward.
- c. Then open the wider set of legs and turn the wider legs outward.
- d. Push the Y-type brace until it locks.
- e. Fold the side-step into the horizontal position on the side.

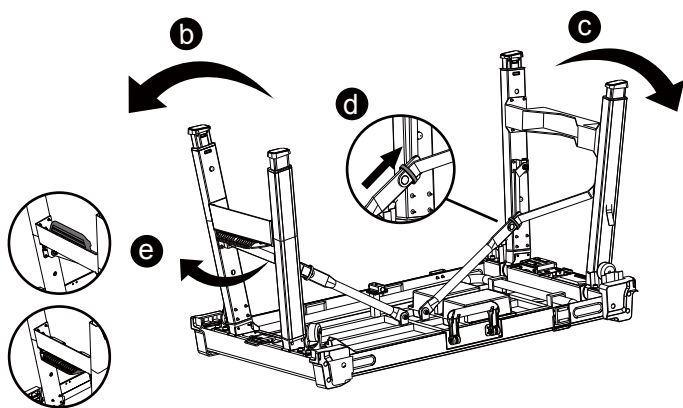

NOTE: You must open the narrower set of legs first, then the wider set of legs. Otherwise the legs can not open.

e. Lay the product down on the floor, press each pin on legs and pull legs out until the pin clicks.

CAUTION: Make sure the pin on each leg clicks out before using the products. Failure to do this may lead to the legs retracting while using.

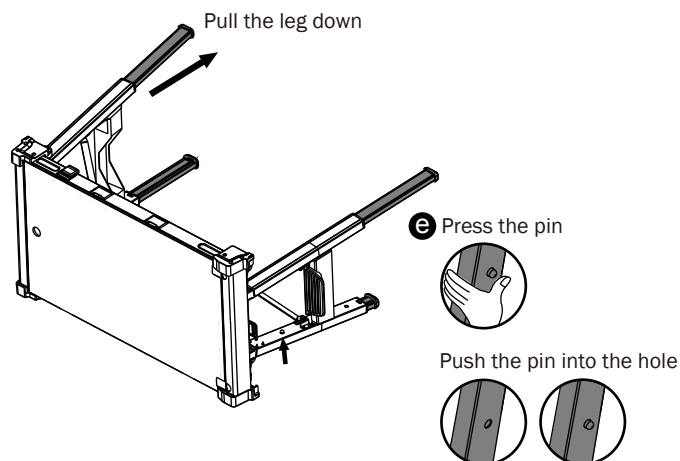

WORKBENCH MODE TO SCAFFOLD MODE

a. Lay the product down on the floor, press the pin on each leg and push each leg in until the pin clicks into place on the upper holes.

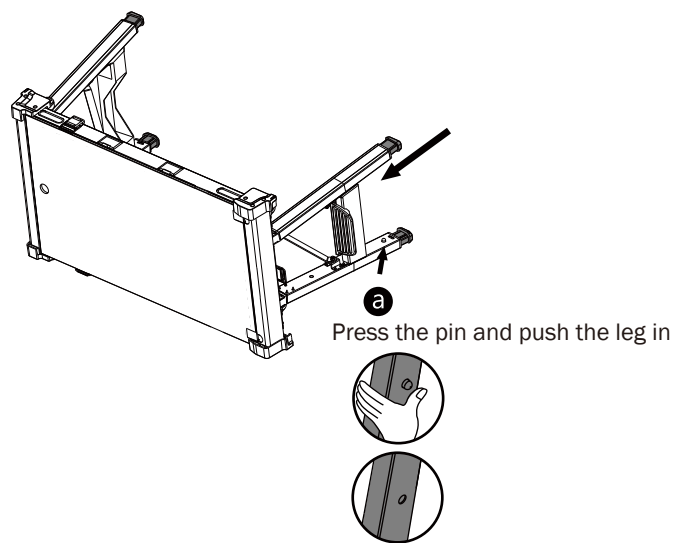

b. Stand the product up and open the two latches on the two longer sides.

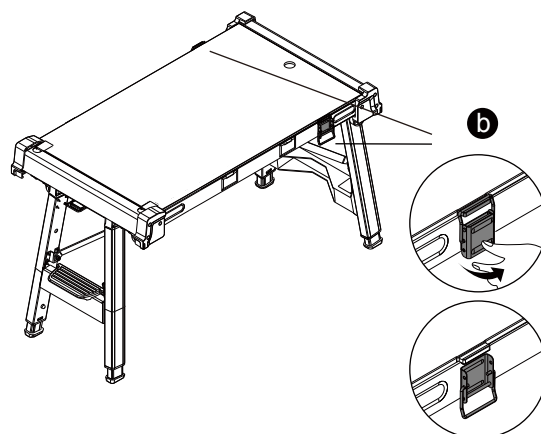

c. Remove the panel, turn it over so that the anti-slip work surface is face up, and place it back onto the scaffold. Fasten the two latches.

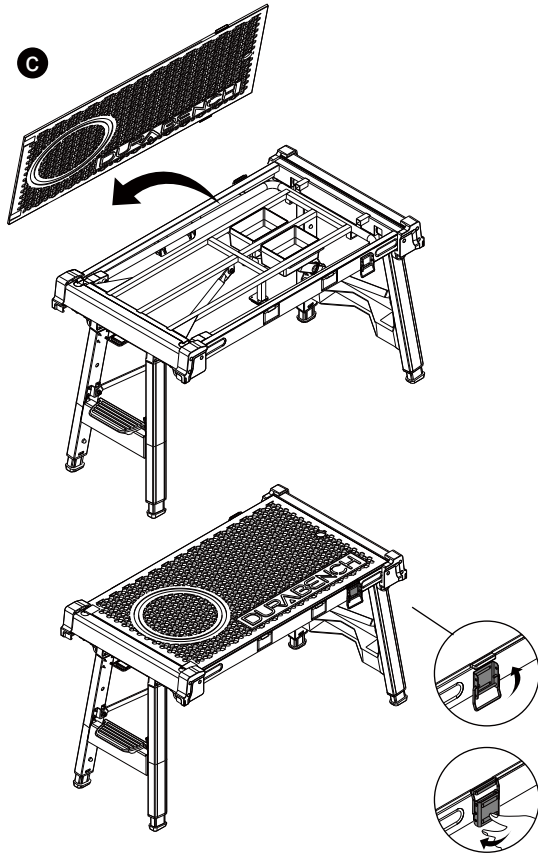

d. Turn the product over so the wheels are on the floor, open the latches, remove the panel and turn it over to the smooth surface, then fasten the latches.

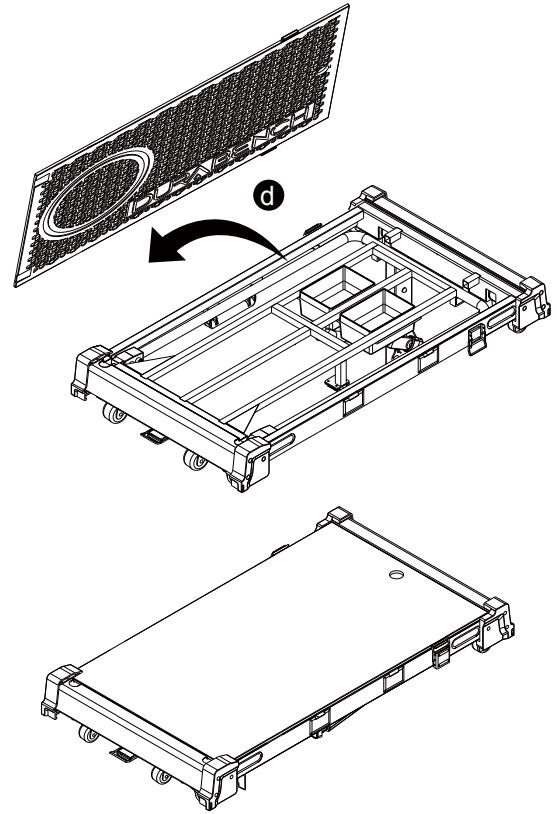

SCAFFOLD MODE TO CREEPER MODE

a. Turn the product over and flip down the step on the side.

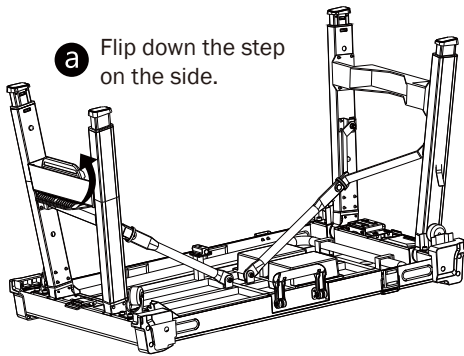

b. Press the wider Y-type brace and push the wider legs inward until they are locked in place.
 c. Repeat this procedure for the narrower Y-type brace and narrower legs.

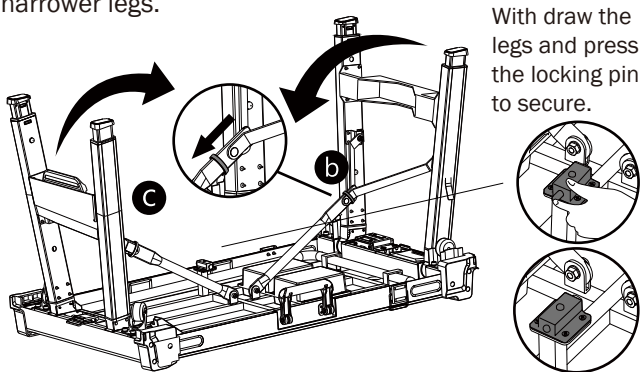

NOTE: You must close the wider set of legs first, then the narrower set of legs. Otherwise the legs will not close properly.

CREEPER MODE TO CART MODE

a. Open the two latches, pull out the panel and pull up the handle.

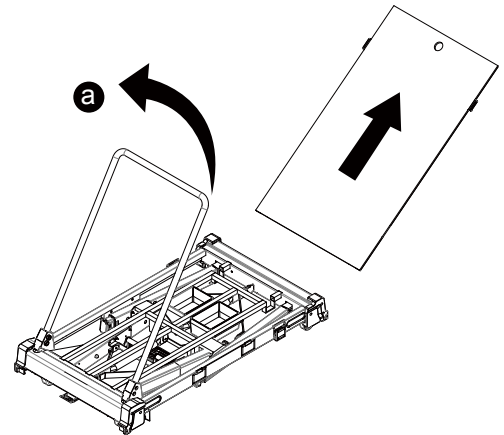

b. Turn over the panel to anti-slip work surface. Slip the panel into the corner protectors fasten the latches.

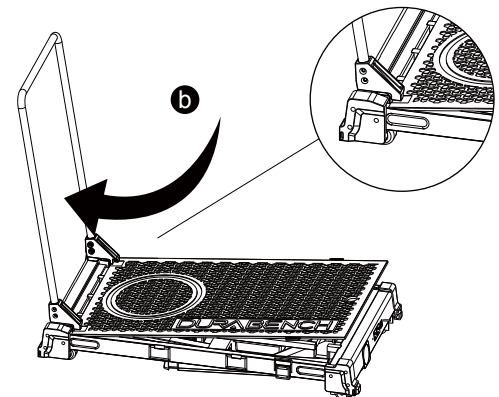

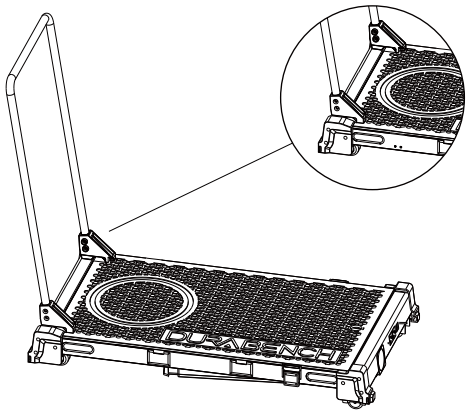

NOTE: Before using this product in cart mode, make sure that the handle are firmly locked in position and latches are closed tightly over the top panel.

SCARFFOLD CONNECTING

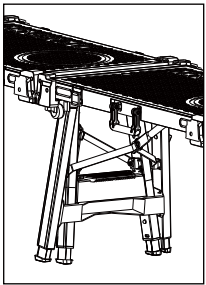

Put two Durabenches side by side, the narrower set of legs into the wider set of legs. A latch under the side of power strip can lock two Durabenches together.

CAUTION: Connecting work scaffold **MUST** be on the flat floor to avoid people serious injury. Lock latch when you connect two Durabenches.

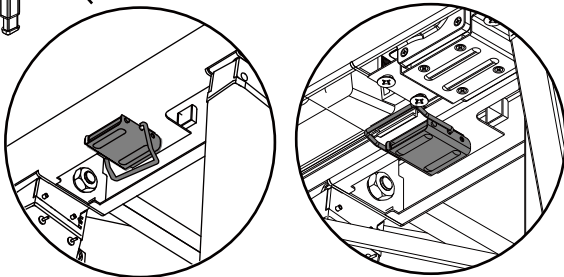
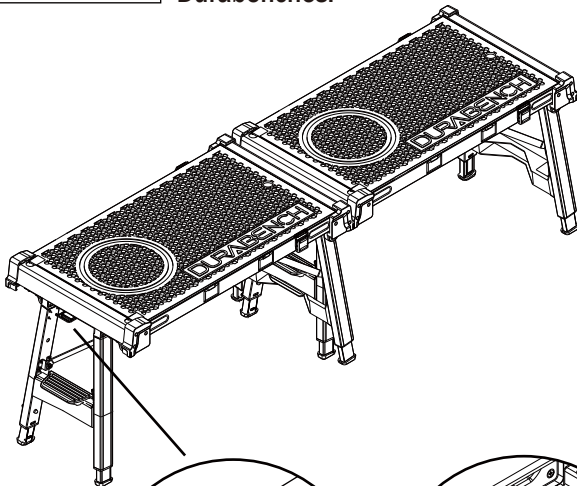

Make sure the lock is locked on.

LIMITED WARRANTY

Valore ("Seller") and the person or entity that acquires these goods from Seller ("Purchaser") hereby fully agrees to the following terms and conditions of the sale: Shipping fees are the responsibility of the Purchaser whether freight prepaid or freight collect. Seller assumes no responsibility for the goods sold to the Purchaser once the goods have left the Seller's premises, including but not limited to, late delivery by the moving carrier, or for events caused by any difficulty carrier incurs in attempting to fit the goods into the Purchaser's place of business or residence due to size of the goods or otherwise Purchaser assumes all responsibility for delivery, payment of freight, access, measurement, installation, hook-up, wiring, moving and storage of the goods. The transportation of all goods is subject to the terms and conditions which the moving carrier imposes on Purchaser including, but not limited to, additional charges imposed per flight of stairs, and/or additional charges resulting from the carrier's inability to safely and/or adequately use the building elevator to lift the goods to an upper level. Any claim for damages incurred during the shipment by the carrier of the goods are insured and handled directly with the carrier. Any damages due to manufacture defects will be handled directly with Valore, subject to the limited warranty.

All sales are final, and unless authorized in writing by the Seller, Purchaser may not return the goods, under any circumstance. If Purchaser refuses to accept the goods, under any circumstance, the Purchaser is liable for the return and cost of freight both ways, and if seller does take the goods, there may be a restocking fee that of 20% of the purchase price of the goods in addition to the freight. Purchaser must notify Seller of non-conforming goods within seven (7) days of delivery, after which time all goods are deemed accepted. If an order has been placed and production started, cancellation cost of your order will be 20% or the purchase price.

The limited warranty does not cover damage due to such things as accident, misuse, abuse, mishandling, neglect, acts of God, fires, earthquakes, floods, high winds, government, war, riot or labor issues defined as strikes, lockouts, delay of carrier, unauthorized repair, or any other beyond the control of the Seller whether similar or dissimilar to the foregoing. Seller is not responsible for any damages caused by the Purchaser misusing, mishandling or abusing the intended the use of the goods. Limited warranty applies only inside the Continental U.S. or Canada (Alaska, Puerto Rico Hawaii, Yukon, Northwest Territories, and Nunavut not included). The limited warranty is not transferrable between the US and Canada.

The limited warranty is only valid with the provision of proof-of-purchase from an authorized retailer of Valore branded products.

Seller is not responsible for labor expenses that are incurred due to service or installation charges.

Seller is not responsible for incidental or consequential damages and there are no warranties, expressed or implied, which extend beyond the limited warranty described above. The implied warranties of merchantability and of fitness for a particular purpose are hereby expressly disclaimed. Some states do not allow the exclusion of incidental or consequential damages, or a waiver of the implied warranties of fitness and/or merchantability, so the above limitations may not apply to you. This warranty gives you specific legal rights and you may have other rights, which vary from state to state.

LENGTH WARRANTY

Warranty period: 1 year from the purchase date with valid receipt .

Conditions: We provide repair service free of charge but such service will be limited to products defect only. Any damage caused by misuse of users shall not be covered by the warranty hereof.

This warranty does not apply to products that have been misused, abused, damaged by accident or otherwise, subjects to abnormal use or modified. If this product is defective, please contact us info@valoreusa.com

**BEFORE RETURNING THIS PRODUCT
FOR ANY REASON PLEASE CALL 877-511-0484 OR E-MAIL US AT INFO@VALOREUSA.COM**

Please leave a detailed message with your contact information. We will reply within 48 hours. If you have any (comments or) suggestions, please contact us. Your feedback is valuable and vital to Durabench.