

18" Panel Ready Special Application

800 Series – Panel Ready SPV68U53UC



SPV68U53UC
Panel Ready

The 3rd rack offers 30% more loading area. Perfect for ramekins, cooking utensils and extra long silverware.

Features & Benefits

44 dBA: Quietest dishwasher brand.

3rd rack adds versatility and offers 30% more loading area.**

Water softener ensures optimally spot-free and shiny dishes.

RackMatic® offers 3 height levels, for 9 possible rack positions.

InfoLight® shines on the floor so you know the dishwasher's running.

General Properties

Number of wash cycles	6
Number of options	5
dBA	44
Third rack	Standard
Rack adjustability	RackMatic®
Tub material	Stainless steel
Control type	Buttons
Concealed heating element	Yes
Leak protection system	24/7 AquaStop® Plus
Water softener	Yes
Five-level wash	Yes
ChildLock	No
Special features	InfoLight®, Eco Cycle

Efficiency

Water usage per cycle	3.0
Energy efficiency class	Tier 1
ENERGY STAR® qualified	Yes
Total annual energy consumption (kWh)	259 kWh
Total annual water consumption (g)	645

Capacity

Number of place settings	10
--------------------------	----



Technical Details

Watts (W)	1440 W
Current (A)	12 Amps
Volts (V)	120 V
Frequency (Hz)	60 Hz
Power cord length	68 7/8"
Minimum water pressure (lb/sin)	7
Length inlet hose (in)	65"
Length outlet hose (in)	80 5/8"

Dimensions & Weight

Overall appliance dimensions (HxWxD) (in)	32 1/16" x 17 5/8" x 21 5/8"
Required cutout size (HxWxD) (in)	32 1/8" x 17 3/4" x 22 7/16"
Adjustable feet	Yes
Net weight (lbs)	75 lbs

Accessories—Optional

Dishwasher Softener Salt (4.4 lbs)	SGZ9092UC
Dishwasher Drain Hose Extension 76 3/4"	SGZ1010UC
Dishwasher Accessory Kit	SMZ5000
Hinge for 4" Toekick Height Installation	SMZ5003



**Compared to Bosch dishwasher with two racks.

Accessories: To purchase Bosch accessories, cleaners & parts please visit www.bosch-home.com/us/store or call 1-800-944-2904 (Mon to Fri 5 am to 6 pm PST, Sat 6 am to 3 pm PST).

Notes: All height, width and depth dimensions are shown in inches. BSH reserves the absolute and unrestricted right to change product materials and specifications, at any time, without notice. Consult the product's installation instructions for final dimensional data and other details prior to making cutout.

Warranties: Please see Use & Care manual or Bosch website for statement of limited warranty.

For more information on our entire line of products, go to www.bosch-home.com/us or call 1-800-944-2904

© BSH Home Appliances Corporation. All rights reserved. Bosch is a registered trademark of Robert Bosch GmbH.

18" Panel Ready Special Application

800 Series – Panel Ready SPV68U53UC



BOSCH

Invented for life

Installation Details

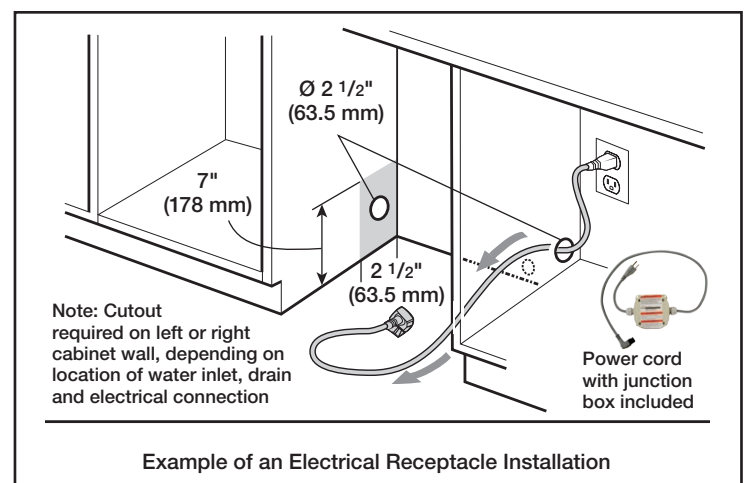
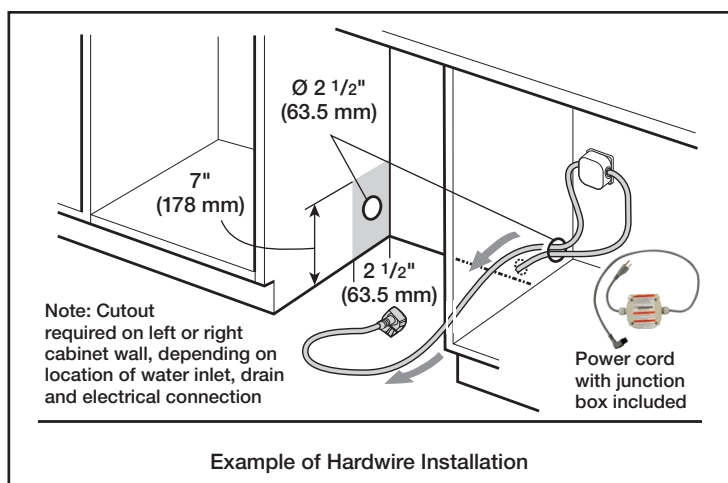
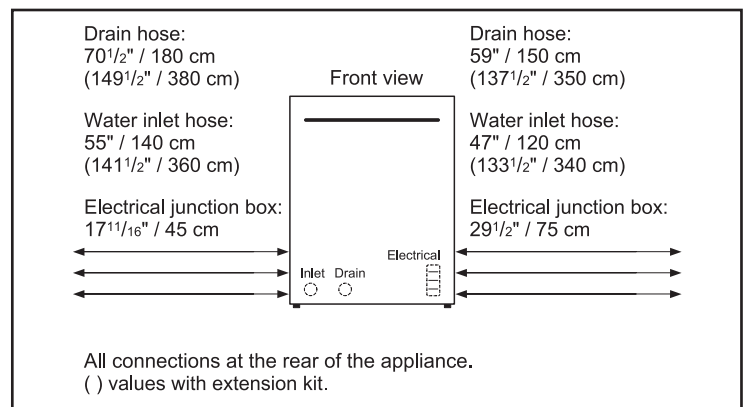
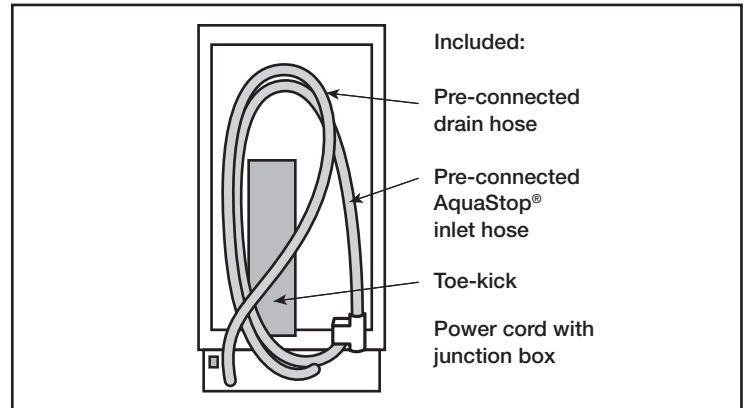
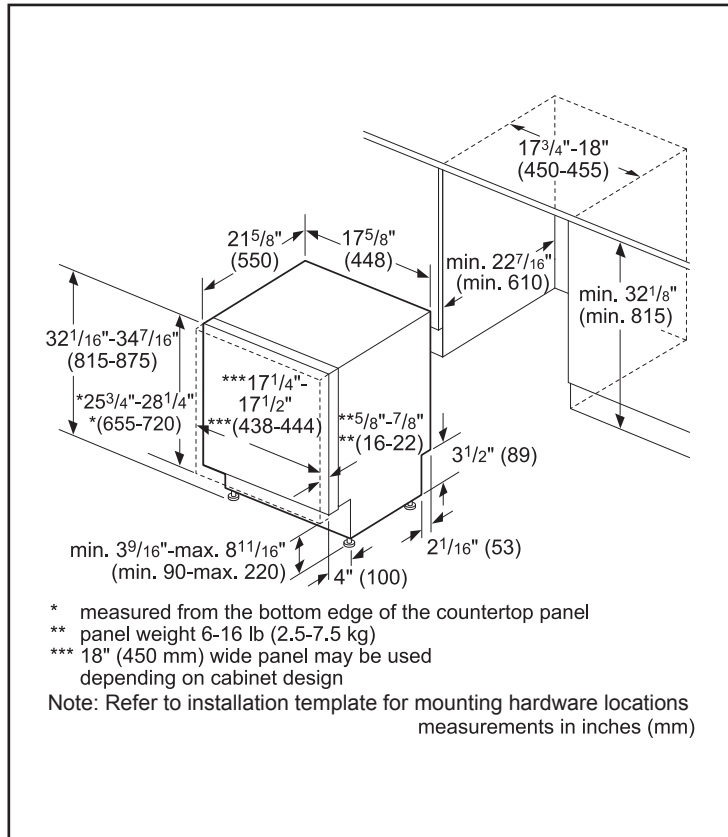

Accessories: To purchase Bosch accessories, cleaners & parts please visit www.bosch-home.com/us/store or call 1-800-944-2904 (Mon to Fri 5 am to 6 pm PST, Sat 6 am to 3 pm PST).

Notes: All height, width and depth dimensions are shown in inches. BSH reserves the absolute and unrestricted right to change product materials and specifications, at any time, without notice. Consult the product's installation instructions for final dimensional data and other details prior to making cutout.

Warranties: Please see Use & Care manual or Bosch website for statement of limited warranty.

For more information on our entire line of products, go to www.bosch-home.com/us or call 1-800-944-2904

© BSH Home Appliances Corporation. All rights reserved. Bosch is a registered trademark of Robert Bosch GmbH.

18" Panel Ready Special Application

800 Series – Panel Ready SPV68U53UC



BOSCH

Invented for life

Installation Details

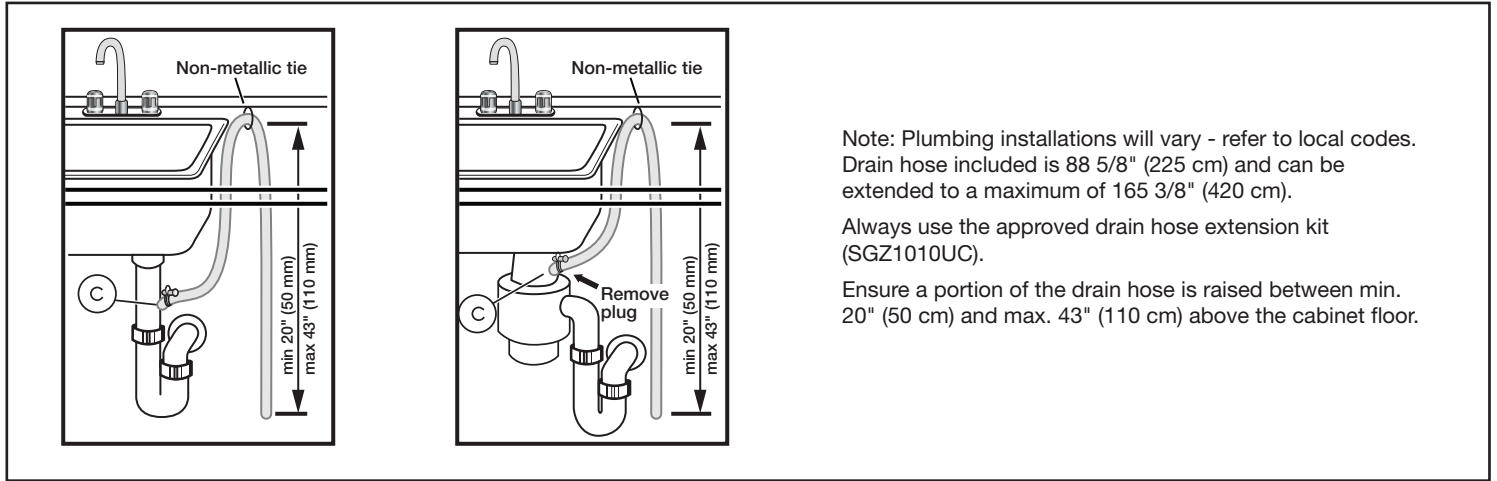

Accessories: To purchase Bosch accessories, cleaners & parts please visit www.bosch-home.com/us/store or call 1-800-944-2904 (Mon to Fri 5 am to 6 pm PST, Sat 6 am to 3 pm PST).

Notes: All height, width and depth dimensions are shown in inches. BSH reserves the absolute and unrestricted right to change product materials and specifications, at any time, without notice. Consult the product's installation instructions for final dimensional data and other details prior to making cutout.

Warranties: Please see Use & Care manual or Bosch website for statement of limited warranty.

For more information on our entire line of products, go to www.bosch-home.com/us or call 1-800-944-2904

© BSH Home Appliances Corporation. All rights reserved. Bosch is a registered trademark of Robert Bosch GmbH.

07/18