

Dyna-Glo™

4-BURNER LP GAS GRILL WITH SIDE BURNER

Model #DGE486BSP/DGE486BSP-D/
DGE486GSP/DGE486GSP-D

Français p. 33

Español p. 65



C US

ANS Z21.58b- 2012
CSA 1.6b- 2012
Outdoor Cooking
Gas Appliance

ATTACH YOUR RECEIPT HERE

Serial Number _____ Purchase Date _____



Questions, problems, missing parts? Before returning to your retailer, call our customer service department at 1-877-447-4768, 8:30 a.m. – 4:30 p.m., CST, Monday – Friday or e-mail us at customerservice@ghpgroupinc.com.

PACKAGE CONTENTS

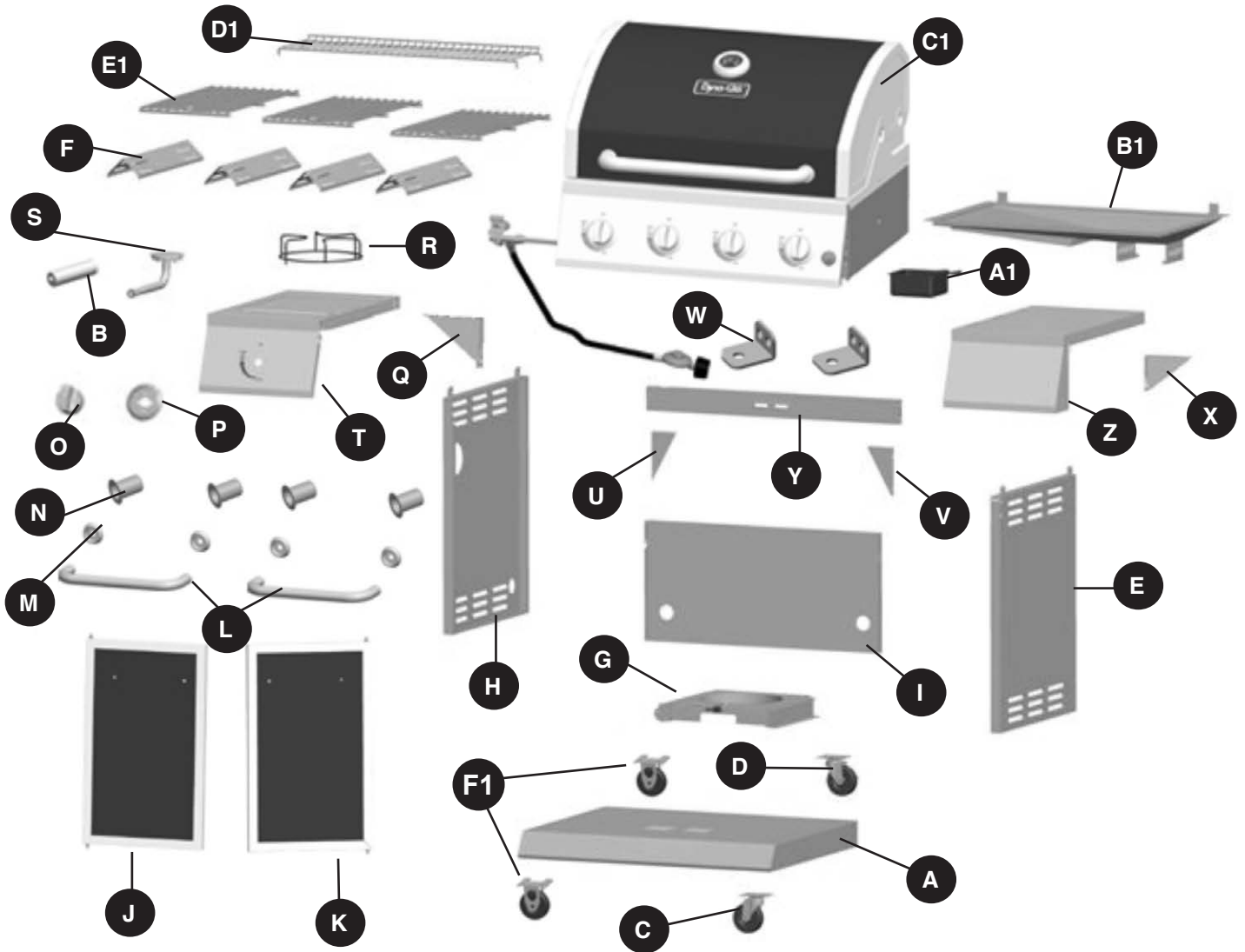

PART	DESCRIPTION	QUANTITY
A	Bottom Shelf	1
B	AA Battery (1.5v)	1
C	Non-Locking Swivel Caster	1
D	Locking Swivel Caster	1
E	Cart Right Side Panel	1
F	Heat Tents	4
G	Tank Shelf	1
H	Cart Left Side Panel	1
I	Cart Rear Panel	1
J	Left Door Assembly	1
K	Right Door Assembly	1
L	Door Handle	2
M	Door Handle Bezel	4
N	Door Handle Sleeve	4
O	Side Burner Control Knob	1
P	Side Burner Control Knob Bezel	1

PART	DESCRIPTION	QUANTITY
Q	Left Side Burner Table Support	1
R	Side Burner Cooking Grate	1
S	Side Burner Assembly	1
T	Left Side Burner Table Assembly	1
U	Left Support - Upper Door Brace	1
V	Right Support - Upper Door Brace	1
W	Support for Door Pin	2
X	Right Side Table Support	1
Y	Upper Front Door Brace	1
Z	Right Side Table Assembly	1
A1	Grease Cup	1
B1	Grease Pan	1
C1	Grill Body	1
D1	Warming Rack	1
E1	Cooking Grate	3
F1	Directional Caster	2

HARDWARE CONTENTS (shown actual size)



M6x12

Qty. 41



M6x12

Qty. 4

NOTE:
4 (AA) screws
preassembled
in door handle.



M6
Plain
Washer

Qty. 26



M6
Spring
Washer

Qty. 16



M4x12
Screw

Qty. 28

PREPARATION

Before beginning assembly of product, make sure all parts are present. Compare parts with package contents list on previous page and hardware contents above. If any part is missing or damaged, do not attempt to assemble the product. Contact customer service for replacement parts.

Estimated Assembly Time: 50 minutes with 2 people.

Tools Required for Assembly and Leak Testing (not included): Phillips screwdriver, Spray bottle

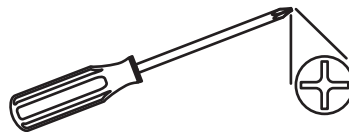

⚠ CAUTION

THIS UNIT IS HEAVY. Two people required for safe assembly.



Two people required for safe assembly. Some parts may contain sharp edges. Wear protective gloves if necessary. Read and follow all safety statements, warnings, assembly instructions and use and care instructions before attempting to assemble and use.

ASSEMBLY INSTRUCTIONS

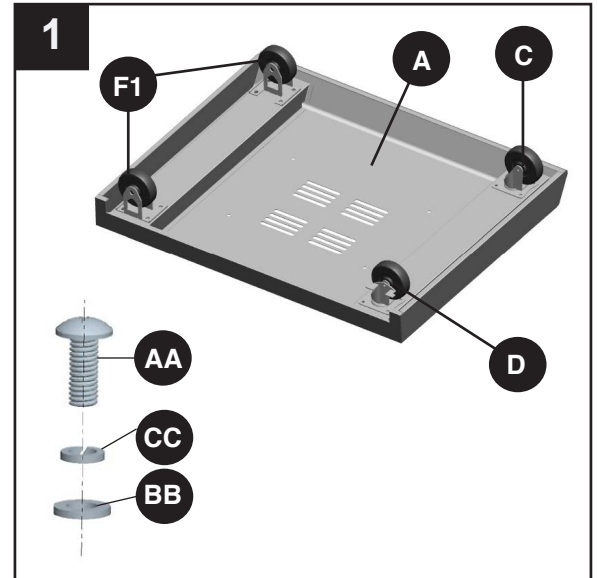
- Assemble the casters, including 2 directional casters (F1), 1 non-locking swivel caster (C), 1 locking swivel caster (D), onto bottom shelf (A) with 4 M6 screw (AA), plain washer (BB) and spring washer (CC) for each caster as shown.



Hardware Used

AA	M6x12 Screw		x 16
BB	Plain Washer		x 16
CC	Spring Washer		x 16

- Insert 4 screws (AA) into holes in bottom shelf (A), leaving 4-6mm clearance from screw head to bottom shelf (A). Attached cart left side panel (H) by placing the panel keyhole over the screw heads (AA) on the left side of bottom shelf (A), slide the cart left side panel (H) so that the screw head is over the smaller part of keyhole. Thread the screw (AA) down snug but do not tighten at this step. Repeat with cart right side panel (E).

Hardware Used

AA	M6x12 Screw		x 4
-----------	-------------	---	-----

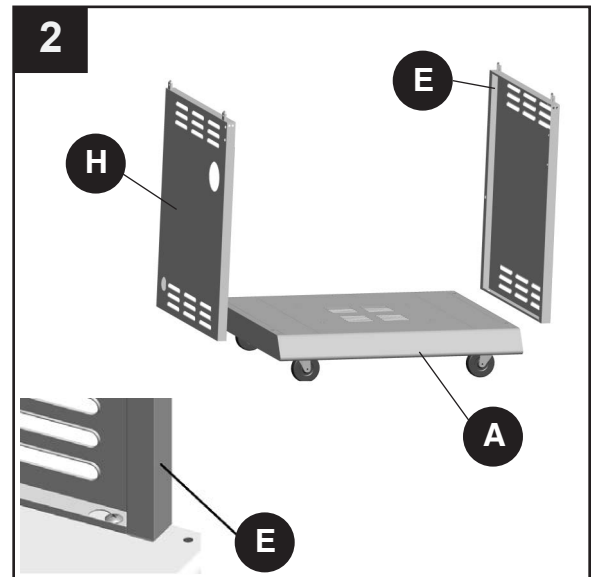

ASSEMBLY INSTRUCTIONS

3. Insert one screw (AA) into the rear holes of the cart left side panel and cart right side panel (H&E), leaving 4-6mm clearance from screw head to the side panels (H&E). Attached the cart rear panel (I) by sliding the keyholes in the cart rear panel over the inserted screws and then push with force. Secure the cart rear panel (I) to the bottom shelf (A) using 3 screws (AA). Tighten the 2 screws on the side panels (H&E).

Hardware Used

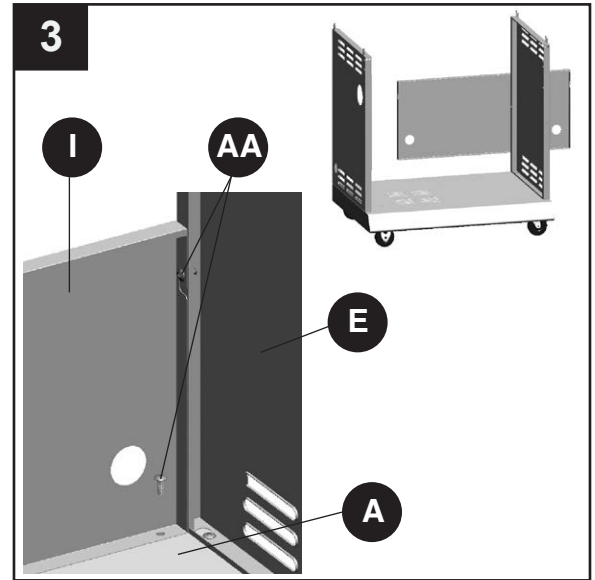

4. Align upper front door brace (Y) to the holes 1 on cart left side panel (H). Secure upper front door brace to 2 using 2 screws (AA). Repeat and secure upper front door brace (Y) to cart right side panel (E).

Hardware Used

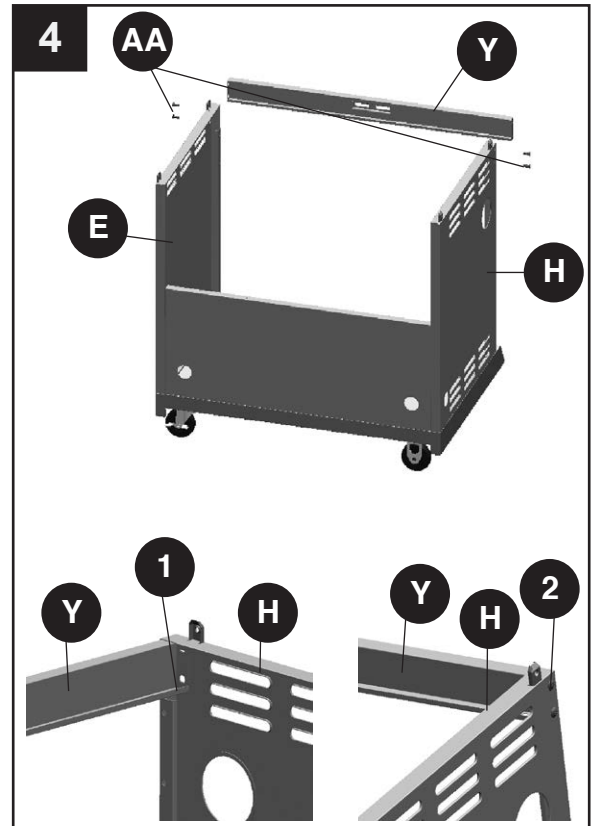

ASSEMBLY INSTRUCTIONS

5. Insert 2 screws (DD) into left edge of upper front door brace (Y), but do not tighten. Leave 4-6mm clearance from screw head to the bottom of upper front door brace (Y). Attached left support for upper front door brace (U) onto the inserted screws. Secure with 2 additional screws (DD) and tighten all four screws (DD). Repeat with right support for upper front door brace (V).

Hardware Used

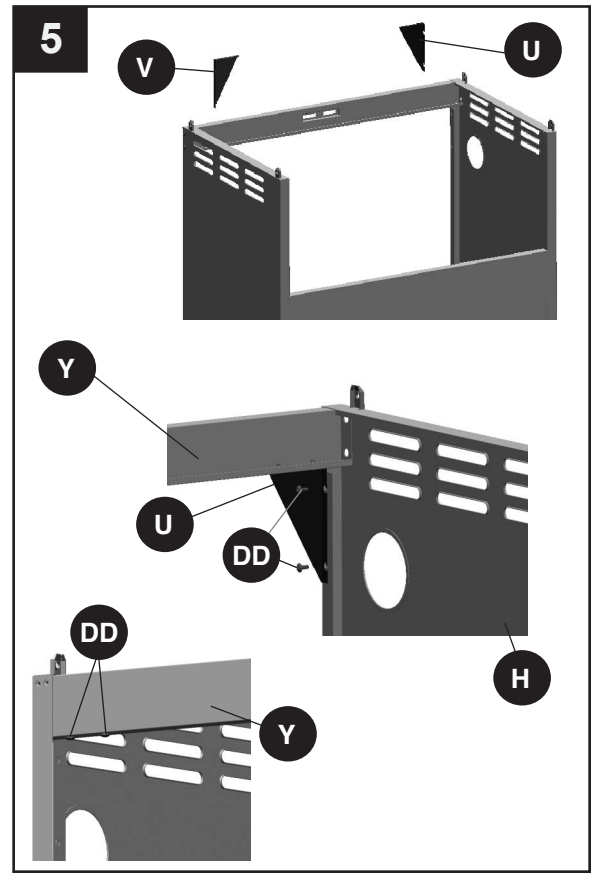

6. Remove preassembled 2 screws (AA) and door handle sleeve (N) from the door handle (L). Insert the 2 door sleeves (N) into the holes located on the back of the door assembly (J), Insert 2 screws (AA) into the door handle sleeve (N), through the door handle bezels (M) and into the thread holes in the door handles (L). Tighten the screws. As shown on below figure. Repeat with right door assembly (K).

Hardware Used

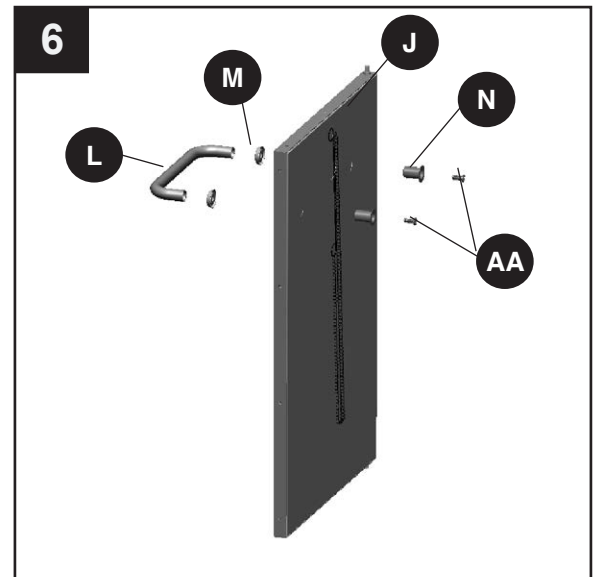

ASSEMBLY INSTRUCTIONS

7. Insert the bottom axis in left door assembly (J) into the hole (1) on bottom shelf. Insert the upper axis in left door assembly (J) into the hole of support for door pin (W), secure support for door pin (W) to cart left side panel (H) using 2 screw (DD). Repeat with right door assembly (K).

Hardware Used

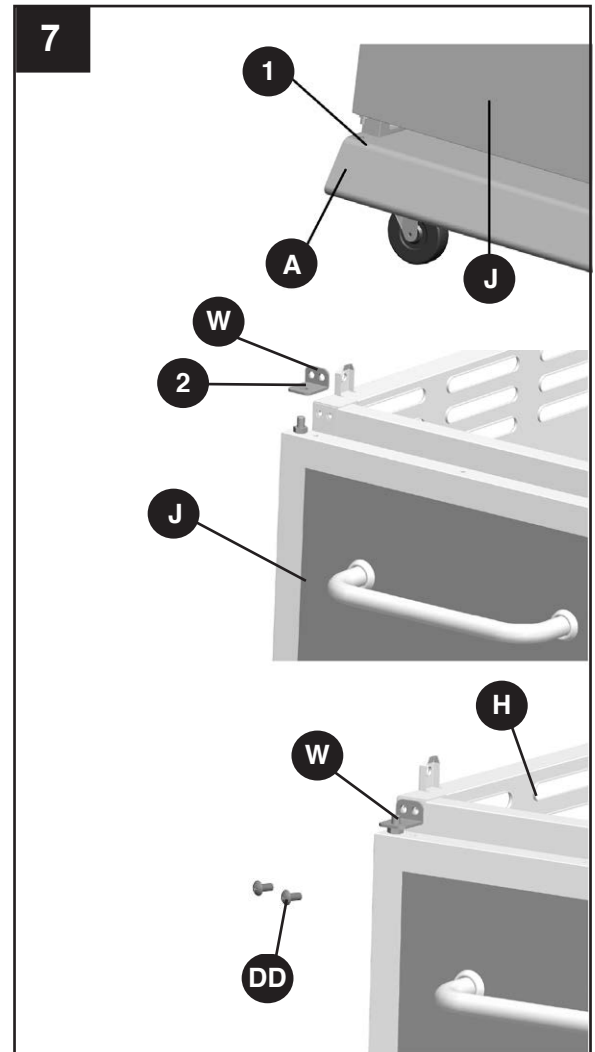

8. Place tank shelf (G) onto bottom shelf (A) with care. Secure the right of tank shelf (G) to bottom shelf (A) using 2 screws (DD) and tighten the screws. Repeat and secure the left of tank shelf (G).

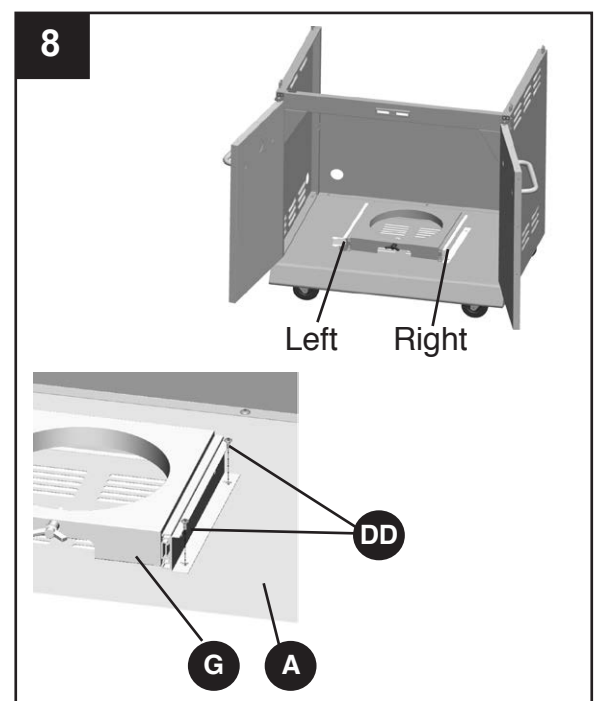

Hardware Used



ASSEMBLY INSTRUCTIONS

9. Carefully place the grill body (C1) onto the cart left side panel and cart right side panel (H&E). Adjust the grill body (C1) so that the holes in the grill body (C1) are aligned with the holes in the tabs of the cart side panels (H&E).
NOTE: Make sure the gas hose/regulator assembly is outside the cart. Fasten the grill body (C1) using 2 screws (AA) and plain washer (BB) on each side.

Hardware Used

- AA** M6x12 Screw  x 4
- BB** M6 Plain Washer  x 4

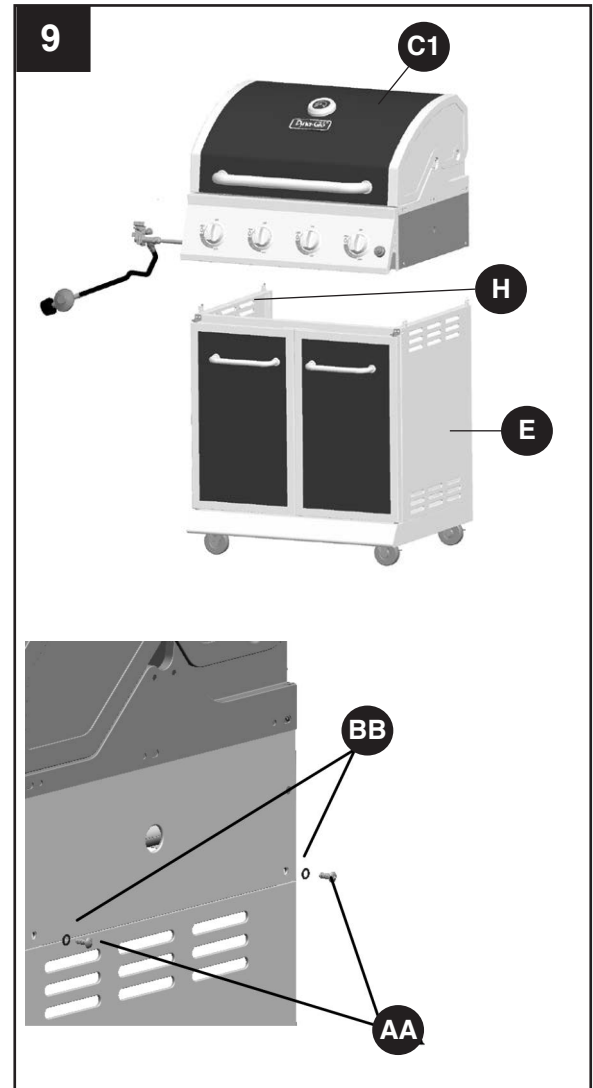

10. Secure support for left side burner table (Q) to left side burner table assembly (T) using 2 screws (DD).

Secure support for right side table (X) to right side table assembly (Z) using 2 screws (DD).

Hardware Used

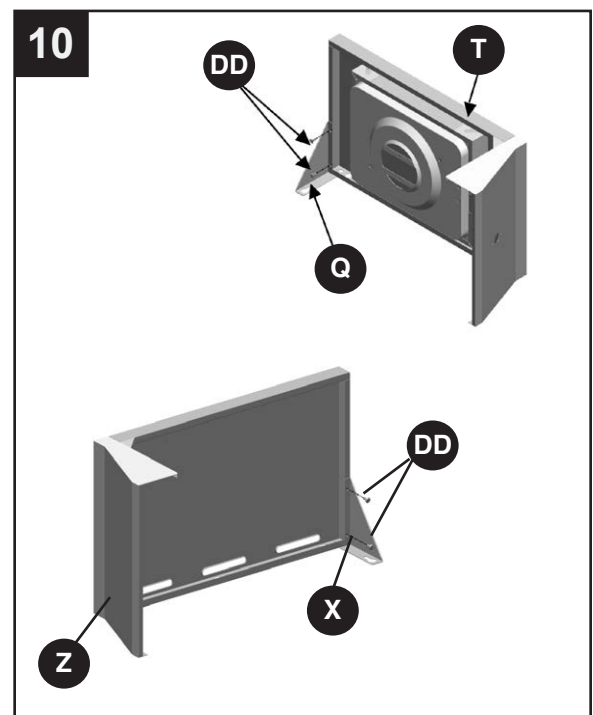

- DD** M4x12 Screw  x 4



ASSEMBLY INSTRUCTIONS

11. Insert 1 pc M6x12 Screw (AA) and 2 pcs M4x12 Screw (DD) to grill body (C1), leaving 4-6mm clearance from screw head to grill body (C1). Align left side burner table assembly (T) to the 3 inserted screws. Insert 3 screws (AA) with plain washers (BB) from the holes of grill body (C1) out to the left side burner table assembly (T). Secure using 1 screw (DD). Adjust left side burner table assembly (T) correctly then tighten all screws.

Hardware Used

AA	M6x12 Screw		x 4
BB	Plain Washer		x 3
DD	M4x12 Screw		x 3

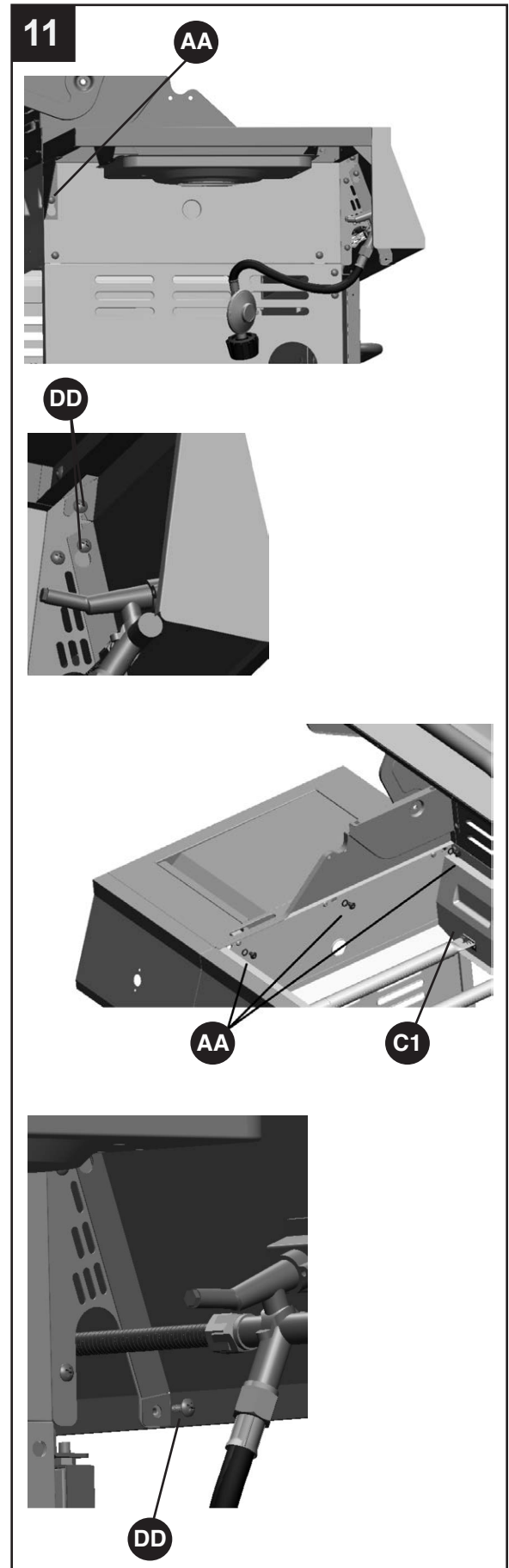

ASSEMBLY INSTRUCTIONS

12. Remove pre-assembled 2 screws from the bracket in the side burner valve assembly. Secure side burner valve assembly and side burner control knob bezel (P) to the side table by placing the side burner valve assembly under the side table and sliding the valve stem through the hole in the side table front facing and hold in place. Place the side burner control knob bezel (P) over the valve stem on the outside of the side table front facing, lining up the holes in the bezel with the holes in the valve assembly. Secure by replacing the screws removed earlier in this step. Tighten screws. Slide side burner control knob (O) over valve stem.

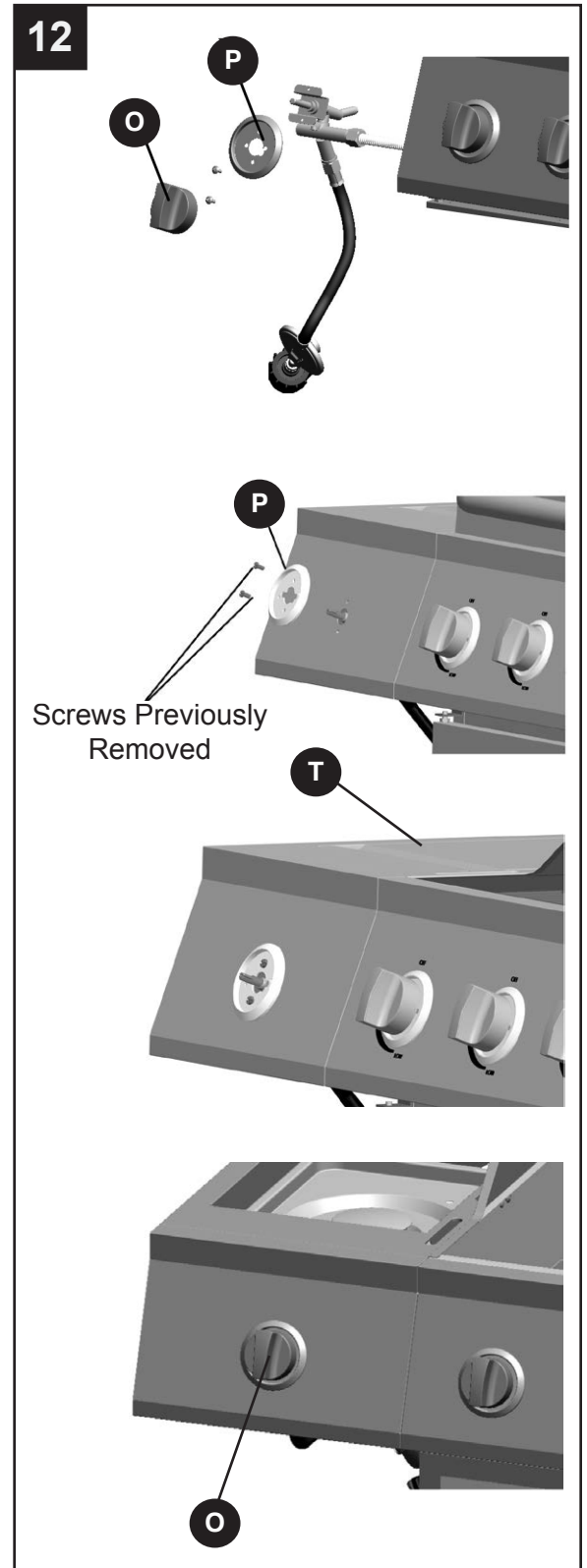

ASSEMBLY INSTRUCTIONS

13. Secure side burner assembly (S) to left side burner table assembly (T) using 2 screws (DD). Ensure side burner orifice placed into the gas inlet tube of side burner. Install the ignition wiring to the electrode assembly.

Hardware Used

DD M4x12 Screw  x 2

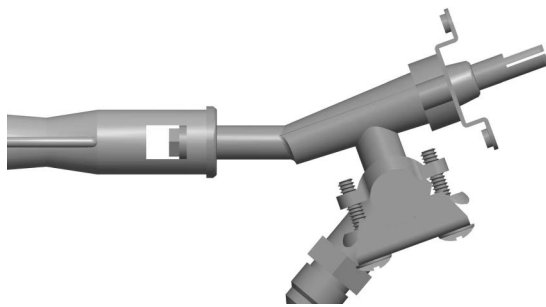

Correct

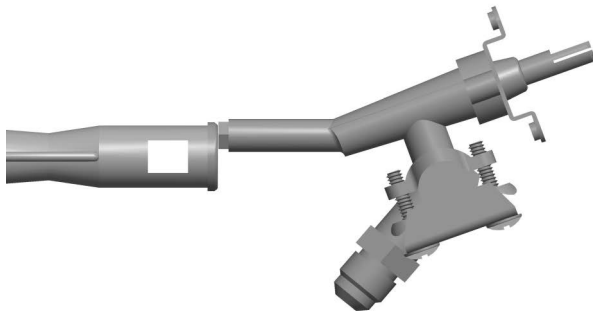

Wrong

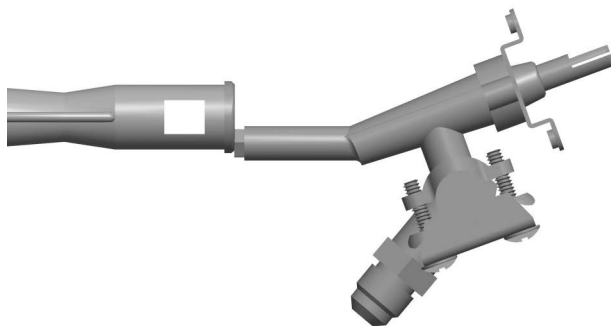

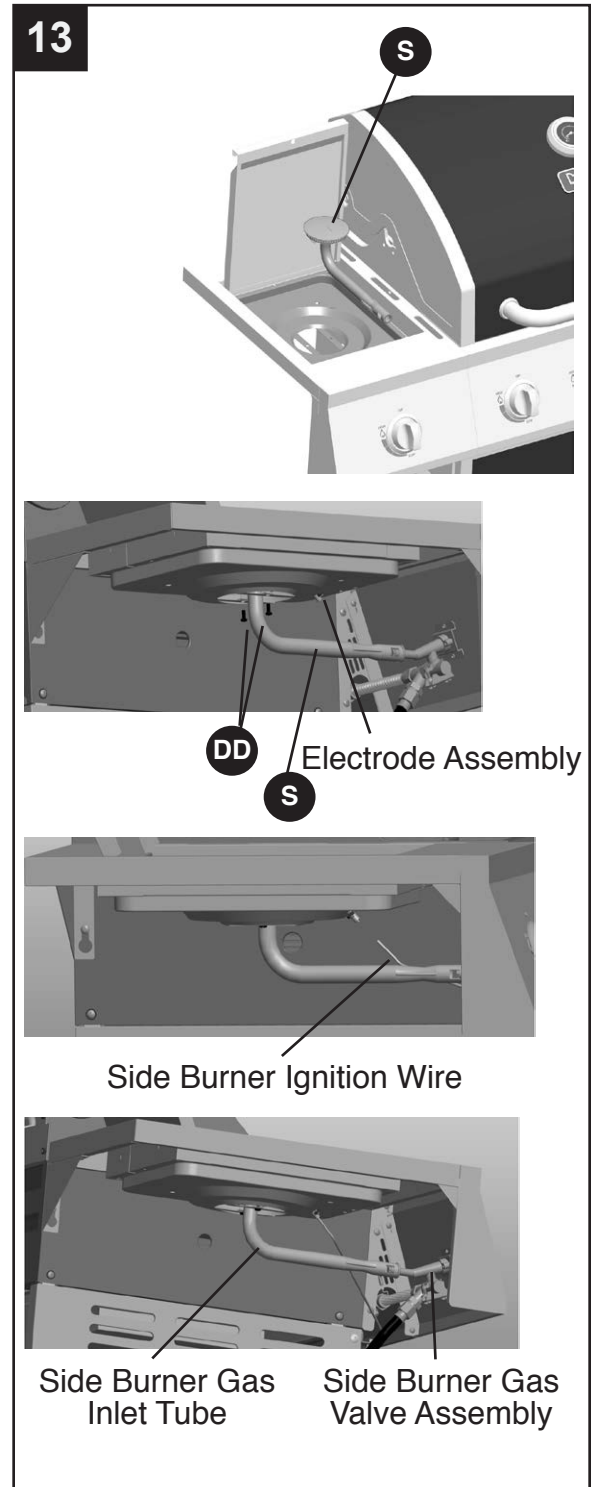

Wrong



ASSEMBLY INSTRUCTIONS

14. Insert 1 M6x12 screw (AA) Screw and 2 M4x12 Screws (DD) to grill body (C1), leaving 4-6mm clearance from screw head to grill body (C1). Align right side table assembly (Z) to the 3 inserted screws. Insert 3 M6x12 screws (AA) with plain washers (BB) from the holes of grill body (C1) out to the right side table assembly (Z). Secure right side table assembly (Z) using 1 M4x12 screw (DD). Adjust the right side table assembly (Z) correctly then tighten all screws.

Hardware Used

AA	M6x12 Screw		x 4
BB	Plain Washer		x 3
DD	Spring Washer		x 3

⚠ WARNING: IT IS VERY IMPORTANT TO CHECK AND ENSURE THAT EACH AND EVERY BURNER IS FULLY ENGAGED WITH THE ADJACENT VALVE ORIFICE BEFORE COMPLETING STEP 15. FAILURE TO DO SO MAY

RESULT IN FIRE OR EXPLOSION, POSSIBLY CAUSING SERIOUS

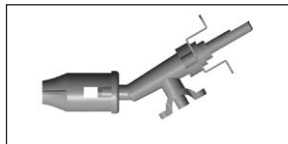

INJURY OR DEATH. REFER TO MAINTENANCE SECTION INSTRUCTIONS TO PROPERLY CHECK THE ENGAGEMENT.

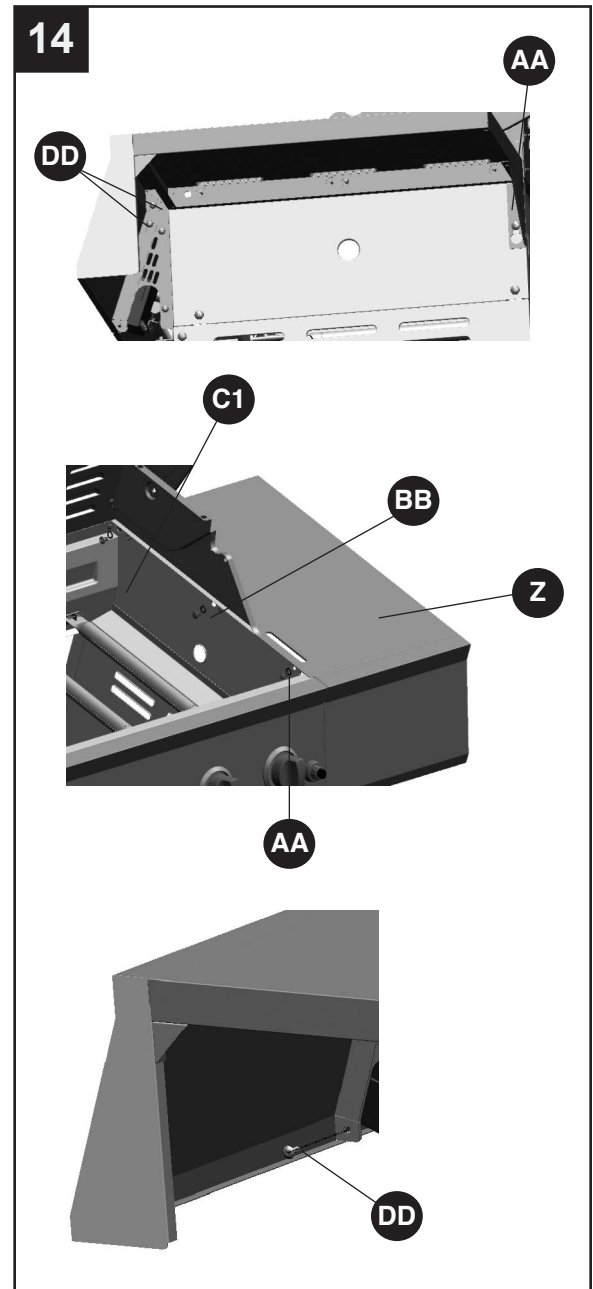

ASSEMBLY INSTRUCTIONS

15. Open the lid, place 4 heat tents (F), 3 cooking grates (E1) and 1 warming rack (D1) on the inside of the grill body (C1). Place side burner cooking grate (R) onto left side burner table (T). Insert the warming rack (D1) into the four holes located on both sides of grill body.

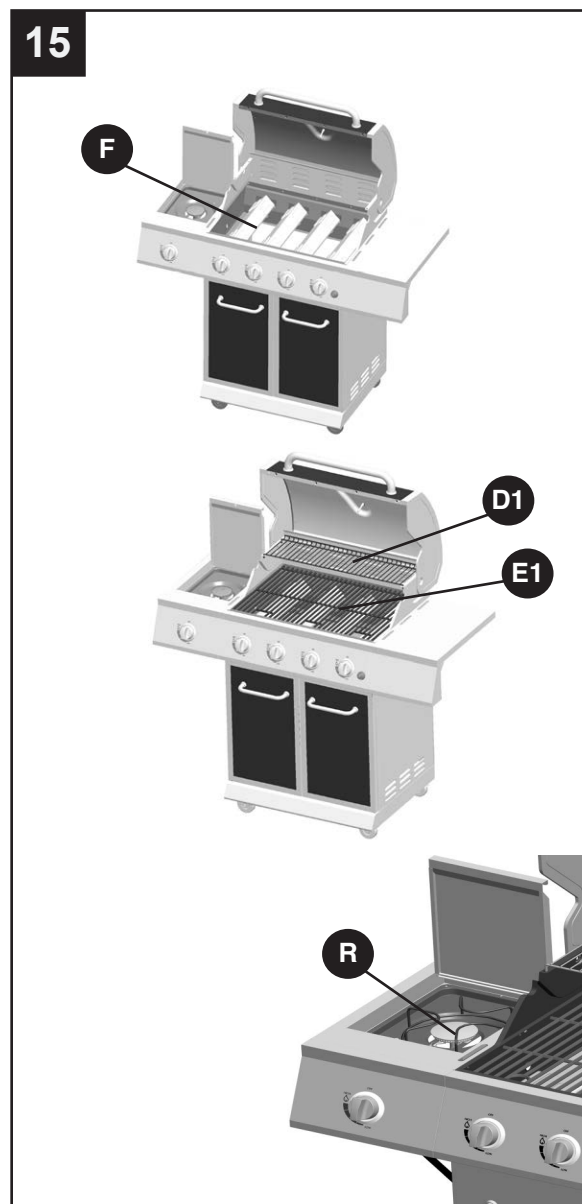

16. Remove the igniter cap, insert AA battery (B) into the igniter body with positive '+' end facing out. Replace the igniter cap.

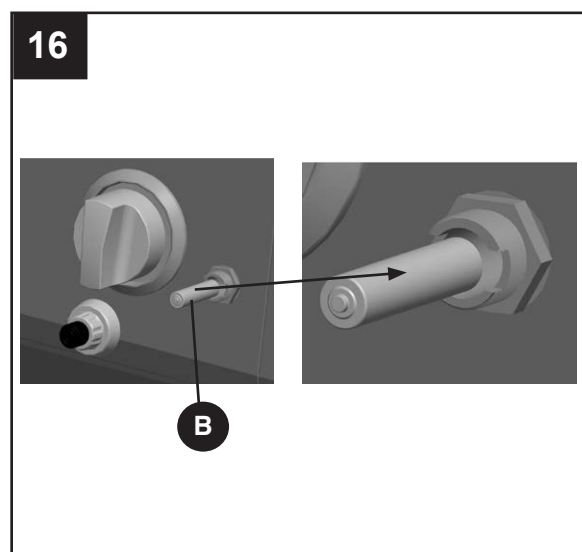

ASSEMBLY INSTRUCTIONS

17. Insert the grease pan (B1) into position by sliding it in the grill body from the rear as shown on below figure, along the rails located just below the underside of grill body.

NOTE: Pay attention and do not slide the grease pan from opposite position. Insert grease cup (A1) into position by sliding it onto the rail on the bottom side of grease pan as shown.

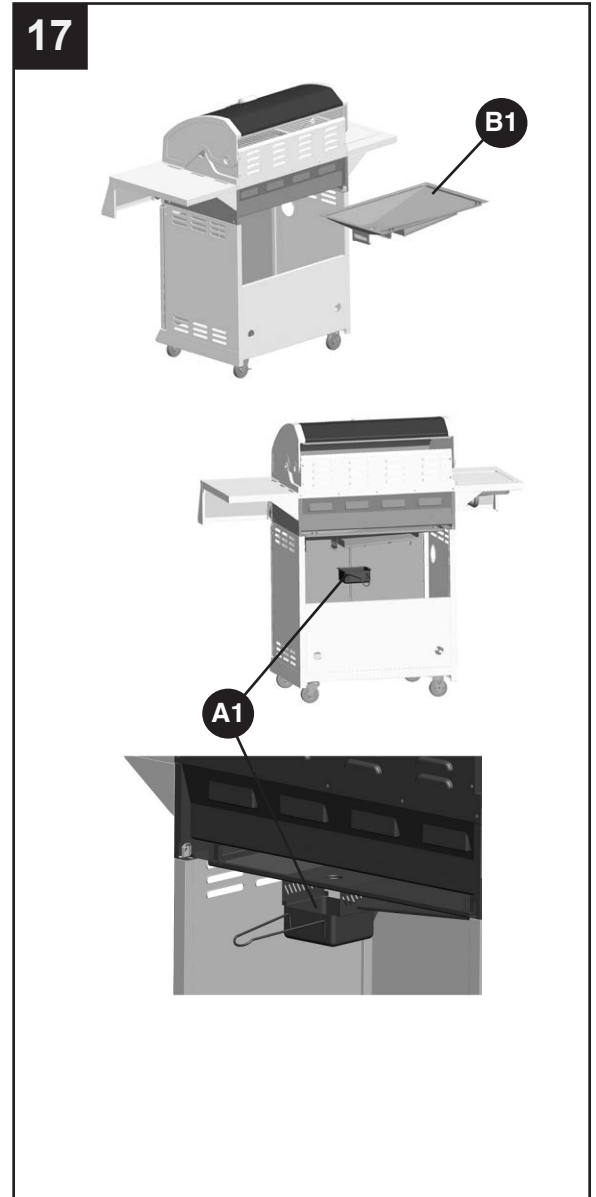

ASSEMBLY INSTRUCTIONS

18. Open the cart door assembly (J&K), insert hose/regulator assembly into the cart assembly through the hole on cart left side panel (H). Pull the tank shelf (G) out of the cart, place gas cylinder (sold separately) onto tank shelf (G). Rotate the gas cylinder until the hose/regulator coupling can easily be attached to the valve on the LP cylinder. Hand-tighten the hose/regulator coupling to the threaded valve of the LP gas cylinder. Tighten gas cylinder retaining bolt. Slide tank shelf (G) back into cart and secure in place by swinging the tank shelf rail locking plate over and in front of the tank shelf (G).

Fully Assembled



Front View



Rear View

18

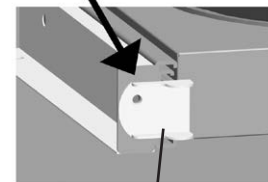
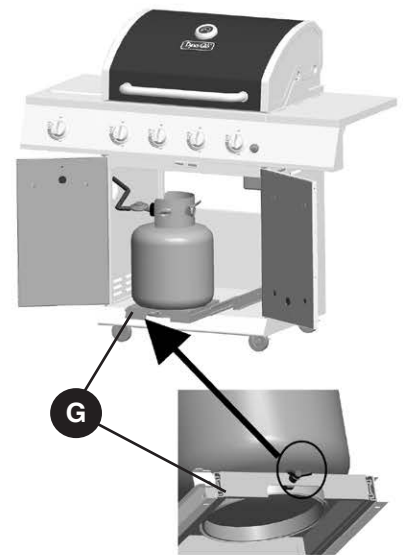

Tank shelf rail locking plate

Dyna-Glo™

BARBECUE AU GAZ LP À 4 BRÛLEURS

Modele #DGE486BSP/DGE486BSP-D/
DGE486GSP/DGE486GSP-D



C US

ANS Z21.58b- 2012
CSA 1.6b- 2012
Cuisine de plein air
Appareils à gaz

JOIGNEZ VOTRE REÇU ICI

Numéro de série _____ Date d'achat _____



Des questions, des problèmes, des pièces manquantes? Avant de retourner l'article au détaillant, appelez notre service à la clientèle au 1-877-447-4768, 08:30-16 heures 30, HNC, du lundi - vendredi ou par e-mail à customerservice@ghpgroupinc.com.

QUINCAILLERIE INCLUSE (grandeur réelle)

				
				
Vis M6 de 12 mm	Vis M6 de 12 mm	Rondelle ordinaire	Rondelle à ressort	Vis M4 de 12 mm
Qté : 41	Qté : 4	Qté : 26	Qté : 16	Qté : 28

REMARQUE :
Préassemblée
à la poignée
de porte.

PRÉPARATION

Avant de commencer l'assemblage du produit, assurez-vous d'avoir toutes les pièces. Comparez les pièces dans l'emballage avec la liste des pièces de la page précédente et la quincaillerie indiquée ci-dessus. S'il y a des pièces manquantes ou endommagées, ne tentez pas d'assembler le produit. Communiquez avec le service à la clientèle pour obtenir des pièces de rechange.

Temps d'assemblage approximatif : 50 minutes, par deux personnes

Outils nécessaires pour l'assemblage et la vérification des fuites (non inclus) : tournevis cruciforme et vaporisateur

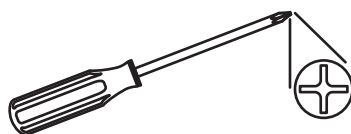

⚠ MISE EN GARDE

CET ARTICLE EST LOURD. DEUX PERSONNES SONT NÉCESSAIRES POUR ASSEMBLER L'ARTICLE EN TOUTE SÉCURITÉ.

Deux personnes sont nécessaires pour l'assembler en toute sécurité. Soyez prudent, car certaines pièces peuvent avoir des bords coupants. Au besoin, portez des gants protecteurs. Lisez et respectez tous les énoncés sur la sécurité et les avertissements, et suivez toutes les instructions pour l'assemblage ainsi que la section sur l'entretien de l'article avant de tenter d'assembler et d'utiliser cet article.

INSTRUCTIONS POUR L'ASSEMBLAGE

1. Assemblez les roulettes, dont 2 roulettes directionnelles (F1) et les 1 roulettes orientables (B), 1 roulette sans verrou (C), 1 roulette à verrou (D) sur l'étagère du bas (A) avec 4 vis M6 (AA), rondelle plate (BB) et rondelle à ressort (CC). Tel qu'illustré ci-bas.

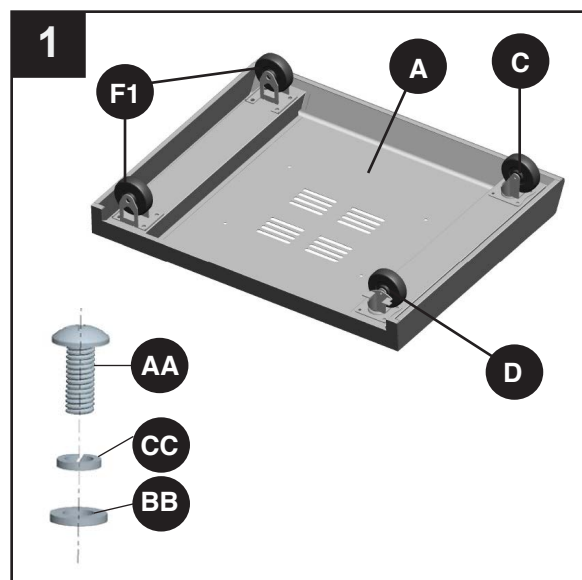

Quincaillerie utilisée

AA	Vis M6 de 12 mm		x 16
BB	Rondelle ordinaire		x 16
CC	Rondelle à ressort		x 16

2. Insérez 4 vis (AA) dans les trous de l'étagère du bas (A). Laissez un écart de 4-6mm entre la tête de vis et l'étagère du bas (A). Installez le panneau gauche (H) en plaçant le trou de serrure sur la tête de vis (AA) sur le côté gauche de l'étagère du bas (A), glissez le panneau gauche du charriot (H) de manière à placer la tête de vis au-dessus de la petite section du trou de serrure. Insérez la vis (AA), mais ne la serrez pas complètement à ce stade-ci. Faites la même chose avec le panneau droit du charriot (E).

Quincaillerie utilisée

AA	Vis M6 de 12 mm		x 4
-----------	--------------------	--	-----

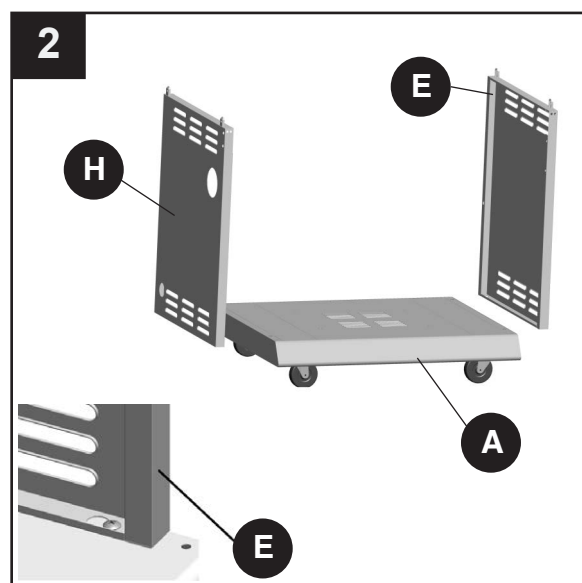

INSTRUCTIONS POUR L'ASSEMBLAGE

3. Insérez une vis (AA) dans les trous à l'arrière du panneau gauche et panneau droit du charriot (H&E). Laissez un écart de 4-6mm entre la tête de la vis et les panneaux latéraux (H&E). Fixez le panneau arrière du charriot (I) en glissant les trous de serrure du panneau arrière dans les vis et en appuyant. Fixez le panneau arrière (I) à l'étagère du bas (A) avec 3 vis (AA). Serrez les 2 vis sur les panneaux latéraux (H&E).

Quincaillerie utilisée

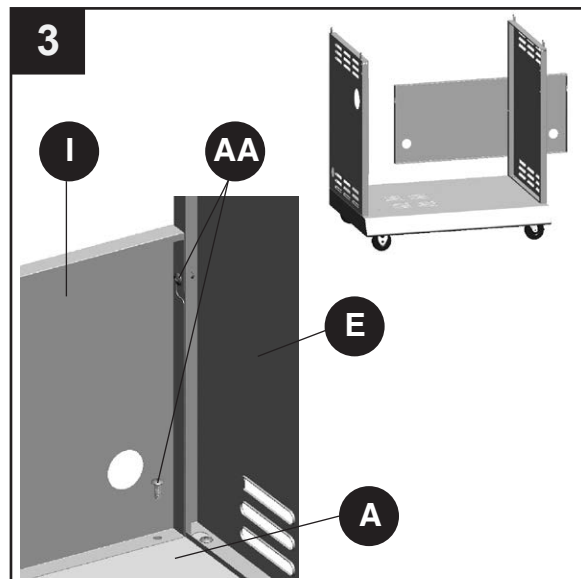

4. Alignez le renfort supérieur de la porte avant (Y) aux trous 1 du panneau gauche du charriot (H). Fixez le renfort supérieur de la porte 2 avec 2 vis (AA). Faites la même chose avec le renfort supérieur de la porte (Y) et le panneau droit (E).

Quincaillerie utilisée

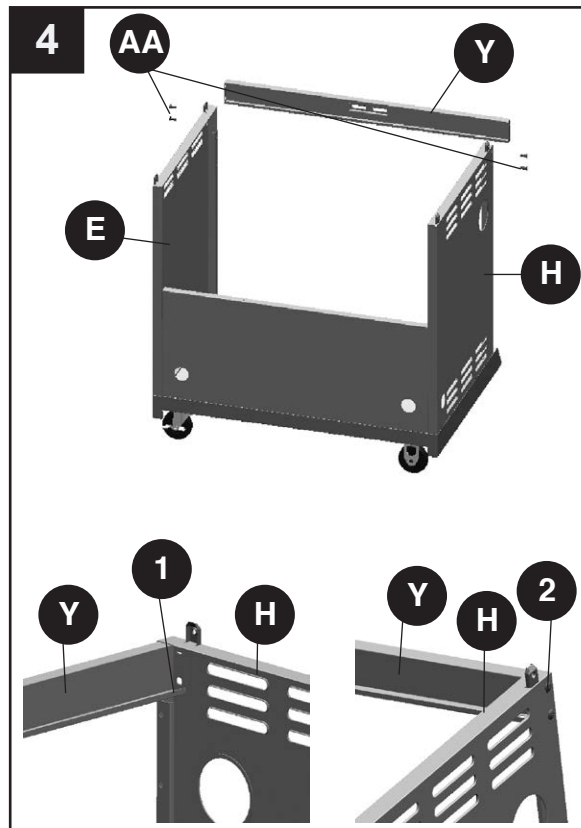

INSTRUCTIONS POUR L'ASSEMBLAGE

5. Insérez 2 vis (DD) sur le rebord gauche en haut du renfort de la porte (Y), mais ne serrez pas. Laissez un écart de 4-6mm entre la tête de la vis et le bas du renfort de la porte avant (Y). Fixez le support du renfort supérieur de la porte avant (U) dans les vis. Faites tenir avec 2 autres vis (DD) et serrez toutes (DD). Faites la même chose avec le support du renfort supérieur de la porte avant (V).

Quincaillerie utilisée

DD

Vis M4
de 12 mm



x 8

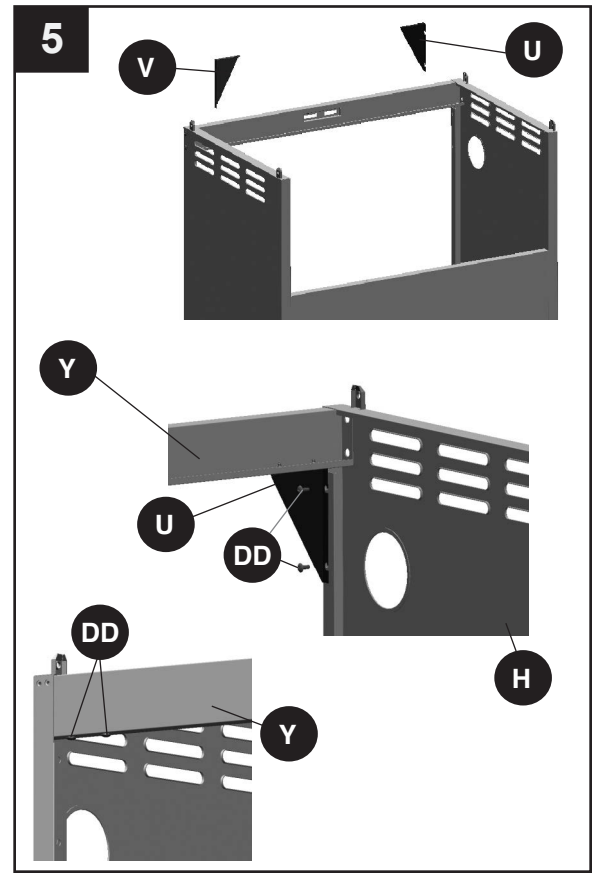

6. Enlevez les 2 vis (AA) et la ferrure de la poignée de porte (N) de la poignée (L). Insérez les 2 ferrures (N) dans les trous à l'arrière de l'assemblage de la porte (J). Insérez 2 vis (AA) dans la ferrure de poignée (N) à travers le chanfrein de la poignée (M), et dans les trous des poignées (L). Serrez les vis. Tel qu'illustré ci-bas. Faites la même chose avec l'assemblage de la porte droite.

Quincaillerie utilisée

AA

Vis M6
de 12 mm



x 4

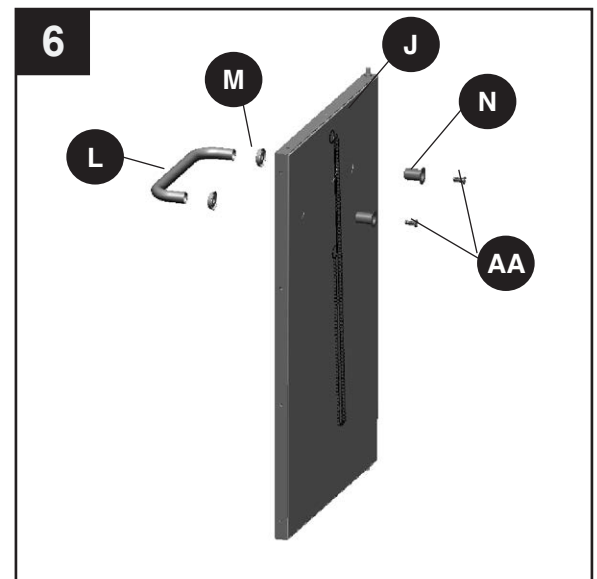

INSTRUCTIONS POUR L'ASSEMBLAGE

7. Insérez l'axe du bas de l'assemblage de la porte gauche (J) dans le trou (1) de l'étagère du bas. Insérez l'axe du haut de l'assemblage de la porte gauche (J) dans le trou du pivot de porte (W). Fixez le support du pivot de porte (W) au panneau gauche du charriot (H) avec 2 vis (DD). Faites la même chose avec la porte droite (K).

Quincaillerie utilisée

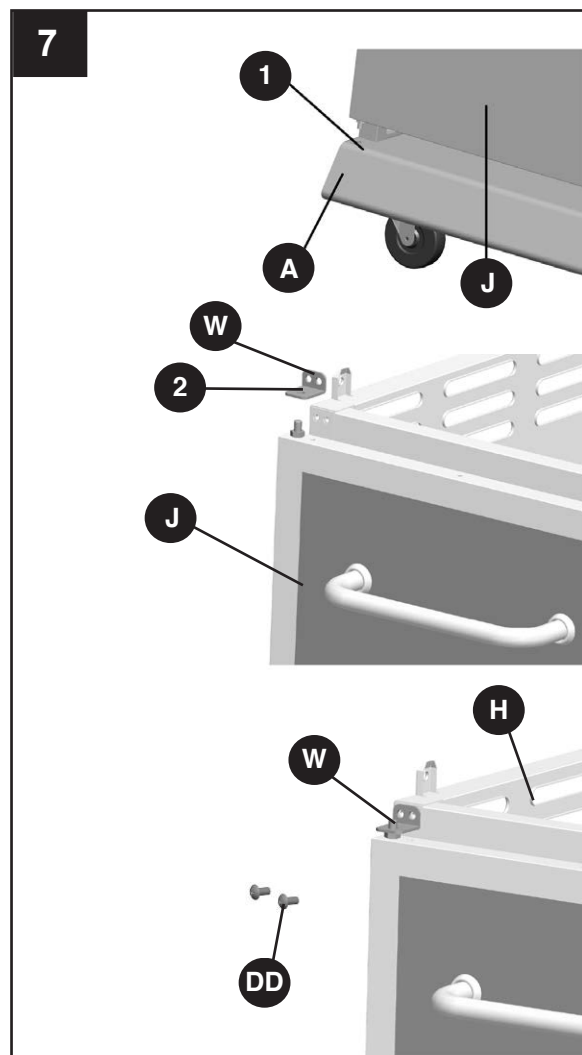

8. Placez avec prudence l'étagère du réservoir (G) sur l'étagère du bas (A). Fixez le côté droit de l'étagère du réservoir (G) à l'étagère du bas (A) avec 2 vis (DD). Serrez les vis. Faites la même chose avec le côté gauche de l'étagère (G).

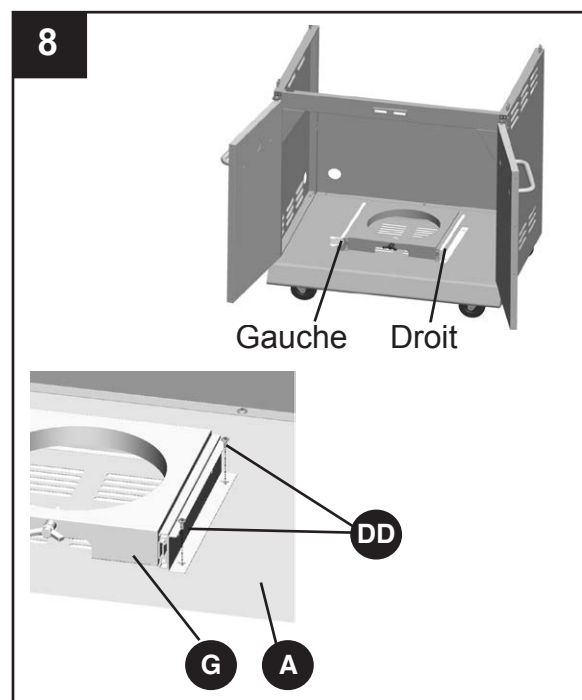

Quincaillerie utilisée



INSTRUCTIONS POUR L'ASSEMBLAGE

9. Installez prudemment le cadre du barbecue (C1) sur le panneau gauche et le panneau droit du charriot (H&E). Ajustez le cadre du barbecue (C1) afin que les trous du cadre (C1) soient alignés avec les trous des languettes des panneaux latéraux du charriot (H&E).
NOTE: Soyez certain que l'assemblage (tuyau/régulateur de gaz) est à l'extérieur du charriot. Fixez le cadre du barbecue (C1) avec 2 vis (AA) et rondelle plate (BB) de chaque côté.

Quincaillerie utilisée

AA	Vis M6 de 12 mm		x 4
BB	Rondelle ordinaire		x 4

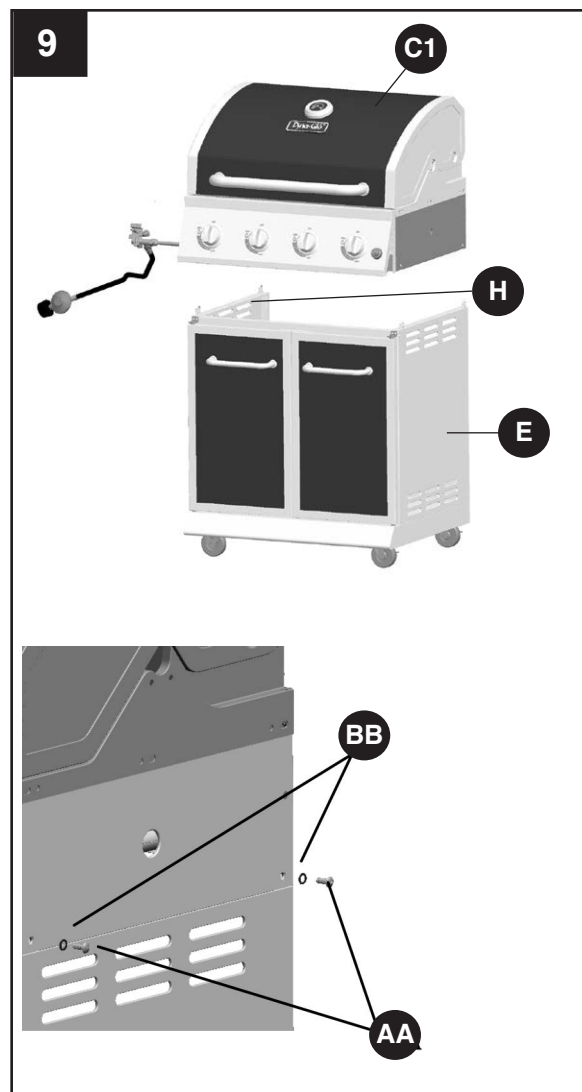

10. Fixez le côté gauche de la table du brûleur (Q) à l'assemblage du côté gauche de la table du brûleur (T) avec 2 vis (DD).

Fixez le côté droit de la table du brûleur (X) à l'assemblage du côté droit de la table du brûleur (Z) avec 2 vis (DD).

Quincaillerie utilisée

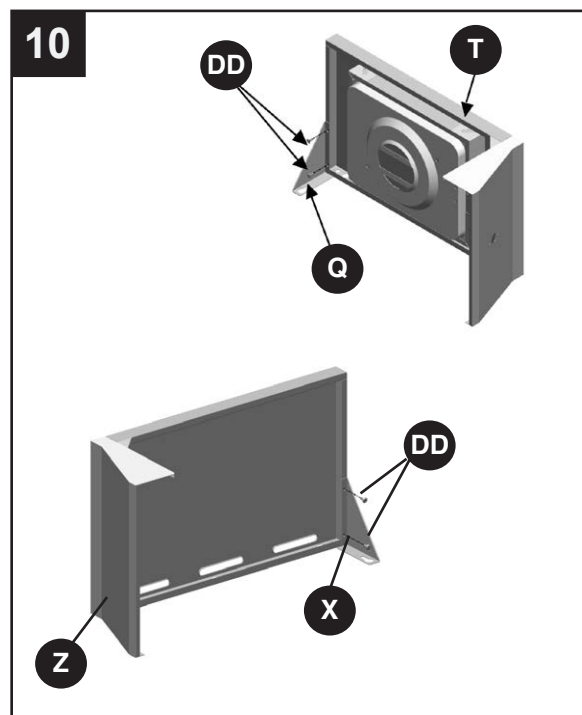

DD	Vis M4 de 12 mm		x 4
-----------	-----------------	---	-----



INSTRUCTIONS POUR L'ASSEMBLAGE

11. Insérez 1 paq. M6x12 vis (AA) et 2 paq. M4x12 vis (DD) au cadre du barbecue (C1). Laissez un écart de 4-6mm entre la tête de vis et le cadre du barbecue (C1). Alignez le côté gauche de l'assemblage de la table du brûleur (T) aux 3 vis insérées. Insérez 3 vis (AA) et des rondelles plates (BB) dans les trous du cadre du barbecue (C1) jusqu'à l'assemblage gauche de la table du brûleur (T). Fixez avec 1 vis (DD). Ajustez l'assemblage gauche de la table du brûleur (T), et serrez toutes les vis.

Quincaillerie utilisée

AA	Vis M6 de 12 mm		x 4
BB	Rondelle ordinaire		x 3
DD	Vis M4 de 12 mm		x 3

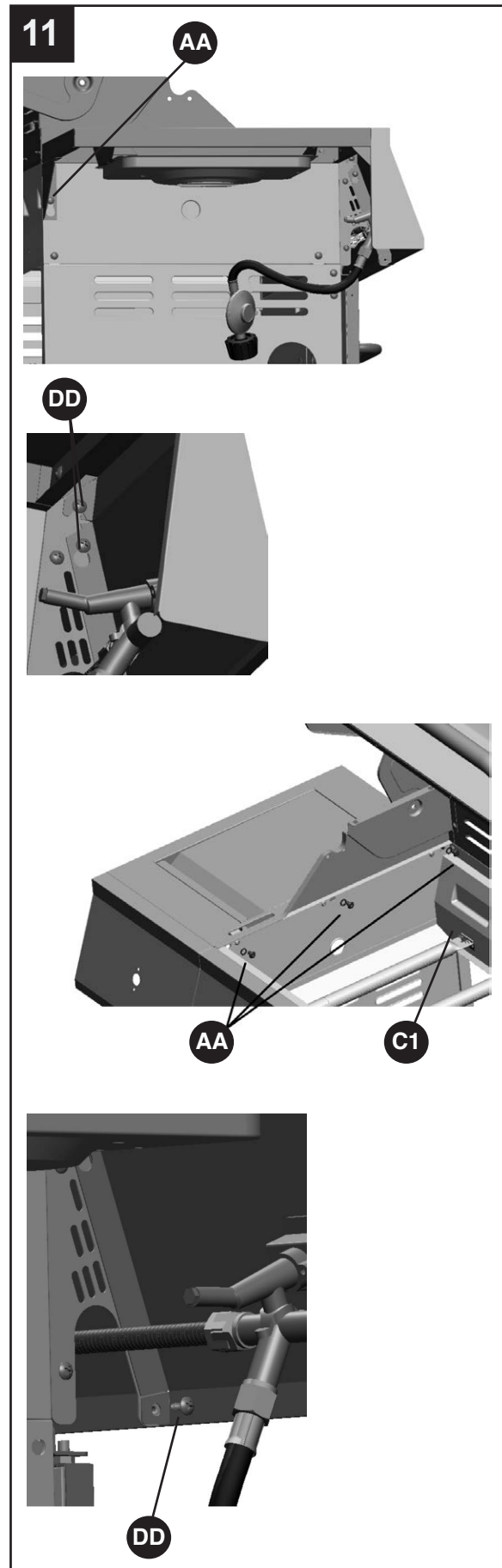

INSTRUCTIONS POUR L'ASSEMBLAGE

12. Retirer pré-assemblés 2 vis de la support dans la valve du brûleur latéral. Enlevez le bouton de réglage du brûleur du côté (O) et le chanfrein du bouton de réglage du brûleur du côté (P) de l'assemblage de la valve du brûleur du côté. Fixez l'assemblage de la valve du brûleur du côté et le chanfrein du bouton de réglage du brûleur du côté (P) à la table du côté en plaçant l'assemblage de la valve du brûleur du côté en-dessous de la table du côté et en glissant la tige de la soupape dans le trou vers l'avant de la table du côté et tenez-la. Placez le chanfrein du bouton de réglage du brûleur du côté (P) au-dessus de la tige de la soupape à l'extérieur de la table du côté vers l'avant, alignez les trous du chanfrein aux trous de l'assemblage de la soupape.

Faites tenir en fixant les vis enlevées préalablement. Serrez les vis . Glissez le bouton de réglage du brûleur du côté (O) sur la tige de la soupape.

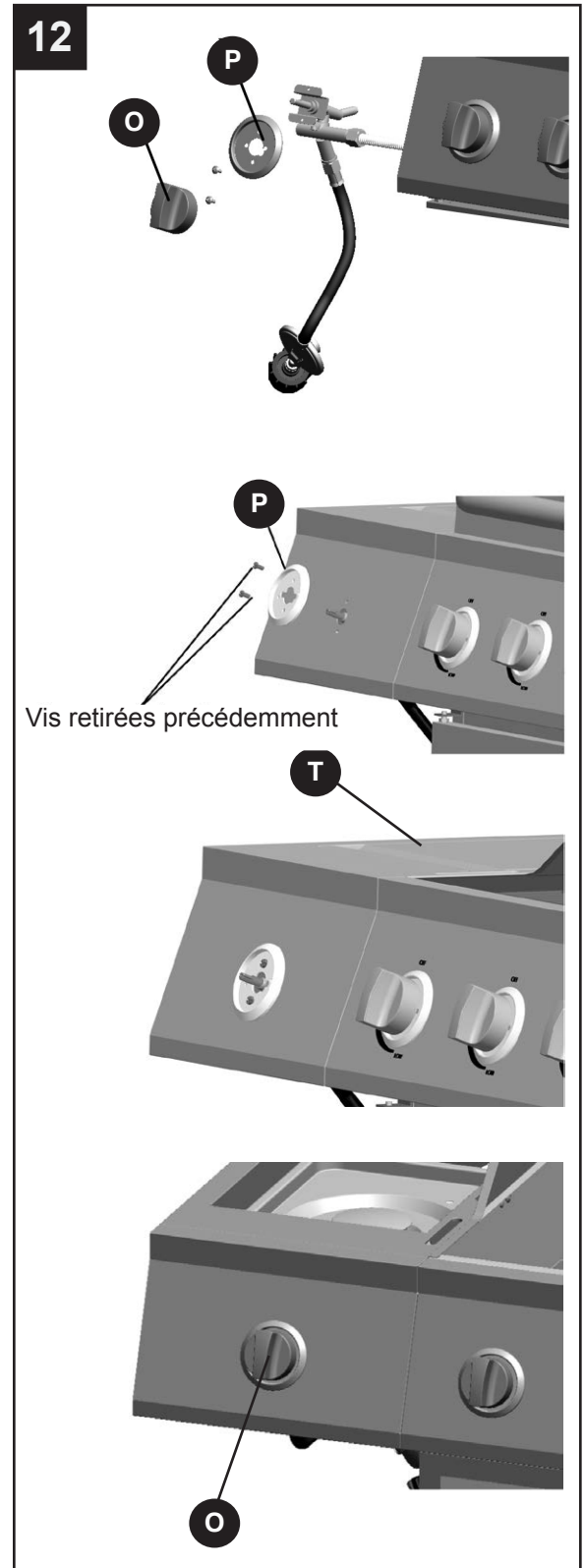

INSTRUCTIONS POUR L'ASSEMBLAGE

13. Fixez l'assemblage du brûleur du côté (S) à l'assemblage gauche de la table du brûleur (T) avec 2 vis (DD). Soyez certain que le trou du brûleur du côté est sur le tuyau d'admission de gaz du brûleur du côté.

Installez le fil d'allumage au jeu d'électrodes.

Quincaillerie utilisée

DD Vis M4 de 12 mm  x 2

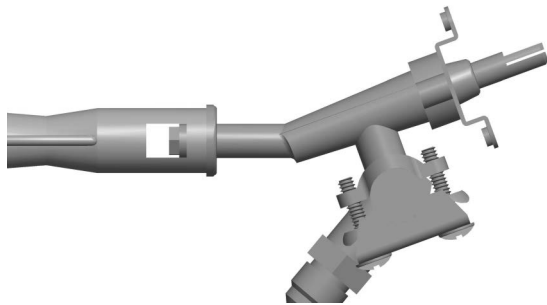

Corrigez

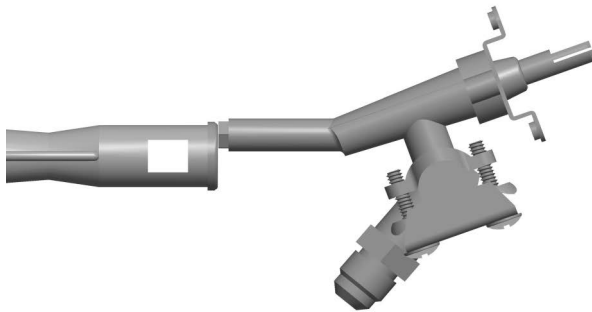

Mal

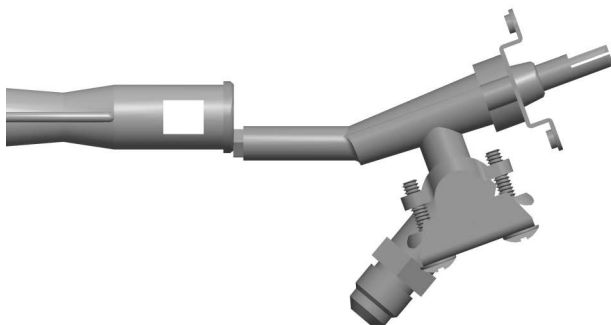

Mal

13

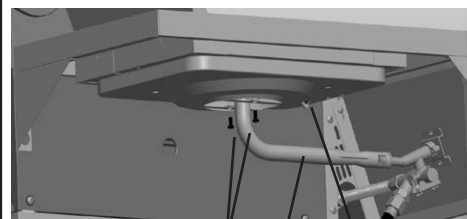
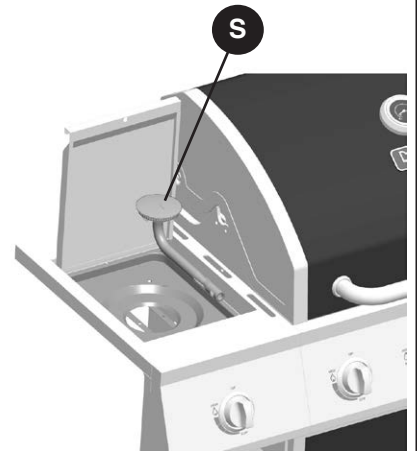

DD Assemblée électrode

S

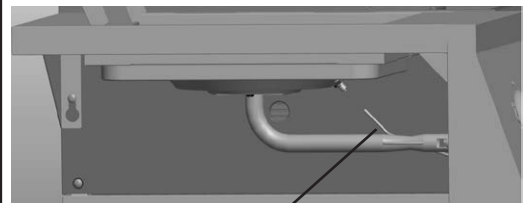

Fil d'allumage du brûleur latéral

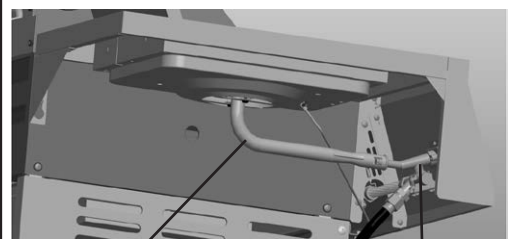



Brûleur latéral
Tube d'entrée de gaz

Brûleur latéral
valve Assemblée

INSTRUCTIONS POUR L'ASSEMBLAGE

14. Insérez 1 paq. M6x12 vis (AA) et 2 paq. M4x12 vis (DD) au cadre du barbecue (C1). Laissez un écart de 4-6mm entre la tête de vis et le cadre du barbecue (C1). Alignez le côté gauche de l'assemblage de la table du brûleur (T) aux 3 vis insérées. Insérez 3 vis (AA) et des rondelles plates (BB) dans les trous du cadre du barbecue (C1) jusqu'à l'assemblage gauche de la table du brûleur (T). Fixez avec 1 vis (DD). Ajustez l'assemblage gauche de la table du brûleur (T), et serrez toutes les vis.

Quincaillerie utilisée

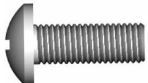
AA	Vis M6 de 12 mm		x 4
BB	Rondelle ordinaire		x 3
DD	Vis M4 de 12 mm		x 3

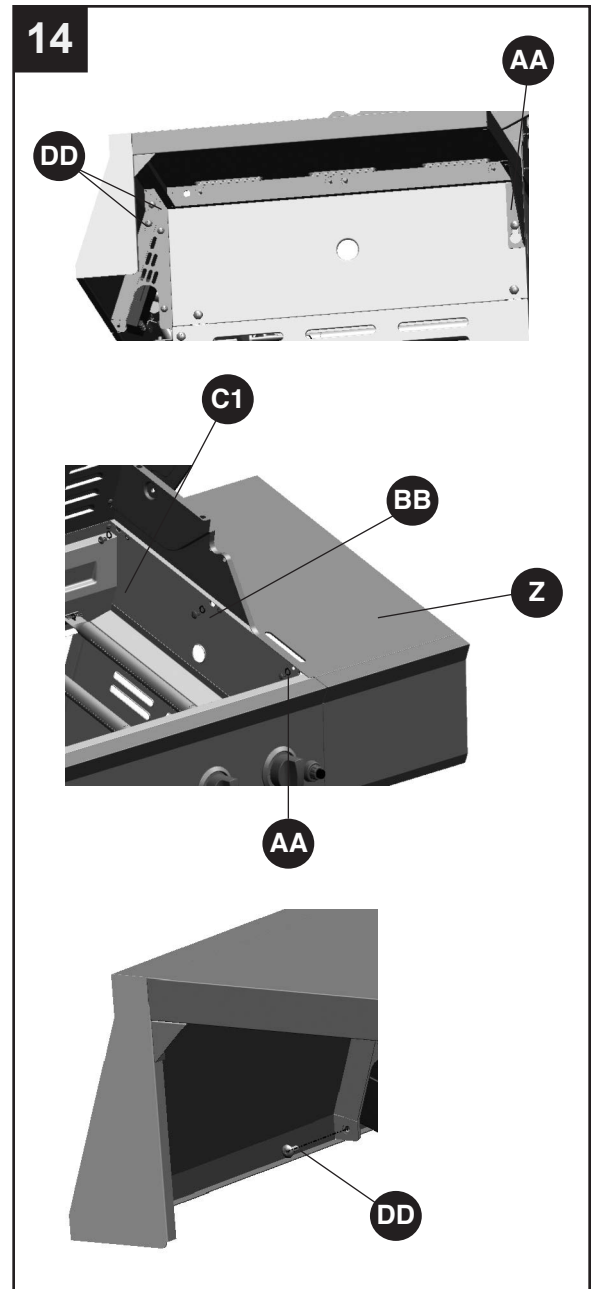

! **AVERTISSEMENT** : IL EST TRÈS IMPORTANT DE S'ASSURER QUE CHACUN DES BRÛLEURS EST COMPLÈTEMENT INSÉRÉ DANS L'ORIFICE DU ROBINET ADJACENT AVANT DE PASSER À L'ÉTAPE 15. LE NON-RESPECT DE CETTE CONSIGNE POURRAIT ENTRAÎNER UN INCENDIE OU UNE EXPLOSION, CE QUI POURRAIT CAUSER DES BLESSURES GRAVES, VOIRE LA MORT. CONSULTEZ LES INSTRUCTIONS DE LA SECTION ENTRETIEN INDICANT LA FAÇON ADÉQUATE DE VÉRIFIER SI LES BRÛLEURS SONT INSÉRÉS.

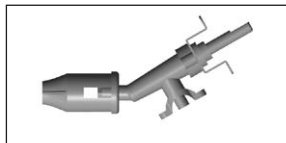

INSTRUCTIONS POUR L'ASSEMBLAGE

15. Ouvrez le couvercle, placez 5 tentes de chaleur (F), 3 grilles de cuisson (E1) et 1 grille de réchauffement (D1) à l'intérieur du cadre du barbecue (C1). Placez la grille de cuisson du brûleur du côté (R) sur la table du brûleur gauche (T). Installez la grille de réchauffement (D1) dans les quatre trous de chaque côté du cadre du barbecue.

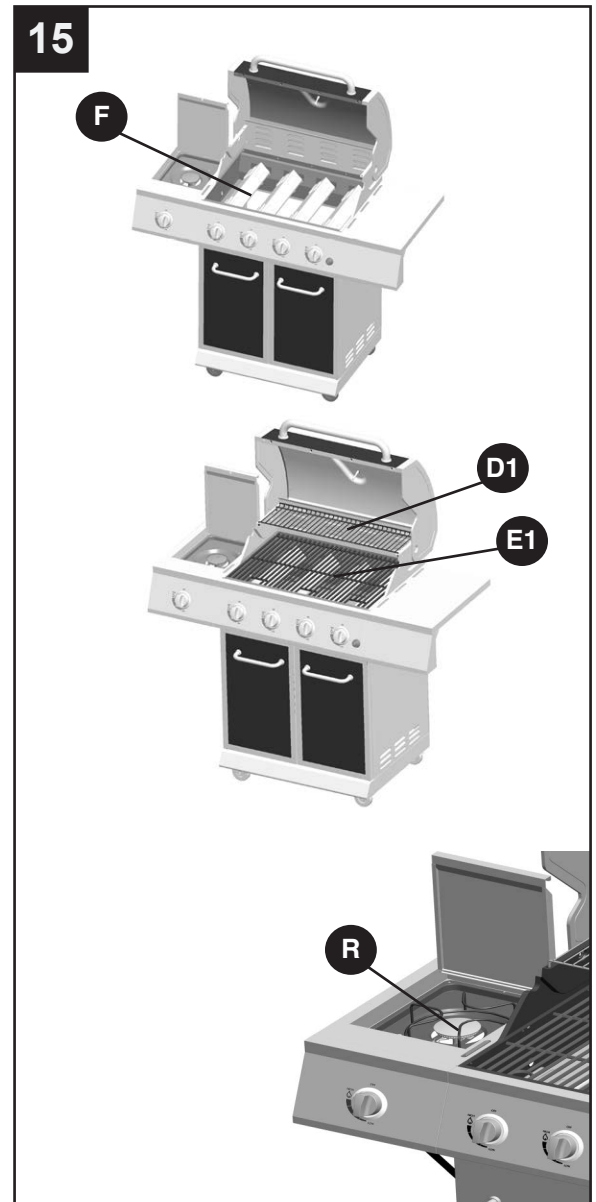

16. Enlevez le capuchon de l'allumeur, insérez pile AA (B) dans l'allumeur. La borne (+) vers l'extérieur. Remettez le capuchon de l'allumeur.

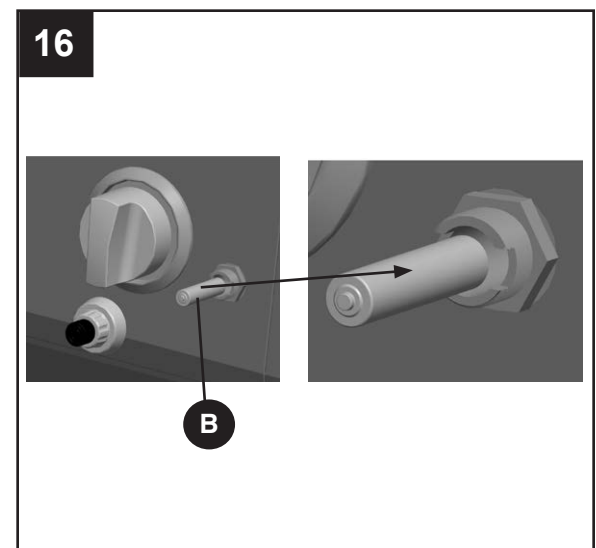

INSTRUCTIONS POUR L'ASSEMBLAGE

17. Installez le plateau à graisse (B1) en le glissant dans le cadre du barbecue par l'arrière. Tel qu'illustré ci-bas. Le long des barres situées juste au-dessous du bas du cadre du barbecue.

NOTE: Faites attention, il ne faut pas glisser le plateau dans le sens opposé. Insérez le récipient à graisse (A1) en le glissant sur la rail sous le plateau de graisse, tel qu'illustré ci-bas.

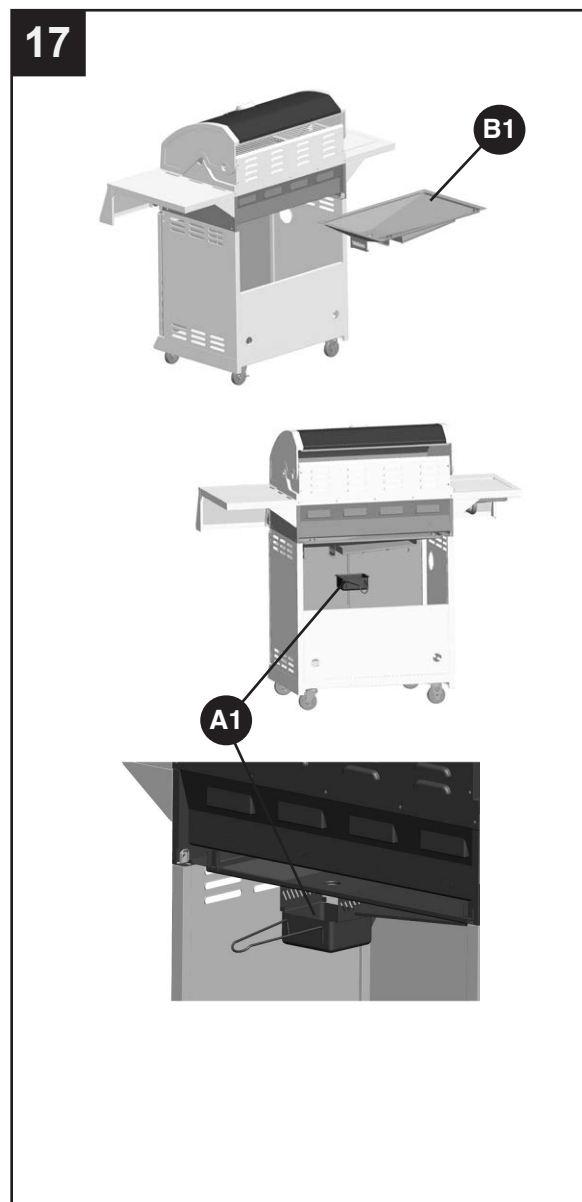

INSTRUCTIONS POUR L'ASSEMBLAGE

18. Ouvrez la porte du charriot (J&K) insérez l'assemblage tuyau/régulateur dans le charriot à travers le trou du panneau gauche du charriot (H). Retirez l'étagère du réservoir (G) du charriot, placez le cylindre de gaz (vendu séparément) sur l'étagère du réservoir (G). Tournez le cylindre de gaz afin de pouvoir installer facilement le raccord tuyau/régulateur à la valve du cylindre GPL. Serrez à la main la bride de fixation tuyau/régulateur à la valve fileté du cylindre de gaz GPL. Serrez le boulon de retenue du cylindre de gaz. Faites glisser l'étagère du réservoir (G) dans le charriot et faites la tenir en plaçant la plaque de verrouillage de la barre de l'étagère du réservoir par dessus et devant l'étagère du réservoir (G).

Entièrement assemblé



Vue avant



Vue arrière

18

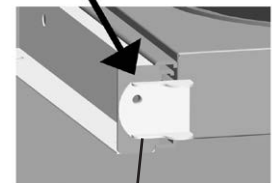
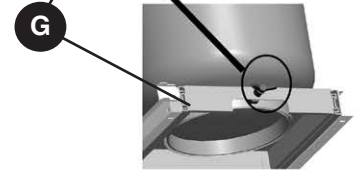

Étagère réservoir de verrouillage ferroviaire plaque



PARRILLA A GAS PL DE 4 FOGONES

Modelo #DGE486BSP/DGE486BSP-D/
DGE486GSP/DGE486GSP-D



C US

ANS Z21.58b- 2012
CSA 1.6b- 2012
Cocina al aire libre
aparatos de gas

ADJUNTE SU RECIBO AQUÍ

Número de serie _____ Fecha de compra _____



¿Preguntas, problemas, piezas faltantes? Antes de volver a la tienda, llame a nuestro Departamento de Servicio al Cliente al 1-877-447-4768, de 8:30 am - 4:30 pm, hora central, de lunes - viernes o envíe un correo electrónico a customerservice@ghpgroupinc.com.



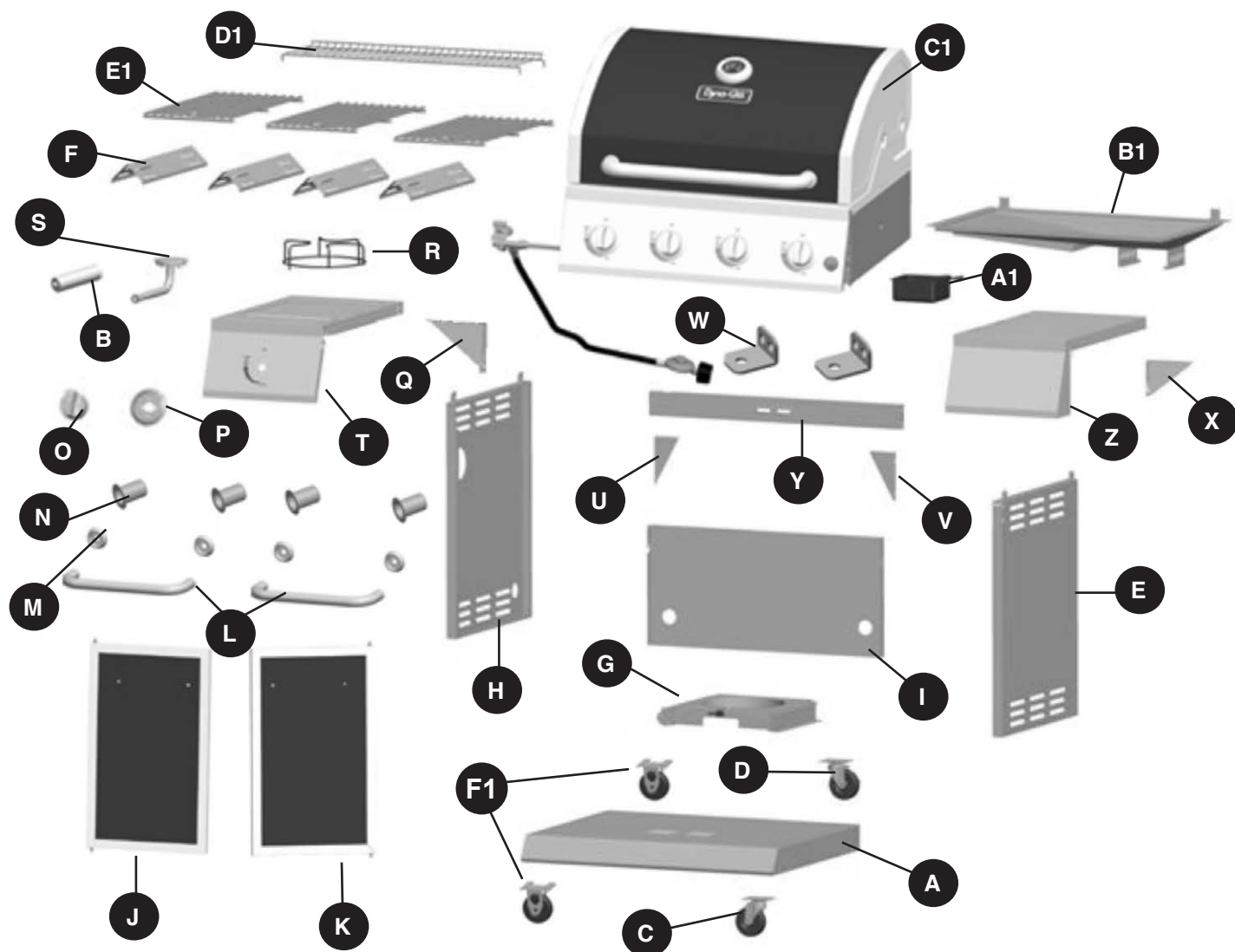

CONTENIDO DEL PAQUETE



PIEZA	DESCRIPCIÓN	CANT.
A	Repisa inferior	1
B	Pila AA (1,5v)	1
C	Rueda Giratoria sin Bloqueo	1
D	Rueda Giratoria con Bloqueo	1
E	Panel Lateral Derecho del Carrito	1
F	Rejilla para Calentar	4
G	Repisa del Tanque	1
H	Carrito Panel Lateral Izquierdo	1
I	Panel trasero del carro	1
J	Asamblea de la puerta izquierda	1
K	Conjunto de la puerta derecha	1
L	Manija de la Puerta	2
M	Bisel de la Manija de la Puerta	4
N	Unión de la Manija de la Puerta	4
O	Perilla control del quemador lateral	1
P	Perilla del quemador lateral del bisel	1

PIEZA	DESCRIPCIÓN	CANT.
Q	Soporte de la Mesa Fogón lado Izquierdo	1
R	Parrilla de Cocción del Fogón Lateral	1
S	Quemador lateral de montaje	1
T	Lateral Izquierdo mesa de montaje	1
U	Soporte izquierdo - Brace Puerta	1
V	Derecho Support - Brace Puerta	1
W	Soporte para el Pin de la Puerta	2
X	Soporte la Mesa del Lado Derecho	1
Y	Abrazadera la Puerta Frontal Superior	1
Z	Ensamble de Mesa del Lado Derecho	1
A1	Taza de la Grasa	1
B1	Bandeja para la Grasa	1
C1	Cuerpo de la Parrilla	1
D1	Rejilla para Calentar	1
E1	Parrilla de Cocción	3
F1	Rueda direccional	2

ADITAMENTOS (se muestran en tamaño real)

				
Tornillo M6x12	Tornillo M6x12	Arandela lisa	Arandela de Resorte M6	Tornillo M4x12 Screw
Qty. 41	Qty. 4	Qty. 26	Qty. 16	Qty. 28
NOTA: Aditamento (AA) preensamblado en la manija de la puerta				

PREPARACION

Antes de comenzar a ensamblar el producto, asegurese de tener todas las piezas. Compare las piezas con la lista del contenido del paquete de la pagina anterior y los aditamentos que aparecen arriba. No intente ensamblar el producto si falta alguna pieza o si estas estan danadas. Póngase en contacto con el Departamento de Servicio al Cliente para obtener piezas de repuesto.

Tiempo estimado de ensamblaje: 50 minutos con 2 personas.

Herramientas necesarias para el ensamblaje y la prueba de fugas (no se incluyen):
Destornillador Phillips, botella con atomizador

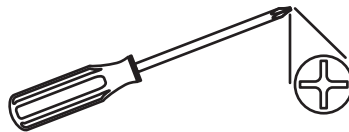

⚠ PRECAUCION

ESTA UNIOAD ES PESADA. SE NECESITAN DOS PERSONAS PARA UN ENSAMBLAJE SEGURO.

Se requieren dos personas para un ensamblaje segura. Algunas partes pueden presentar bordes filosos. Utilice guantes de pratección si es necesario. Lea y siga todas las indicaciones de seguridad, advertencias, instrucciones de ensamblaje, usa y cuidado antes de ensamblar y usar.

INSTRUCCIONES DE ENSAMBLAJE

1. Acople las ruedas, incluyendo 2 ruedas direccionales (F1) las 1 de dirección (B), una rueda giratoria sin bloqueo (C), una rueda giratoria con bloqueo (D), a la repisa inferior (A) mediante 4 tornillos M6 (AA), arandelas planas (BB) y arandelas de resorte (CC) como se muestra en el diagrama inferior.

Aditamentos utilizados

AA	M6x12 Tornillo		x 16
BB	Arandela Lisa		x 16
CC	Arandela de Resorte		x 16

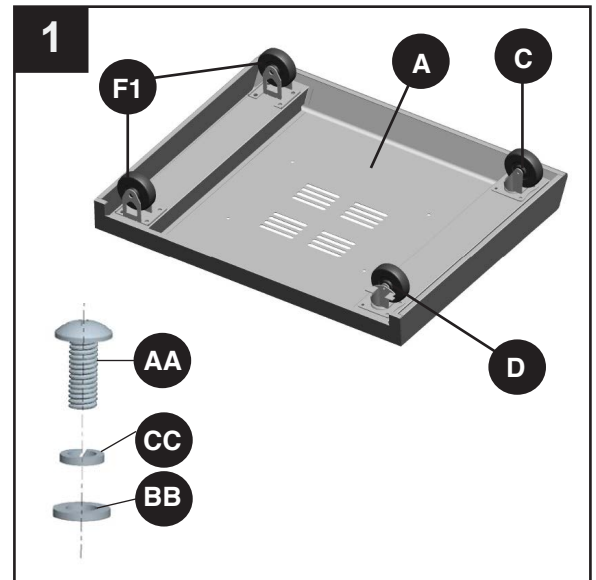

2. Inserte 4 tornillos (AA) dentro de los huecos en la repisa inferior (A), dejando una separación de 4-6mm desde la cabeza del tornillo a la repisa inferior (A). Acople el panel del lado izquierdo del carrito (H) colocando el hueco tipo llave del panel sobre las cabezas de los tornillos (AA) del lado izquierdo de la repisa inferior (A); deslice el panel del lado izquierdo del carrito (H) de tal forma que la cabeza del tornillo esté sobre la parte más pequeña del hueco tipo llave. Enrosque el tornillo (AA) y apriételo pero no completamente por ahora. Repita lo mismo con el panel del lado derecho del carrito (E).

Aditamentos utilizados

AA	M6x12 Tornillo		x 4
-----------	----------------	---	-----

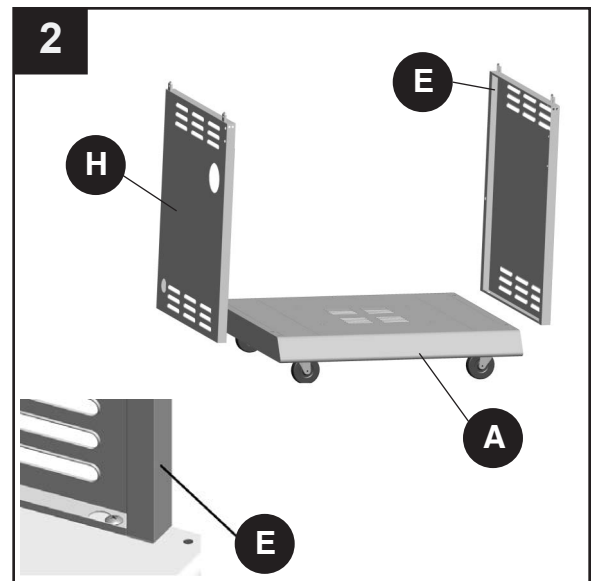

INSTRUCCIONES DE ENSAMBLAJE

3. Inserte un tornillo (AA) dentro de los huecos posteriores de los paneles de los lados izquierdo y derecho del carrito (H&E), dejando 4-6mm de separación desde la cabeza del tornillo a los paneles laterales (H&E). Acople el panel posterior del carrito (I) deslizándolo los huecos tipo llave en el panel posterior del carrito sobre los tornillos insertados y luego empuje con fuerza. Asegure el panel posterior del carrito (I) a la repisa inferior (A) utilizando 3 tornillos (AA). Apriete los 2 tornillos de los paneles laterales (H&E).

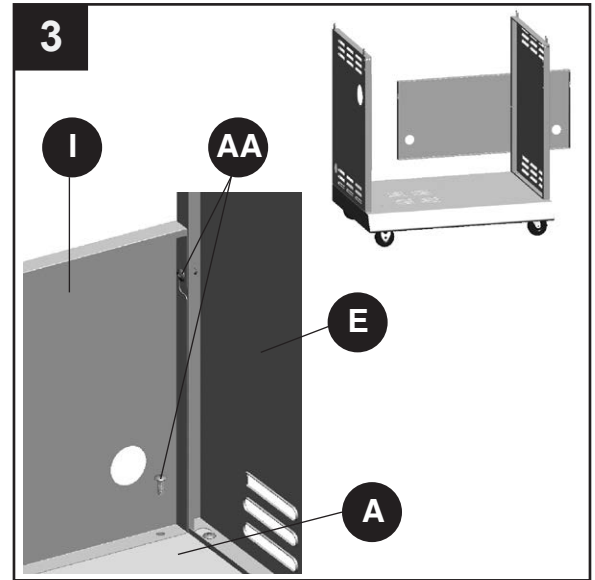

Aditamentos utilizados



4. Alinie la abrazadera de la puerta frontal superior (Y) a los huecos 1 en el panel del lado izquierdo del carrito (H). Asegure la abrazadera de la puerta frontal superior a 2 usando 2 tornillos (AA). Repita el proceso asegurando la abrazadera de la puerta frontal superior (Y) al panel del lado derecho del carrito (E).

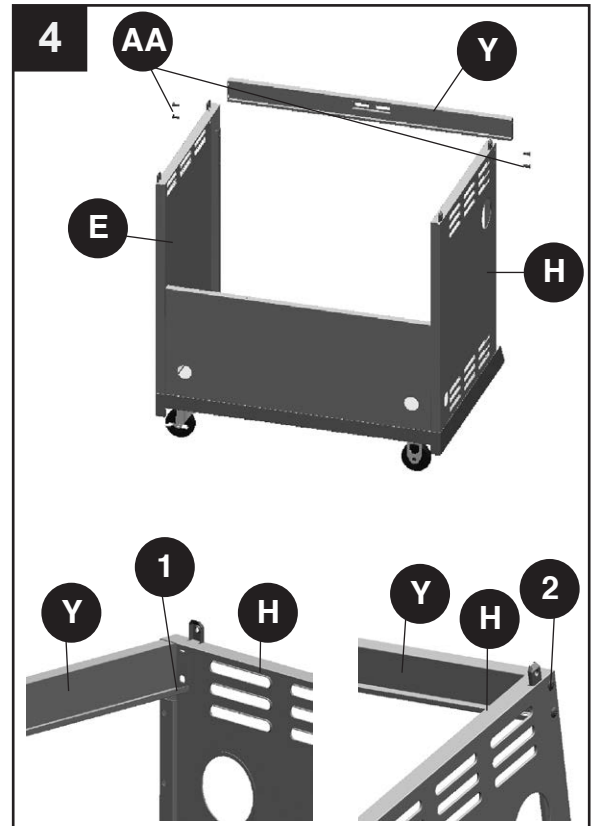

Aditamentos utilizados



INSTRUCCIONES DE ENSAMBLAJE

5. Inserte 2 tornillos (DD) en el borde izquierdo de la abrazadera de la puerta frontal superior (Y) pero no los apriete. Deje 4-6mm de separación desde la cabeza del tornillo a la parte inferior de la abrazadera de la puerta frontal superior (Y). Acople el soporte izquierdo de la abrazadera de la puerta frontal superior (U) a los tornillos insertados. Asegúrelo con 2 tornillos adicionales (DD) y apriete los 4 tornillos (DD). Repita lo mismo con el soporte derecho de la abrazadera de la puerta frontal superior (V).

Aditamentos utilizados

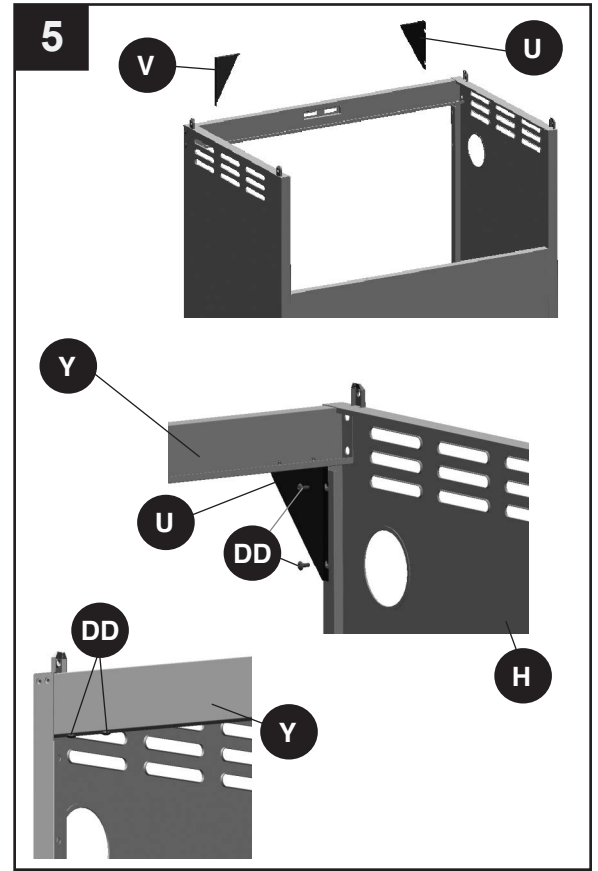

6. Retire los 2 tornillos previamente acoplados (AA) y la unión (N) de la manija de la puerta (L). Inserte las 2 uniones de la puerta (N) dentro de los huecos localizados en la parte posterior del ensamblaje de la puerta (J). Inserte 2 tornillos (AA) dentro de la unión de la manija de la puerta (N), a través de los biselados de la manija de la puerta (M) y de los huecos roscados en las manijas de la puerta (L). Apriete los tornillos como se muestra en la figura inferior. Repita lo mismo con el ensamblaje de la puerta derecha (K).

Aditamentos utilizados

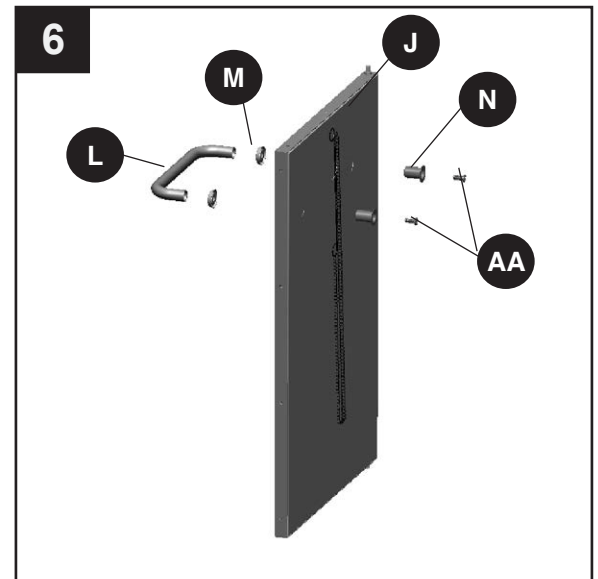

INSTRUCCIONES DE ENSAMBLAJE

7. Inserte el eje inferior del ensamble de la puerta izquierda (J) dentro del hueco (1) de la repisa inferior. Inserte el eje superior del ensamble de la puerta izquierda (J) dentro del hueco del soporte para el pin de la puerta (W); asegure el soporte para el pin de la puerta (W) al panel del lado izquierdo del carrito (H) utilizando 2 tornillos (DD). Repita lo mismo con el ensamble de la puerta derecha (K).

Aditamentos utilizados

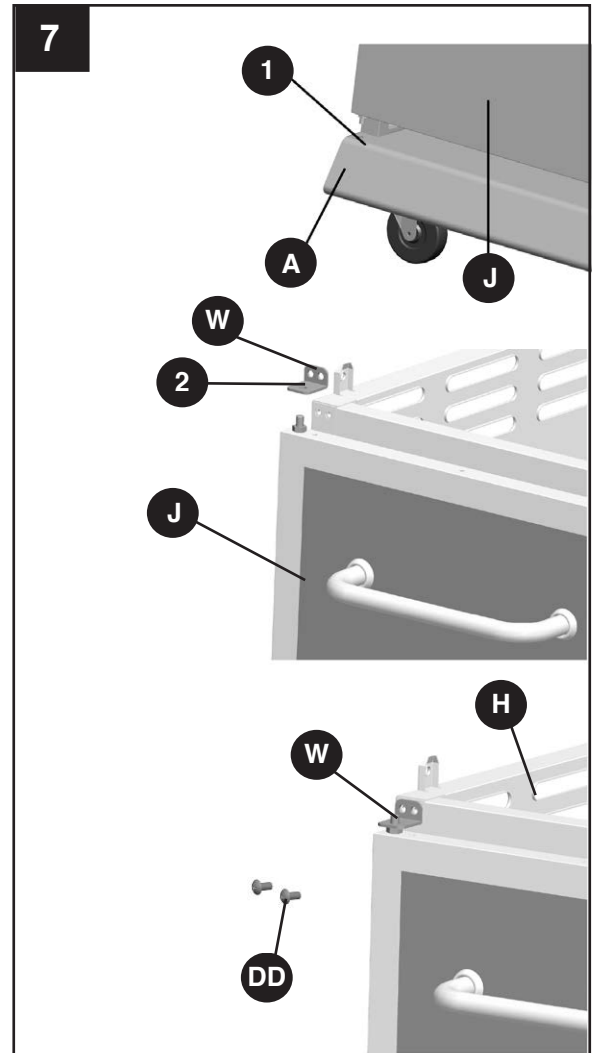

8. Coloque con mucho cuidado la repisa del tanque (G) sobre la repisa inferior (A). Asegure la parte derecha de la repisa del tanque (G) a la repisa inferior (A) utilizando 2 tornillos (DD); apriete los tornillos. Repita lo mismo para asegurar la parte izquierda de la repisa del tanque (G).

Aditamentos utilizados

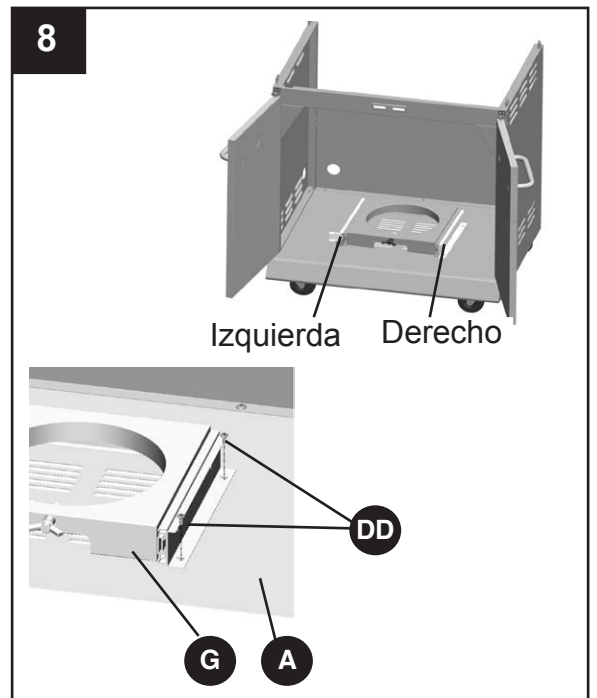

INSTRUCCIONES DE ENSAMBLAJE

9. Coloque con mucho cuidado el cuerpo de la parrilla (C1) en los paneles de los lados izquierdo y derecho del carrito (H&E). Ajuste el cuerpo de la parrilla (C1) de tal forma que los huecos en el cuerpo de la parrilla (C1) estén alineados con los huecos en las pestañas de los paneles laterales del carrito (H&E).
 NOTA: Asegúrese de que el ensamble de manguera/regulador de gas quede por fuera del carrito. Asegure el cuerpo de la parrilla (C1) utilizando 2 tornillos (AA) y arandelas planas (BB) en cada lado.

Aditamentos utilizados

- | | | | |
|-----------|----------------|---|-----|
| AA | M6x12 Tornillo |  | x 4 |
| BB | Arandela lisa |  | x 4 |

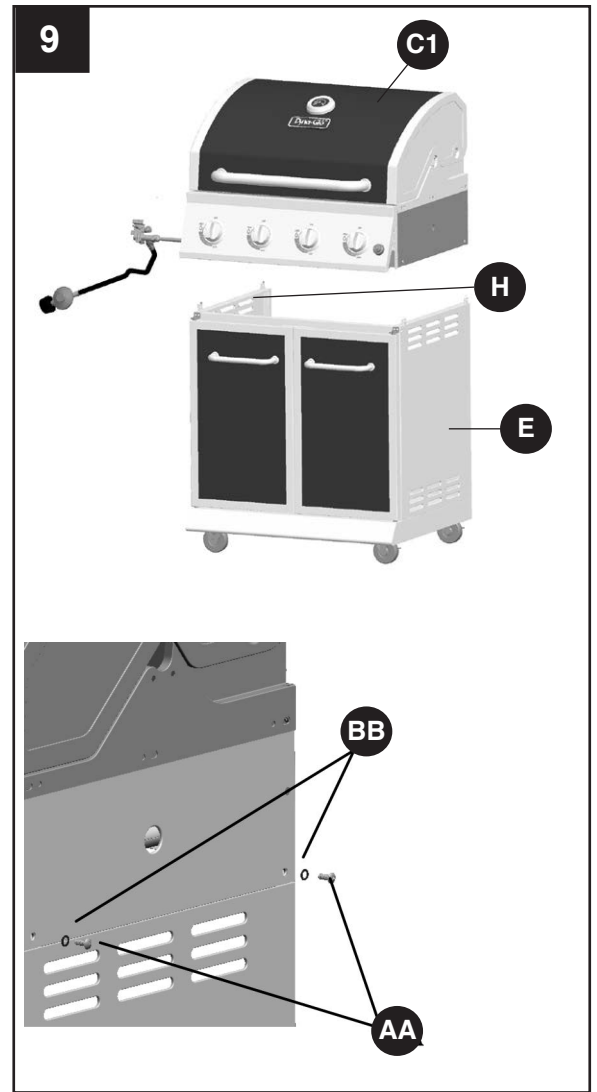

10. Asegure el soporte de la mesa del fogón del lado izquierdo (Q) al ensamble de la mesa del fogón del lado izquierdo (T) mediante 2 tornillos (DD).

Asegure el soporte de la mesa del lado derecho (X) al ensamble de la mesa del lado derecho (Z) utilizando 2 tornillos (DD).

Aditamentos utilizados

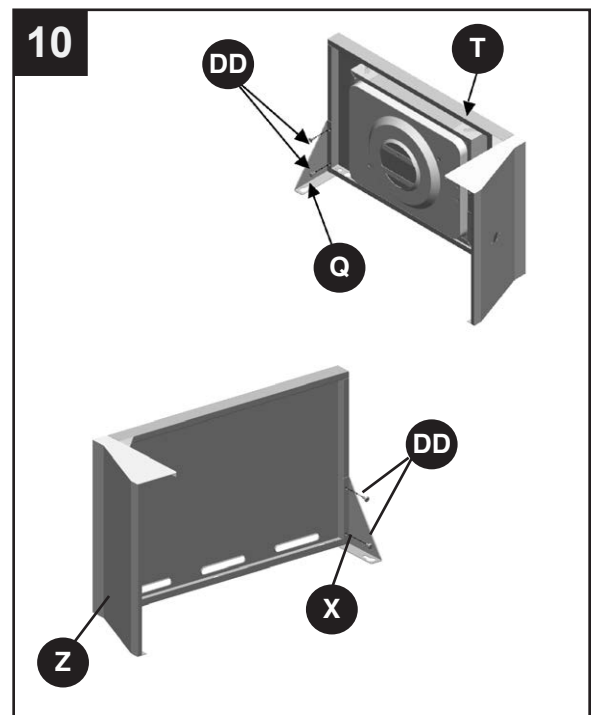

- | | | | |
|-----------|----------------|---|-----|
| DD | M4x12 Tornillo |  | x 4 |
|-----------|----------------|---|-----|



INSTRUCCIONES DE ENSAMBLAJE

11. Inserte 1 tornillo M6x12 (AA) y 2 tornillos M4x12 (DD) al cuerpo de la parrilla (C1), dejando una separación de 4-6mm desde la cabeza del tornillo al cuerpo de la parrilla (C1). Alíne el ensamble de la mesa del fogón del lado izquierdo (T) a los 3 tornillos insertados. Inserte 3 tornillos (AA) con arandelas planas (BB) a partir de los huecos del cuerpo de la parrilla (C1) hacia el ensamble de la mesa del fogón del lado izquierdo (T). Asegure utilizando 1 tornillo (DD). Ajuste correctamente el ensamble de la mesa del fogón del lado izquierdo (T) y luego apriete todos los tornillos.

Aditamentos utilizados

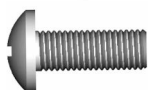
AA	M6x12 Tornillo		x 4
BB	Arandela lisa		x 3
DD	M4x12 Tornillo		x 3

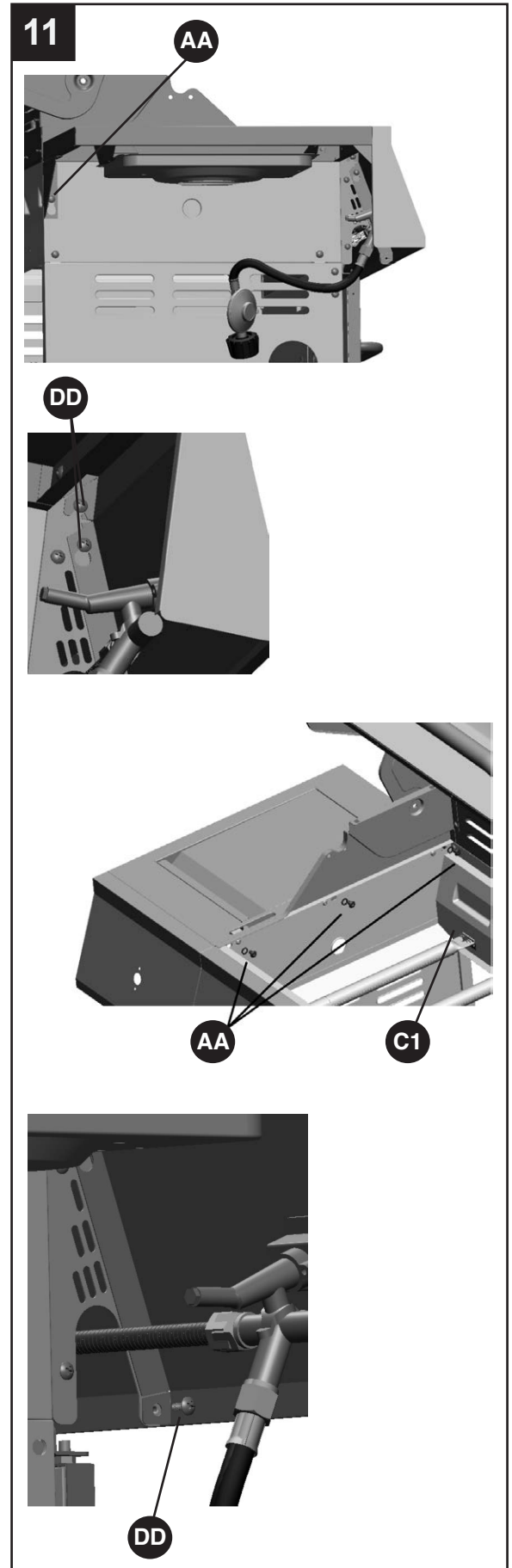

INSTRUCCIONES DE ENSAMBLAJE

12. Retire premontados 2 tornillos de la soporte en el montaje de la válvula del quemador. Retire la perilla de control (O) del fogón lateral pre-ensamblado y el bisel de la perilla de control del fogón lateral (P), del ensamble de válvula del fogón lateral. Asegure el ensamble de válvula del fogón lateral y el bisel de la perilla de control del fogón lateral (P) a la mesa lateral, colocando el ensamble de válvula del fogón lateral debajo de la mesa lateral, y deslizando el vástago de la válvula a través del hueco en el frente de la mesa lateral, manténgalo en su lugar. Coloque el bisel de la manija de control del fogón lateral (P) sobre el vástago de la válvula por la parte de afuera del frente de la mesa lateral, alineando los huecos en el bisel con los huecos en el ensamble de válvula. Asegúrelo volviendo a colocar los tornillos que se habían retirado previamente. Apriete los tornillos. Deslice la perilla de control del fogón lateral (O) sobre el vástago de la válvula.

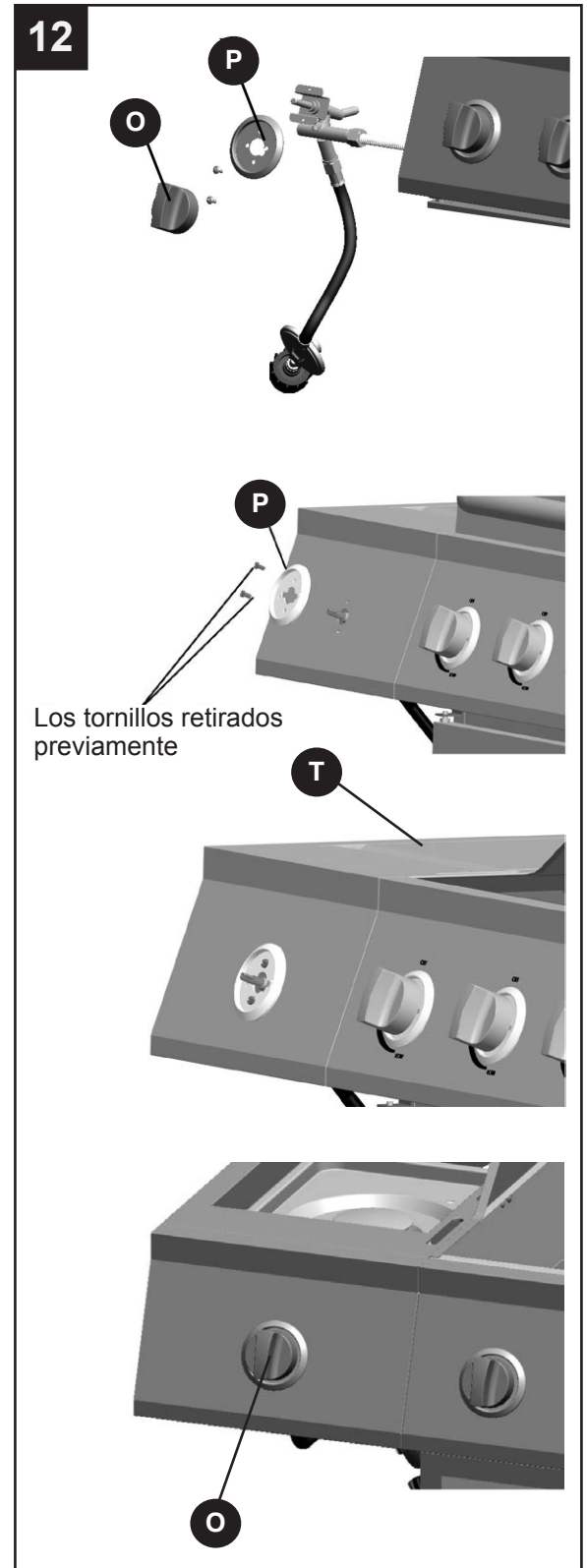

INSTRUCCIONES DE ENSAMBLAJE

13. Asegure el ensamble del fogón lateral (S) al ensamble de la mesa del fogón del lado izquierdo, utilizando 2 tornillos (DD). Asegúrese de que el orificio del fogón lateral esté colocado dentro del tubo de entrada de gas del fogón lateral. Instale el cableado de encendido al ensamble de electrodo.

Aditamentos utilizados

DD M4x12 Tornillo  x 2

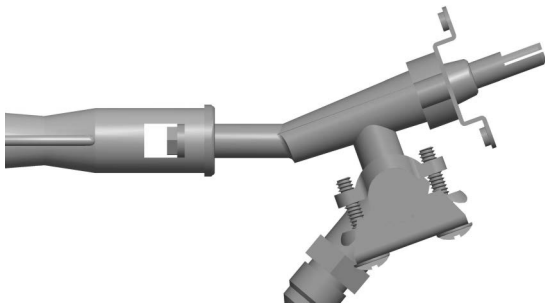

Correcto

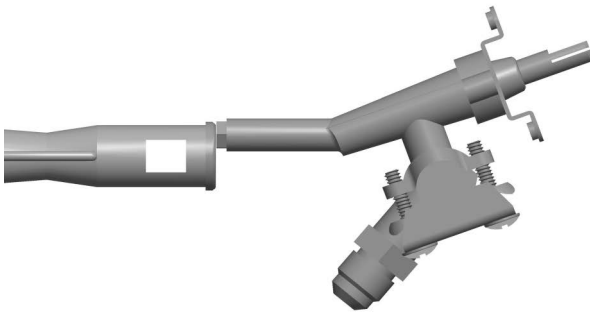

Mal

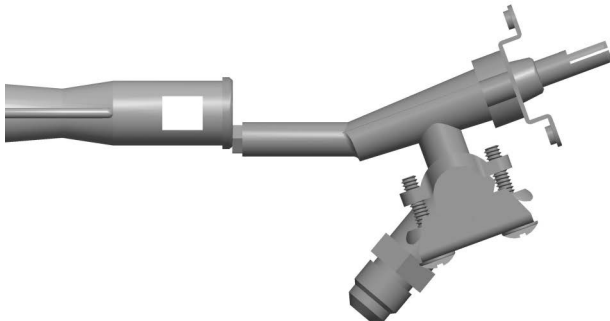

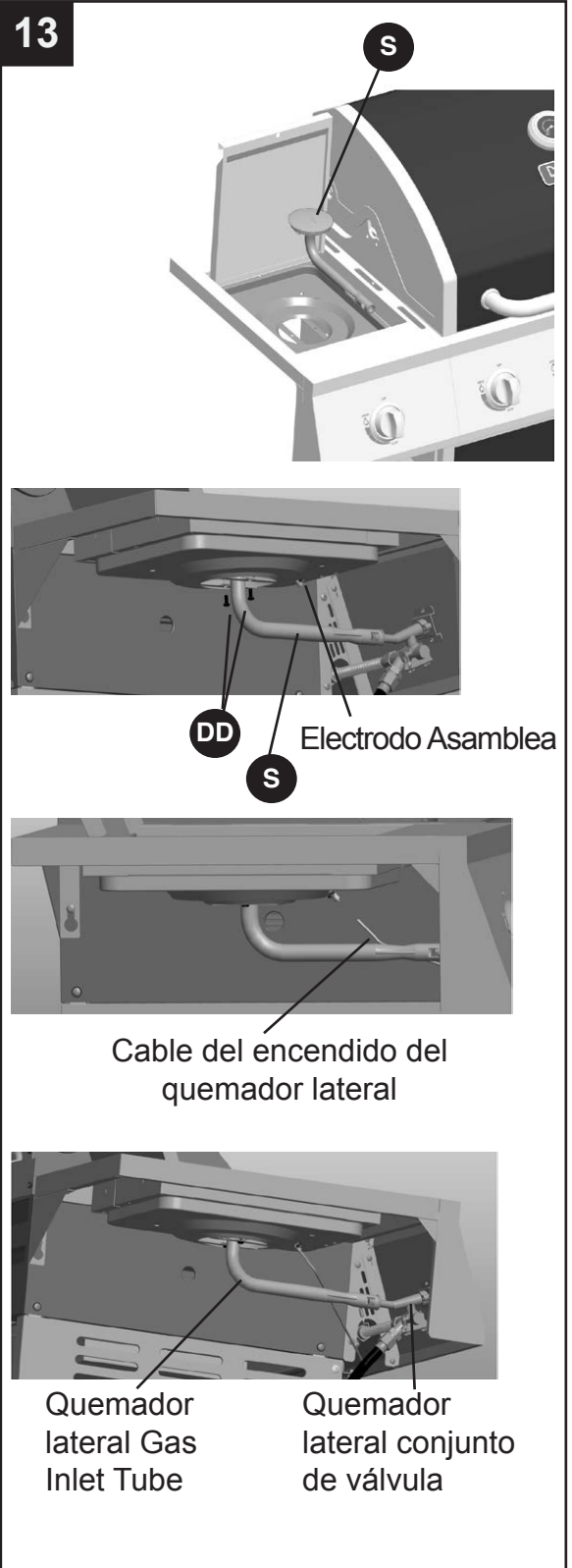

Mal



INSTRUCCIONES DE ENSAMBLAJE

14. .Inserte 1 tornillo M6x12 (AA) y 2 tornillos M4x12 (DD) al cuerpo de la parrilla (C1), dejando una separación de 4-6mm desde la cabeza del tornillo al cuerpo de la parrilla (C1). Alíne el ensamble de la mesa del lado derecho (Z) con los 3 tornillos insertados. Inserte 3 tornillos M6x12 (AA) con arandelas planas (CC) desde los huecos del cuerpo de la parrilla (C1) hacia el ensamble de la mesa del lado derecho (Z). Asegure el ensamble de la mesa del lado derecho (Z) utilizando 1 tornillo M4x12 (DD). Ajuste correctamente el ensamble de la mesa del lado derecho (Z) y luego apriete todos los tornillos.

Aditamentos utilizados

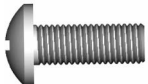
AA	M6x12 Tornillo		x 4
BB	Arandela lisa		x 3
DD	M4x12 Tornillo		x 3

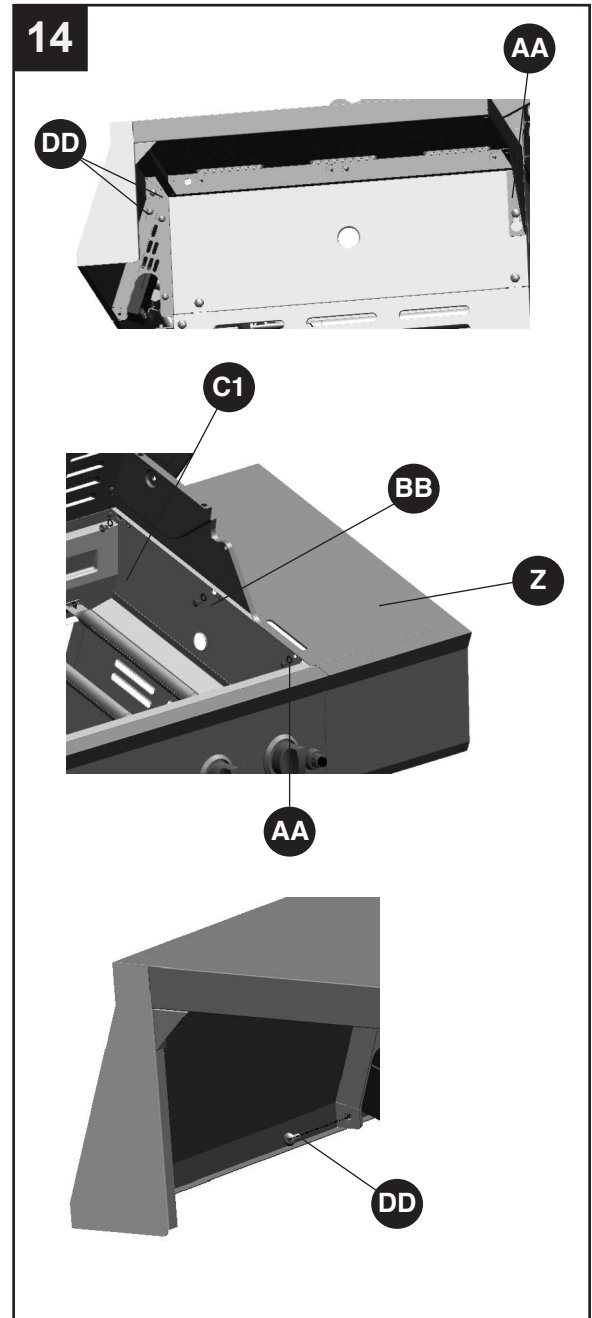

- !** ADVERTENCIA: ES MUY IMPORTANTE VERIFICAR Y ASEGURARSE DE QUE TODOS LOS QUEMADORES ESTEN COMPLETAMENTE ACOPLADOS CON EL ORIFICIO DE LA VALVULA ADYACENTE ANTES DE FINALIZAR EL PASO 15. NO HACERLO PODRIA PROVOCAR UN INCENDIO O UNA EXPLOSION, LO QUE POSIBLEMENTE CAUSARIA LESIONES GRAVES O LA MUERTE. CONSULTE LAS INSTRUCCIONES DE LA SECCION DE MANTENIMIENTO PARA VERIFICAR CORRECTAMENTE EL ACOPLAMIENTO.

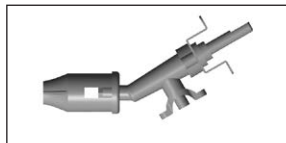

INSTRUCCIONES DE ENSAMBLAJE

15. Abra la tapa, coloque 5 cubiertas de calor (F), 3 parrillas de cocción (E1) y una rejilla para calentar (D1) en el interior del cuerpo de la parrilla (C1). Coloque la parrilla de cocción del fogón lateral (R) sobre la mesa del fogón del lado izquierdo (T). Inserte la rejilla para calentar (D1) dentro de los cuatro huecos localizados en ambos lados del cuerpo de la parrilla.

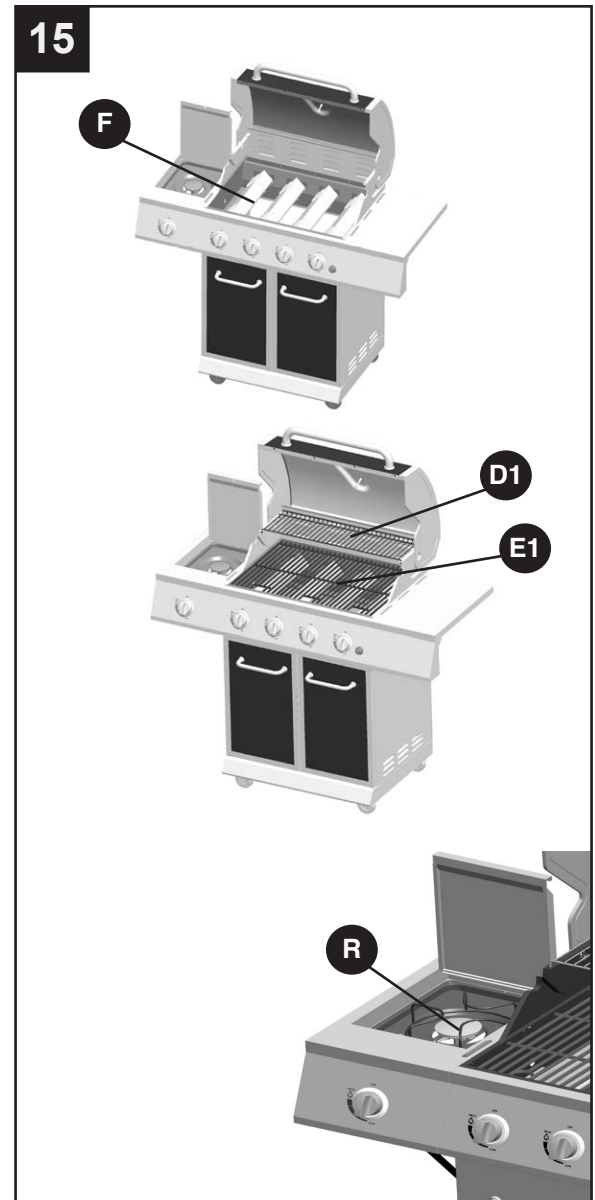

16. Retire la tapa del encendedor, inserte una pila AA (B) dentro del cuerpo del encendedor, con el polo positivo '+' hacia afuera. Vuelva a colocar la tapa del encendedor.

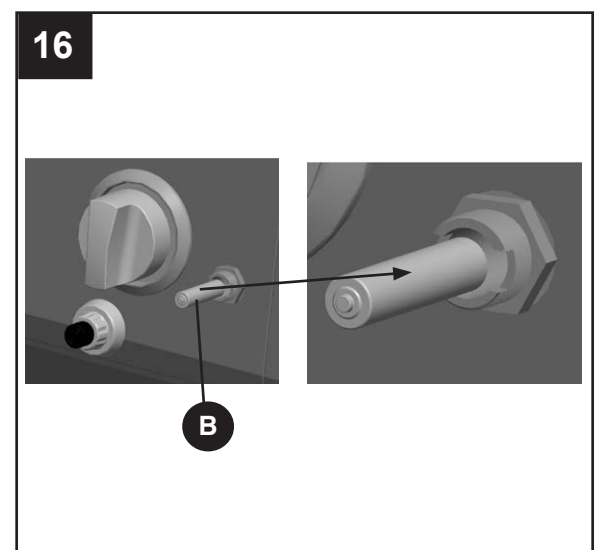

INSTRUCCIONES DE ENSAMBLAJE

17. Coloque la bandeja para la grasa (B1) en posición, deslizando en el cuerpo de la parrilla por la parte de atrás como se muestra en la figura inferior, a lo largo de los rieles ubicados justo debajo de la cara inferior del cuerpo de la parrilla.

NOTA: Fíjese que no vaya a deslizar la bandeja para la grasa por el lado contrario.

Inserte la taza de la grasa (A1) en posición, deslizando sobre el riel en lado inferior de la bandeja para la grasa como se muestra en la figura inferior.

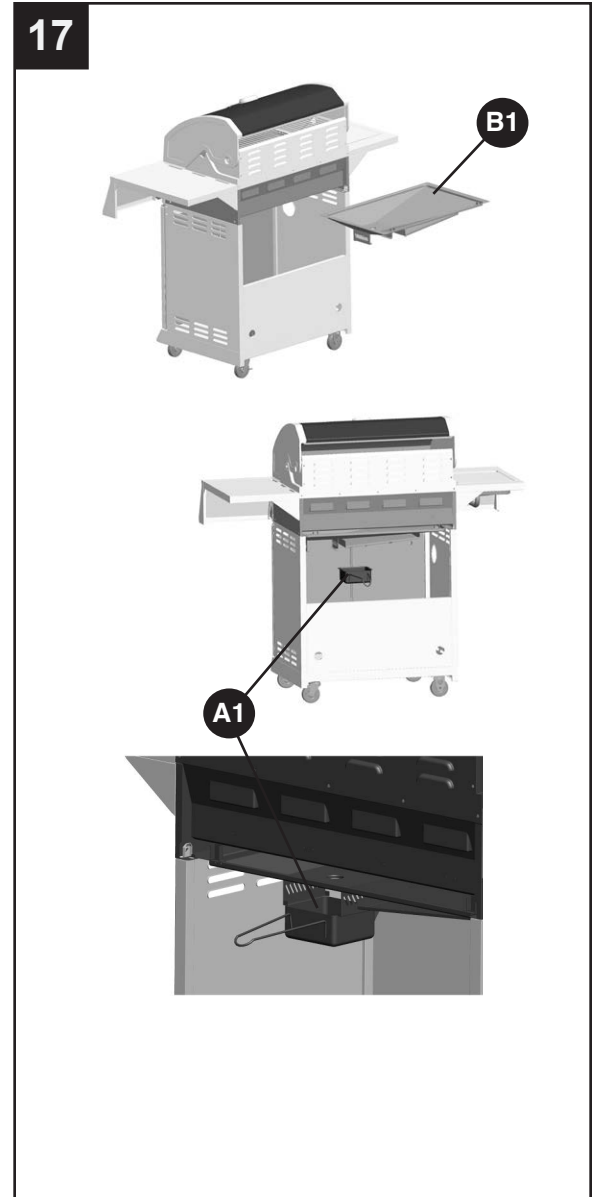

INSTRUCCIONES DE ENSAMBLAJE

18. Abra el ensamblaje de la puerta del carrito (J&K), inserte el ensamblaje manguera/ regulador en el ensamblaje del carrito a través del hueco en el panel del lado derecho del carrito (H). Hale la repisa del tanque (G) fuera del carrito, coloque el cilindro de gas (vendido por aparte) sobre la repisa del tanque (G). Rote el cilindro de gas hasta que el conjunto manguera/regulador pueda ser fácilmente acoplado a la válvula en el cilindro de PL. Apriete a mano el conjunto manguera/ regulador a la válvula roscada del cilindro de gas PL. Apriete la tuerca retenedora del cilindro de gas. Deslice la repisa del tanque (G) de vuelta al carrito y asegúrela en su lugar girando la placa de aseguramiento del riel de la repisa del tanque por encima y en frente de la repisa del tanque (G).

Completamente montado



Vista frontal

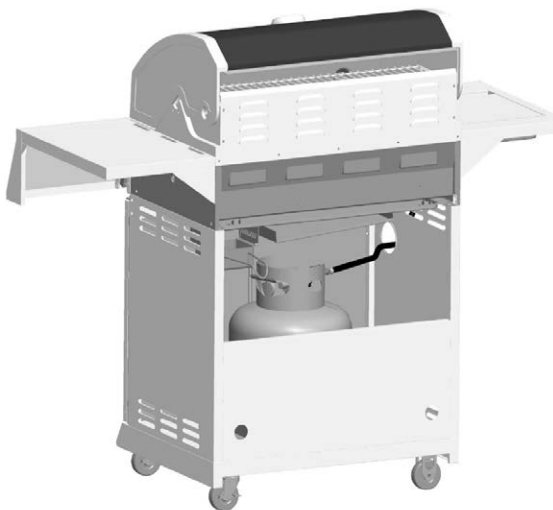

Vista posterior

18

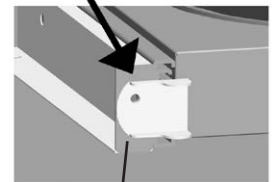
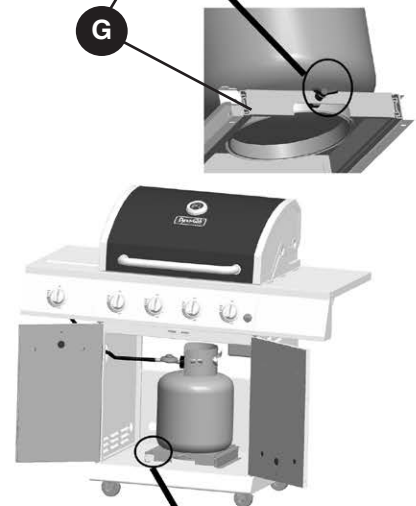

Estante del tanque de ferrocarril placa de bloqueo