

Model 950XLT2

LEAD-FREE*

Double Check Valve Assembly (3/4", 1", 1 1/4", 1 1/2" & 2")

*This product contains a weighted average lead content less than 0.25% for wetted surfaces.

*Certified to NSF/ANSI 61-G



□ Installation □ Testing □ Maintenance Instructions

INSTALLATION INSTRUCTIONS

CAUTION: Installation of Backflow Preventers must be performed by qualified, licensed personnel. The installer should be sure the proper device has been selected for the particular installation. Faulty installation could result in an improperly functioning device.

ZURN WILKINS Model 950XLT2 Double Check Valve assemblies are for use on potable water lines where a health hazard does not exist in the event of a backflow situation.

Damage to the device could result wherever water hammer and/or water thermal expansion could create excessive line pressure. Where this could occur, shock arresters, check valves and/or pressure relief valves should be installed downstream of the device.

If installation is in a pit or vault, the Backflow Preventer must never be submerged in water because this could cause a cross-connection. Make sure that the pit or vault always remains dry by providing ample drainage.

1. Before installing a Model 950XLT2 Backflow Preventer, flush the line thoroughly to remove all debris, chips and other foreign matter. If required, a lead-free strainer should be placed upstream of the Backflow Preventer. **CAUTION:** Do not use a lead-free strainer in seldom used emergency waterlines such as fire lines.
2. Provide adequate space around the installed unit so that the test cocks will be accessible for testing and servicing.
3. Install valve at least 12 inches above surrounding flood level.
4. Always consult local codes for installation methods, approvals and guidance.

PLACING THE MODEL 950XLT2 IN SERVICE

1. Start with both shut-off valves closed. Slowly open the inlet shut-off valve until the backflow preventer is completely pressurized.
2. When the unit has been pressurized, vent any trapped air by slightly opening each of the four test cocks.
3. Slowly open the downstream shut-off valve. The Model 950XLT2 Double Check Valve assembly is now in service.
4. After the Model 950XLT2 has been properly installed, test the device (see "TEST PROCEDURES"). If the device fails the test, remove the first and second check valves and thoroughly flush the device. Clean rubber and seats of all debris and place unit back in service.

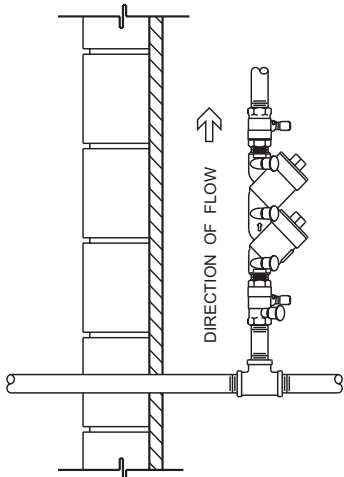

VERTICAL INSTALLATION

Vertical installation is acceptable in applications where inlet and outlet piping are flowing vertically upwards. All the basic installation instructions apply to such installations. Consult factory for approval status.

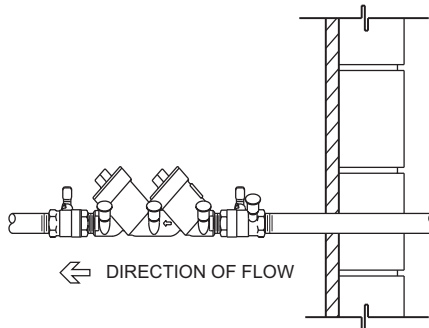

INDOOR INSTALLATION

Indoor installation is preferred in areas that are subject to freezing conditions. All the basic installation instructions apply to such installations.

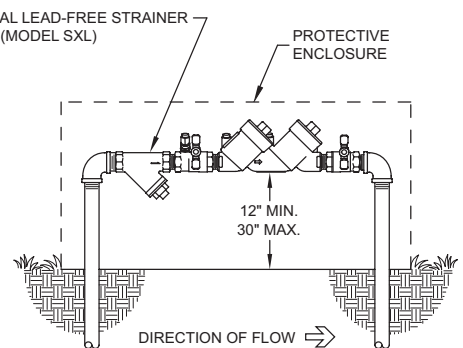
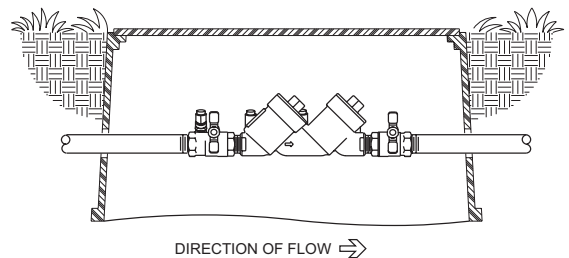

OUTDOOR INSTALLATION

The Model 950XLT2 Backflow Preventer may be installed outdoors only if the device is protected against freezing conditions. Exposure to freezing conditions will result in improper function or damage to the device. The installation location must be kept above 32°F. All the basic installation instructions apply.



Testing Procedures

MODEL 950XLT2 DOUBLE CHECK VALVE ASSEMBLY

Equipment Required: Differential pressure gauge test kit.

TEST NO. 1 - TIGHTNESS OF #1 CHECK VALVE

REQUIREMENT:

The static pressure drop across check valve #1 shall be at least 1.0 psid. If test cock #3 is not at the highest point of the check valve body, then a vertical tube must be installed on test cock #3 so that it rises to the top of the check valve body.

PROCEDURE:

1. Slowly open all 4 test cocks to remove any foreign material and attach fittings.
2. Attach hose from the high side of the test kit to the #2 test cock.
3. Open test cock #2 and bleed all air from the hose and gauge by opening the high side bleed needle valve. Close high side bleed needle valve. If a tube is attached to test cock #3, open test cock #3 to fill the tube. Close test cock #3. Close #2 shut-off valve then close the #1 shut-off valve.
4. Hold gauge at same level as test cock #3 or water level in tube. Slowly open test cock #3. Record the static pressure drop across check valve #1 after gauge reading stabilizes and water stops running out of test cock #3.
5. Close all test cocks, open shut-off valve #1 and remove test equipment.

TEST NO. 2 - TIGHTNESS OF #2 CHECK VALVE

REQUIREMENT:

The static pressure drop across check valve #2 shall be at least 1.0 psid. If test cock #4 is not at the highest point of the check valve body, then a vertical tube must be installed on test cock #4 so that it rises to the top of the check valve body.

PROCEDURE:

1. Attach hose from the high side of the test kit to the #3 test cock.
2. Open test cock #3 and bleed all air from the hose and gauge by opening the high side bleed needle valve. Close high side bleed needle valve. If a tube is attached to test cock #4, open test cock #4 to fill the tube. Close test cock #4. Close #1 shut-off valve.
3. Hold gauge at same level as test cock #4 or water level in tube. Slowly open test cock #4. Record the static pressure drop across check valve #2 after gauge reading stabilizes and water stops running out of test cock #4.
4. Close all test cocks, slowly open shut-off valve #1 & #2 and remove test equipment.

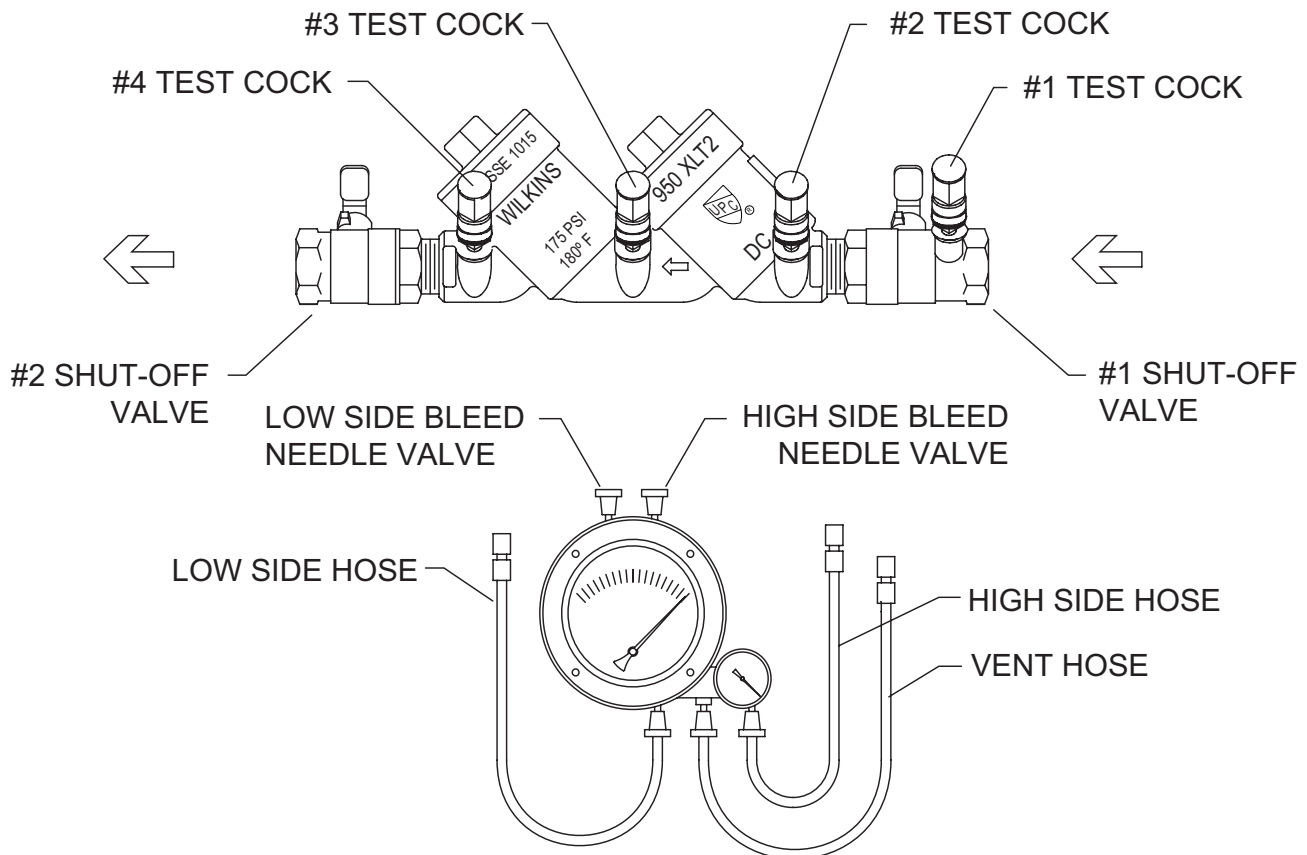

Maintenance Instructions

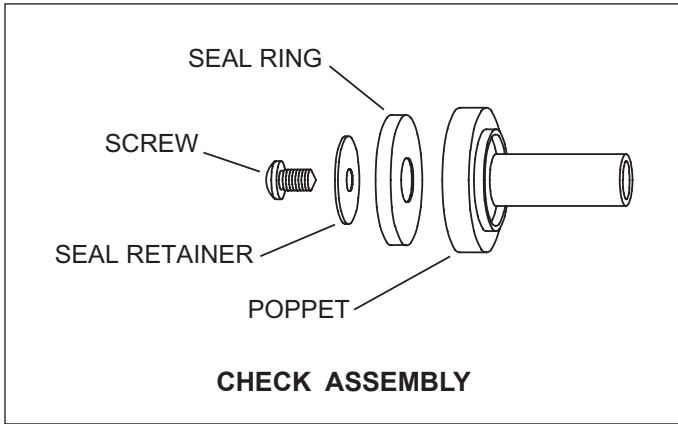

All Model 950XLT2 Double Check Valve Backflow Preventers must be inspected and maintained by licensed personnel at least once a year or more frequently as specified by local codes. Replacement of worn or damaged parts must only be made with genuine "ZURN WILKINS" parts.

GENERAL MAINTENANCE

1. Clean all parts thoroughly with water after disassembly.
2. Carefully inspect rubber seal rings and o-rings for damage.
3. Test unit after reassembly for proper operation (refer to "TESTING PROCEDURES").

SERVICING CHECK VALVES

1. Close inlet and outlet shut-off valves.
2. Open No. 2, No. 3 and No. 4 test cocks to release pressure from valve.
3. Unscrew check valve cover using appropriate sized wrench. **CAUTION: COVER IS SPRING LOADED.** To avoid injury, hold cover down firmly with one hand while unscrewing.
4. Remove cover, spring and poppet assembly.
5. Inspect the rubber seal ring for cuts or embedded debris.
6. To remove seal ring, remove screw and seal retainer.
7. If the reverse side of the seal ring is unused, it is possible to invert the seal ring. This would be considered a temporary solution to fixing a fouled check and should be replaced with a new seal ring as soon as possible.
8. Inspect the valve cavity and seating area. Remove any debris.
9. If necessary, unscrew seat from body and replace with new seat and lightly greased o-ring (For seat removal assistance, contact factory).
10. Reverse the above procedures to reinstall check valve assemblies and access cover, making sure the 3 test cocks remain open.

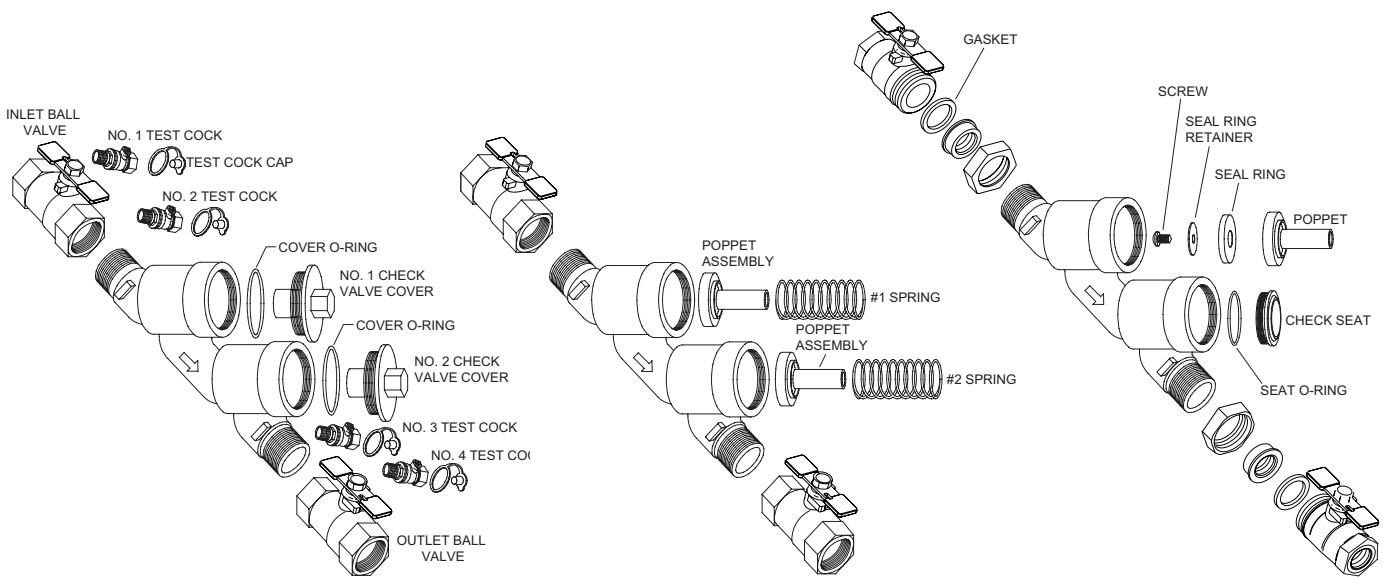

FIGURE 1

FIGURE 2

FIGURE 3
(Shown with optional union ball valves)

Troubleshooting

| <u>PROBLEM</u> | <u>POSSIBLE CAUSES</u> | <u>CORRECTIVE ACTION</u> |
|-------------------------|---|--|
| 1. LEAKING CHECK VALVES | <ol style="list-style-type: none"> 1. Debris on seat or seal ring 2. Damaged seat 3. Damaged seat o-ring | <ol style="list-style-type: none"> 1. Clean seat and seal ring area 2. Replace seat 3. Replace seat o-ring |
| 2. LOW OR NO FLOW | <ol style="list-style-type: none"> 1. Device installed backwards 2. Shut-off valves or valve upstream may not be fully open 3. Low supply pressure | <ol style="list-style-type: none"> 1. Verify flow direction arrow 2. Turn handles counterclockwise 3. Attach pressure gauge to test cock #1 and verify pressure |

Performance Characteristics

MODEL 950XLT2 3/4", 1", 1 1/4", 1 1/2" & 2" (STANDARD & METRIC)

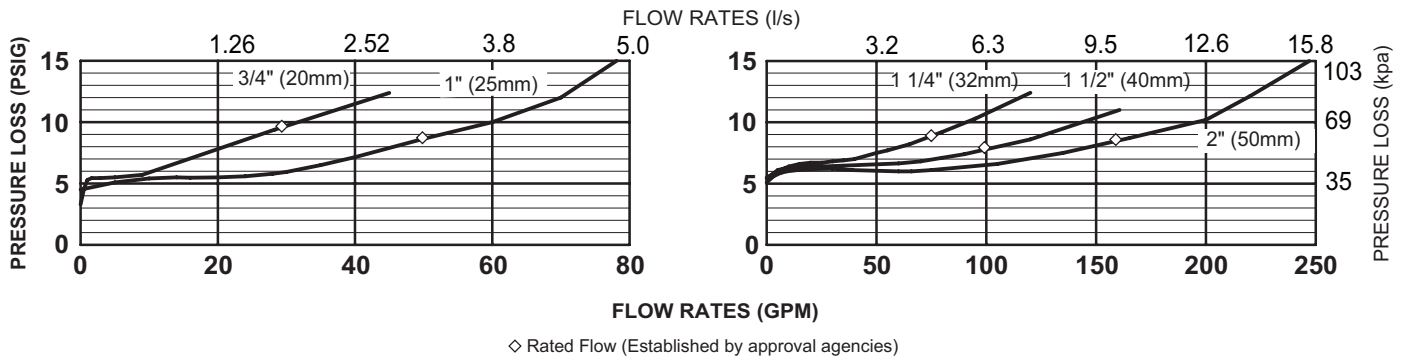

| Capacity thru Schedule 40 Pipe | | | | |
|--------------------------------|----------|------------|-----------|-----------|
| Pipe size | 5 ft/sec | 7.5 ft/sec | 10 ft/sec | 15 ft/sec |
| 1/8" | 1 | 1 | 2 | 3 |
| 1/4" | 2 | 2 | 3 | 5 |
| 3/8" | 3 | 4 | 6 | 9 |
| 1/2" | 5 | 7 | 9 | 14 |
| 3/4" | 8 | 12 | 17 | 25 |
| 1" | 13 | 20 | 27 | 40 |
| 1 1/4" | 23 | 35 | 47 | 70 |
| 1 1/2" | 32 | 48 | 63 | 95 |
| 2" | 52 | 78 | 105 | 167 |

SPECIFICATIONS

Maximum working water pressure: 175 PSI
 Maximum working water temperature: 180°F
 Hydrostatic test pressure: 350 PSI
 End connections: Threaded ANSI B1.20.1

Proper performance is dependent upon licensed, qualified personnel performing regular, periodic testing according to ZURN WILKINS' specifications and prevailing governmental & industry standards and codes and upon following these installation instructions. Failure to do so releases ZURN WILKINS of any liability that it might otherwise have with respect to that device. Such failure could also result in an improperly functioning device.

Proposition 65 Warning This product contains chemicals known to the State of California to cause cancer or birth defects or other reproductive harm.