

ARLINGTON

DESIGNER COLLECTION

H | S

FEATURES INCLUDE:

- Standard Integral Waste and Overflow
- Towel Bar
- Adjustable Legs



OPTION	ELECTRICAL REQUIREMENTS
Thermal Air	1 15amp - 115V dedicated GFCI

ARLINGTON

DESIGNER COLLECTION

H|S

As SHOWN:

Acrylic Tub

FEATURES SHOWN:

- Towel Bar

AVAILABLE SYSTEMS:

- Soaking tub only
- Thermal Air

Size:

70.40.26

WATER CAPACITY:

90 Gallons

WEIGHT:

150 lbs. Tub Only

180 lbs. Thermal Air

MODEL 7040 DIMENSIONS:

- (L)ength- 70"
- (W)idth- 40"
- (H)eight Finish- 26"
- Back Slope - 26°



ACRYLIC TUB

- Acrylic models finished in 1/8" thick layer of deep lustrous acrylic
- Extra thick reinforced fiberglass
- Slip resistant bottom
- Integral overflow, p-trap located directly below waste

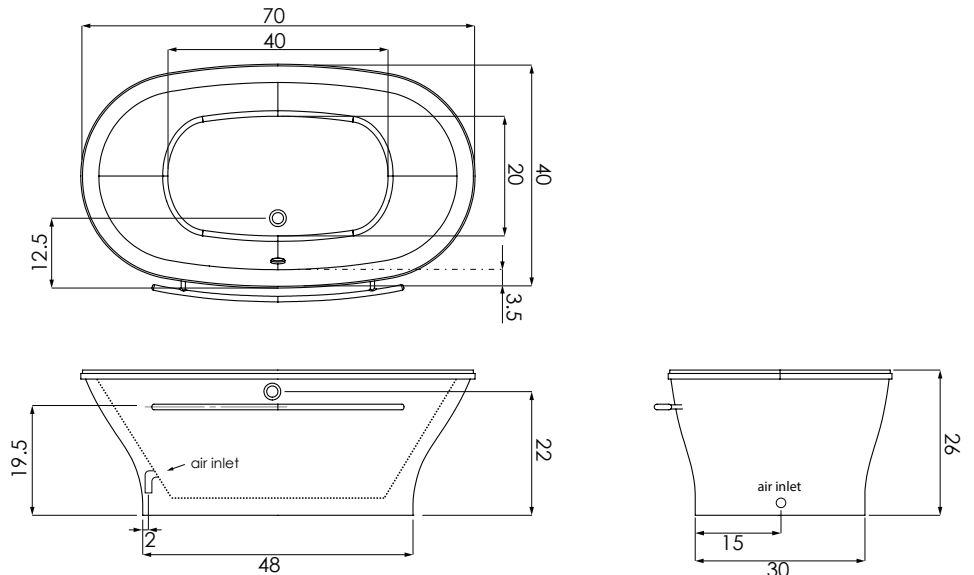

CODES AND COMPLIANCES

Massachusetts code File no: P1-0614-491



HYDRO SYSTEMS
Family Owned And Operated Since 1978

29132 Avenue Paine. Valencia, CA, 91355
661.775.0686 | hydrosystem.com

All specifications and options subject to change without notice please contact a Hydro Systems representative for more information. Certain options or altering the pump/blower location may cause the pump/blower to extend beyond the tub decking. For cutout dimensions wait for unit to arrive. All specifications subject to change without notice.