

# Installation Guide

for EMCO® 1" Aluminum Self-Storing,  
Crossbuck and Fullview Storm Doors



Please Do Not Return Product to Store!

**PLEASE** call the storm door Solution Center at 1-800-933-3626

with any questions regarding installation, mis-cut part replacement, lost part replacement, or anything else related to your storm door purchase.

- If your abilities do not match the requirements of this installation, contact an experienced contractor.
- EMCO has no responsibility in regard to the post-manufactured assembly and installation of EMCO® products.



## PARTS OVERVIEW

Your storm door should contain the following parts:

- 1 Rain Cap
- 2 Door Frame
- 3 Hinge Rail with 3 hinges  
(Hinge Side Z-bar)
- 4 Ventilating Glass panel
- 5 Insect Screen
- 6 Latch Rail  
(Handle Side Z-bar)
- 7 Sweep, vinyl

### Not Shown (all models)

- 8 Hardware Kit, includes
  - Door Mounting screws
  - Handle Set
  - Closer Kit

### Crossbuck and Fullview

#### Not Shown

- 9 Glass Panel
- 10 Insect Screen
- 11 Side Retainer (2)

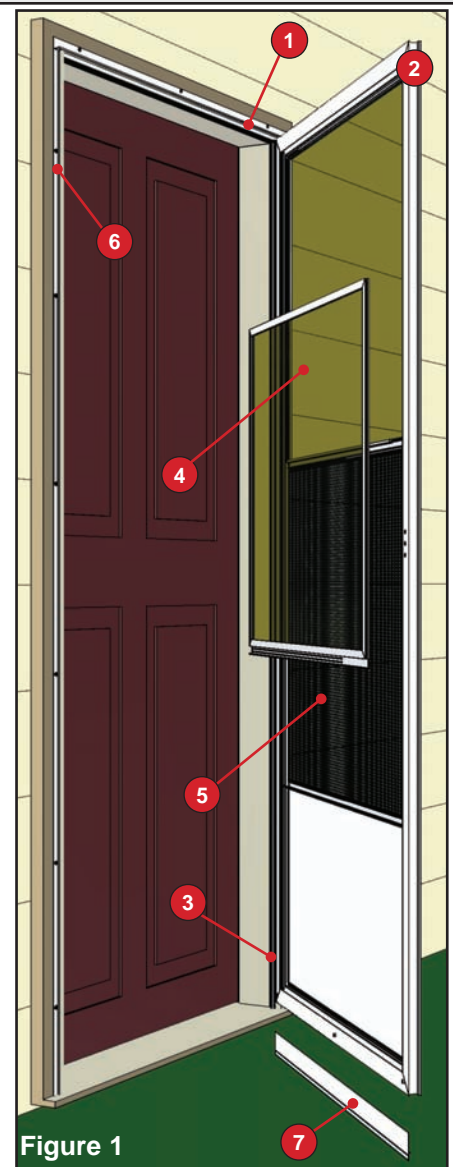
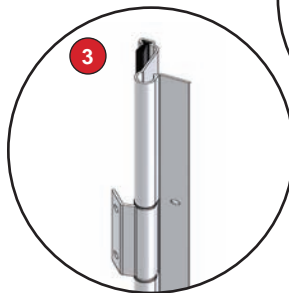
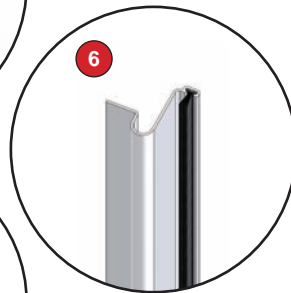
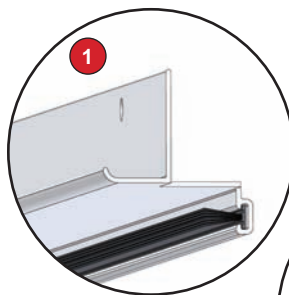

Figure 1

# EMCO®

EMCO Enterprises, Inc., is a wholly owned subsidiary of Andersen Corporation. EMCO manufactures and supports the limited warranties for Andersen® and EMCO® doors. "Andersen", "EMCO" and all other marks where denoted are trademarks of Andersen Corporation. ©2011 Andersen Corporation. All rights reserved.

EMCO Enterprises, Inc.  
PO Box 853  
Des Moines, IA 50306-0853  
Rev 5-2011 7090  
P/N 619232

**SAFETY FIRST - PLEASE READ AND FOLLOW ALL WARNINGS AND CAUTIONS IN THIS GUIDE.**

<b>⚠ WARNING</b> Entry door hardware and handle may become hot when exposed to sunlight.	<b>⚠ WARNING</b> Improper use of hand or power tools could result in injury and/or product damage. Follow equipment manufacturer's instructions for safe operation. Always wear safety glasses.	<b>⚠ WARNING</b> Windows and doors can be heavy. Use safe lifting techniques and a reasonable number of people with enough strength to lift, carry, and install window and door products to avoid injury and/or property damage.	<b>⚠ WARNING</b> The insect screen is intended for reasonable insect control and not the retention of objects or persons within the interior. The insect screen material will not stop a person from falling through the door.	<b>⚠ WARNING</b> Metal fasteners and other hardware components may corrode when exposed to preservative treated and fire-retardant treated lumber. Obtain and use the appropriate size stainless steel fasteners and hardware as called out by the installation guide to fasten unit to any rough opening made from pressure treated and fire-retardant treated lumber. Failure to use the appropriate materials for the installation may cause a failure resulting in injury, property or product damage.
---	--	---	---	---

**RECOMMENDED TOOLS**

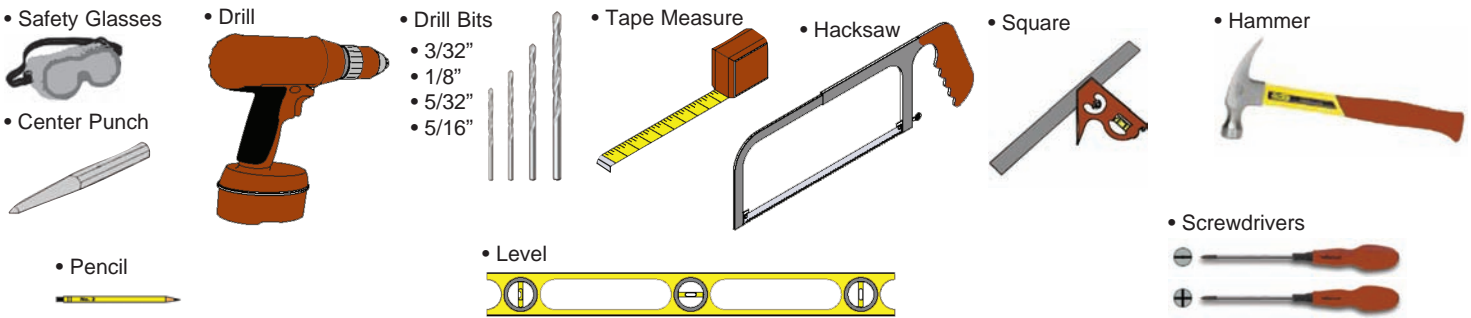

**1. VERIFY MOUNTING REQUIREMENTS**

To install the storm door, you must verify that there is the necessary opening width and height and a sufficient mounting surface.

1. Measure the width at the top, middle, and bottom of the opening (Figure 2). Measure from the inside of the brick mold or exterior trim.
2. Measure the height at the center of the opening. Measure from the inside of the brick mold or exterior trim, down to the top of the bottom sill.

Use the this table to determine if your storm door will fit into the opening:

Nominal Storm Door Sizes	Opening Sizes	
	W 1 - 3 (width)*	H (height)
36" x 80"	35 3/4" TO 36 3/8"	80" TO 80 7/8"
34" x 80"	33 3/4" TO 34 3/8"	
33" x 80"	32 3/4" TO 33 3/8"	
32" x 80"	31 3/4" TO 32 3/8"	
30" x 80"	29 3/4" TO 30 3/8"	

3. Make sure that the brick mold or exterior trim meets the mounting surface requirements to install the rain cap, hinge rail and latch rail (Figure 3). You must have a minimum of:

- 1" mounting surface depth.
- 1" mounting surface front.
- 2 1/2" space between the existing door and the mounting surface for the handle set installation.

4. Most homeowners prefer to have the storm door handle on the same side as the entry door handle. In shallow door openings, this can cause the two handles to interfere. Check for potential interference using the rough measurements (Figure 4). If you anticipate that there will be interference, hinge your storm door on opposite side of your entry door.

\* For opening widths up to 1" wider, please call our Solution Center at 1-800-933-3626 to purchase a special kit to accommodate your situation.

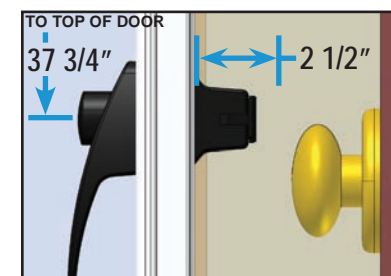
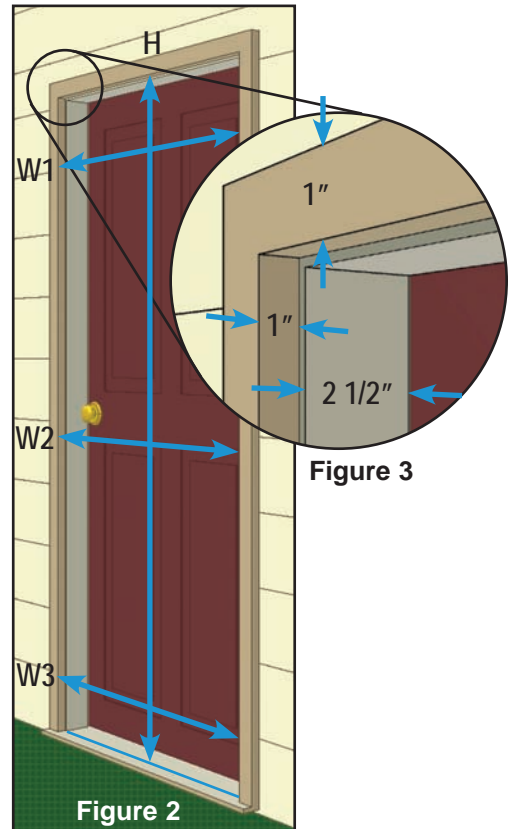

**Figure 4**

## 2. INSTALLATION PREPARATION

Tools needed:



### SELF-STORING MODEL:

In this step, you will remove the ventilating glass panel (Self-Storing model only).

1. Lay the door flat on a protected surface with the exterior side down.

TIP: Lay on door carton.

2. Remove the lower ventilating glass panel by sliding the latches at the bottom toward each other. Lift the lower portion of the ventilating glass panel up and then rotate it to remove (Figure 5).

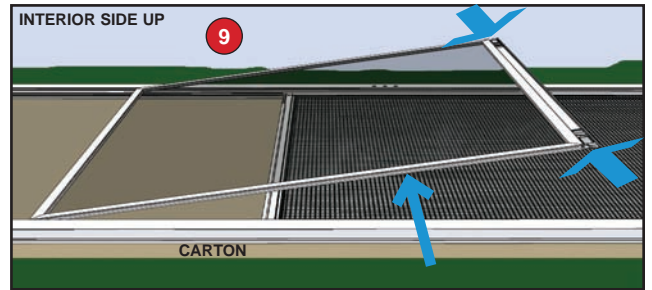

Figure 5

### CROSSBUCK & FULLVIEW MODELS:

In this step, you will remove the glass panel.

3. Lay the door flat on a protected surface with the exterior side down.

TIP: Lay on door carton.

4. Using a flathead screwdriver or putty knife and starting at one end of the retainer, push the retainer down and away from door frame (Figure 6).
5. After approximately 2" of the retainer is removed from the door frame, grasp it with your hand and pull it the rest of the way out.
6. Repeat steps 4 and 5 to remove the other retainer.
7. Remove the glass panel and stand it on its edge and out of the way to prevent damage.

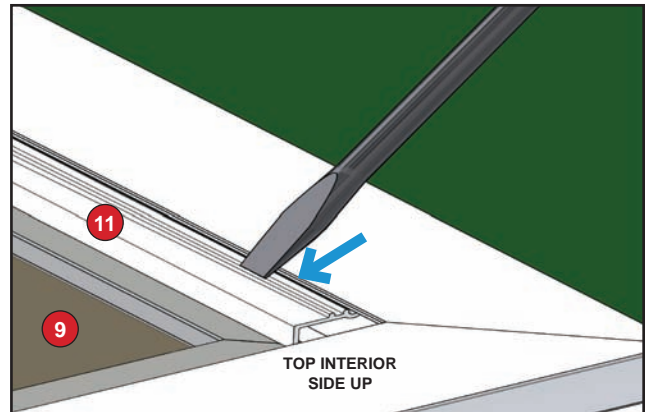

Figure 6

In this step, you will determine which side of the opening to use as the hinge side.

8. Left-hinged door (Figure 7) - Looking at the door from the exterior, a left hinged storm door will have the hinge rail on the left side of the storm door. Refer to the illustrations in the column on the left side of the installation guide under this heading:

### LEFT HINGE

9. Right-hinged door (Figure 8) - looking at the door from the exterior, a right hinged storm door will have the hinge rail on the right side of the storm door. Refer to the illustrations in the column on the right side of the installation guide under this heading:

### RIGHT HINGE

Remember, any mis-cuts during your storm door installation can be replaced free of charge. Just call our Solution Center at 1-800-933-3626.



Figure 7

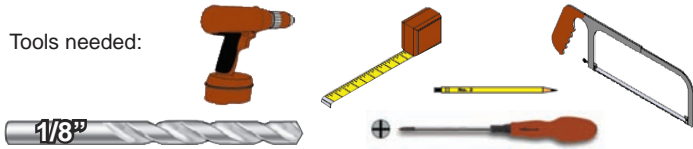

Figure 8

EXTERIOR VIEWS

### 3. PREPARE STORM DOOR FOR HANGING

Tools needed:



1 - #8x1" 

6 - #8x1" 

#### LEFT HINGE - EXTERIOR VIEW (FIGURE 9)

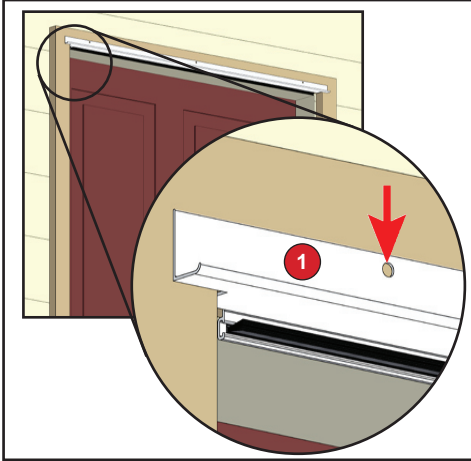

Figure 9

In this step, you will hang the rain cap against the top mounting surface (Figure 9).

1. Center the rain cap in the door opening.
2. Using a pencil, mark the hinge side hole on the mounting surface. Set rain cap aside.
3. Using the drill and 1/8" drill bit, drill a hole in the mounting surface.
4. Place the rain cap back on the door opening.
5. Screw a #8 x 1" color-matched screw in the hole as indicated by the red arrow, fastening the rain cap to the mounting surface.
6. Do not install the remaining screws at this time.

In this step, you will attach the hinge rail to the door frame.

7. Place latch side edge of door frame on the ground.

TIP: Place on door carton.

8. Locate the top of the hinge rail. (Figure 10).
9. Position the hinge rail along the hinge-side edge of the door frame, extending the top of the hinge rail 1/8" beyond the top of the door frame. Snug the top hinge against the exterior side of the door frame (Figure 11).
10. Drill a 1/8" pilot hole through the top mounting hole and into the door frame. Secure the hinge with 1 unpainted #8 x 1" screw. Repeat the process for all 5 remaining hinge leaf holes. Do not overtighten screws.

In this step, you will cut the bottom of the hinge rail to its proper length.

11. Measure the height of the door opening on the hinge side, measuring from the underside of the rain cap to the door sill. You will use this measurement to cut the hinge rail to its proper length.
12. Measure the hinge rail, starting at the top and then marking the bottom with the measurement that you took of the door opening (Figure 12).
13. Using the hacksaw, cut the hinge rail to its proper length.

#### RIGHT HINGE - EXTERIOR VIEW (FIGURE 9)

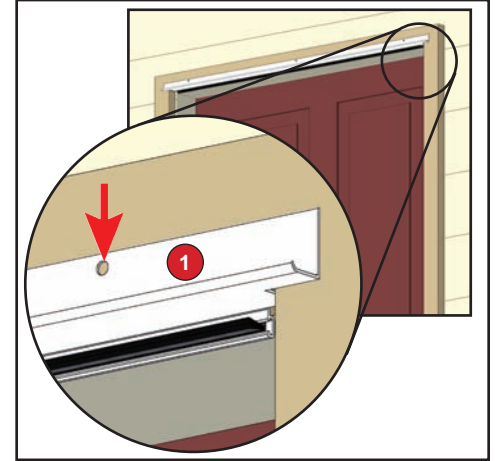

Figure 9

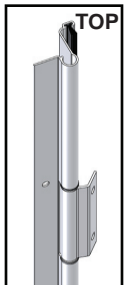

Figure 10

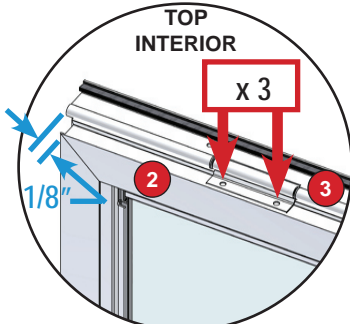

Figure 11

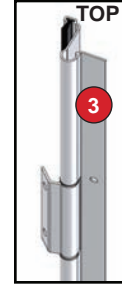

Figure 10

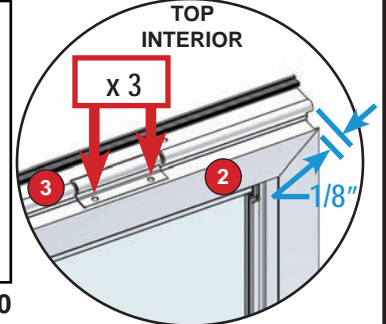

Figure 11

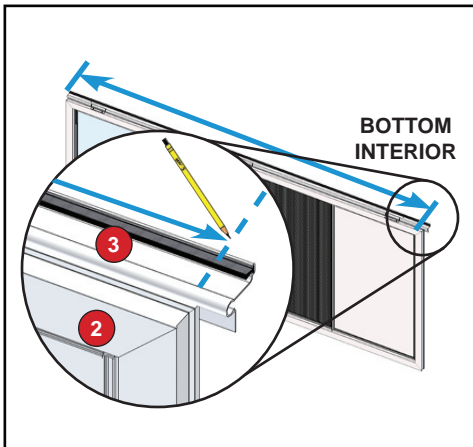

Figure 12

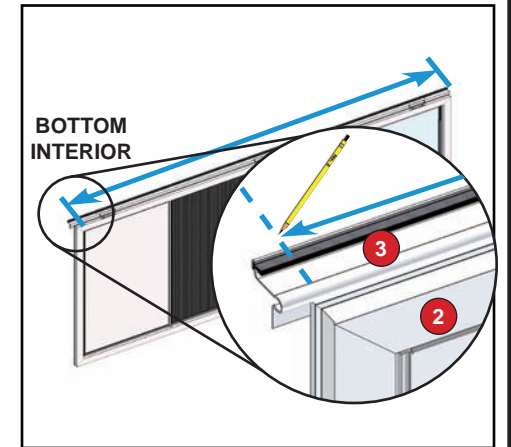
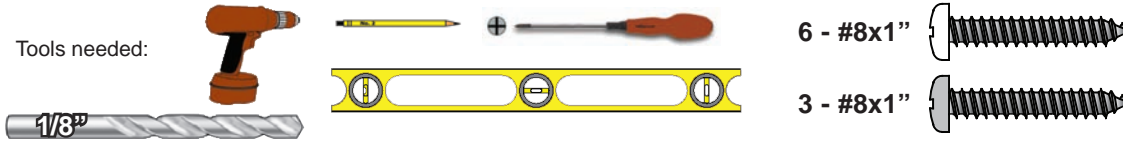

Figure 12

## 4. HANG HINGED STORM DOOR:

Tools needed:



### LEFT HINGE - EXTERIOR VIEWS

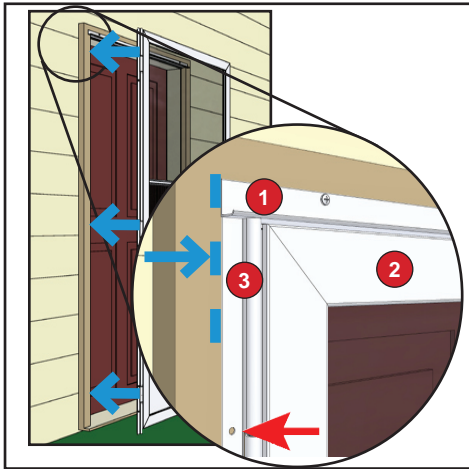

Figure 13

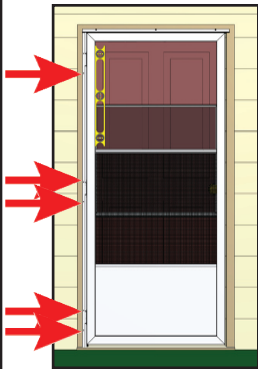

Figure 14



Figure 15

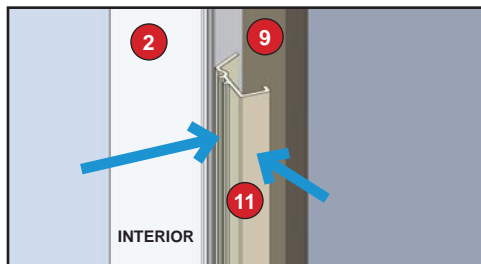

Figure 16

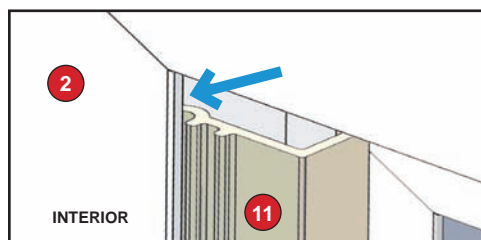

Figure 17

In this step, you will hang the storm door in the opening.

1. Position the door in the opening so that the edge of the hinge rail is flush with the end of the rain cap, and the top end of the hinge rail is butted up against the underside of the rain cap (Figure 13).
2. While holding door in position, mark onto the mounting surface the location of the top-most pre-drilled hole in the hinge rail. Once marked, remove door from opening and set aside.
3. Using the 1/8" drill bit, drill a hole in the mounting surface where you placed the mark.
4. Reposition the door in the opening and align the pre-drilled hole in the hinge rail with the hole that you drilled in the mounting surface.
5. Fasten the door to the mounting surface using one (1) #8 x 1" painted screw.
6. Using the level, make sure that the door is plumb (straight up and down).
7. While holding door in position, use the 1/8" drill bit to drill holes in the mounting surface through the pre-drilled holes in the hinge rail.
8. Fasten the hinge rail to the mounting surface using five (5) #8 x 1 painted screws (Figure 14).
9. Open the storm door.
10. Using the 1/8" drill bit, drill holes in the door jamb through the pre-drilled holes in the hinge rail.
11. Fasten the hinge rail to the door jamb using three (3) #8 x 1 painted screws (Figure 15). Do not overtighten the screws

In this step, you will re-install the glass panel.

#### SELF-STORING MODEL:

12. Now that the door is hanging, install the glass panel in the reverse order of what was done in Step 2 (Figure 5).

#### CROSSBUCK & FULLVIEW MODELS:

13. While holding the glass panel in the door frame, place the open side of the retainer against the frame of the glass panel with the angled leg towards the channel in the door side (Figure 16).
14. While pushing in on ribbed surface of retainer, slide the angled leg of the retainer into the channel in the door side. Push until it snaps into place (Figure 17). Continue this process until the entire retainer is snapped into door frame. Install the other retainer using the same technique.

### RIGHT HINGE - EXTERIOR VIEWS

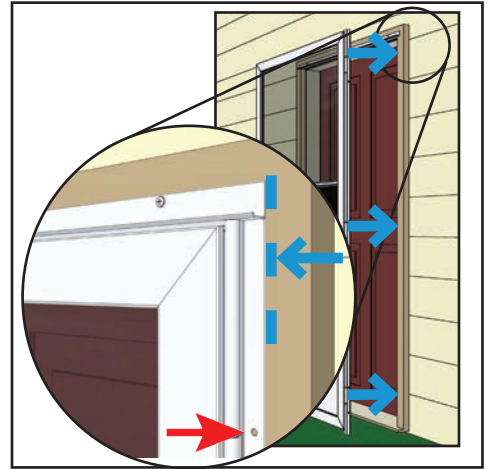

Figure 13

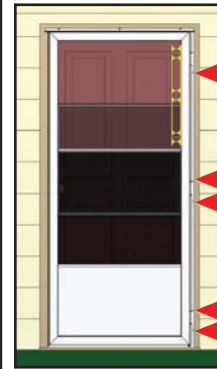

Figure 14



Figure 15

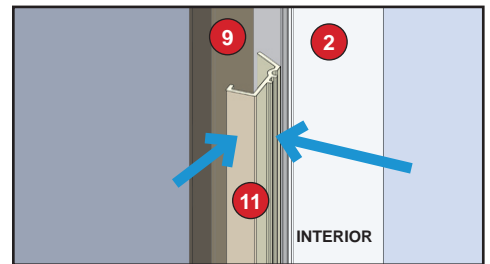

Figure 16

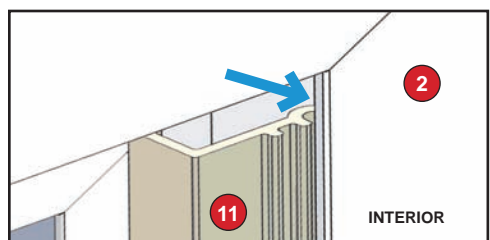
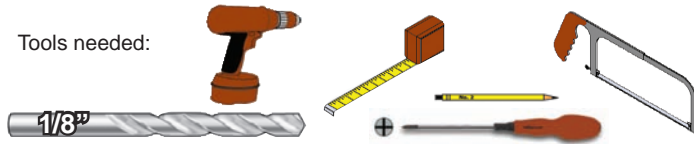

Figure 17

## 5. INSTALL REMAINING FRAME COMPONENTS:

Tools needed:



8 - #8x1"

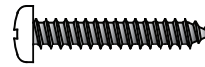

### LEFT HINGE - EXTERIOR VIEWS

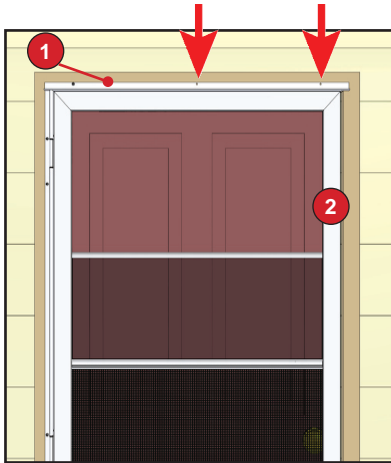

Figure 18

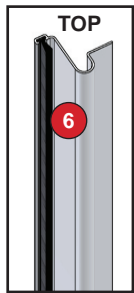

Figure 19

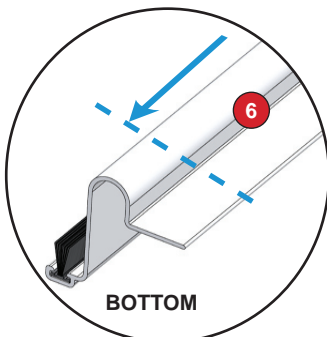

Figure 20

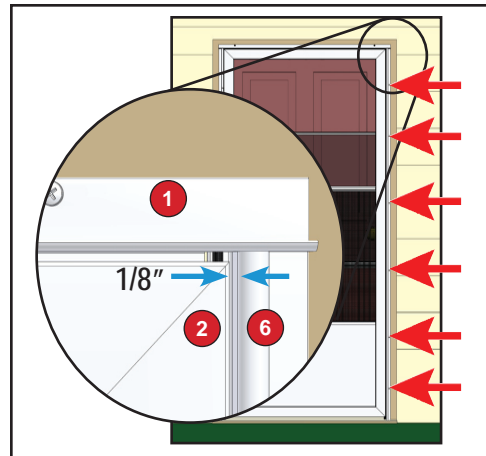

Figure 21

In this step, you will finish fastening the rain cap to the top mounting surface.

1. Close the storm door.
2. Adjust the rain cap so that the gap between the rain cap and door frame is the same along the entire length of the rain cap.
3. Using the 1/8" drill bit, drill holes in the mounting surface through the pre-drilled holes in the rain cap (Figure 18).
4. Fasten the rain cap to the mounting surface using two (2) #8 x 1" painted screws.

In this step, you will cut the bottom of the latch rail to its proper length.

5. Measure the height of the door opening, measuring from the underside of the rain cap to the door sill. You will use this measurement to cut the latch rail to its proper length.
6. Locate the top of the latch rail (Figure 19).
7. Measure the latch rail, starting at the top and then marking the bottom with the measurement that you took of the door opening.
8. Using the hacksaw, cut the latch rail to its proper length (Figure 20).

In this step, you will attach the latch rail to the mounting surface.

9. Position the latch rail so that the top end of the latch rail is butted up against the underside of the rain cap (Figure 21).
10. Close the storm door.
11. Measure the space between the latch rail and the storm door. This space should be 1/8" along the entire length.
12. Using the 1/8" drill bit, drill holes in the mounting surface through the pre-drilled holes in the latch rail. Use the pre-drilled holes in the latch rail as guides.
13. Fasten the latch rail to the door opening using six (6) #8 X 1" painted screws.

### RIGHT HINGE - EXTERIOR VIEWS

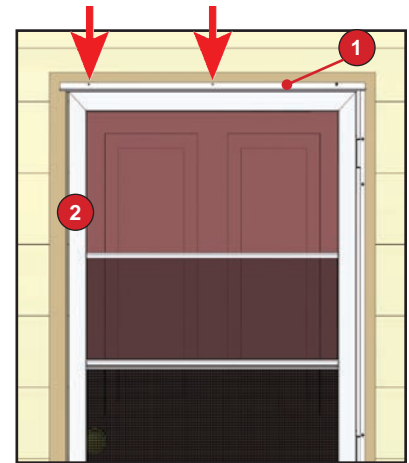

Figure 18

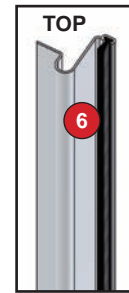

Figure 19

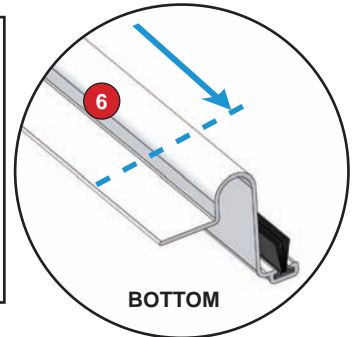

Figure 20

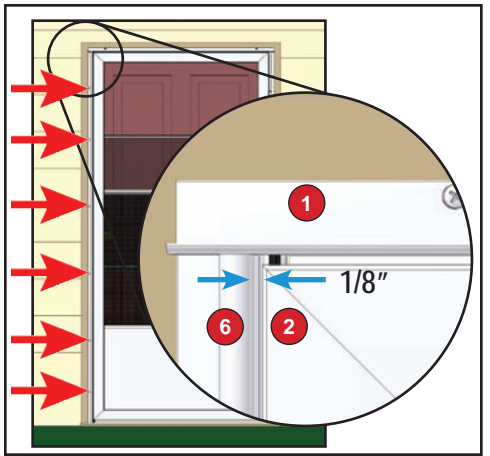

Figure 21

## 6. INSTALL SWEEP

Tools needed:



### LEFT HINGE - INTERIOR VIEWS

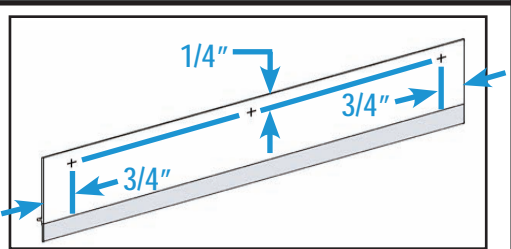

Figure 22

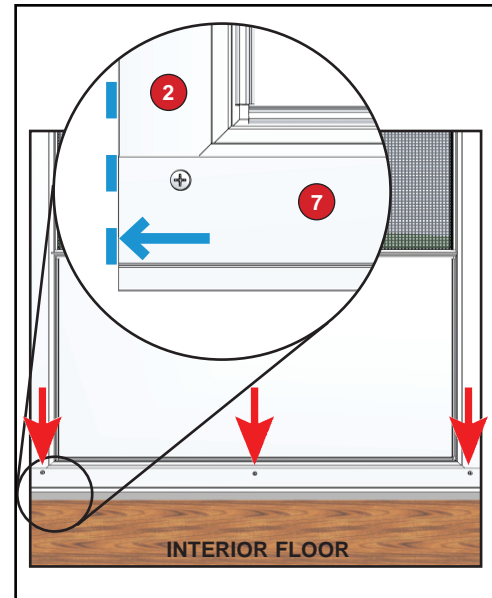

Figure 23

In this step, you will prepare the bottom sweep.

1. Measure and place a mark 3/4" in from each end of the sweep and 1/4" down from the top of the sweep. Also place a mark at the center of the sweep and down 1/4" from the top (Figure 22).
2. Drill 1/8" holes at these locations.

In this step, you will install the bottom sweep, either on the interior (shown) or exterior. Exterior installations hide gaps between the sill and bottom of the door. Interior installations are less noticeable and can provide a better seal.

3. Position the door sweep so that it is flush with the latch-side of the door frame and the flexible fin touches the sill completely (Figure 23)
4. Center punch and drill three (3) 1/8" pilot holes through the sweep mounting holes and into the door..

### CAUTION

Do not drill completely through door. This will create an unnecessary hole in the door and may cause water and air infiltration.

5. Fasten the sweep to the door using the two #8 X 1/2 color-matched (to sweep) screws.

### RIGHT HINGE - INTERIOR VIEWS

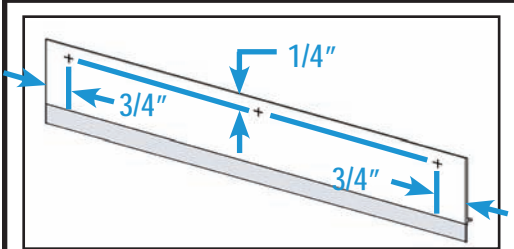

Figure 22

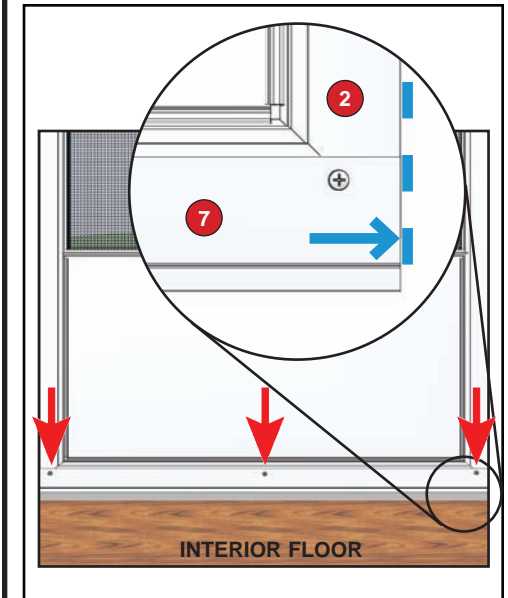

Figure 23

## 7. INSTALL CLOSER AND HANDLE SET

1. Refer to the instructions in the hardware kit box to install the closer and the handle set. Many home improvement stores or locksmiths can make duplicate keys.

## 8. ADJUST THE CLOSER

Tools needed:



In this step, you will adjust the door closer.

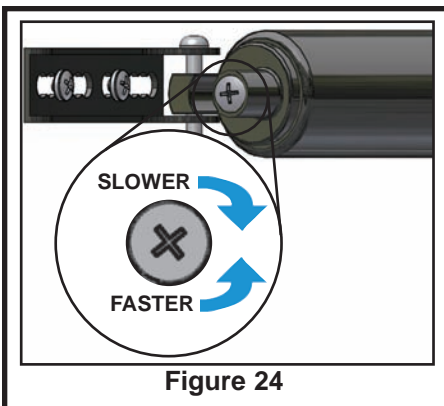

Figure 24

1. Locate the adjustment screw at the end of the closer that attaches to the door frame (Figure 24).
2. Open the door and then let it close to note the speed at which the door closes.
3. Use a Phillips head screwdriver to adjust the closer to the desired speed.
  - For a faster closing speed, turn the adjustment screw to the left (counterclockwise).
  - For a slower closing speed, turn the adjustment screw to the right (clockwise).
4. Test the speed at which the door closes after each adjustment. Adjust the screw more, if needed, to achieve the desired door closing speed.

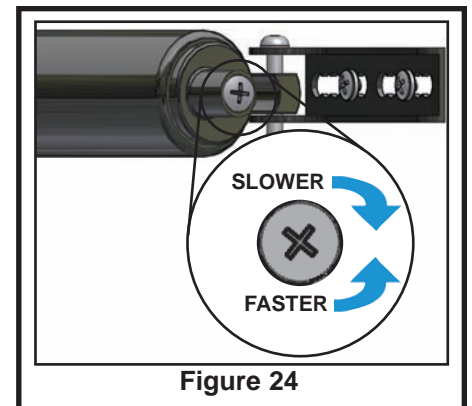

Figure 24

## REGULAR MAINTENANCE

**WINDOW GLASS** – The glass may be cleaned with any household glass cleaner. Keep glass cleaners away from painted parts and brass/nickel components.

**PLASTIC PARTS** – Plastic door components may be cleaned using a mild soap and water mixture and by gently rubbing the affected area. Do not use harsh abrasives or any product that contains chlorine.

**ALUMINUM PARTS** – Aluminum parts on the door may be cleaned using a mild soap and water mixture and by gently rubbing the affected area. Mineral spirits may be used and will not harm the paint. This will remove many items such as glue residue. Do not use harsh abrasives or any product that contains chlorine.

## LIMITED WARRANTIES

### PRODUCT LIMITED WARRANTY

**DOOR FRAME:** EMCO Enterprises, Inc. (EMCO) warrants the door frame, hinges, and painted finish on EMCO® storm door products to be free from defects in manufacturing, materials, paint adhesion, or workmanship, under normal use, for ten (10) years or as long as the original consumer purchaser owns the home in which the door was initially installed, whichever is shorter.

**COMPONENTS:** EMCO warrants the non-glass and non-insect screen fabric components of EMCO® storm doors (including brass and nickel hardware finish and the mechanical functions of locksets, closers, windows and insect screens) to be free from defects in manufacturing, materials and workmanship for a period of one (1) year from the date of original retail purchase or for as long as the original consumer purchaser owns the home in which the door was initially installed, whichever is shorter. Kick panel retention within the frame is not covered under this warranty.

In the event a door frame, hinges, insulated glass or a component fails as a result of a defect in manufacturing, materials or workmanship within the limited warranty period specified above, and upon written proof of purchase, EMCO, at its option, will provide a replacement door frame, hinge, and/or components without charge – installation is not included. Such replacement or repair is warranted for the remainder of the original limited warranty period. Please locate the door serial number and written proof of purchase and contact EMCO Consumer Support at 1-800-933-3626.

### “OOPS-PROOF” INSTALLATION LIMITED WARRANTY

EMCO Enterprises, Inc. (EMCO) warrants that any part lost or mis-cut during the original installation of your EMCO storm door will be repaired or replaced at no additional charge within ninety (90) days of the date of original purchase. This limited warranty will not apply if the part has been misused, abused or altered. Cutting parts not specified by the installation guide or mis-drilled parts are not included in this warranty.

In the event a part is lost or mis-cut within the limited warranty period, EMCO, at its option, will provide the appropriate replacement part – installation is not included. Please locate the door serial number and written proof of purchase and contact EMCO Consumer Support at 1-800-933-3626.

### GENERAL LIMITED WARRANTY INFORMATION

The limited warranties set forth in this document are the only express warranties (whether written or oral) applicable to EMCO® storm doors, and no one is authorized to modify or expand these limited warranties. All warranty claims must be made during the applicable warranty periods.

**ALL IMPLIED WARRANTIES INCLUDING MERCHANTABILITY AND FITNESS FOR A PARTICULAR PURPOSE ARE LIMITED TO THE APPLICABLE STATUTE OF LIMITATION, BUT IN NO CASE WILL THEY EXTEND BEYOND THE TERM OF THE LIMITED WARRANTIES SET FORTH ABOVE. EMCO EXCLUDES AND WILL NOT PAY FOR INCIDENTAL OR CONSEQUENTIAL DAMAGES, WHETHER ARISING OUT OF CONTRACT, TORT OR OTHERWISE, AND ITS LIABILITY WILL IN ALL INSTANCES BE LIMITED TO THE REPAIR OR REPLACEMENT OF THE DEFECTIVE PRODUCT.**

Some states do not allow the exclusion of incidental and consequential damages, or limitation of the duration of an implied warranty, so the above limitations or exclusions may not apply to you.

This limited warranty gives you specific legal rights, and you may also have other rights that may vary from state to state and in Canada.

**What is NOT covered by this limited warranty:** Damage caused by 1) improper installation, maintenance, or use; 2) chemicals or airborne pollutants, such as salt or acid rain; 3) acts of God, including wind damage; 4) Products not manufactured by EMCO

EMCO Enterprises, Inc. is a wholly owned subsidiary of Andersen Corporation. EMCO manufactures Andersen® and EMCO® storm doors. EMCO supports the limited warranties covering Andersen® Storm and Screen Doors. “Andersen”, “EMCO” and all other marks where denoted are trademarks of Andersen Corporation. ©2011 Andersen Corporation. All rights reserved.

Reprinted and effective as of May, 2011.