



Count on it.

Operator's Manual

TimeCutter® HD ZX4800 and ZX5400 Riding Mower

Model No. 75201—Serial No. 401500000 and Up

Model No. 75202—Serial No. 401500000 and Up

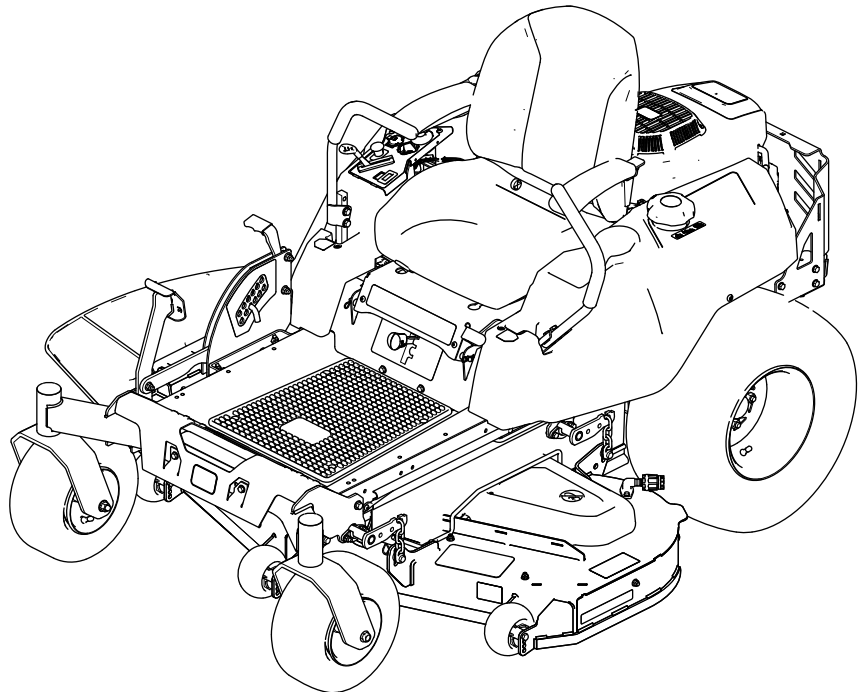

⚠ WARNING

CALIFORNIA Proposition 65 Warning

This product contains a chemical or chemicals known to the State of California to cause cancer, birth defects, or reproductive harm.

The engine exhaust from this product contains chemicals known to the State of California to cause cancer, birth defects, or other reproductive harm.

It is a violation of California Public Resource Code Section 4442 or 4443 to use or operate the engine on any forest-covered, brush-covered, or grass-covered land unless the engine is equipped with a spark arrester, as defined in Section 4442, maintained in effective working order or the engine is constructed, equipped, and maintained for the prevention of fire.

Gross or Net Torque

The gross or net torque of this engine was laboratory rated by the engine manufacturer in accordance with the Society of Automotive Engineers (SAE) J1940 or J2723. As configured to meet safety, emission, and operating requirements, the actual engine torque on this class of mower will be significantly lower.

Go to www.Toro.com to view specifications on your mower model.

⚠ WARNING

Removing standard original equipment parts and accessories may alter the warranty, traction, and safety of the machine. Failure to use original Toro parts could cause serious injury or death. Making unauthorized changes to the engine, fuel or venting system, may violate EPA and CARB regulations.

Replace all parts including, but not limited to, tires, belts, blades, and fuel system components with original Toro parts.

***Important:* If you are using a machine with a Toro engine above 1500 m (5,000 ft) for a continuous period, ensure that the High Altitude Kit has been installed so that the engine meets CARB/EPA emission regulations. The High Altitude Kit increases engine performance while preventing spark-plug fouling, hard starting, and increased emissions. Once you have installed the kit, attach the high-altitude label next to the serial decal on the machine. Contact any Authorized Toro Service Dealer to obtain the proper High Altitude Kit and**

high-altitude label for your machine. To locate a dealer convenient to you, access our website at www.Toro.com or contact our Toro Customer Care Department at the number(s) listed in your Emission Control Warranty Statement.

Remove the kit from the engine and restore the engine to its original factory configuration when running the engine under 1500 m (5,000 ft). Do not operate an engine that has been converted for high-altitude use at lower altitudes; otherwise, you could overheat and damage the engine.

If you are unsure whether or not your machine has been converted for high-altitude use, look for the following label.

NOTE: THE ENGINE ON THIS PRODUCT HAS BEEN MODIFIED FOR USE AT ABOVE 5,000 FEET ELEVATION. IF USING BELOW 5,000 FEET, IT MUST BE REVISED BACK TO ORIGINAL SPECIFICATIONS.

127-9363

decal127-9363

Introduction

This rotary-blade, riding lawn mower is intended to be used by homeowners in residential applications. It is designed primarily for cutting grass on well-maintained lawns. It is not designed for cutting brush, mowing grass and other growth alongside highways, or for agricultural uses.

Read this information carefully to learn how to operate and maintain your product properly and to avoid injury and product damage. You are responsible for operating the product properly and safely.

You may contact Toro directly at www.Toro.com for product safety and operation training materials, accessory information, help finding a dealer, or to register your product.

Whenever you need service, genuine Toro parts, or additional information, contact an Authorized Service Dealer or Toro Customer Service and have the model and serial numbers of your product ready. [Figure 1](#) identifies the location of the model and serial numbers on the product. Write the numbers in the space provided.

***Important:* With your mobile device, you can scan the QR code on the serial number decal (if equipped) to access warranty, parts, and other product information.**

Contents

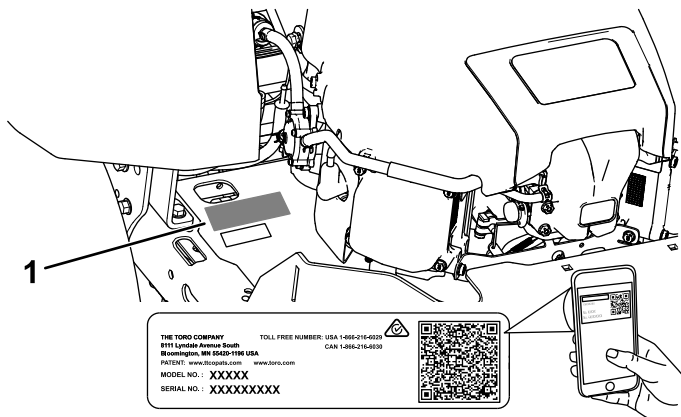

Figure 1

1. Model and serial number plate

Write the product model and serial numbers in the space below:

Model No. _____
Serial No. _____

This manual identifies potential hazards and has safety messages identified by the safety-alert symbol (Figure 2), which signals a hazard that may cause serious injury or death if you do not follow the recommended precautions.



Figure 2
Safety-Alert Symbol

This manual uses 2 words to highlight information. **Important** calls attention to special mechanical information and **Note** emphasizes general information worthy of special attention.

Safety	4
General Safety	4
Slope Indicator	5
Safety and Instructional Decals	6
Product Overview	10
Controls	10
Before Operation	12
Before Operation Safety	12
Adding Fuel	12
Performing Daily Maintenance	13
Breaking in a New Machine	13
Using the Safety-Interlock System	14
Positioning the Seat	14
Adjusting the Motion-Control Levers	15
During Operation	15
During Operation Safety	15
Operating the Parking Brake	17
Operating the Mower Blade-Control Switch (PTO)	18
Operating the Throttle	18
Operating the Choke	18
Starting the Engine	19
Shutting Off the Engine	19
Using the Motion-Control Levers	19
Driving the Machine	20
Using the Smart Speed™ Control System	21
Using the Side Discharge	21
Adjusting the Height of Cut	22
Adjusting the Anti-Scalp Rollers	22
Using Attachments and Accessories	23
Operating Tips	23
After Operation	24
After Operation Safety	24
Pushing the Machine by Hand	24
Transporting the Machine	25
Maintenance	27
Recommended Maintenance Schedule(s)	27
Pre-Maintenance Procedures	28
Maintenance Safety	28
Engine Maintenance	28
Engine Safety	28
Servicing the Air Cleaner	28
Servicing the Engine Oil	30
Servicing the Spark Plug	32
Cleaning the Cooling System	33
Fuel System Maintenance	34
Replacing the In-Line Fuel Filter	34
Electrical System Maintenance	35
Electrical System Safety	35
Servicing the Battery	35
Servicing the Fuses	36
Drive System Maintenance	37
Checking the Tire Pressure	37
Mower Maintenance	37
Servicing the Cutting Blades	37

Leveling the Mower Deck.....	40
Removing the Mower Deck.....	42
Installing the Mower Deck.....	43
Replacing the Grass Deflector.....	43
Mower Belt Maintenance.....	44
Inspecting the Belts.....	44
Replacing the Mower Belt.....	44
Cleaning.....	45
Washing the Underside of the Mower.....	45
Disposing of Waste.....	46
Storage.....	46
Storage Safety.....	46
Cleaning and Storage.....	46
Storing the Battery.....	47
Troubleshooting.....	48
Schematics.....	50

Safety

This machine has been designed in accordance with ANSI B71.1-2012.

General Safety

This product is capable of amputating hands and feet and of throwing objects. Always follow all safety instructions to avoid serious personal injury.

Using this product for purposes other than its intended use could prove dangerous to you and bystanders.

- Do not operate the machine near drop-offs, ditches, embankments, water, or other hazards, or on slopes greater than 15 degrees.
- Read and understand the contents of this *Operator's Manual* before starting the engine.
- Do not put your hands or feet near moving components of the machine.
- Do not operate the machine without all guards and other safety protective devices in place and working on the machine.
- Keep children and bystanders out of the operating area. Never allow children to operate the machine.
- Stop the machine and shut off the engine before servicing, fueling, or unclogging the machine.

Improperly using or maintaining this machine can result in injury. To reduce the potential for injury, comply with these safety instructions and always pay attention to the safety-alert symbol, which means Caution, Warning, or Danger—personal safety instruction. Failure to comply with these instructions may result in personal injury or death.

You can find additional safety information where needed throughout this manual.

Slope Indicator

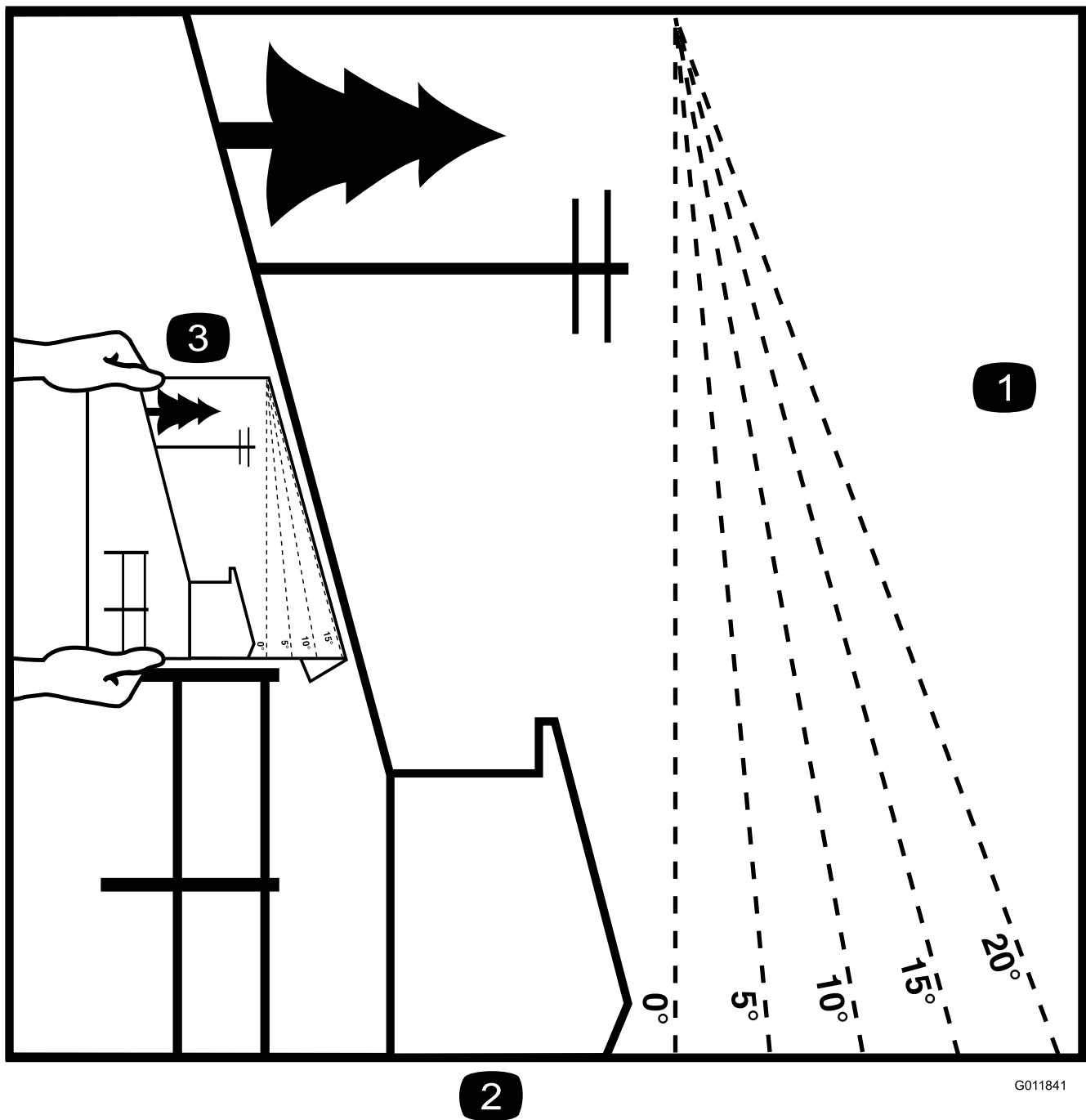

G011841

g011841

2

Figure 4

This page may be copied for personal use.

1. The maximum slope you can operate the machine on is **15 degrees**. Use the slope chart to determine the degree of slope of hills before operating. **Do not operate this machine on a slope greater than 15 degrees**. Fold along the appropriate line to match the recommended slope.
2. Align this edge with a vertical surface, a tree, building, fence pole, etc.
3. Example of how to compare slope with folded edge

Safety and Instructional Decals



Safety decals and instructions are easily visible to the operator and are located near any area of potential danger. Replace any decal that is damaged or missing.

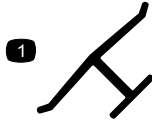

decaloemmark

Manufacturer's Mark

1. Indicates the blade is identified as a part from the original machine manufacturer.

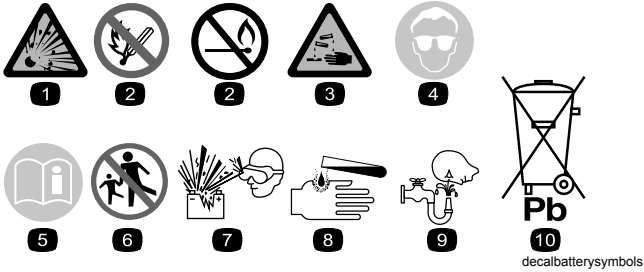

Battery Symbols

Some or all of these symbols are on your battery.

- | | |
|--|---|
| 1. Explosion hazard | 6. Keep bystanders a safe distance away from the battery. |
| 2. No fire, open flame, or smoking | 7. Wear eye protection; explosive gases can cause blindness and other injuries. |
| 3. Caustic liquid/chemical burn hazard | 8. Battery acid can cause blindness or severe burns. |
| 4. Wear eye protection. | 9. Flush eyes immediately with water and get medical help fast. |
| 5. Read the <i>Operator's Manual</i> . | 10. Contains lead; do not discard |

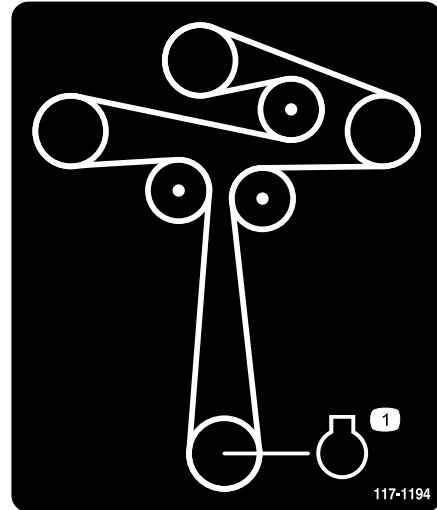

117-1194

decal117-1194

117-1194

1. Engine

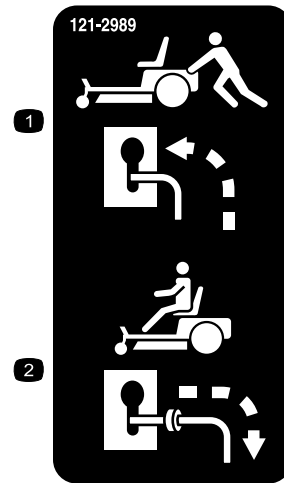

decal121-2989b

121-2989

1. Bypass lever position for pushing the machine
2. Bypass lever position for operating the machine

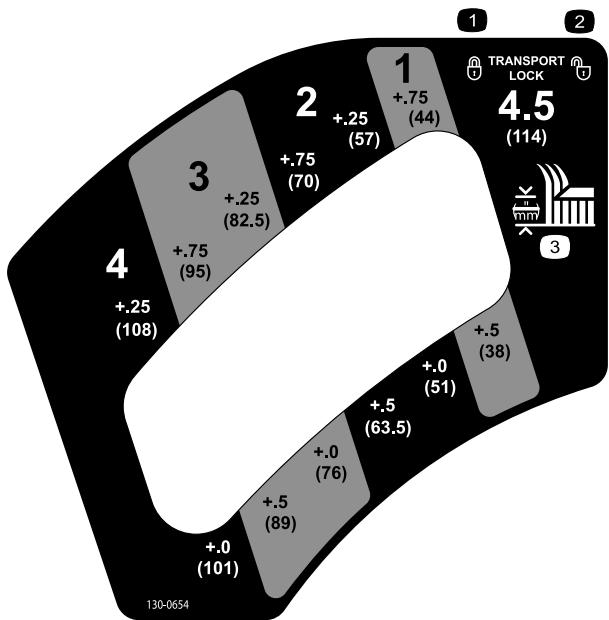

130-0654

decal130-0654

1. Transport—lock
2. Transport—unlock
3. Height of cut



130-0731

decal130-0731

1. Warning—thrown object hazard; keep the deflector shield in place.
2. Cutting hazard of hand or foot, mower blade—keep away from moving parts.

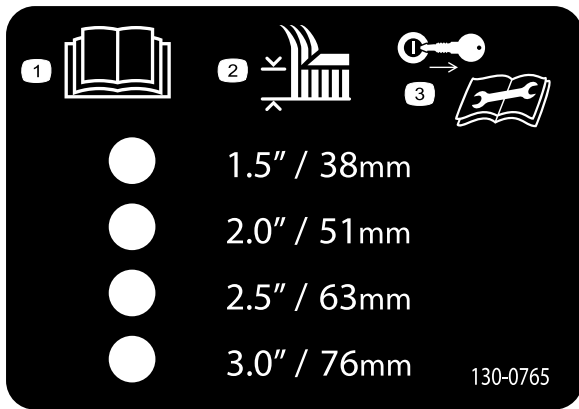

130-0765

decal130-0765

1. Read the *Operator's Manual*.
2. Height-of-cut selection
3. Remove the key from the key switch and read the *Operator's Manual* before performing maintenance.

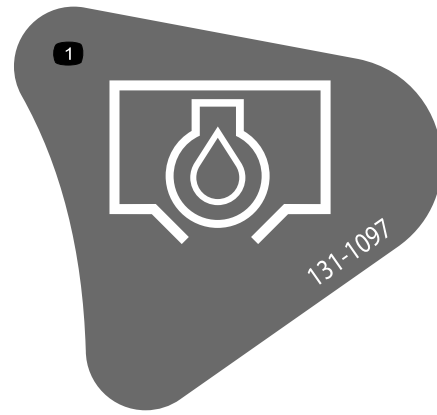

131-1097

decal131-1097

1. Oil drain

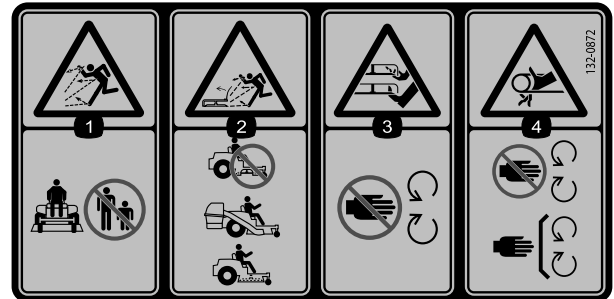

132-0872

decal132-0872

1. Thrown object hazard—keep bystanders away from the machine.
2. Thrown object hazard, raised baffle—do not operate the machine with an open deck; use a bagger or a baffle.
3. Severing hazard of hand or foot—keep away from moving parts.
4. Entanglement hazard—keep away from moving parts; keep all guards and shields in place.

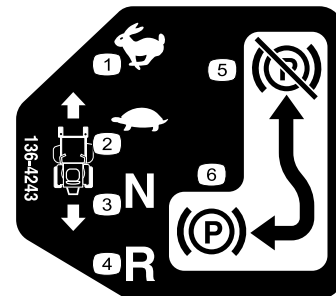

136-4243

decal136-4243

1. Fast
2. Slow
3. Neutral
4. Reverse
5. Parking brake disengaged
6. Parking brake engaged

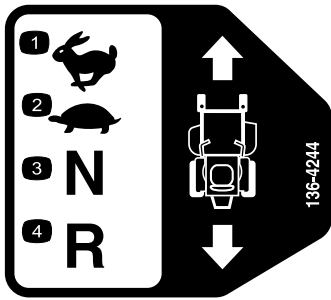

136-4244

decal136-4244

- 1. Fast
- 2. Slow
- 3. Neutral
- 4. Reverse

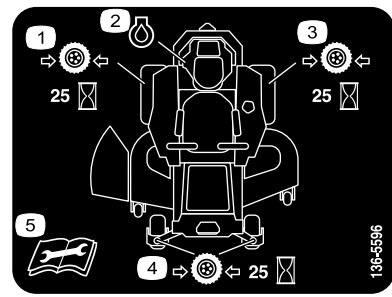

136-5596

decal136-5596

- 1. Check the tire pressure every 25 operating hours.
- 2. Engine oil
- 3. Check the tire pressure every 25 operating hours.
- 4. Check the tire pressure every 25 operating hours.
- 5. Read the *Operator's Manual* before performing maintenance.



136-9186

decal136-9186

- 1. Read the *Operator's Manual* before adding weight to the bucket.

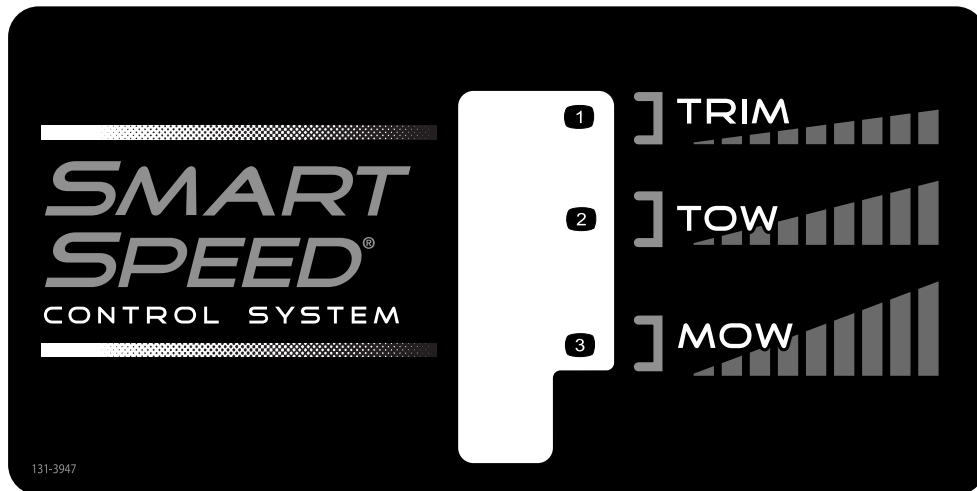

131-3947

decal131-3947

- 1. Trim—slow
- 2. Tow—medium
- 3. Mow—fast

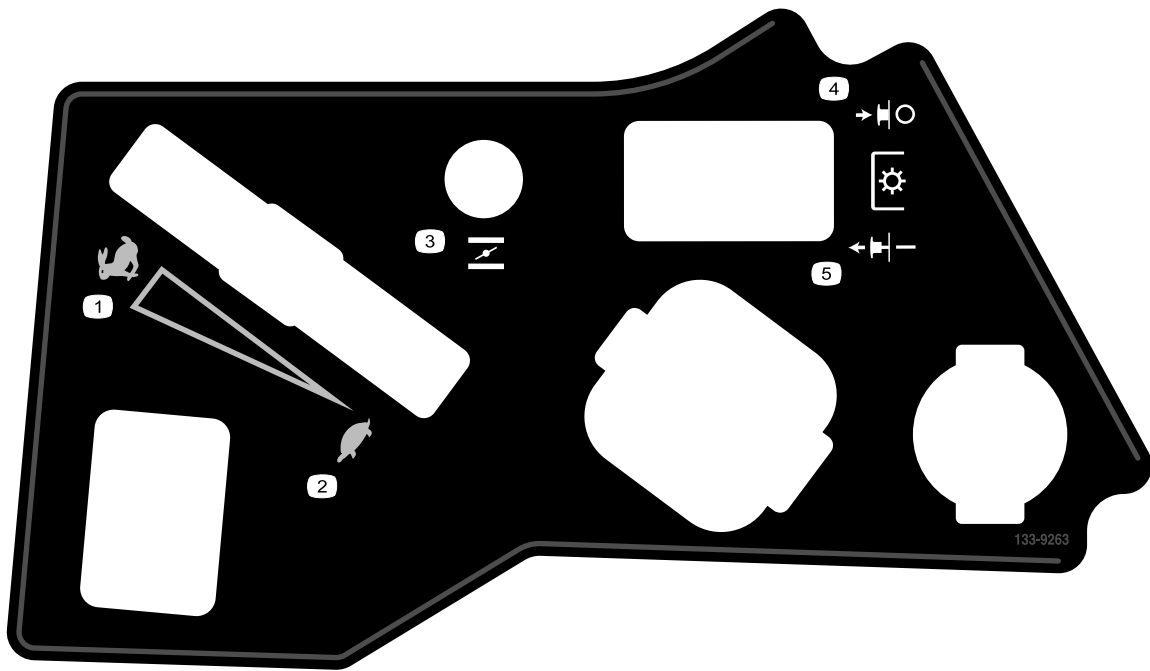

133-9263

decal133-9263

- | | |
|----------|------------------|
| 1. Fast | 4. PTO disengage |
| 2. Slow | 5. PTO engage |
| 3. Choke | |

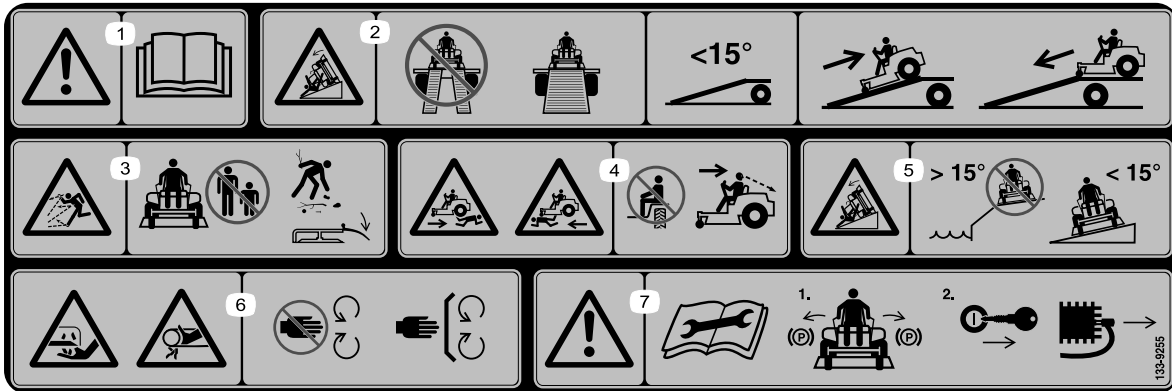

133-9255

decal133-9255

Note: This machine complies with the industry standard stability test in the static lateral and longitudinal tests with the maximum recommended slope indicated on the decal. Review the instructions for operating the machine on slopes in the *Operator's Manual* as well as the conditions in which you would operate the machine to determine whether you can operate the machine in those conditions on that day and at that site. Changes in the terrain can result in a change in slope operation for the machine. If possible, keep the cutting units lowered to the ground while operating the machine on slopes. Raising the cutting units while operating on slopes can cause the machine to become unstable.

- | | |
|---|--|
| 1. Warning—read the <i>Operator's Manual</i> . | 5. Tipping hazard—do not use on slopes near open water; do not use on slopes greater than 15°. |
| 2. Ramp hazard—do not use dual ramps when loading onto a trailer; use 1 ramp wide enough for the machine; use a ramp with a slope less than 15°; back up the ramp when loading the machine and drive forward off the ramp when unloading. | 6. Cutting and pinch hazard—keep away from moving parts; keep all guards and shields in place. |
| 3. Thrown object hazard—keep bystanders a safe distance from the machine, pick up debris before operating, and keep the deflector shield down. | 7. Warning—before performing maintenance, read the <i>Operator's Manual</i> ; engage the parking brake, remove the key, and disconnect the spark plug. |
| 4. Bodily harm hazard—do not carry passengers; look behind you when mowing in reverse. | |

Product Overview

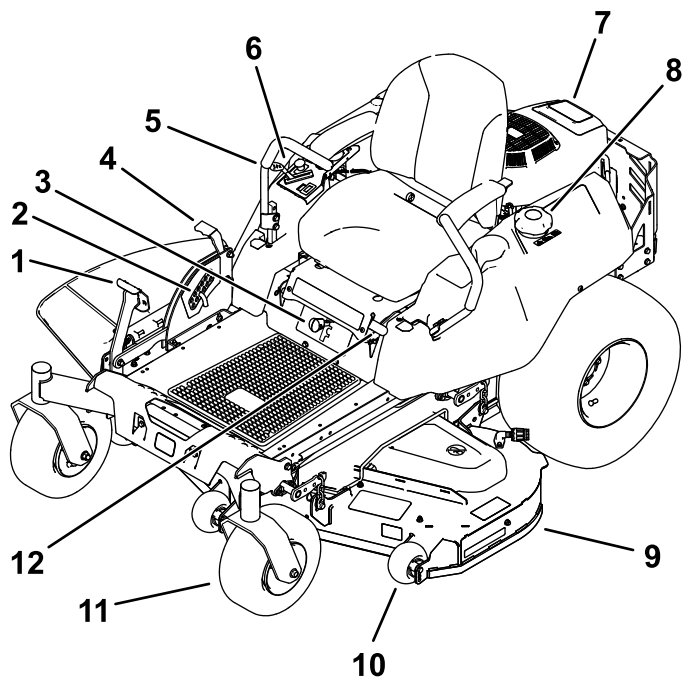

Figure 5

g188739

- | | |
|---------------------------------------|-------------------------|
| 1. Deck-lift pedal | 7. Engine |
| 2. Height-of-cut pin | 8. Fuel cap |
| 3. Height-of-cut lever/transport lock | 9. Mower deck |
| 4. Smart Speed™ lever | 10. Anti-scalp roller |
| 5. Motion-control lever | 11. Caster wheel |
| 6. Controls | 12. Parking-brake lever |

Controls

Become familiar with all controls in [Figure 6](#) and [Figure 7](#) before you start the engine and operate the machine.

Control Panel

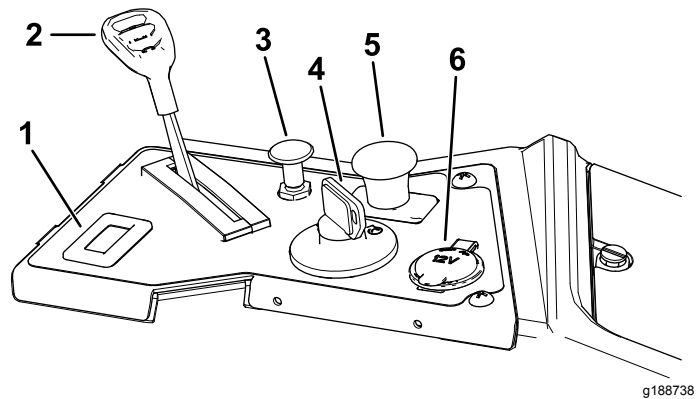

g188738

Figure 6

- | | |
|---------------------|---|
| 1. Hour meter | 4. Key switch |
| 2. Throttle control | 5. Blade-control switch (power takeoff) |
| 3. Choke control | 6. 12 V power point |

Fuel Gauge

The fuel gauge displays the amount of fuel in the tank ([Figure 7](#)).

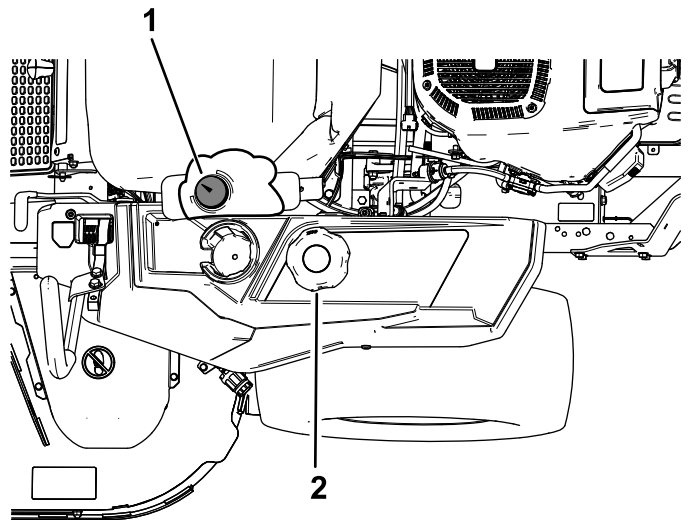

g238298

Figure 7

- | | |
|---------------|------------------|
| 1. Fuel gauge | 2. Fuel-tank cap |
|---------------|------------------|

Throttle Control

The throttle controls the engine speed, and it has a continuous-variable setting from the SLOW to FAST position ([Figure 6](#)).

Choke Control

Use the choke control to start a cold engine.

Hour Meter

The hour meter records the number of hours the engine has operated. It operates when the engine is running. Use these times for scheduling regular maintenance (Figure 6).

Motion-Control Levers

Use the motion-control levers to drive the machine forward, reverse, and turn either direction (Figure 5).

Neutral-Lock Position

Move the motion-control levers outward from the center to the NEUTRAL-LOCK position when exiting the machine (Figure 21). Always position the motion-control levers into the NEUTRAL-LOCK position when you stop the machine or leave it unattended.

Parking-Brake Lever

The parking-brake lever is located on the left side of the console (Figure 5). The brake lever engages a parking brake on the drive wheels.

To engage the parking brake, pull up the lever until it latches into the detent slot.

To disengage the parking brake, pull the lever out of the detent slot and toward you, then push it down.

Foot Pedal Deck-Lift System

The foot pedal deck-lift system allows you to lower and raise the deck from the seated position. You can use the foot pedal to lift the deck briefly to avoid obstacles or lock the deck in the highest height of cut or transport position (Figure 5).

Smart Speed™ Control System Lever

The Smart Speed™ Control-System lever, located below the operating position, gives you a choice to drive the machine at 3 speed ranges— trim, tow, and mow (Figure 24).

12 V Power Point

Use the power point to power 12 V accessories (Figure 6).

Important: When not using the 12 V power point, insert the rubber plug to prevent damage to the power point.

Key Switch

The key switch, used to start and shut off the engine, has 3 positions: OFF, RUN, and START. Refer to [Starting the Engine \(page 19\)](#).

Blade-Control Switch (Power Takeoff)

The blade-control switch, represented by a power-takeoff (PTO) symbol, engages and disengages power to the mower blades (Figure 6).

Height-of-Cut Lever

The height-of-cut lever works with the foot pedal to lock the deck in a specific cutting height. Adjust the height of cut only when the machine is not moving (Figure 5).

Attachments/Accessories

A selection of Toro approved attachments and accessories is available for use with the machine to enhance and expand its capabilities. Contact your Authorized Service Dealer or Distributor or go to www.Toro.com for a list of all approved attachments and accessories.

To best protect your investment and maintain optimal performance of your Toro equipment, count on Toro genuine parts. When it comes to reliability, Toro delivers replacement parts designed to the exact engineering specification of our equipment. For peace of mind, insist on Toro genuine parts.

Operation

Note: Determine the left and right sides of the machine from the normal operating position.

Before Operation

Before Operation Safety

General Safety

- Never allow children or untrained people to operate or service the machine. Local regulations may restrict the age of the operator. The owner is responsible for training all operators and mechanics.
- Become familiar with the safe operation of the equipment, operator controls, and safety signs.
- Know how to stop the machine and shut off the engine quickly.
- Check that operator-presence controls, safety switches, and shields are attached and functioning properly. Do not operate the machine unless they are functioning properly.
- Before mowing, always inspect the machine to ensure that the blades, blade bolts, and cutting assemblies are in good working condition. Replace worn or damaged blades and bolts in sets to preserve balance.
- Inspect the area where you will use the machine and remove all objects that the machine could throw.
- Evaluate the terrain to determine the appropriate equipment and any attachments or accessories required to operate the machine properly and safely.

Fuel Safety

- To avoid personal injury or property damage, use extreme care in handling fuel. Fuel vapors are flammable and explosive.
- Extinguish all cigarettes, cigars, pipes, and other sources of ignition.
- Use only an approved fuel container.
- Do not remove the fuel cap or add fuel to the fuel tank while the engine is running or while hot.
- Do not refuel the machine indoors.
- Do not store the machine or fuel container where there is an open flame, spark, or pilot light, such as on a water heater or on other appliances.
- Do not fill containers inside a vehicle or on a truck or trailer bed with a plastic liner. Always place

containers on the ground, away from your vehicle before filling.

- Remove the equipment from the truck or trailer and refuel it while it is on the ground. If this is not possible, then refuel from a portable container rather than a fuel-dispenser nozzle.
- Do not operate the machine without the entire exhaust system in place and in proper working condition.
- Keep the fuel-dispenser nozzle in contact with the rim of the fuel tank or container opening at all times until fueling is complete. Do not use a nozzle lock-open device.
- If you spill fuel on your clothing, change your clothing immediately. Wipe up any fuel that spills.
- Never overfill the fuel tank. Replace the fuel cap and tighten it securely.
- Store fuel in an approved container and keep it out of the reach of children. Never buy more than a 30-day supply of fuel.
- Do not fill the fuel tank completely full. Add fuel to the fuel tank until the level is 6 to 13 mm (1/4 to 1/2 inch) below the bottom of the filler neck. This empty space in the tank allows fuel to expand.
 - Avoid prolonged breathing of vapors.
 - Keep your face away from the nozzle and fuel tank opening.
 - Avoid contact with skin; wash off spills with soap and water.

Adding Fuel

Recommended Fuel

- For best results, use only clean, fresh (less than 30 days old), unleaded gasoline with an octane rating of 87 or higher ((R+M)/2 rating method).
- **Ethanol:** Gasoline with up to 10% ethanol (gasohol) or 15% MTBE (methyl tertiary butyl ether) by volume is acceptable. Ethanol and MTBE are not the same. Gasoline with 15% ethanol (E15) by volume is not approved for use. **Never use gasoline that contains more than 10% ethanol by volume**, such as E15 (contains 15% ethanol), E20 (contains 20% ethanol), or E85 (contains up to 85% ethanol). Using unapproved gasoline may cause performance problems and/or engine damage which may not be covered under warranty.
- **Do not** use gasoline containing methanol.
- **Do not** store fuel either in the fuel tank or fuel containers over the winter unless you use a fuel stabilizer.
- **Do not** add oil to gasoline.

Using Stabilizer/Conditioner

Use a fuel stabilizer/conditioner in the machine to provide the following benefits:

- Keeps fuel fresh during storage of 90 days or less (drain the fuel tank when storing the machine for more than 90 days)
- Cleans the engine while it runs
- Eliminates gum-like varnish buildup in the fuel system, which causes hard starting

Important: Do not use fuel additives containing methanol or ethanol.

Add the correct amount of fuel stabilizer/conditioner to the fuel.

Note: A fuel stabilizer/conditioner is most effective when mixed with fresh fuel. To minimize the chance of varnish deposits in the fuel system, use fuel stabilizer at all times.

Filling the Fuel Tank

1. Park the machine on a level surface.
2. Engage the parking brake.
3. Shut off the engine and remove the key.
4. Clean around the fuel-tank cap.
5. Fill the fuel tank until the fuel gauge reads at the full mark ([Figure 8](#)).

Note: Do not fill the fuel tank completely full. The empty space in the tank allows the fuel to expand.

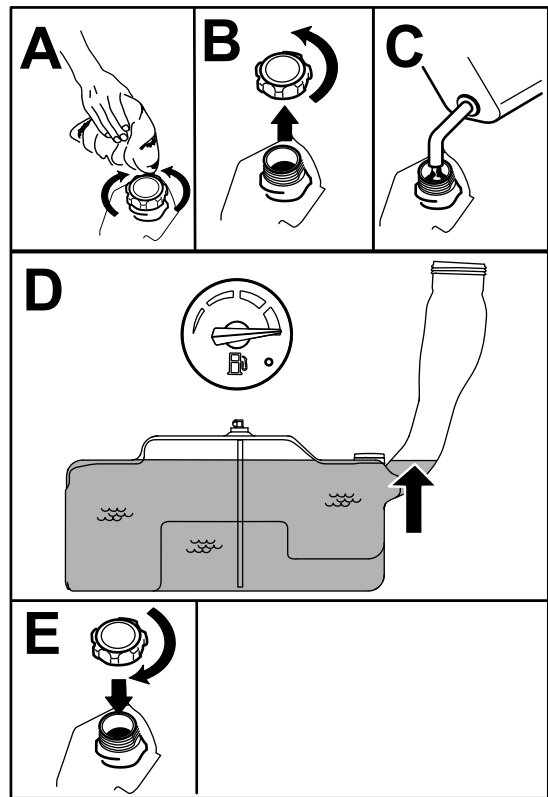

Figure 8

g197123

Performing Daily Maintenance

Before starting the machine each day, perform the Each Use/Daily procedures listed in [Maintenance \(page 27\)](#).

Breaking in a New Machine

New engines take time to develop full power. Mower decks and drive systems have higher friction when new, placing additional load on the engine. Allow 40 to 50 hours of break-in time for new machines to develop full power and best performance.

Using the Safety-Interlock System

⚠ WARNING

If the safety-interlock switches are disconnected or damaged, the machine could operate unexpectedly, causing personal injury.

- Do not tamper with the interlock switches.
- Check the operation of the interlock switches daily and replace any damaged switches before operating the machine.

Understanding the Safety-Interlock System

The safety-interlock system is designed to prevent the engine from starting unless:

- The blade-control switch (PTO) is disengaged.
- The motion-control levers are in the NEUTRAL-LOCK position.
- The parking brake is engaged.

The safety-interlock system also is designed to shut off the engine whenever the control levers are out of the NEUTRAL-LOCK position and you rise from the seat.

Testing the Safety-Interlock System

Service Interval: Before each use or daily

Test the safety-interlock system before you use the machine each time. If the safety system does not operate as described below, have an Authorized Service Dealer repair the safety system immediately.

1. Sit on the seat, engage the parking brake, and move the blade-control switch (PTO) to the ON position. Try starting the engine; the engine should not crank.
2. Sit on the seat, engage the parking brake, and move the blade-control switch (PTO) to the OFF position. Move either motion-control lever (out of the NEUTRAL-LOCK position). Try starting the engine; the engine should not crank. Repeat for other control lever.
3. Sit on the seat, engage the parking brake, move the blade-control switch (PTO) to the OFF position, and move the motion-control levers to the NEUTRAL-LOCK position. Start the engine. While the engine is running, release the parking brake, engage the blade-control switch (PTO),

and rise slightly from the seat; the engine should shut off.

4. Sit on the seat, engage the parking brake, move the blade-control switch (PTO) to the OFF position, and move the motion-control levers to NEUTRAL-LOCK position. Start the engine. While the engine is running, center either motion-control lever and move it forward or reverse; the engine should shut off. Repeat for other motion-control lever.
5. Sit on the seat, disengage the parking brake, move the blade-control switch (PTO) to the OFF position, and move the motion-control levers to NEUTRAL-LOCK position. Try starting the engine; the engine should not crank.

Positioning the Seat

The seat can move forward and backward. Position the seat where you have the best control of the machine and are most comfortable (Figure 9).

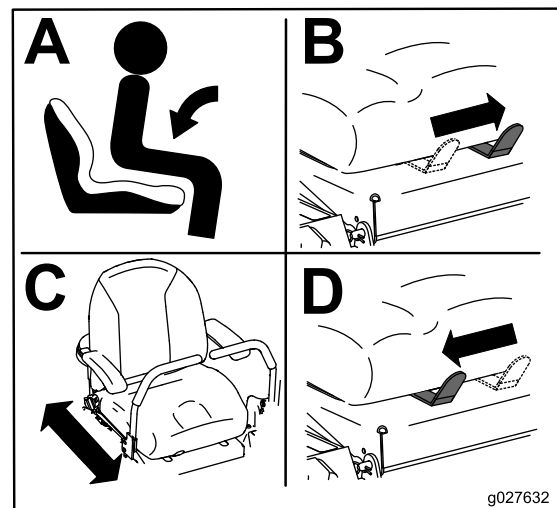

Figure 9

g027632

Adjusting the Motion-Control Levers

Adjusting the Height

You can adjust the motion-control levers higher or lower for maximum comfort (Figure 10).

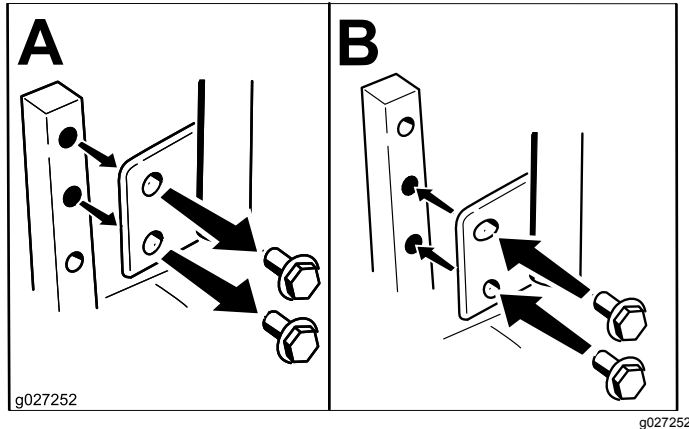

Figure 10

Adjusting the Tilt

You can adjust the motion-control levers forward or rearward for your comfort.

1. Loosen the upper bolt holding the control lever to the control-arm shaft.
2. Loosen the lower bolt just enough to pivot the control lever forward or rearward (Figure 10).
3. Tighten both bolts to secure the control lever in the new position.
4. Repeat the adjustment for the other control lever.

During Operation

During Operation Safety

General Safety

- The owner/operator can prevent and is responsible for accidents that may cause personal injury or property damage.
- Wear appropriate clothing, including eye protection; long pants; slip-resistant, substantial footwear; and hearing protection. Tie back long hair and do not wear jewelry.
- Do not operate the machine while ill, tired, or under the influence of alcohol or drugs.
- Never carry passengers on the machine and keep bystanders and pets away from the machine during operation.
- Operate the machine only in good visibility to avoid holes or hidden hazards.
- Avoid mowing on wet grass. Reduced traction could cause the machine to slide.
- Ensure that all drives are in neutral, the parking brake is engaged, and you are in the operating position before you start the engine.
- Keep your hands and feet away from the cutting units. Keep clear of the discharge opening at all times.
- Look behind and down before backing up to be sure of a clear path.
- Use care when approaching blind corners, shrubs, trees, or other objects that may obscure your vision.
- Do not mow near drop-offs, ditches, or embankments. The machine could suddenly roll over if a wheel goes over the edge or if the edge gives way.
- Stop the blades whenever you are not mowing.
- Stop the machine and inspect the blades after striking an object or if there is an abnormal vibration in the machine. Make all necessary repairs before resuming operation.
- Slow down and use caution when making turns and crossing roads and sidewalks with the machine. Always yield the right-of-way.
- Disengage the drive to the cutting unit and shut off the engine before adjusting the height of cut (unless you can adjust it from the operating position).
- Never run an engine in an area where exhaust gases are enclosed.
- Never leave a running machine unattended.

- Before leaving the operating position (including to empty the catchers or to unclog the chute), do the following:
 - Stop the machine on level ground.
 - Disengage the power take-off and lower the attachments.
 - Engage the parking brake.
 - Shut off the engine and remove the key.
 - Wait for all moving parts to stop.
- Do not operate the machine when there is the risk of lightning.
- Do not use the machine as a towing vehicle unless it has a hitch installed.
- Do not change the governor speed or overspeed the engine.
- Use only accessories and attachments approved by Toro.
- This machine produces sound levels in excess of 85 dBA at the operator's ear and can cause hearing loss through extended periods of exposure.

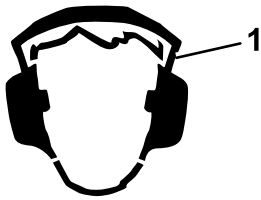

Figure 11

g229846

1. Wear hearing protection.

Slope Safety

- Slopes are a major factor related to loss of control and rollover accidents, which can result in severe injury or death. The operator is responsible for safe slope operation. Operating the machine on any slope requires extra caution. Before using the machine on a slope, do the following:
 - Review and understand the slope instructions in the manual and on the machine.
 - Use an angle indicator to determine the approximate slope angle of the area.
 - Never operate on slopes greater than 15 degrees.
 - Evaluate the site conditions of the day to determine if the slope is safe for machine operation. Use common sense and good judgment when performing this evaluation. Changes in the terrain, such as moisture, can quickly affect the operation of the machine on a slope.

- Identify hazards at the base of the slope. Do not operate the machine near drop offs, ditches, embankments, water, or other hazards. The machine could suddenly roll over if a wheel goes over the edge or the edge collapses. Keep a safe distance (twice the width of the machine) between the machine and any hazard. Use a walk behind machine or a hand trimmer to mow the grass in these areas.
- Avoid starting, stopping or turning the machine on slopes. Avoid making sudden changes in speed or direction; turn slowly and gradually.
- Do not operate a machine under any conditions where traction, steering or stability is in question. Be aware that operating the machine on wet grass, across slopes or downhill may cause the machine to lose traction. Loss of traction to the drive wheels may result in sliding and a loss of braking and steering. The machine can slide even if the drive wheels are stopped.
- Remove or mark obstacles such as ditches, holes, ruts, bumps, rocks, or other hidden hazards. Tall grass can hide obstacles. Uneven terrain could overturn the machine.
- Use extra care while operating with accessories or attachments, such as grass collection systems. These can change the stability of the machine and cause a loss of control. Follow directions for counterweights.
- If possible, keep the deck lowered to the ground while operating on slopes. Raising the deck while operating on slopes can cause the machine to become unstable.
- A 2-post ROPS (Rollover Protection System) is available for the machine as an accessory. A ROPS is recommended if you will be mowing next to drop-offs, near water, or on steep banks, which could result in a rollover. Contact an Authorized Service Dealer for more details. The California Code of Regulations requires ROPS (if available) on all mowers used commercially, effective March 1, 2011.

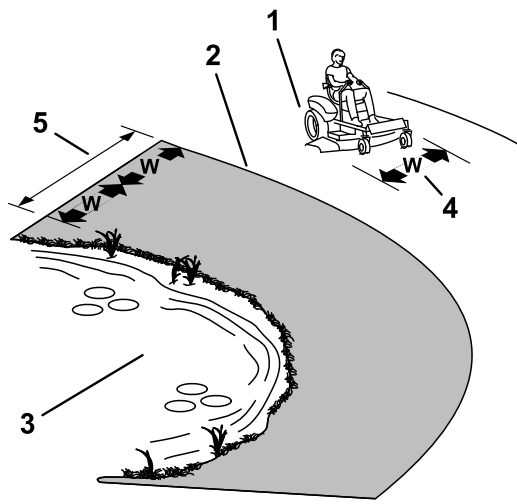

Figure 12

g229111

1. Safe Zone—use the machine here on slopes less than 15 degrees or flat areas.
2. Danger Zone—use a walk-behind mower and/or a hand trimmer on slopes greater than 15 degrees and near drop-offs or water.
3. Water
4. W=width of the machine
5. Keep a safe distance (twice the width of the machine) between the machine and any hazard.

Towing Safety

- Do not attach towed equipment except at the hitch point.
- Follow the attachment manufacturer's recommendation for weight limits for towed equipment and towing on slopes. The towed weight must not exceed the weight of the machine, operator, and ballast. Use counterweights or wheel weights as described in the attachment, or in the towing machine *Operator's Manual*.
- Never allow children or others near the towed equipment.
- On slopes, the weight of the towed equipment may cause loss of traction, increased risk of rollover, and loss of control. Reduce the towed weight and slow down.
- The stopping distance increases with the weight of a towed load. Travel slowly and allow extra distance to stop.
- Make wide turns to keep the attachment clear of the machine.

Operating the Parking Brake

Always engage the parking brake when you stop the machine or leave it unattended.

Engaging the Parking Brake

Park the machine on a level surface.

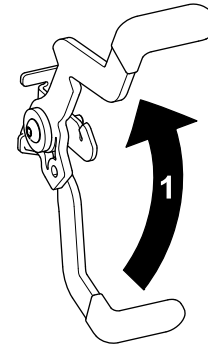

Figure 13

g188778

Disengaging the Parking Brake

To disengage the parking brake, pull the lever out of the detent slot and toward you, then push it down (Figure 14).

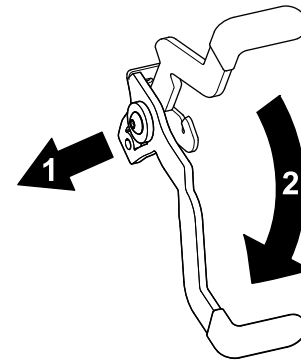

Figure 14

g188777

1. Push the parking brake out of the detent slot and toward you.
2. Push the parking brake down.

Operating the Mower Blade-Control Switch (PTO)

The blade-control switch (PTO) starts and stops the mower blades and any powered attachments.

Engaging the Blade-Control Switch (PTO)

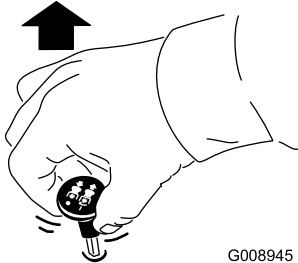

G008945

g008945

Figure 15

Note: Always engage the blades with the throttle in the FAST position (Figure 16).

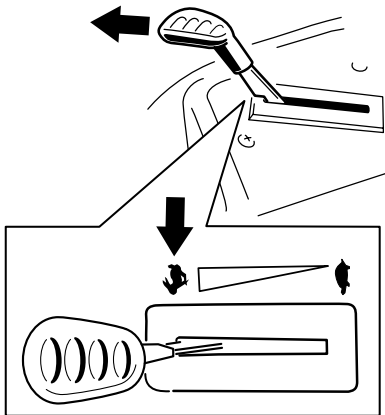

g187516

Figure 16

Disengaging the Blade-Control Switch (PTO)

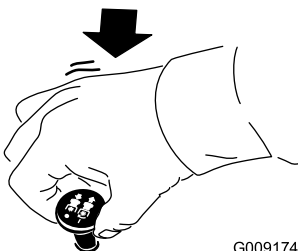

G009174

g009174

Figure 17

Operating the Throttle

You can move the throttle control between FAST and SLOW positions (Figure 18).

Always use the FAST position when engaging the PTO.

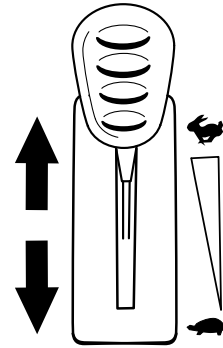

g187517

Figure 18

Operating the Choke

Use the choke to start a cold engine.

1. Pull up the choke knob to engage the choke before using the key switch (Figure 19).

Note: Ensure that you fully engage the choke. You may need to hold the knob up when you use the key switch.

2. Push down the choke to disengage the choke after the engine has started (Figure 19).

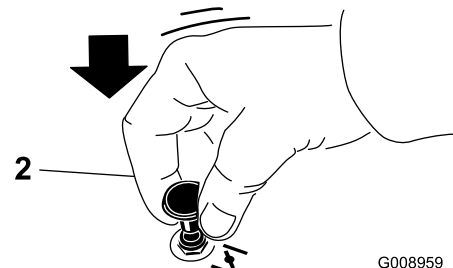
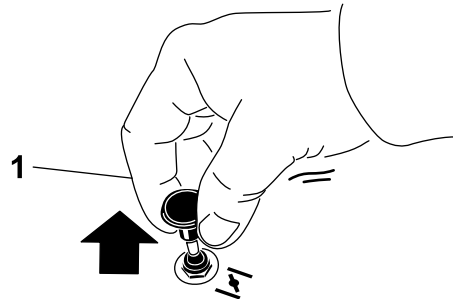

G008959

g008959

Figure 19

1. ON position

2. OFF position

Starting the Engine

Note: A warm or hot engine may not require choking.

Important: Do not engage the starter for more than 5 seconds at a time. Engaging the starter motor for more than 5 seconds can damage the starter motor. If the engine fails to start, wait 10 seconds before operating the engine starter again.

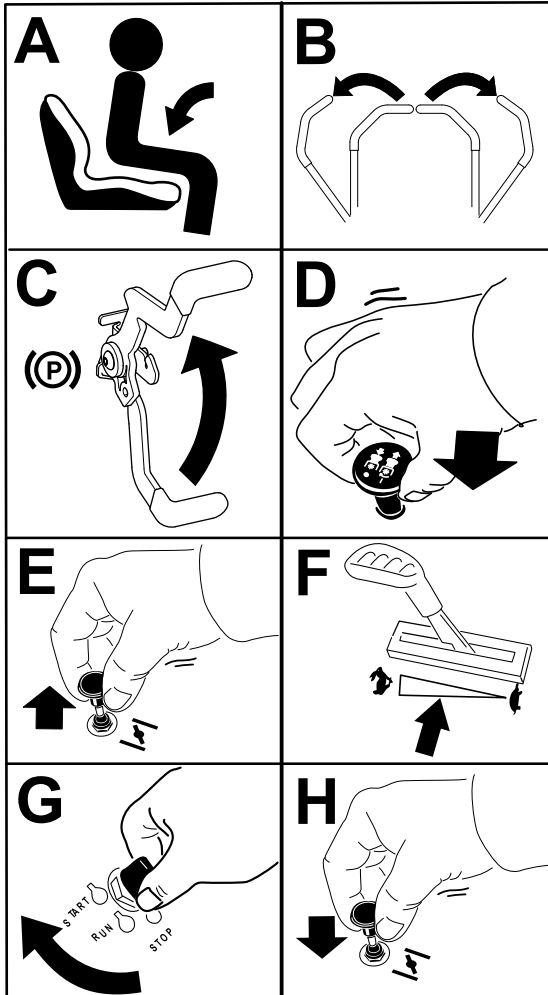

Figure 20

g189354

Shutting Off the Engine

1. Disengage the blades by moving the blade-control switch to the OFF position (Figure 17).
2. Engage the parking brake; refer to [Engaging the Parking Brake \(page 17\)](#).
3. Move the throttle control to the FAST position.
4. Turn the key to the OFF position and remove the key.

CAUTION

Children or bystanders may be injured if they move or attempt to operate the machine while it is unattended.

Always remove the key and engage the parking brake when leaving the machine unattended.

Using the Motion-Control Levers

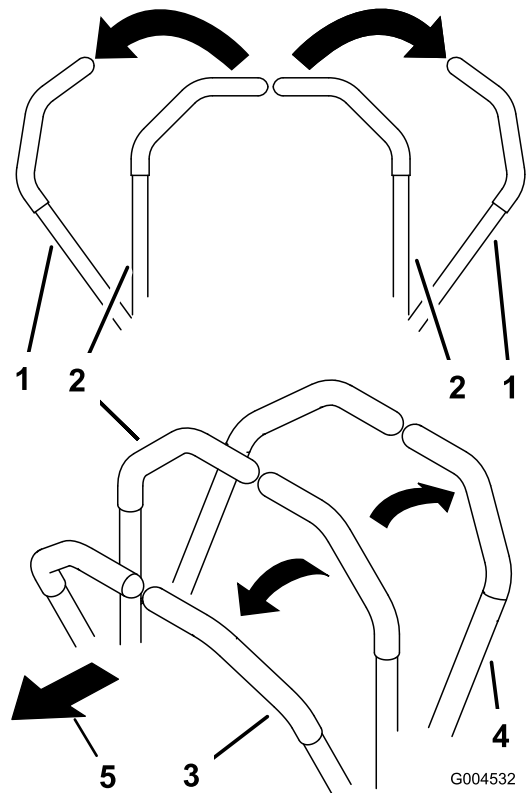

Figure 21

G004532

g004532

- | | |
|---|---------------------|
| 1. Motion-control lever—NEUTRAL-LOCK position | 4. Backward |
| 2. Center, unlocked position | 5. Front of machine |
| 3. Forward | |

Driving the Machine

The drive wheels turn independently, powered by hydraulic motors on each axle. You can turn 1 side in reverse while you turn the other forward, causing the machine to spin rather than turn. This greatly improves the machine maneuverability but may require some time for you to adapt to how it moves.

The throttle control regulates the engine speed as measured in rpm (revolutions per minute). Place the throttle control in the FAST position for best performance. Always operate in the full throttle position when mowing.

⚠ WARNING

The machine can spin very rapidly. You may lose control of the machine and cause personal injury or damage to the machine.

- Use caution when making turns.
- Slow the machine down before making sharp turns.

Driving Forward

Note: The engine shuts off when you move the traction-control with the parking brake engaged.

To stop the machine, pull the motion-control levers to the NEUTRAL position.

1. Disengage the parking brake; refer to [Disengaging the Parking Brake \(page 17\)](#).
2. Move the levers to the center, unlocked position.
3. To go forward, slowly push the motion-control levers forward ([Figure 22](#)).

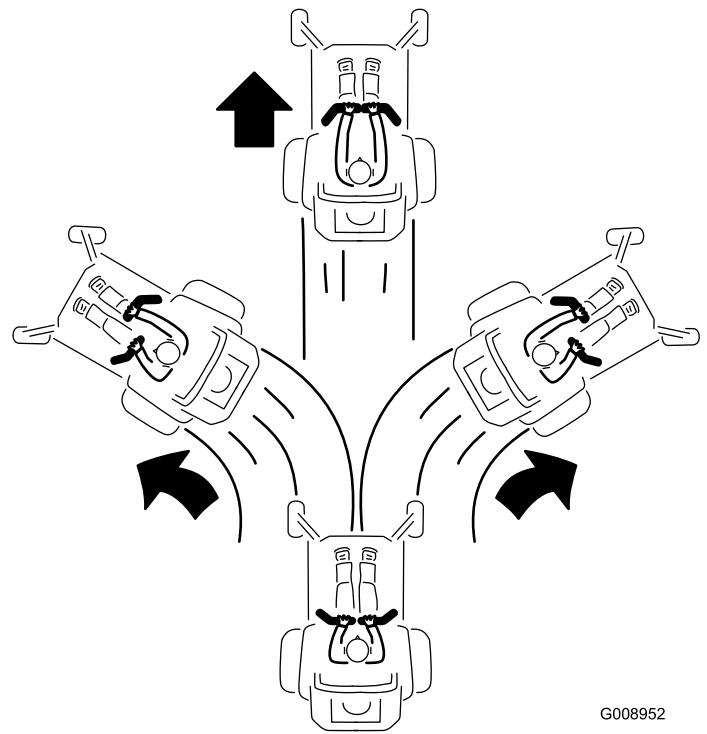

Figure 22

G008952
g008952

Driving Backward

1. Move the levers to the center, unlocked position.
2. To go backward, slowly pull the motion-control levers rearward ([Figure 23](#)).

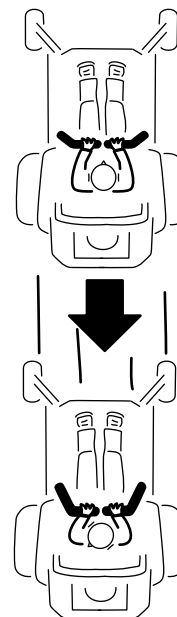

Figure 23

G008953
g008953

Using the Smart Speed™ Control System

The Smart Speed™ Control-System lever, located below the operating position (Figure 24), gives the operator a choice to drive the machine at 3 ground speed ranges—trim, tow, and mow.

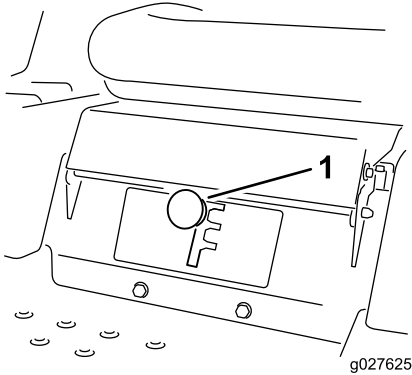

Figure 24

1. Smart-speed lever

To change speeds, do the following:

1. Move the motion-control levers to neutral and outward to the PARK position.
2. Disengage the blade-control switch.
3. Adjust the lever to the desired position.

The following are only recommendations for use. Adjustments vary by grass type, moisture content, and the height of the grass.

Suggested uses:	Trim	Tow	Mow
Parking	X		
Heavy, wet grass	X		
Training	X		
Bagging		X	
Mulching		X	
Normal mowing			X
Moving the machine			X

Trim

This is the lowest speed. The suggested uses for this speed are as follows:

- Parking
- Heavy, wet grass mowing conditions
- Training

Tow

This is the medium speed. The suggested uses for this speed are as follows:

- Bagging
- Mulching

Mow

This is the fastest speed. The suggested uses for this speed are as follows:

- Normal mowing
- Moving the machine

Using the Side Discharge

The mower has a hinged grass deflector that disperses clippings to the side and down toward the turf.

⚠ DANGER

Without a grass deflector, discharge cover, or a complete grass-catcher assembly mounted in place, you and others are exposed to blade contact and thrown debris. Contact with rotating mower blade(s) and thrown debris will cause injury or death.

- **Never remove the grass deflector from the mower deck because the grass deflector routes material down toward the turf. If the grass deflector is ever damaged, replace it immediately.**
- **Never put your hands or feet under the mower deck.**
- **Never try to clear the discharge area or mower blades unless you move the blade-control switch (PTO) to the OFF position, rotate the key switch to the OFF position, and remove the key from the key switch.**
- **Make sure that the grass deflector is in the down position.**

Adjusting the Height of Cut

The machine is equipped with a foot pedal deck-lift system. You can use the foot pedal to lift the deck briefly to avoid obstacles or lock the deck in the highest height of cut or transport position. You can use the height-of-cut lever with the foot pedal to lock the deck in a specific cutting height.

Using the Foot Pedal Deck-Lift System

- Press the deck-lift pedal down to raise the deck; continue to press the pedal until the deck locks in the transport position (Figure 25).
- Push on the deck-lift pedal with your foot and pull the transport lock handle rearward to disengage the transport lock (Figure 25).

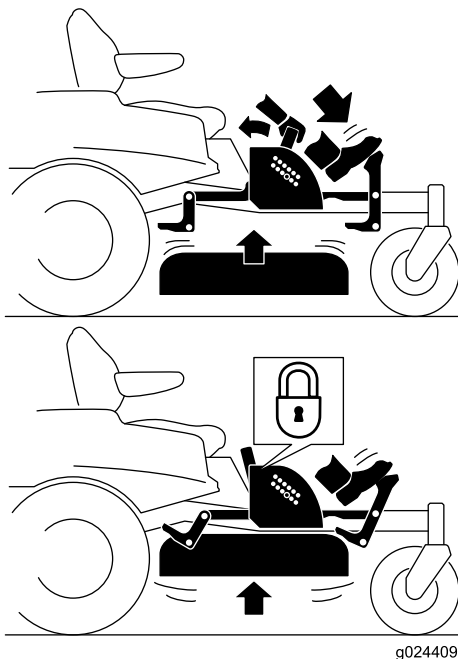

Figure 25

Transport Lock Position

Adjusting the Height of Cut

You can adjust the height of cut from 38 to 114 mm (1-1/2 to 4-1/2 inches) in 6 mm (1/4 inch) increments by moving the height-of-cut pin into different hole locations.

1. Push on the deck-lift pedal with your foot and raise the mower deck to the transport-lock position (also the 114 mm (4-1/2 inch) cutting height position) as shown in Figure 26.
2. To adjust, remove the pin from the height-of-cut bracket (Figure 26).

3. Select a hole in the height-of-cut system corresponding to the desired height of cut and insert the pin (Figure 26).
4. Push on the deck-lift pedal with your foot and pull the handle rearward to disengage the transport lock (Figure 25).
5. Lower the deck slowly until the lever makes contact with the pin.

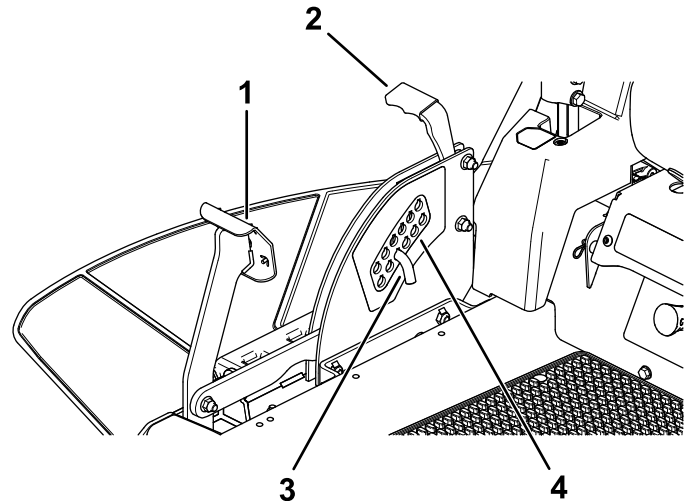

Figure 26

- | | |
|--------------------|----------------------------|
| 1. Deck-lift pedal | 3. Pin |
| 2. Handle | 4. Height-of-cut positions |

Adjusting the Anti-Scalp Rollers

Whenever you change the height of cut, adjust the height of the anti-scalp rollers.

Note: Adjust the anti-scalp rollers so that the rollers do not touch the ground in normal, flat mowing areas.

1. Park the machine on a level surface, disengage the blade-control switch and engage the parking brake; refer to [Engaging the Parking Brake](#) (page 17).
2. Shut off the engine, remove the key, and wait for all moving parts to stop before leaving the operating position.
3. Adjust the anti-scalp rollers as shown in [Figure 27](#).

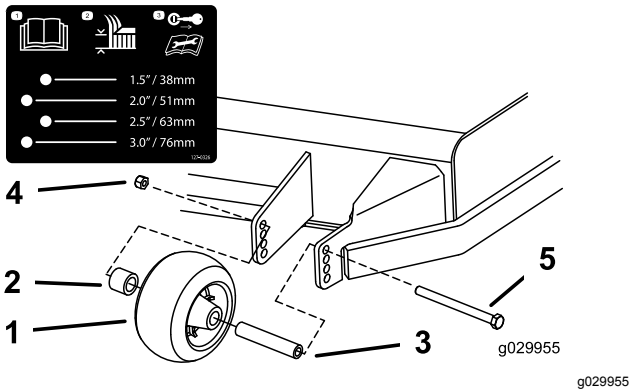

Figure 27

- | | |
|----------------------|---------------|
| 1. Anti-scalp roller | 4. Flange nut |
| 2. Spacer | 5. Bolt |
| 3. Bushing | |

Using Attachments and Accessories

Use only Toro approved attachments and accessories.

If you attach a bucket to the engine guard, use a nylon strap to secure it.

Important: If you are carrying more than 4.5 kg (10 lb) in a bucket attached to the engine guard, you should equip your machine with the Bucket-Support Kit.

Contact your authorized Toro service dealer.

Operating Tips

Using the Fast Throttle Setting

For best mowing and maximum air circulation, operate the engine at the FAST position. Air is required to thoroughly cut grass clippings, so do not set the height-of-cut so low as to totally surround the mower deck in uncut grass. Always try to have 1 side of the mower deck free from uncut grass, which allows air to be drawn into the mower deck.

Cutting a Lawn for the First Time

Cut grass slightly longer than normal to ensure that the cutting height of the mower deck does not scalp any uneven ground. However, the cutting height used in the past is generally the best one to use. When cutting grass longer than 15 cm (6 inches) tall, you may want to cut the lawn twice to ensure an acceptable quality of cut.

Cutting a Third of the Grass Blade

It is best to cut only about a third of the grass blade. Cutting more than that is not recommended unless grass is sparse, or it is late fall when grass grows more slowly.

Alternating the Mowing Direction

Alternate the mowing direction to keep the grass standing straight. This also helps disperse clippings, which enhances decomposition and fertilization.

Mowing at Correct Intervals

Grass grows at different rates at different times of the year. To maintain the same cutting height, mow more often in early spring. As the grass growth rate slows in mid summer, mow less frequently. If you cannot mow for an extended period, first mow at a high cutting height, then mow again 2 days later at a lower height setting.

Using a Slower Cutting Speed

To improve cut quality, use a slower ground speed in certain conditions.

Avoiding Cutting Too Low

When mowing uneven turf, raise the cutting height to avoid scalping the turf.

Stopping the Machine

If you must stop the forward motion of the machine while mowing, a clump of grass clippings may

drop onto your lawn. To avoid this, move onto a previously cut area with the blades engaged or you can disengage the mower deck while moving forward.

Keeping the Underside of the Mower Deck Clean

Clean clippings and dirt from the underside of the mower deck after each use. If grass and dirt build up inside the mower deck, cutting quality will eventually become unsatisfactory.

Maintaining the Blade(s)

Maintain a sharp blade throughout the cutting season because a sharp blade cuts cleanly without tearing or shredding the grass blades. Tearing and shredding turns grass brown at the edges, which slows growth and increases the chance of disease. Check the mower blades after each use for sharpness, and for any wear or damage. File down any nicks and sharpen the blades as necessary. If a blade is damaged or worn, replace it immediately with a genuine Toro replacement blade.

After Operation

After Operation Safety

General Safety

- Clean grass and debris from the cutting units, mufflers, and engine compartment to help prevent fires. Clean up oil or fuel spills.
- Shut off the fuel before storing or transporting the machine.
- Disengage the drive to the attachment whenever you are transporting or not using the machine.
- Allow the engine to cool before storing the machine in any enclosure.
- Never store the machine or fuel container where there is an open flame, spark, or pilot light, such as on a water heater or on other appliances.

Pushing the Machine by Hand

Important: Always push the machine by hand. Do not tow the machine, because towing may damage it.

This machine has an electric-brake mechanism, and to push the machine, the key must be in the RUN position. The battery needs to be charged and functioning to disengage the electric brake.

Pushing the Machine

1. Park the machine on a level surface, disengage the blade-control switch, and engage the parking brake.
2. Shut off the engine, remove the key, and wait for all moving parts to stop before leaving the operating position.
3. Locate the bypass levers on the frame on both sides of the engine.
4. Move the bypass levers forward through the key hole and down to lock them in place (Figure 28).

Note: Do this for each lever.

5. Turn the ignition key on and disengage the parking brake.

Note: Do not start the machine.

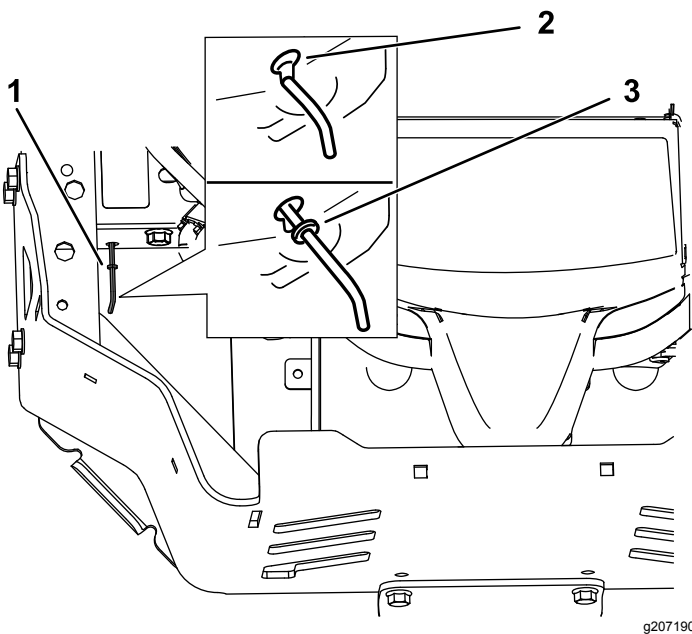

Figure 28

g207190

1. Bypass-lever locations
2. Lever position for operating the machine
3. Lever position for pushing the machine

6. When finished, ensure that the key has been returned to the STOP position to avoid draining the battery charge.

Operating the Machine

Move the bypass levers rearward through the keyhole and down to lock them in place as shown in [Figure 28](#).

Note: Do this for each lever.

Transporting the Machine

Use a heavy-duty trailer or truck to transport the machine. Use a full-width ramp. Ensure that the trailer or truck has all the necessary brakes, lighting, and marking as required by law. Please carefully read all the safety instructions. Knowing this information could help you or bystanders avoid injury. Refer to your local ordinances for trailer and tie-down requirements.

⚠ WARNING

Driving on the street or roadway without turn signals, lights, reflective markings, or a slow-moving-vehicle emblem is dangerous and can lead to accidents, causing personal injury.

Do not drive the machine on a public street or roadway.

Selecting a Trailer

⚠ WARNING

Loading a machine onto a trailer or truck increases the possibility of tip-over and could cause serious injury or death ([Figure 29](#)).

- Use only a full-width ramp; do not use individual ramps for each side of the machine.
- Do not exceed a 15-degree angle between the ramp and the ground or between the ramp and the trailer or truck.
- Ensure that the length of the ramp is at least 4 times as long as the height of the trailer or truck bed to the ground. This ensures that the ramp angle does not exceed 15 degrees on flat ground.

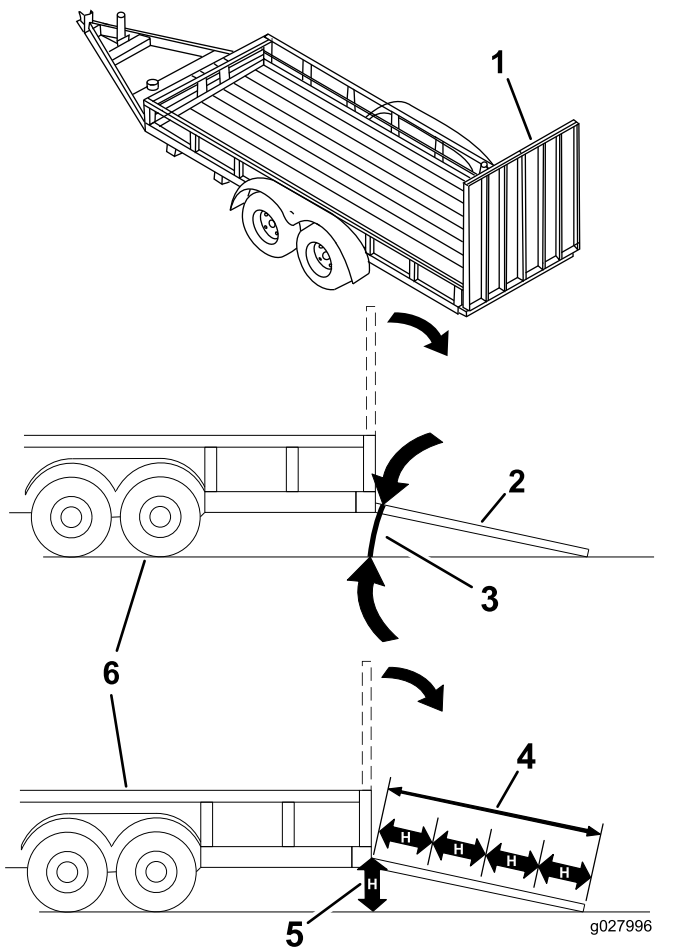

Figure 29

- | | |
|---|---|
| 1. Full-width ramp in stowed position | 4. Ramp is at least 4 times as long as the height of the trailer or truck bed to the ground |
| 2. Side view of full-width ramp in loading position | 5. H=height of the trailer or truck bed to the ground |
| 3. Not greater than 15 degrees | 6. Trailer |

Loading the Machine

⚠ WARNING

Loading a machine onto a trailer or truck increases the possibility of tip-over and could cause serious injury or death.

- Use extreme caution when operating a machine on a ramp.
- Back the machine up the ramp and drive it forward down the ramp.
- Avoid sudden acceleration or deceleration while driving the machine on a ramp as this could cause a loss of control or a tip-over situation.

1. If using a trailer, connect it to the towing vehicle and connect the safety chains.
2. If applicable, connect the trailer brakes and lights.
3. Lower the ramp, ensuring that the angle between the ramp and the ground does not exceed 15 degrees (Figure 29).
4. Back the machine up the ramp (Figure 30).

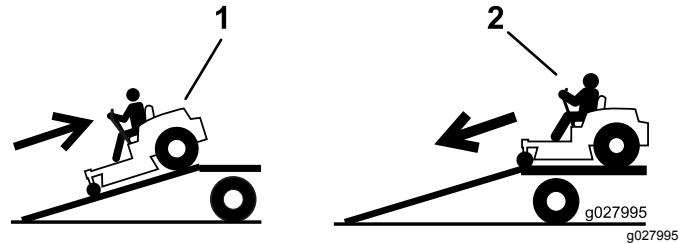

Figure 30

1. Back the machine up the ramp.
2. Drive the machine forward down the ramp.

5. Shut off the engine, remove the key, and engage the parking brake.
6. Tie down the machine near the front caster wheels and the rear bumper with straps, chains, cable, or ropes (Figure 31). Refer to local regulations for tie-down requirements.

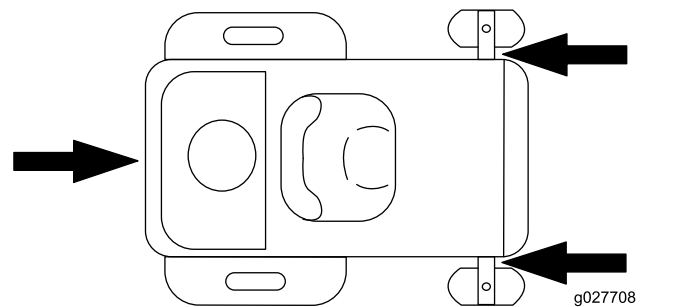

Figure 31

1. Tie-down loops

Unloading the Machine

1. Lower the ramp, ensuring that the angle between the ramp and the ground does not exceed 15 degrees (Figure 29).
2. Drive the machine forward down the ramp (Figure 30).

Maintenance

Note: Determine the left and right sides of the machine from the normal operating position.

Recommended Maintenance Schedule(s)

Maintenance Service Interval	Maintenance Procedure
After the first 5 hours	<ul style="list-style-type: none">• Change the engine oil and filter.
Before each use or daily	<ul style="list-style-type: none">• Check the safety-interlock system.• Check the air cleaner for dirty, loose, or damaged parts.• Check the engine-oil level.• Clean the air intake screen.• Inspect the blades.• Inspect the grass deflector for damage.
After each use	<ul style="list-style-type: none">• Clean the mower-deck housing.
Every 25 hours	<ul style="list-style-type: none">• Clean the air-cleaner foam element (more often in dusty, dirty conditions).• Check tire pressure.• Check the belts for wear or cracks.
Every 100 hours	<ul style="list-style-type: none">• Replace the air-cleaner foam element (more often in dusty, dirty conditions).• Clean the paper air-cleaner element (more often in dirty or dusty conditions).• Change the engine oil and oil filter (more often in dirty or dusty conditions).• Check the spark plug(s).• Check the in-line fuel filter.
Every 200 hours	<ul style="list-style-type: none">• Replace the paper air-cleaner element (more often in dirty or dusty conditions).• Replace the spark plug(s).• Replace the in-line fuel filter.
Before storage	<ul style="list-style-type: none">• Charge the battery and disconnect the battery cables.• Perform all maintenance procedures listed above before storage.• Paint any chipped surfaces.

▲ CAUTION

If you leave the key in the switch, someone could accidentally start the engine and seriously injure you or other bystanders.

Remove the key from the switch before you perform any maintenance.

Pre-Maintenance Procedures

Maintenance Safety

- Before repairing the machine do the following:
 - Disengage the drives.
 - Engage the parking brake.
 - Shut off the engine and remove the key.
 - Disconnect the spark-plug wire.
- Park the machine on a level surface.
- Clean grass and debris from the cutting unit, drives, mufflers, and engine to help prevent fires.
- Clean up oil or fuel spills.
- Do not allow untrained personnel to service the machine.
- Use jack stands to support the machine and/or components when required.
- Carefully release pressure from components with stored energy.
- Disconnect the battery or remove the spark-plug wire before making any repairs. Disconnect the negative terminal first and the positive terminal last. Connect the positive terminal first and negative last.
- Use care when checking the blades. Wrap the blade(s) or wear thickly padded gloves, and use caution when servicing them. Only replace blades; do not straighten or weld them.
- Keep your hands and feet away from moving parts. If possible, do not make adjustments with the engine running.
- Keep all parts in good working condition and all hardware tightened, especially the blade-attachment bolts. Replace all worn or damaged decals.
- Never interfere with the intended function of a safety device or reduce the protection provided by a safety device. Check their proper operation regularly.
- To ensure optimum performance and continued safety certification of the machine, use only genuine Toro replacement parts and accessories. Replacement parts and accessories made by other manufacturers could be dangerous, and such use could void the product warranty.
- Check the parking brake operation frequently. Adjust and service as required.

Engine Maintenance

Engine Safety

- Shut off the engine before checking the oil or adding oil to the crankcase.
- Keep your hands, feet, face, clothing, and other body parts away from the muffler and other hot surfaces.

Servicing the Air Cleaner

Service Interval: Before each use or daily

Note: Service the air cleaner more frequently (every few hours) if operating conditions are extremely dusty or sandy.

Removing the Foam and Paper Elements

1. Park the machine on a level surface, disengage the blade-control switch (PTO), and engage the parking brake.
2. Shut off the engine, remove the key, and wait for all moving parts to stop before leaving the operating position.
3. Clean around the air-cleaner cover to prevent dirt from getting into the engine and causing damage.
4. Lift the cover and rotate the air-cleaner assembly out of the engine ([Figure 32](#)).

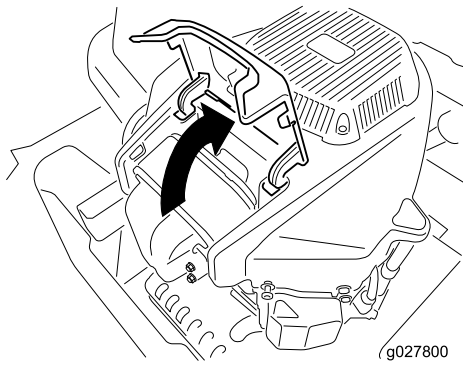

g027800

g027800

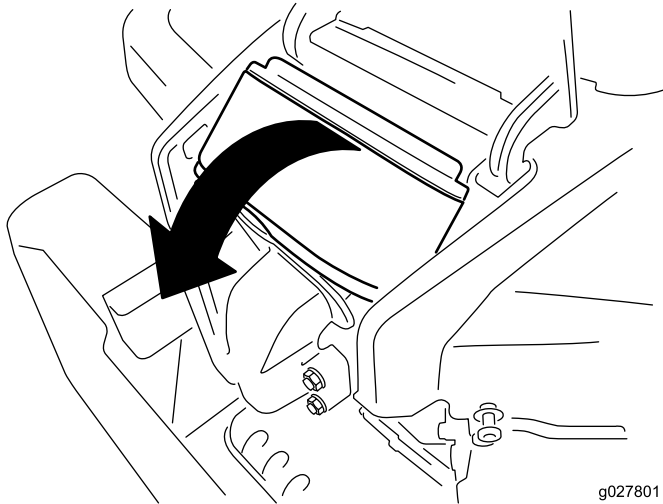

g027801

g027801

Figure 32

5. Separate the foam and paper elements ([Figure 33](#)).

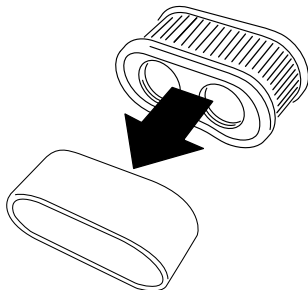

g027802

g027802

Figure 33

Servicing the Foam Air-Cleaner Element

Service Interval: Every 25 hours/Monthly (whichever comes first)—Clean the air-cleaner foam element (more often in dusty, dirty conditions).

Every 100 hours/Yearly (whichever comes first)—Replace the air-cleaner foam element (more often in dusty, dirty conditions).

1. Wash the foam element in liquid soap and warm water. When the element is clean, rinse it thoroughly.
2. Dry the element by squeezing it in a clean cloth.

Important: Replace the foam element if it is torn or worn.

Servicing the Paper Air-Cleaner Element

Service Interval: Every 100 hours—Clean the paper air-cleaner element (more often in dirty or dusty conditions).

Every 200 hours—Replace the paper air-cleaner element (more often in dirty or dusty conditions).

1. Clean the paper element by tapping it gently to remove dust.

Note: If it is very dirty, replace the paper element with a new one.

2. Inspect the element for tears, an oily film, or damage to the rubber seal.
3. Replace the paper element if it is damaged.

Important: Do not clean the paper filter.

Changing the Engine Oil and Oil Filter

Service Interval: After the first 5 hours/After the first month (whichever comes first)—Change the engine oil and filter.

Every 100 hours/Yearly (whichever comes first)—Change the engine oil and oil filter (more often in dirty or dusty conditions).

1. Park the machine on a level surface to ensure that the oil drains completely.
2. Disengage the blade-control switch (PTO) and engage the parking brake.
3. Shut off the engine, remove the key, and wait for all moving parts to stop before leaving the operating position.
4. Drain the oil from the engine.

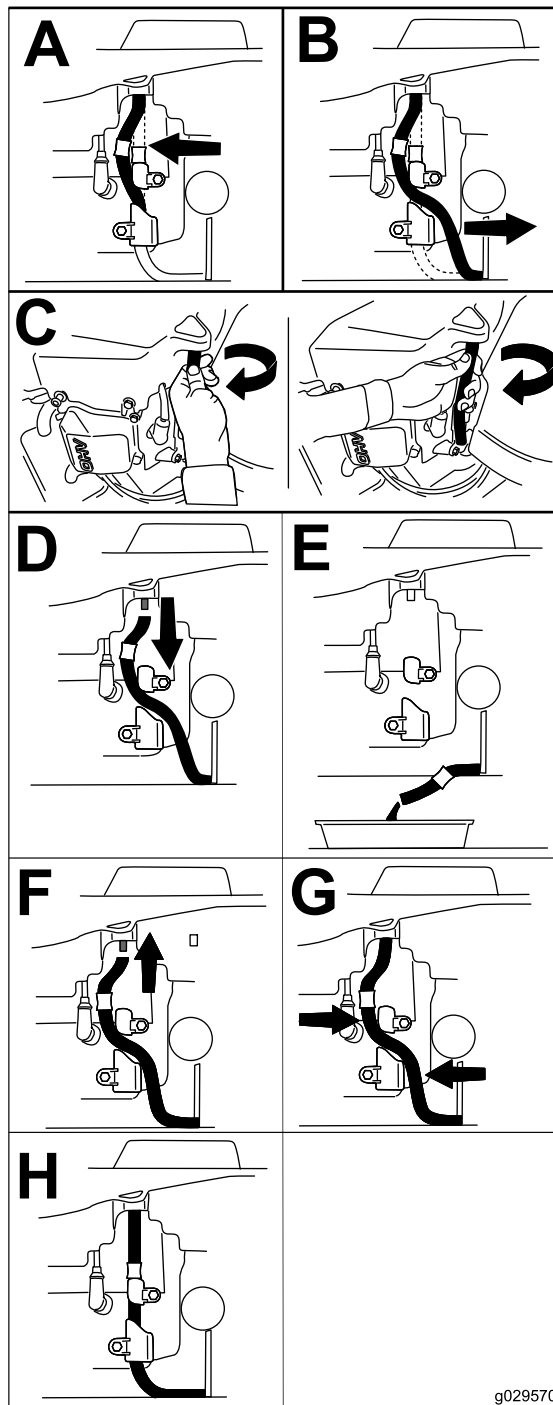
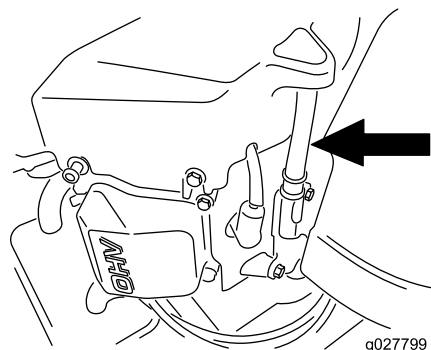

Figure 37

5. Change the engine-oil filter (Figure 38).

Note: Ensure that the oil-filter gasket touches the engine and then turn the filter an extra 3/4 turn.

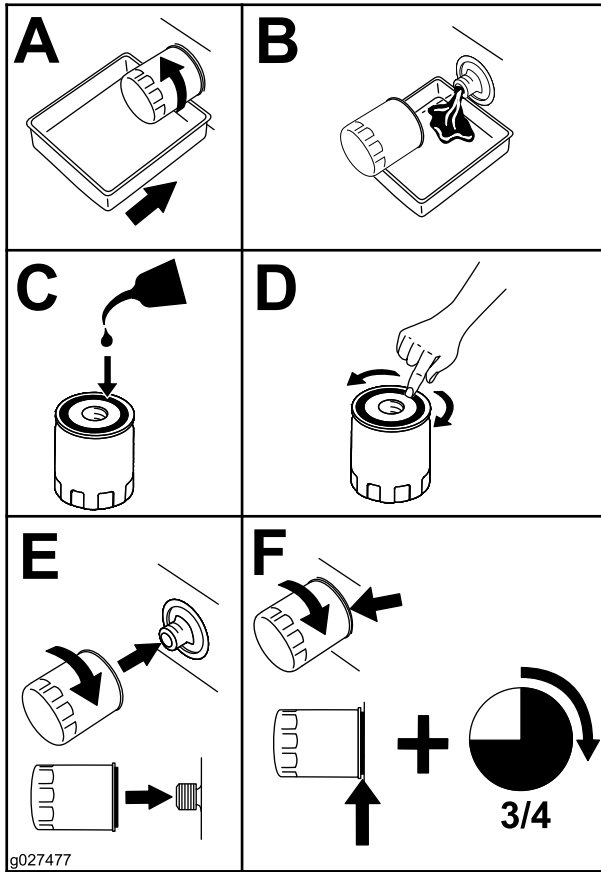

Figure 38

6. Slowly pour approximately 80% of the specified oil into the filler tube and slowly add the additional oil to bring it to the Full mark (Figure 39).

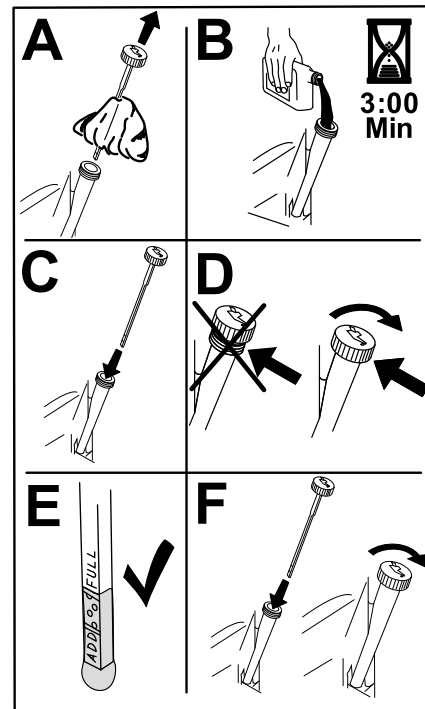

Figure 39

7. Dispose of the used oil at a recycling center.

Servicing the Spark Plug

Service Interval: Every 100 hours/Yearly (whichever comes first)—Check the spark plug(s).

Every 200 hours/Every 2 years (whichever comes first)—Replace the spark plug(s).

Ensure that the air gap between the center and side electrodes is correct before installing the spark plug. Use a spark plug wrench for removing and installing the spark plug and a gapping tool or feeler gauge to check and adjust the air gap. Install a new spark plug if necessary.

Type: Champion® RN9YC or NGK® BPR6ES

Air gap: 0.76 mm (0.03 inch)

Removing the Spark Plug

1. Park the machine on a level surface, disengage the blade-control switch (PTO), and engage the parking brake.
2. Shut off the engine, remove the key, and wait for all moving parts to stop before leaving the operating position.
3. Clean the area around the base of the plug to keep dirt and debris out of the engine.
4. Remove the spark plug (Figure 40).

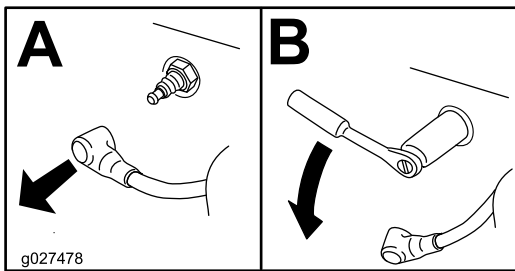

Figure 40

Cleaning the Cooling System

1. Park the machine on a level surface, disengage the blade-control switch (PTO), and engage the parking brake.
2. Shut off the engine, remove the key, and wait for all moving parts to stop before leaving the operating position.
3. Remove the air filter from the engine.
4. Remove the engine shroud.
5. To prevent debris entering the air intake, install the air filter to the filter base.
6. Clean debris and grass from the parts.
7. Remove the air filter and install the engine shroud.
8. Install the air filter.

Checking the Spark Plug

Important: Do not clean the spark plug(s). Always replace the spark plug(s) when it has a black coating, worn electrodes, an oily film, or cracks.

If you see light brown or gray on the insulator, the engine is operating properly. A black coating on the insulator usually means the air cleaner is dirty.

Set the gap to 0.75 mm (0.03 inch).

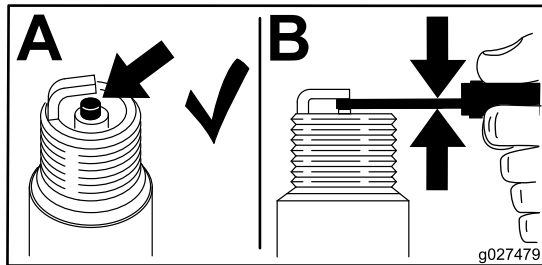

Figure 41

Installing the Spark Plug

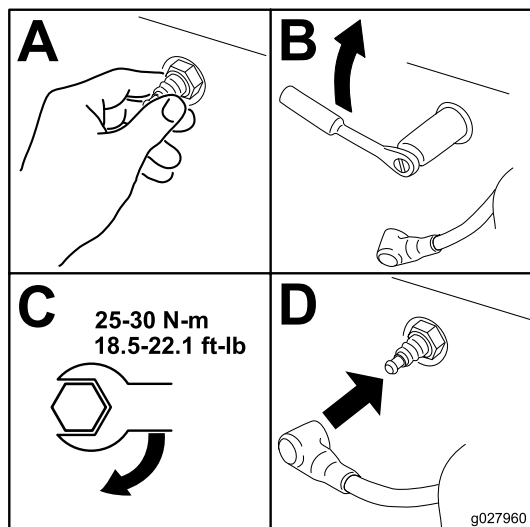

Figure 42

Fuel System Maintenance

⚠ DANGER

In certain conditions, fuel is extremely flammable and highly explosive. A fire or explosion from fuel can burn you, others, and can damage property.

- Perform any fuel-related maintenance when the engine is cold. Do this outdoors in an open area. Wipe up any fuel that spills.
- Never smoke when draining fuel, and stay away from an open flame or where a spark may ignite the fuel fumes.

Replacing the In-Line Fuel Filter

Service Interval: Every 100 hours/Yearly (whichever comes first)—Check the in-line fuel filter.

Every 200 hours/Every 2 years (whichever comes first)—Replace the in-line fuel filter.

Never install a dirty filter after removing it from the fuel line.

1. Park the machine on a level surface, disengage the blade-control switch (PTO), and engage the parking brake.
2. Shut off the engine, remove the key, and wait for all moving parts to stop before leaving the operating position.
3. Replace the filter ([Figure 43](#)).

Note: Note: Ensure that the markings on the filter follow the fuel flow direction.

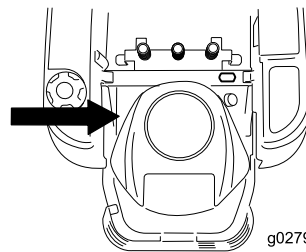

g027939

g027939

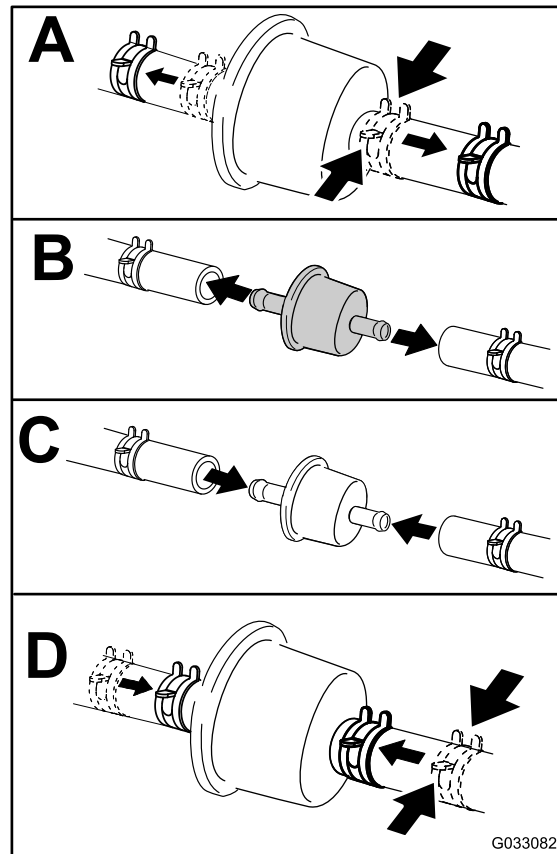

G033082

g033082

Figure 43

Electrical System Maintenance

Electrical System Safety

- Disconnect the battery before repairing the machine. Disconnect the negative terminal first and the positive last. Connect the positive terminal first and the negative last.
- Charge the battery in an open, well-ventilated area, away from sparks and flames. Unplug the charger before connecting or disconnecting the battery. Wear protective clothing and use insulated tools.

WARNING

CALIFORNIA Proposition 65 Warning

Battery posts, terminals, and related accessories contain lead and lead compounds, chemicals known to the State of California to cause cancer and reproductive harm. Wash hands after handling.

Servicing the Battery

Removing the Battery

⚠ WARNING

Incorrectly removing the cables from battery could damage the machine and cables, causing sparks. Sparks can cause the battery gasses to explode, resulting in personal injury.

- Always disconnect the negative (black) battery cable before disconnecting the positive (red) cable.
 - Always connect the positive (red) battery cable before connecting the negative (black) cable.
1. Park the machine on a level surface, disengage the blade-control switch (PTO), and engage the parking brake.
 2. Shut off the engine, remove the key, and wait for all moving parts to stop before leaving the operating position.
 3. Loosen the 2 fasteners on the battery cover counterclockwise 1/4 turn, and remove the battery cover (Figure 44).

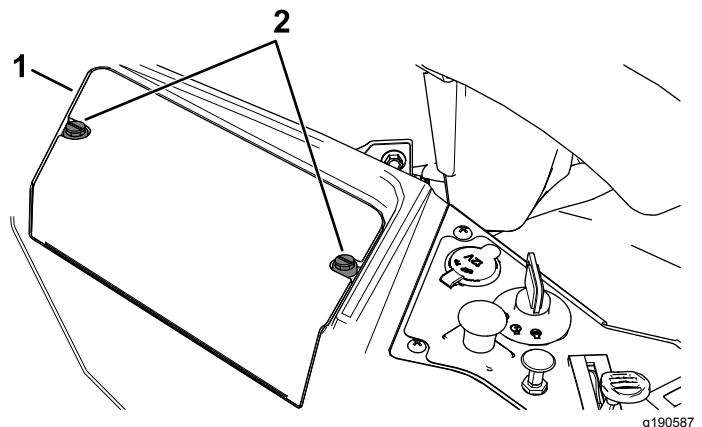

Figure 44

1. Battery cover
2. Fasteners

4. Disconnect the negative (black) ground cable from the battery post (Figure 45).

Note: Retain all fasteners.

5. Slide the rubber cover up the positive (red) cable.
6. Disconnect the positive (red) cable from the battery post (Figure 45).

Note: Retain all fasteners.

7. Remove the battery hold-down (Figure 45), and lift the battery from the battery tray.

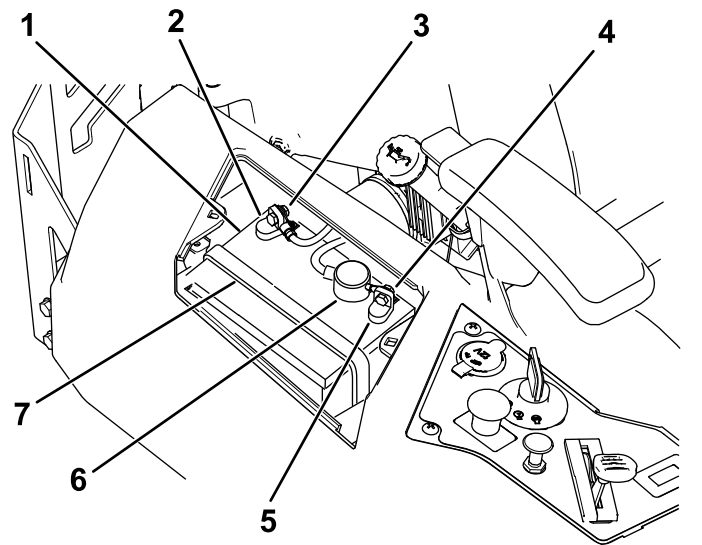

Figure 45

1. Battery
2. Negative (-) battery post
3. Bolt, washer, and nut for the negative (-) battery post
4. Bolt, washer, and nut for the positive (+) battery post
5. Positive (+) battery post
6. Terminal boot
7. Battery hold-down

Charging the Battery

Service Interval: Before storage—Charge the battery and disconnect the battery cables.

1. Remove the battery from the chassis; refer to [Removing the Battery \(page 35\)](#).
2. Charge the battery for a minimum of 1 hour at 6 to 10 A.

Note: Do not overcharge the battery.

3. When the battery is fully charged, unplug the charger from the electrical outlet, then disconnect the charger leads from the battery posts ([Figure 46](#)).

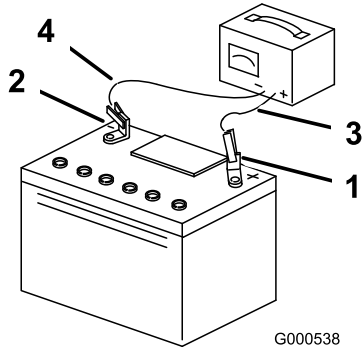

Figure 46

- | | |
|------------------------------|---------------------------|
| 1. Positive (+) battery post | 3. Red (+) charger lead |
| 2. Negative (-) battery post | 4. Black (-) charger lead |

Installing the Battery

1. Position the battery in the tray ([Figure 45](#)).
2. Using the fasteners previously removed, install the positive (red) battery cable to the positive (+) battery terminal.
3. Using the fasteners previously removed, install the negative battery cable to the negative (-) battery terminal.
4. Slide the red terminal boot onto the positive (red) battery post.
5. Secure the battery with the hold-down ([Figure 45](#)).
6. Install the battery cover by pushing down and tightening the 2 fasteners clockwise ([Figure 44](#)).

Servicing the Fuses

The electrical system is protected by fuses. It requires no maintenance; however, if a fuse blows, check the component/circuit for a malfunction or short.

Fuse type:

- Main—F1 (15 A, blade-type)
- Charge Circuit—F2 (25 A, blade-type)

To replace the Main (15 A) fuse, reach into the opening in the side of the console, pull out the fuse, and install a new 15 A fuse ([Figure 47](#)).

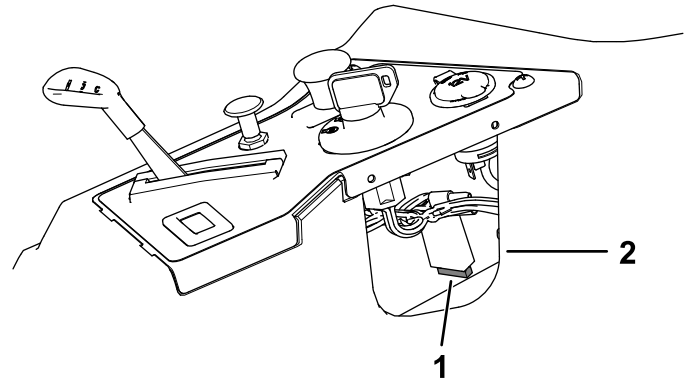

Figure 47

- | | |
|----------------|--------------------|
| 1. Main (15 A) | 2. Console opening |
|----------------|--------------------|

To replace the Charge Circuit (25 A) fuse, locate the fuse to the left of battery, pull out the fuse, and install a new 25 A fuse ([Figure 48](#)).

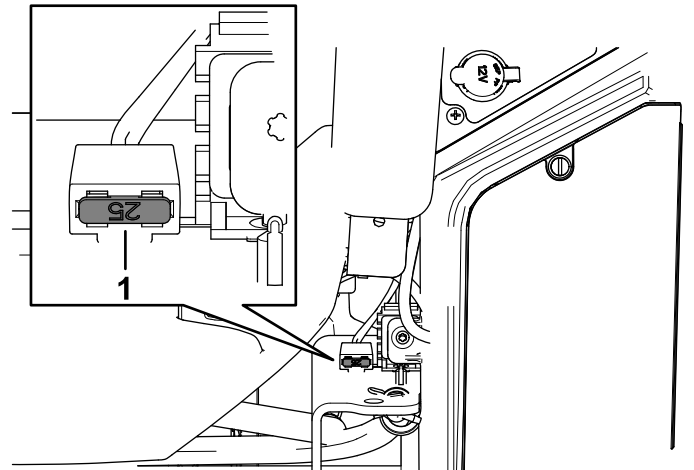

Figure 48

- | |
|--------------------------|
| 1. Charge circuit (25 A) |
|--------------------------|

Drive System Maintenance

Checking the Tire Pressure

Service Interval: Every 25 hours—Check tire pressure.

Maintain the air pressure in the front and rear tires as specified. Uneven tire pressure can cause uneven cut. Check the pressure at the valve stem (Figure 49). Check the tires when they are cold to get the most accurate pressure reading.

Refer to the maximum pressure suggested by the tire manufacturer on the sidewall of the caster wheel tires.

Inflate the front caster wheel tires to 103 kPa (15 psi).

Inflate the rear drive wheel tires to 90 kPa (13 psi).

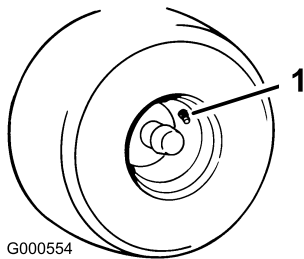

Figure 49

1. Valve stem

Mower Maintenance

Servicing the Cutting Blades

To ensure a superior quality of cut, keep the blades sharp. For convenient sharpening and replacement, keep extra blades on hand.

Blade Safety

A worn or damaged blade can break, and a piece of the blade could be thrown toward you or bystanders, resulting in serious personal injury or death. Trying to repair a damaged blade may result in discontinued safety certification of the product.

- Inspect the blades periodically for wear or damage.
- Use care when checking the blades. Wrap the blades or wear gloves, and use caution when servicing the blades. Only replace or sharpen the blades; never straighten or weld them.
- On multi-bladed machines, take care as rotating 1 blade can cause other blades to rotate.

Before Inspecting or Servicing the Blades

1. Park the machine on a level surface, disengage the blade-control switch (PTO), and engage the parking brake.
2. Shut off the engine, remove the key, and disconnect the spark-plug wires from the spark plugs.

Inspecting the Blades

Service Interval: Before each use or daily

1. Inspect the cutting edges (Figure 50).
2. If the edges are not sharp or have nicks, remove and sharpen the blade; refer to [Sharpening the Blades \(page 39\)](#).
3. Inspect the blades, especially in the curved area.
4. If you notice any cracks, wear, or a slot forming in this area, immediately install a new blade (Figure 50).

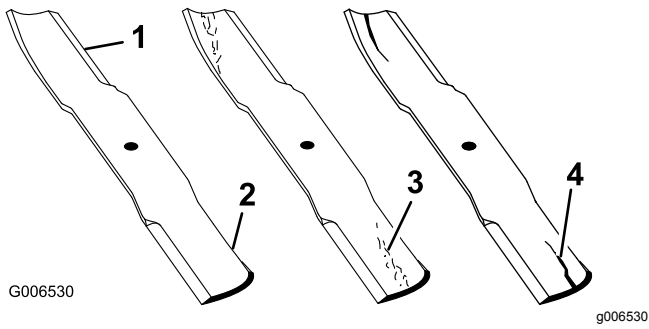

Figure 50

- | | |
|-----------------|----------------------|
| 1. Cutting edge | 3. Wear/slot forming |
| 2. Curved area | 4. Crack |

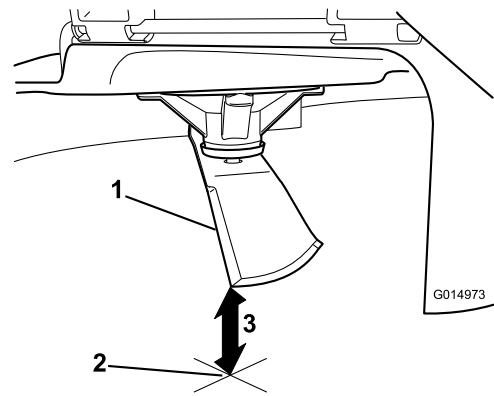

Figure 52

1. Blade (in position for measuring)
2. Level surface
3. Measured distance between blade and the surface (A)

Checking for Bent Blades

Note: The machine must be on a level surface for the following procedure.

1. Raise the mower deck to the highest height-of-cut position.
2. While wearing thickly padded gloves, or other adequate hand protection, slowly rotate the blade into a position that allows you to measure the distance between the cutting edge and the level surface the machine is on (Figure 51).

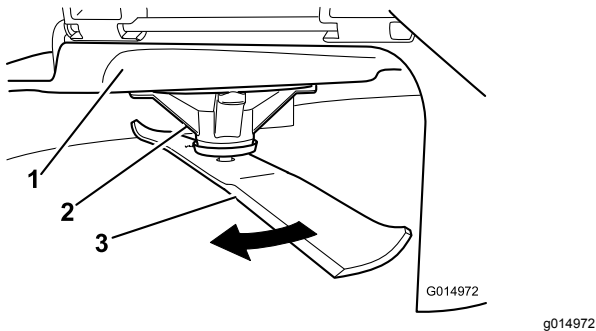

Figure 51

- | | |
|--------------------|----------|
| 1. Deck | 3. Blade |
| 2. Spindle housing | |

3. Measure from the tip of the blade to the flat surface (Figure 52).

4. Rotate the same blade 180 degrees so that the opposing cutting edge is now in the same position (Figure 53).

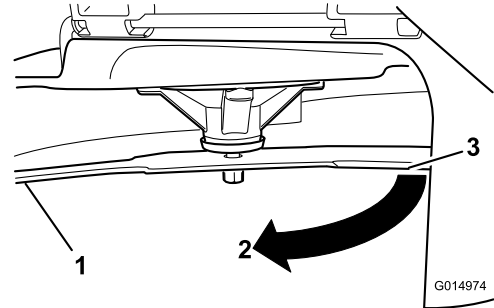

Figure 53

- | |
|---|
| 1. Blade (side previously measured) |
| 2. Measurement (position used previously) |
| 3. Opposing side of blade being moved into measurement position |

5. Measure from the tip of the blade to the flat surface (Figure 54).

Note: The variance should be no more than 3 mm (1/8 inch).

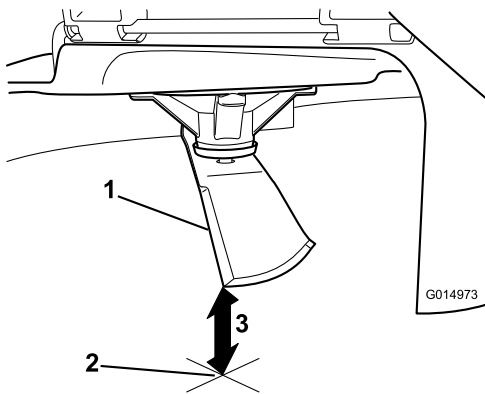

Figure 54

1. Opposite blade edge (in position for measuring)
2. Level surface
3. Second measured distance between blade and surface (B)

A. If the difference between A and B is greater than 3 mm (1/8 inch), replace the blade with a new blade; refer to [Removing the Blades \(page 39\)](#) and [Installing the Blades \(page 40\)](#).

Note: If a bent blade is replaced with a new blade, and the dimension obtained continues to exceed 3 mm (1/8 inch), the blade spindle could be bent. Contact an Authorized Service Dealer for service.

B. If the variance is within constraints, move to the next blade.

6. Repeat this procedure on each blade.

Removing the Blades

Replace the blades if they hit a solid object, or if the blade is out of balance or bent.

1. Hold the blade end using a rag or thickly padded glove.
2. Remove the blade bolt, curved washer, and blade from the spindle shaft ([Figure 55](#)).

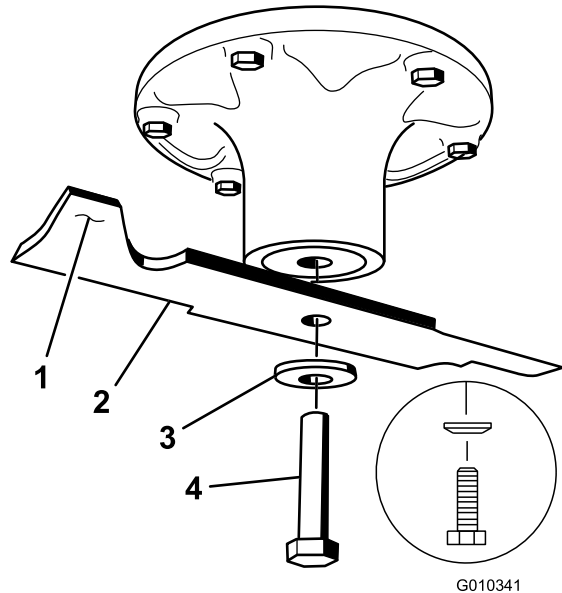

Figure 55

1. Sail area of the blade
2. Blade
3. Curved washer
4. Blade bolt

Sharpening the Blades

1. Use a file to sharpen the cutting edge at both ends of the blade ([Figure 56](#)).

Note: Maintain the original angle.

Note: The blade retains its balance if the same amount of material is removed from both cutting edges.

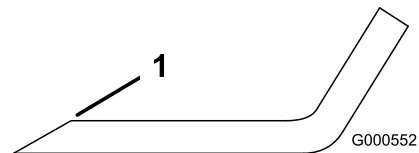

Figure 56

1. Sharpen at original angle.
2. Check the balance of the blade by putting it on a blade balancer ([Figure 57](#)).

Note: If the blade stays in a horizontal position, the blade is balanced and can be used.

Note: If the blade is not balanced, file some metal off the end of the sail area only ([Figure 56](#)).

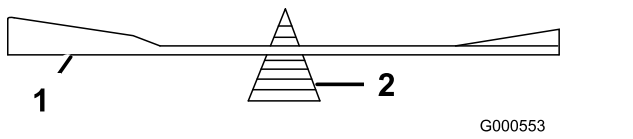

Figure 57

1. Blade
2. Balancer

3. Repeat this procedure until the blade is balanced.

Installing the Blades

1. Install the blade onto the spindle shaft (Figure 55).

Important: The curved part of the blade must be pointing upward toward the inside of the mower to ensure proper cutting.

2. Install the curved washer (cupped side toward the blade) and the blade bolt (Figure 55).
3. Torque the blade bolt to 135 to 150 N·m (100 to 110 ft-lb).

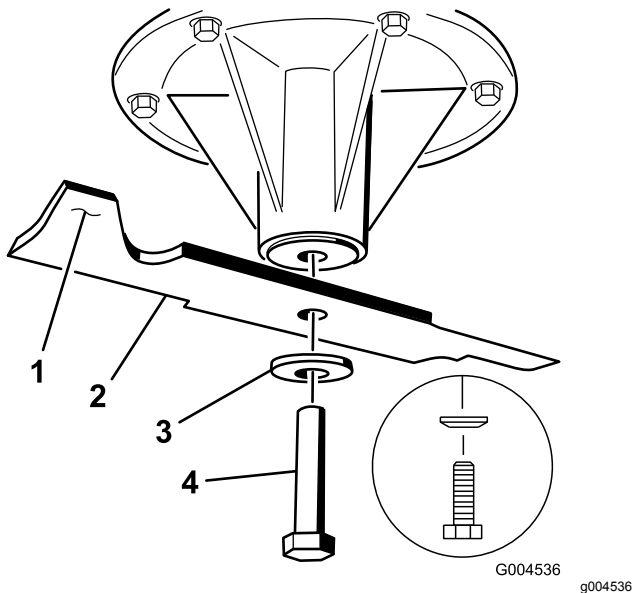

Figure 58

1. Sail area of the blade
2. Blade
3. Curved washer
4. Blade bolt

Leveling the Mower Deck

Check to ensure that the mower deck is level any time you install the mower or when you see an uneven cut on your lawn.

Check the mower deck for bent blades prior to leveling, and remove and replace any bent blades; refer to [Servicing the Cutting Blades \(page 37\)](#) before continuing.

Level the mower deck side-to-side first; then you can adjust the front-to-rear slope.

Requirements:

- The machine must be on a level surface.
- All tires must be properly inflated; refer to [Checking the Tire Pressure \(page 37\)](#).

Checking the Side-to-Side Level

1. Park the machine on a level surface, disengage the blade-control switch (PTO), and engage the parking brake.
2. Shut off the engine, remove the key, and wait for all moving parts to stop before leaving the operating position.
3. Carefully rotate the blades side to side.
4. Measure between the outside cutting edges and the flat surface (Figure 59).

Note: If both measurements are not within 5 mm (3/16 inch), an adjustment is required; refer to [Leveling the Mower Deck \(page 41\)](#).

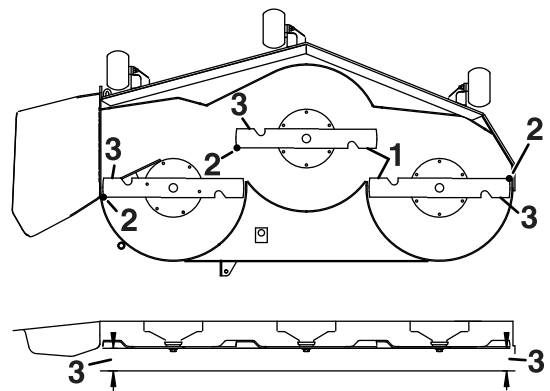

Figure 59

1. Blades side to side
2. Outside cutting edges
3. Measure from the tip of the blade to the flat surface here.

Checking the Front-to-Rear Blade Slope

Check the front-to-rear blade level any time you install the mower. If the front of the mower is more than 7.9 mm (5/16 inch) lower than the rear of the mower, adjust the blade level.

1. Park the machine on a level surface, disengage the blade-control switch (PTO), and engage the parking brake.
2. Shut off the engine, remove the key, and wait for all moving parts to stop before leaving the operating position.
3. Carefully rotate the blades so they are facing front to rear (Figure 60).
4. Measure from the tip of the front blade to the flat surface and the tip of the rear blade to the flat surface (Figure 60).

Note: If the front blade tip is not 1.6 to 7.9 mm (1/16 to 5/16 inch) lower than the rear blade tip, continue to the [Leveling the Mower Deck](#) (page 41) procedure.

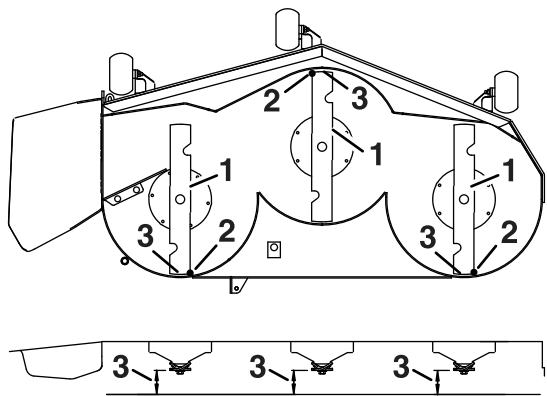

Figure 60

g229304

1. Blades front to rear
2. Outside cutting edges
3. Measure from the tip of the blade to the flat surface here.

Leveling the Mower Deck

1. Set the anti-scalp rollers to the top holes or remove them completely for this procedure; refer to [Adjusting the Anti-Scalp Rollers](#) (page 22).
2. Set the height-of-cut lever to the 76 mm (3 inch) position; refer to [Adjusting the Height of Cut](#) (page 22).
3. Place 2 blocks, each having a thickness of 6.6 cm (2-5/8 inches), under each side of the front edge of the deck but not under the anti-scalp roller brackets (Figure 61).
4. Place 2 blocks, each having a thickness of 7.3 cm (2-7/8 inches), under the rear edge of the cutting deck skirt, 1 on each side of the cutting deck (Figure 61).

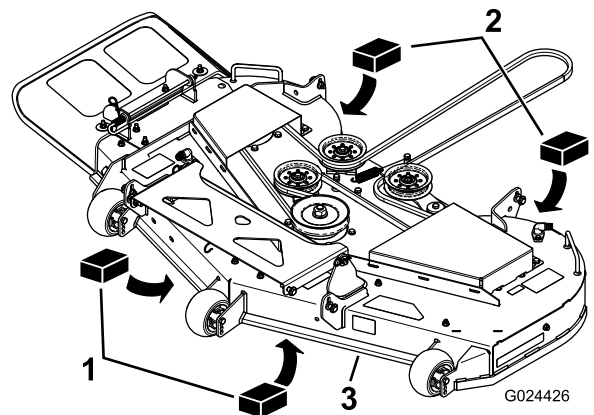

Figure 61

g024428

1. Wood block—6.6 cm (2-5/8 inches) thick
 2. Wood block—7.3 cm (2-7/8 inches) thick
 3. Front edge
-
5. Loosen the adjustment bolts on all 4 corners so that the deck is sitting securely on all 4 blocks (Figure 62).

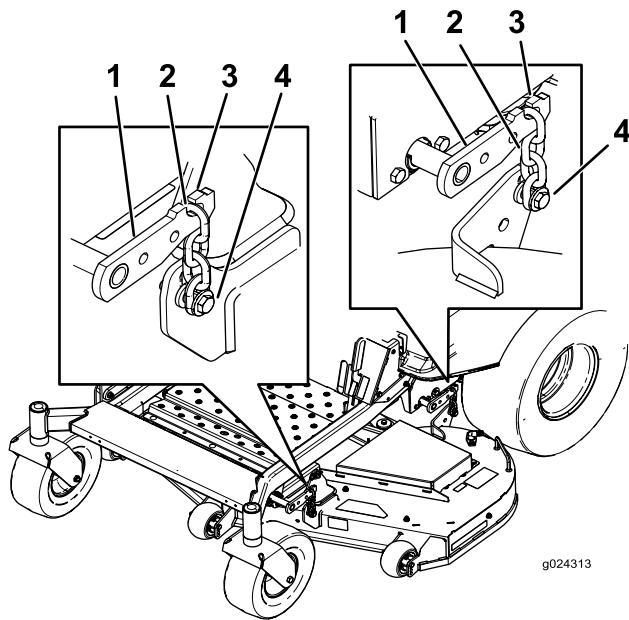

Figure 62

- | | |
|------------------|--------------------|
| 1. Deck-lift arm | 3. Hook |
| 2. Chain | 4. Adjustment bolt |

6. Ensure that there is tension on all 4 chains (Figure 62).
7. Tighten the 4 adjustment bolts (Figure 62).
8. Ensure that the blocks fit snugly under the deck skirt and that all bolts are tight.
9. Verify that the deck is level by checking the side-to-side level and front-to-rear blade slope; repeat the deck leveling procedure if necessary.

Removing the Mower Deck

1. Park the machine on a level surface, disengage the blade-control switch (PTO), and engage the parking brake.
2. Shut off the engine, remove the key, and disconnect the spark-plug wires from the spark plugs.
3. Lower the mower to the 76 mm (3 inches) height-of-cut position.
4. Remove the mower belt from the engine pulley; refer to [Replacing the Mower Belt \(page 44\)](#).
5. Remove the hairpin cotter and washer securing the link pin to the frame and deck, and remove the link bar (Figure 63).

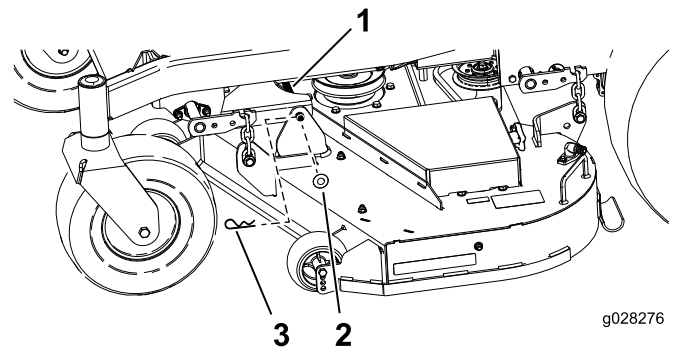

Figure 63

- | | |
|-------------|-------------------|
| 1. Link pin | 3. Hairpin cotter |
| 2. Washer | |

6. Lift up the mower deck to relieve tension from the mower deck.
7. Remove the chains from the hooks on the deck-lift arms (Figure 64).

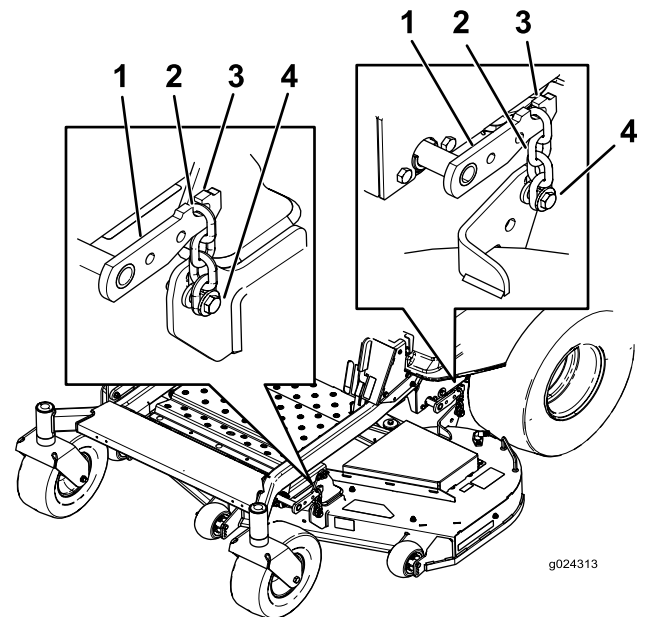

Figure 64

- | | |
|------------------|--------------------|
| 1. Deck-lift arm | 3. Hook |
| 2. Chain | 4. Adjustment bolt |

8. Raise the height of cut to the transport position.
9. Remove the belt from the clutch pulley on the engine.
10. Slide the mower out from underneath the machine.

Note: Retain all parts for future installation.

Installing the Mower Deck

1. Park the machine on a level surface, disengage the blade-control switch (PTO), and engage the parking brake.
2. Shut off the engine, remove the key, and disconnect the spark-plug wires from the spark plugs.
3. Slide the mower under the machine.
4. Lower the height-of-cut lever to the lowest position.
5. Place the height-of-cut pin in the lock position for lowest height of cut.
6. Lift the rear of the mower deck and attach the chains to the rear lift arms (Figure 64).
7. Attach the front chains to the front lift arms (Figure 64).
8. Install the long link bar through the frame hanger and deck.
9. Secure the link pin with the hairpin cotters and washers removed previously (Figure 63).
10. Install the mower belt onto the engine pulley; refer to [Replacing the Mower Belt](#) (page 44).

Replacing the Grass Deflector

Service Interval: Before each use or daily—Inspect the grass deflector for damage.

⚠ WARNING

An uncovered discharge opening could allow the lawn mower to throw objects toward you or bystanders, resulting in serious injury. Also, contact with the blade could occur. Never operate the machine without the grass deflector, the discharge cover, or the grass-collection system in place.

Never operate the machine without the grass deflector, the discharge cover, or the grass-collection system in place.

1. Disengage the spring from the notch in the deflector bracket and slide the rod out of the welded deck brackets, spring, and discharge deflector (Figure 65).

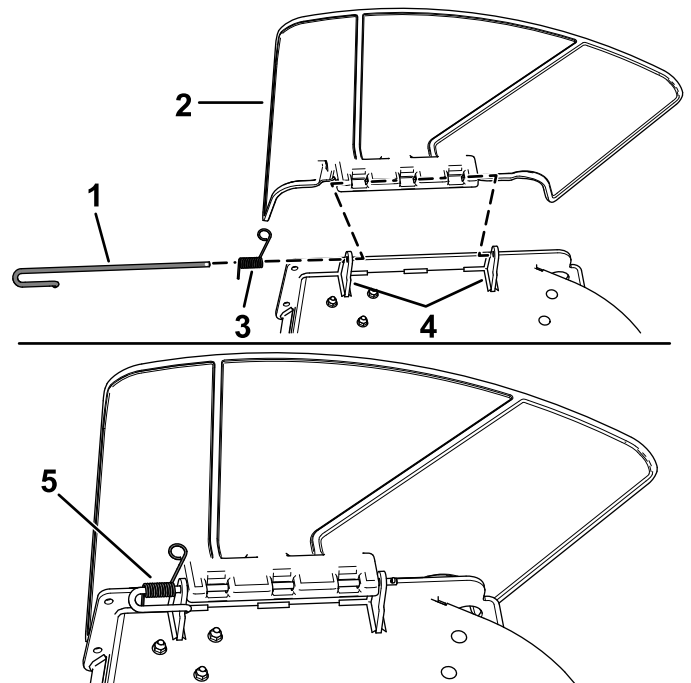

Figure 65

g197127

- | | |
|--------------|----------------------------------|
| 1. Rod | 4. Deck brackets |
| 2. Spring | 5. Spring installed over the rod |
| 3. Deflector | |

2. Remove the damaged or worn discharge deflector.
3. Position the new discharge deflector with the bracket ends between the welded brackets on the deck as shown in [Figure 66](#).

4. Install the spring onto the straight end of the rod.
5. Position the spring on the rod as shown in [Figure 66](#) so that the shorter spring end comes from under the rod before the bend and going over the rod as it returns from the bend.
6. Lift the loop end of the spring and place it into the notch on the deflector bracket ([Figure 66](#)).

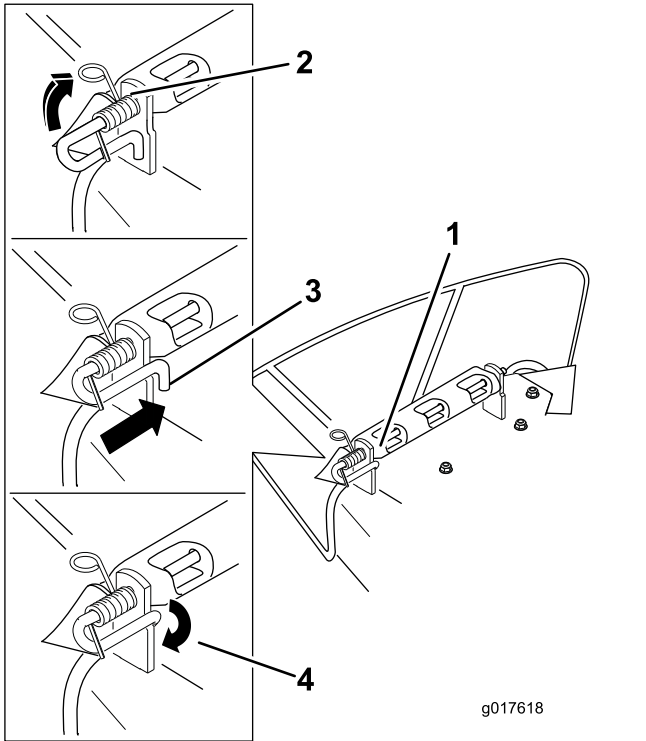

Figure 66

- | | |
|---|---|
| 1. Rod and spring assembly installed | 3. Rod, short end, moved behind the mower bracket |
| 2. Loop end of the spring installed into the notch in the deflector bracket | 4. Short end, retained by mower bracket. |

7. Secure the rod and spring assembly by twisting it so that the short end of the rod is behind the front bracket welded to the deck ([Figure 66](#)).

Important: The grass deflector must be spring loaded in the down position. Lift the deflector up to test that it snaps to the full down position.

Mower Belt Maintenance

Inspecting the Belts

Service Interval: Every 25 hours—Check the belts for wear or cracks.

Replace the belt if it is worn. The signs of a worn belt include squealing while the belt is rotating; the blades slipping while cutting grass; and frayed edges, burn marks, and cracks on the belt.

Replacing the Mower Belt

The signs of a worn belt include squealing while the belt is rotating, blades slipping while cutting grass, and frayed edges, burn marks, and cracks on the belt. Replace the mower belt if any of these conditions are evident.

1. Park the machine on a level surface, disengage the blade-control switch (PTO), and engage the parking brake.
2. Shut off the engine, remove the key, and wait for all moving parts to stop before leaving the operating position.
3. Lower the mower to the 76 mm (3 inches) height-of-cut position.
4. For each of the belt covers, loosen the 2 bolts, **but do not remove them.**
5. Slide the cover until it is clear of the bolts and lift it up and out to remove it.
6. Remove the floor pan to access the idler pulley.
7. Using a spring removal tool, (Toro Part No. 92-5771), remove the idler spring from the deck post to remove tension on the idler pulley ([Figure 67](#)).

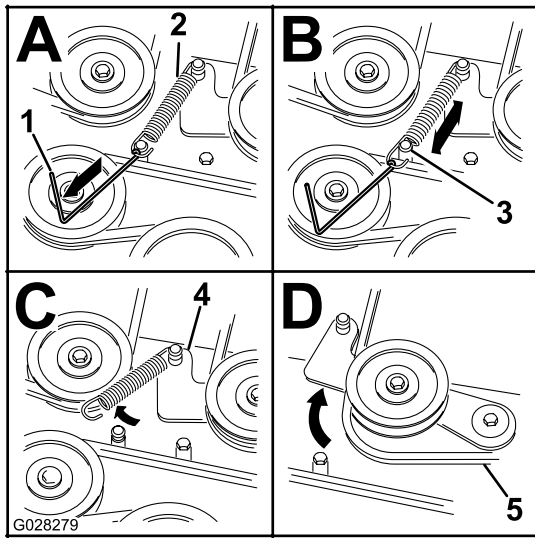

Figure 67

- | | |
|--|---------------|
| 1. Spring-removal tool (Toro Part No. 92-5771) | 4. Idler arm |
| 2. Idler spring | 5. Mower belt |
| 3. Deck post | |

- Lower the mower to the lowest height of cut and place the height-of-cut pin in the lock position for the lowest height-of-cut.
- Remove the belt from the mower-deck pulleys and remove the existing belt.
- Install the new belt around the mower pulleys and the clutch pulley under the engine (Figure 67).

⚠ WARNING

The spring is under tension when installed and can cause personal injury.

Be careful when removing the belt.

- Using a spring-removal tool, (Toro Part No. 92-5771), install the idler spring over the deck post and placing tension on the idler pulley and mower belt (Figure 67).
- Ensure that the belt is properly seated in all pulleys.
- To install the belt covers, insert the tabs on the each cover into the corresponding slots on the deck bracket, ensuring that they seat.
- Rotate the cover to the deck and slide the notches under the loosened bolts until they are seated.
- Tighten the bolts to secure the cover to the deck.

Cleaning

Washing the Underside of the Mower

Service Interval: After each use—Clean the mower-deck housing.

Important: You can wash the machine with a mild detergent and water. Do not pressure wash the machine. Avoid excessive use of water, especially near the control panel, under the seat, around the engine, hydraulic pumps, and motors.

Wash the underside of the mower deck after each use to prevent grass buildup for improved mulch action and clipping dispersal.

- Park the machine on a level surface, disengage the blade-control switch (PTO), and engage the parking brake.
- Shut off the engine, remove the key, and wait for all moving parts to stop before leaving the operating position.
- Attach the hose coupling to the end of the mower washout fitting, and turn the water on high (Figure 68).

Note: Spread petroleum jelly on the washout fitting O-ring to make the coupling slide on easier and protect the O-ring.

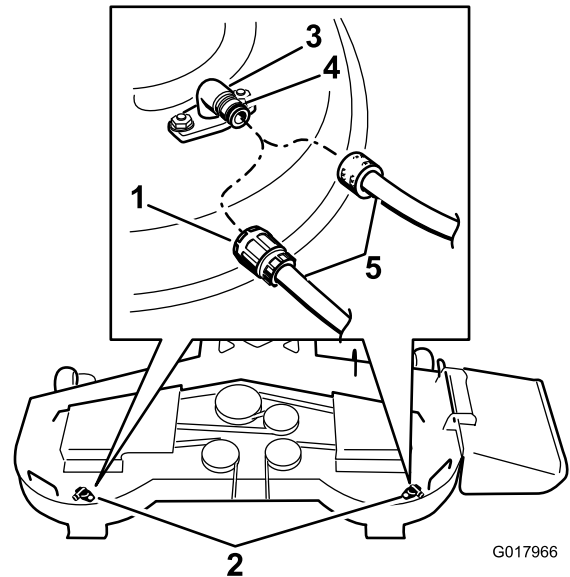

Figure 68

- | | |
|---|-----------|
| 1. Washout fitting locations on 54-inch decks | 4. O-ring |
| 2. Washout fitting locations on 48-inch decks | 5. Hose |
| 3. Washout fitting | |

- Lower the mower to the lowest height of cut.

5. Sit on the seat and start the engine.
6. Engage the blade-control switch and let the mower run for 1 to 3 minutes.
7. Disengage the blade-control switch (PTO), shut off the engine, remove the key from the key switch, and wait for all moving parts to stop.
8. Turn the water off and remove the coupling from the washout fitting.

Note: If the mower is not clean after 1 washing, soak it and let it stand for 30 minutes. Then, repeat the process.

9. Run the mower again for 1 to 3 minutes to remove excess water.

⚠ WARNING

A broken or missing washout fitting could expose you and others to thrown objects or blade contact. Contact with a blade or thrown debris can cause injury or death.

- **Replace broken or missing washout fitting immediately, before using machine again.**
- **Never put your hands or feet under the mower or through openings in the machine.**

Disposing of Waste

Engine oil, batteries, hydraulic fluid, and engine coolant are pollutants to the environment. Dispose of these according to your state and local regulations.

Storage

Storage Safety

- Let the engine cool before storing the machine.
- Do not store the machine or fuel near flames or drain the fuel indoors.

Cleaning and Storage

1. Disengage the blade-control switch (PTO), and engage the parking brake.
2. Shut off the engine, remove the key, and wait for all moving parts to stop before leaving the operating position.
3. Remove grass clippings, dirt, and grime from the external parts of the entire machine, especially the engine and hydraulic system. Clean dirt and chaff from the outside of the engine cylinder head fins and blower housing.

Important: You can wash the machine with mild detergent and water. Do not pressure wash the machine. Avoid excessive use of water, especially near the control panel, engine, hydraulic pumps, and motors.

4. Check the parking brake operation; refer to [Operating the Parking Brake \(page 17\)](#).
5. Service the air cleaner; refer to [Servicing the Air Cleaner \(page 28\)](#).
6. Change the crankcase oil; refer to [Changing the Engine Oil and Oil Filter \(page 31\)](#).
7. Check the tire pressure; refer to [Checking the Tire Pressure \(page 37\)](#).
8. Charge the battery; refer to [Charging the Battery \(page 36\)](#).
9. Scrape any heavy buildup of grass and dirt from the underside of the mower, then wash the mower with a garden hose.

Note: Run the machine with the blade-control switch (PTO) engaged and the engine at high idle for 2 to 5 minutes after washing.

10. Check the condition of the blades; refer to [Servicing the Cutting Blades \(page 37\)](#).
11. Prepare the machine for storage when non-use occurs over 30 days. Prepare the machine for storage as follows:
 - A. Add a petroleum-based stabilizer/conditioner to fuel in the tank. Follow mixing instructions from the stabilizer manufacturer. Do not use an alcohol-based stabilizer (ethanol or methanol).

Note: A fuel stabilizer/conditioner is most effective when mixed with fresh fuel and used at all times.

- B. Run the engine to distribute conditioned fuel through the fuel system (5 minutes).
- C. Shut off the engine, allow it to cool, and drain the fuel tank.
- D. Start the engine and run it until it stops.
- E. Dispose of fuel properly. Recycle the fuel according to local codes.

Important: Do not store stabilizer/conditioned fuel over 90 days.

12. Remove and check the condition of the spark plug(s); refer to [Servicing the Spark Plug \(page 32\)](#). With the spark plug(s) removed from the engine, pour 30 ml (2 tablespoons) of engine oil into the spark plug hole. Use the starter to crank the engine and distribute the oil inside the cylinder. Install the spark plug(s). Do not install the wire on the spark plug(s).
13. Check and tighten all bolts, nuts, and screws. Repair or replace any part that is damaged.
14. Paint all scratched or bare metal surfaces. Paint is available from your Authorized Service Dealer.
15. Store the machine in a clean, dry garage or storage area. Remove the key from the switch and keep it out of reach of children or other unauthorized users. Cover the machine to protect it and keep it clean.

Storing the Battery

1. Fully charge the battery.
2. Let the battery rest for 24 hours, then check the battery voltage.

Note: If the battery voltage is below 12.6 V, repeat steps 1 and 2.

3. Disconnect the cables from the battery.
4. Check the voltage periodically to ensure that the voltage is 12.4 V or higher.

Note: If the battery voltage is below 12.4 V, repeat steps 1 and 2.

Battery Storage Tips

- Store the battery in a cool, dry area in an upright position.
- Do not stack batteries directly on top of each other, unless they are in cartons.
- Do not stack more than 3 batteries (only 2 if the battery type is commercial).
- Test a wet battery every 4 to 6 months and charge it, if necessary.
- Always test and charge the battery before installation.

Troubleshooting

Problem	Possible Cause	Corrective Action
The fuel tank is showing signs of collapsing or the machine is frequently showing signs of running out of fuel.	1. The air-cleaner paper element clogged.	1. Clean the paper element.
The engine overheats.	1. The engine load is excessive. 2. The oil level in the crankcase is low. 3. The cooling fins and air passages under the engine-blower housing are plugged. 4. The air cleaner is dirty. 5. Dirt, water, or stale fuel is in the fuel system.	1. Reduce the ground speed. 2. Add oil to the crankcase. 3. Remove the obstruction from the cooling fins and air passages. 4. Clean or replace the air-cleaner element. 5. Contact an Authorized Service Dealer
The starter does not crank.	1. The blade-control switch is engaged. 2. The motion-control levers are not in the NEUTRAL-LOCK position. 3. The battery is dead. 4. The electrical connections are corroded or loose. 5. A fuse is blown. 6. A relay or switch is damaged.	1. Disengage the blade-control switch. 2. Move the motion-control levers outward to the NEUTRAL-LOCK position. 3. Charge the battery. 4. Check the electrical connections for good contact. 5. Replace the fuse. 6. Contact an Authorized Service Dealer.
The engine does not start, starts hard, or fails to keep running.	1. The fuel tank is empty. 2. The choke (if applicable) is not on. 3. The air cleaner is dirty. 4. The spark-plug wire(s) is loose or disconnected. 5. The spark plug(s) is pitted, fouled, or the gap is incorrect. 6. There is dirt in fuel filter. 7. Dirt, water, or stale fuel is in fuel system. 8. There is incorrect fuel in the fuel tank. 9. The oil level in the crankcase is low.	1. Fill the fuel tank. 2. Move the choke lever to the ON position. 3. Clean or replace the air-cleaner element. 4. Install the wire(s) on the spark plug. 5. Install a new, correctly gapped spark plug(s). 6. Replace the fuel filter. 7. Contact an Authorized Service Dealer. 8. Drain the tank and replace the fuel with the proper type. 9. Add oil to the crankcase.
The engine loses power.	1. The engine load is excessive. 2. The air cleaner is dirty. 3. The oil level in the crankcase is low. 4. The cooling fins and air passages under the engine blower housing are plugged. 5. The spark plug(s) is pitted, fouled, or the gap is incorrect. 6. The fuel-tank vent is blocked. 7. There is dirt in the fuel filter. 8. Dirt, water, or stale fuel is in the fuel system. 9. There is incorrect fuel in the fuel tank.	1. Reduce the ground speed. 2. Clean the air-cleaner element. 3. Add oil to the crankcase. 4. Remove the obstruction from the cooling fins and air passages. 5. Install a new, correctly gapped spark plug(s). 6. Contact an Authorized Service Dealer. 7. Replace the fuel filter. 8. Contact an Authorized Service Dealer. 9. Drain the tank and replace the fuel with the proper type.

Problem	Possible Cause	Corrective Action
The machine does not drive.	<ol style="list-style-type: none"> 1. The bypass valves are open. 2. The traction belts are worn, loose, or broken. 3. The traction belts are off the pulleys. 4. The transmission has failed. 	<ol style="list-style-type: none"> 1. Close the tow valves. 2. Contact an Authorized Service Dealer. 3. Contact an Authorized Service Dealer. 4. Contact an Authorized Service Dealer.
The machine vibrates abnormally.	<ol style="list-style-type: none"> 1. The cutting blade(s) is/are bent or unbalanced. 2. The blade mounting bolt is loose. 3. The engine mounting bolts are loose. 4. The engine pulley, idler pulley, or blade pulley is loose. 5. The engine pulley is damaged. 6. The blade spindle is bent. 7. The motor mount is loose or worn. 	<ol style="list-style-type: none"> 1. Install new cutting blade(s). 2. Tighten the blade mounting bolt. 3. Tighten the engine mounting bolts. 4. Tighten the appropriate pulley. 5. Contact an Authorized Service Dealer. 6. Contact an Authorized Service Dealer. 7. Contact an Authorized Service Dealer.
The cutting height is uneven.	<ol style="list-style-type: none"> 1. The blade(s) is not sharp. 2. A cutting blade(s) is/are bent. 3. The mower is not level. 4. An anti-scalp roller (if applicable) is not set correctly. 5. The underside of the mower deck is dirty. 6. The tire pressure is incorrect. 7. A blade spindle is bent. 	<ol style="list-style-type: none"> 1. Sharpen the blade(s). 2. Install a new cutting blade(s). 3. Level the mower from side-to-side and front-to-rear. 4. Adjust the anti-scalp wheel height. 5. Clean the underside of the mower deck. 6. Adjust the tire pressure. 7. Contact an Authorized Service Dealer.
The blades do not rotate.	<ol style="list-style-type: none"> 1. The drive belt is worn, loose or broken. 2. The drive belt is off of the pulley. 3. The power-takeoff (PTO) switch or PTO clutch is faulty. 4. The mower belt is worn, loose, or broken. 	<ol style="list-style-type: none"> 1. Install a new drive belt. 2. Install the drive belt and check the adjusting shafts and belt guides for the correct position. 3. Contact an Authorized Service Dealer. 4. Install a new mower belt.

Schematics

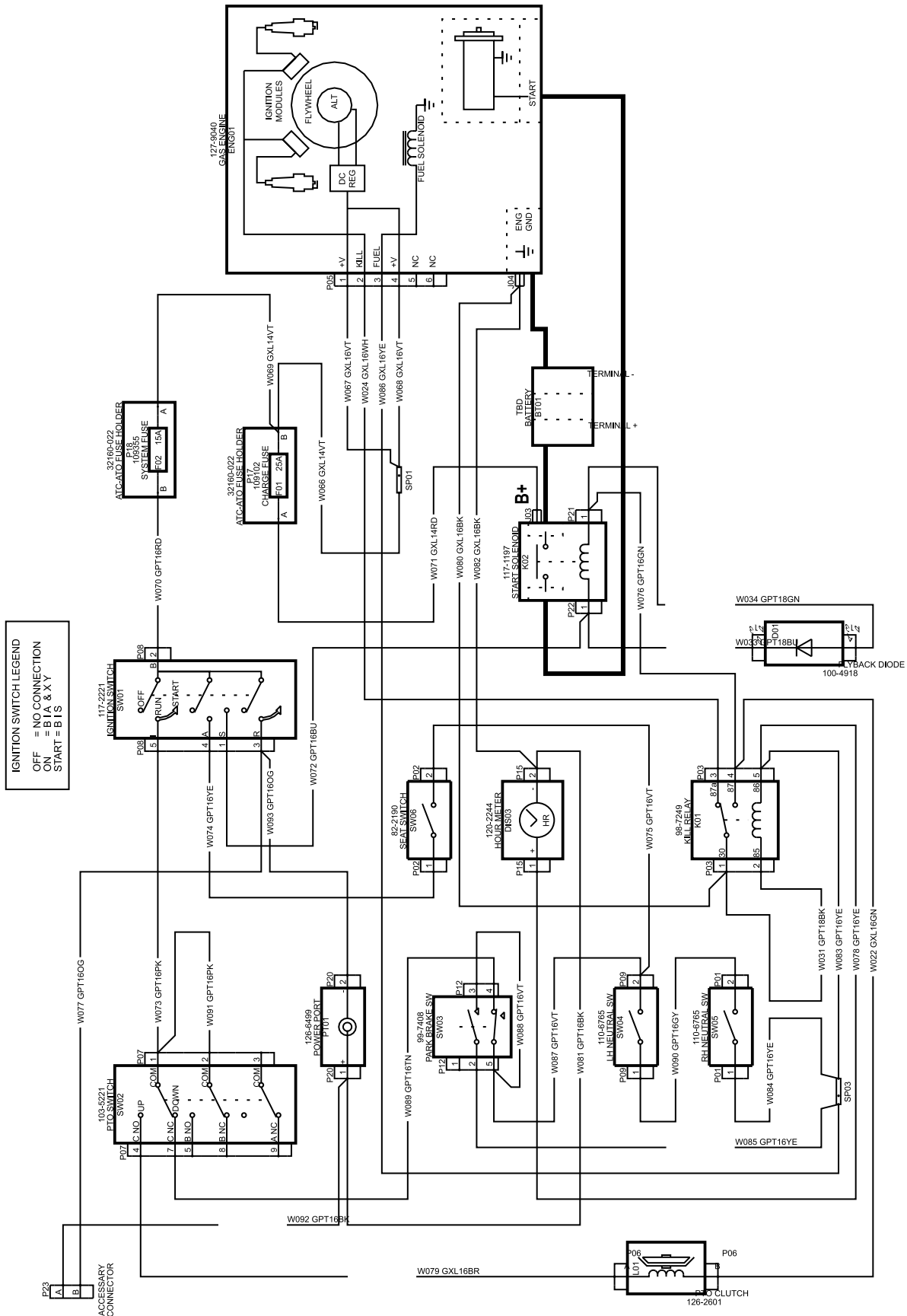

Electrical Diagram (Rev. A)

g203461

Notes:



Count on it.