

Model XFD01,XFD01Z,XFD01CW Parts List

A = Standard Equipment

O = Circuit Diagram

Item#	Part#	Description	Q'ty	Unit	
001	815C17-6	XFD01 NAME PLATE	1		
002	188932-2	HOUSING SET	1	PC. (LXFD01, LXFD01Z)	
002	188931-4	HOUSING SET	1	PC. (LXFD01CW)	
	D10	INC. 19			
003	266429-2	TAPPING SCREW 3X16	9	PC.	
004	126289-3	SPEED CHANGE LEVER ASSEMBLY	1	PC.	
	C10	233438-6	COMPRESSION SPRING 4	2	PC.
005	419250-0	F/R CHANGE LEVER	1	PC.	
006-1	650731-7	SWITCH C3HZ-1A-TLMS	1		
007	620012-3	LED CIRCUIT	1	PC.	
008	643852-2	TERMINAL	1	PC.	
009	251468-5	- FLAT HEAD SCREW M6X22	1	PC.	
010	766008-1	KEYLESS DRILL CHUCK 13	1	PC.	
011	125831-7	GEAR ASSEMBLY	1	PC.	
012	638425-4	YOKE UNIT	1	PC.	
013	619263-3	ARMATURE	1	PC.	
014	638494-5	BRUSH HOLDER COMPLETE	1	PC.	
015	195021-6	CARBON BRUSH CB-440	1	SET	
016	263032-0	RUBBER PIN 4	2	PC.	
017	452205-2	REAR COVER	1	PC. (LXFD01, LXFD01Z)	
017	452202-8	REAR COVER	1	PC. (LXFD01CW)	
018	266429-2	TAPPING SCREW 3X16	2	PC.	
019	188932-2	HOUSING SET	1	PC. (LXFD01, LXFD01Z)	
019	188931-4	HOUSING SET	1	PC. (LXFD01CW)	
	D10	INC. 2			
020	232182-2	LEAF SPRING	1	PC.	
021	689170-4	HEAT SINK	1	PC.	
022	911013-5	PAN HEAD SCREW M3X10	1	PC.	
023	802P77-5	CAUTION LABEL	1		
A01	251314-2	+ SCREW M4X12	1	PC.	
A02	346449-3	HOOK	1	PC.	
A03	784637-8	+ - BIT 2-45	1	PC.	
A04	141856-3	PLASTIC CARRYING CASE COMPLETE	1	PC. (LXFD01, LXFD01CW)	
	C10	162302-3	LATCH	2	PC. (LXFD01, LXFD01CW)
	C20	324207-7	SHAFT	1	PC. (LXFD01, LXFD01CW)
	C30	451749-9	HANDLE	1	PC. (LXFD01, LXFD01CW)
A05	450128-8	BATTERY COVER	1	PC. (LXFD01, LXFD01CW)	
A06	***DC18RC	DC18RC FAST CHARGER	1	PC. (LXFD01, LXFD01CW)	
A07	BL1830	BATTERY BL1830 SET	2	SET (LXFD01)	
A07	BL1815	BATTERY BL1815 SET	2	SET (LXFD01CW)	

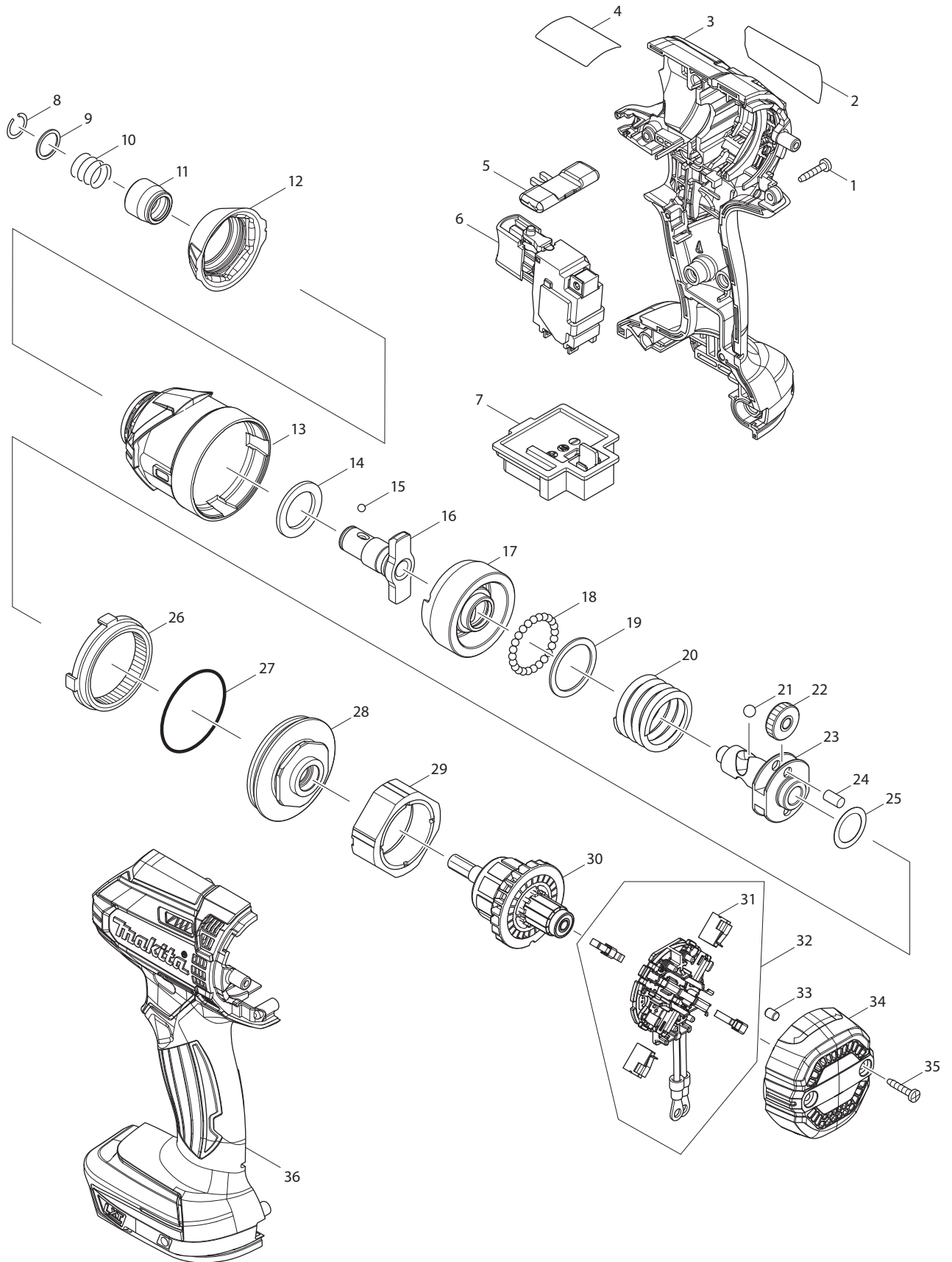

Model XDT11R Parts list

A = Standard Equipment

O = Circuit Diagram

Item#	Part#	Description	Q'ty	Unit
001	266429-2	TAPPING SCREW 3X16	8	PC.
002	851E28-9	XDT11 NAME PLATE	1	
003	183B63-4	HOUSING SET	1	
	C10 263005-3	RUBBER PIN 6	2	PC.
	D10	INC. 36		
004	806W83-4	CAUTION LABEL	1	
005	455053-8	F/R CHANGE LEVER	1	PC.
006	650751-1	SWITCH	1	
	C10 620445-2	LED CIRCUIT	1	
007	643852-2	TERMINAL	1	PC.
008	231951-8	RING SPRING 11	1	PC.
009	267085-1	FLAT WASHER 12	1	PC.
010	233005-7	COMPRESSION SPRING 13	1	PC.
011	326068-1	BIT SLEEVE	1	PC.
012	424738-7	BUMPER	1	
013	143299-5	HAMMER CASE COMPLETE	1	
014	261151-6	NYLON WASHER 19	1	PC.
015	216040-0	STEEL BALL 3.5	2	PC.
016	326563-1	ANVIL M	1	
017	326564-9	HAMMER	1	
018	216040-0	STEEL BALL 3.5	24	PC.
019	267175-0	FLAT WASHER 24	1	PC.
020	234251-5	COMPRESSION SPRING 25	1	PC.
021	216041-8	STEEL BALL 5.6	2	
022	227362-3	SPUR GEAR 22	2	PC.
023	326562-3	SPINDLE	1	
024	256253-1	PIN 5	2	PC.
025	253314-8	THIN WASHER 15	1	PC.
026	227378-8	INTERNAL GEAR 51	1	
027	213507-9	O RING 40	1	PC.
028	143298-7	BEARING BOX COMPLETE	1	
029	638396-5	YOKE UNIT	1	PC.
030	619377-8	ARMATURE	1	
031	CB448	CARBON BRUSH CB-448 (196855-0)	2	
032	632F23-2	BRUSH HOLDER COMPLETE	1	
	D10	INC. 31		
033	263032-0	RUBBER PIN 4	4	PC.
034	456044-2	REAR COVER	1	
035	266429-2	TAPPING SCREW 3X16	2	PC.
036	183B63-4	HOUSING SET	1	
	C10 263005-3	RUBBER PIN 6	2	PC.
	D10	INC. 3		
A01	346449-3	HOOK	1	PC.
A02	266622-8	+ TRUSS HEAD SCREW M4X12	1	PC.
A03	141856-3	PLASTIC CARRYING CASE COMPLETE	1	PC. (XDT11R)
	C10 162302-3	LATCH	2	PC. (XDT11R)
	C20 324207-7	SHAFT	1	PC. (XDT11R)
	C30 451749-9	HANDLE	1	PC. (XDT11R)
A04	450128-8	BATTERY COVER	1	PC. (XDT11R)
A05	***DC18RC	DC18RC FAST CHARGER	1	PC. (XDT11R)
A06	BL1820B	BATTERY BL1820B SET	2	(XDT11R)
D01	652045-0	+PAN HEAD SCREW M3.5X5	2	PC.

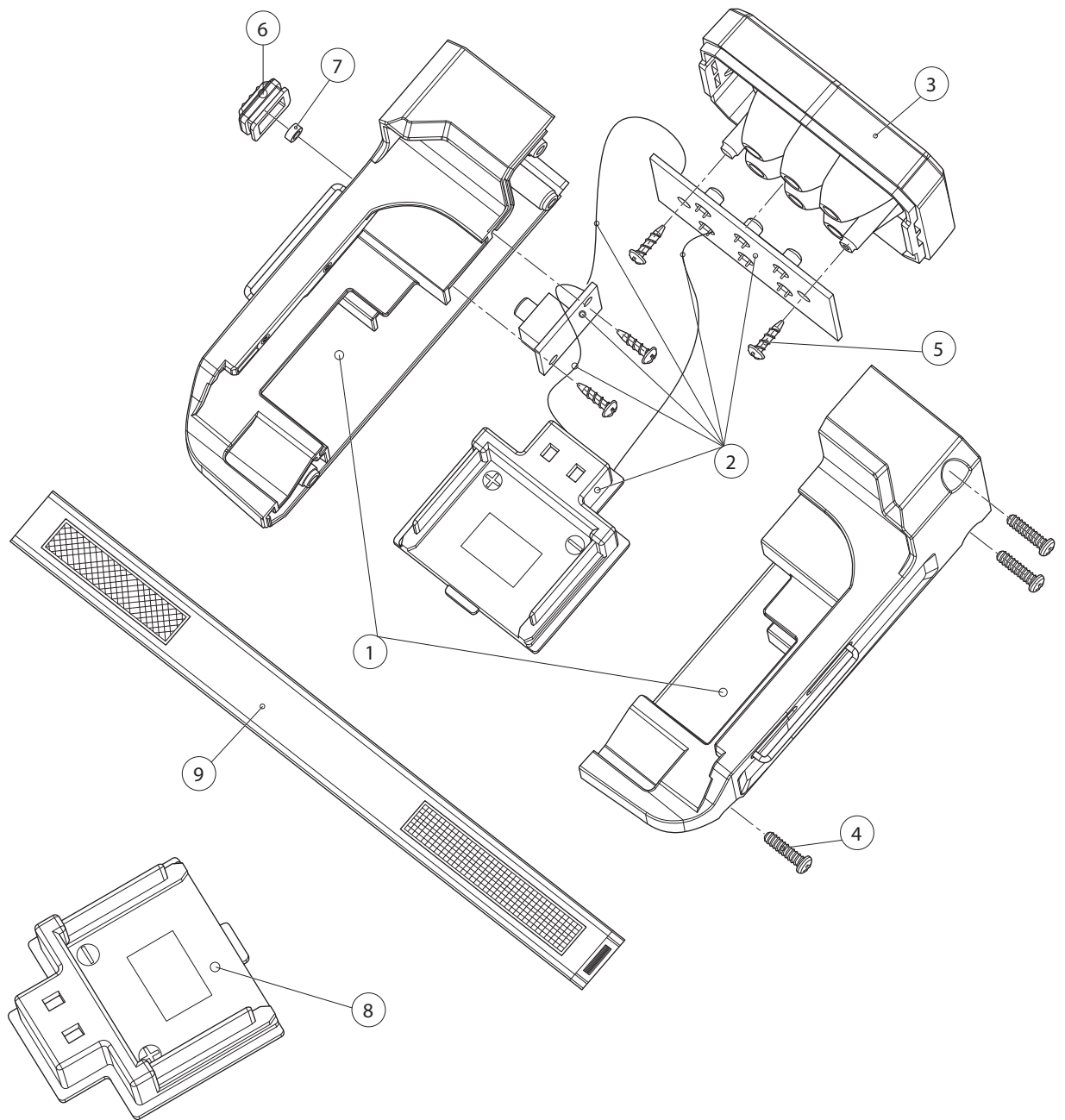

Model DML186W Parts List

A = Standard Equipment

O = Circuit Diagram

Item#	Part#	Description	Q'ty	Unit
001	GM00001186	H.BODY ASSY:W (ROS11869803)	1	PC.
002	GM00001239	LED CIRCUIT ASSY (ROS11869805)	1	PC.
003	GM00001188	LIGHT HEAD ASSY (ROS11869804)	1	PC.
004	GM00001189	SCREW 3X12BB (B0130120712)	3	PC.
005	GM00001190	SCREW 2.6X10PWA (B0126100705)	4	PC.
006	GM00001191	SWITCH COVER (C9010186006)	1	PC.
007	GM00001192	SWITCH COVER RING(C0110186010)	1	PC.
008	GM00001116	BATTERY HOLDER (C2004185006)	1	PC.
009	GM00001193	RUBBER BAND (D1101186100)	1	PC.