



# MAGNUM<sup>®</sup>

## TRUEAIRLESS<sup>™</sup>

Electric Airless Sprayer

### **OWNERS MANUAL**

**X5, X7, ProX17, ProX19, ProX21**  
**3A3208B**

EN



## **WARNING**

### **FIRE AND EXPLOSION HAZARD**

#### **X5/X7 Models:**

- Use only non-flammable or water-based materials, or non-flammable paint thinners. Do not use materials having flash points lower than 100° F (38° C). This includes, but is not limited to, acetone, xylene, toluene, or naphtha. For more information about your material, request Safety Data Sheet (SDS) from the supplier.
- Spraying flammable or combustible materials in a factory or fixed location must comply with NFPA 33 and OSHA 1910.94(c) requirements in the USA and with all similar local regulations in other countries.

***Not approved for use in explosive atmospheres or hazardous locations.  
For portable airless spraying of architectural paints and coatings.***



### **Important Safety Instructions**

Read all warnings and instructions in this manual, related manuals, and on the unit. Be familiar with the controls and the proper usage of the equipment. Save these instructions.

# Before You Spray

## Before You Spray

### Review Warnings for Important Safety Information

Important! Read carefully and practice good safety habits.

### Review Manual & Watch Videos

Scan QR code for Operational Video or go to [magnum.graco.com/magop](http://magnum.graco.com/magop)

### Related Manuals

Gun: 312830 (SG)  
ProXChange™ Pump: 3A3172 (ProX only)



## Models

3000 psi (207 bar, 20.7 MPa) Maximum Working Pressure

	VAC	Model	Stand (Series)	Cart (Series)
 Intertek 110474 Certified to CAN/CSA C22.2 No. 68 Conforms to UL 1450	120 USA	X5	262800 (E) 17K437 (A)	
		X7		262805 (D)
		ProX17	17G177 (A) 17K438 (A)	17G178 (A)
		ProX19	17G179 (A)	17G180 (A) 17K439 (A)
		ProX21	17G181 (A)	17G182 (A)

## Warnings

The following warnings are for the setup, use, grounding, maintenance, and repair of this equipment. The exclamation point symbol alerts you to a general warning and the hazard symbols refer to procedure-specific risks. When these symbols appear in the body of this manual or on warning labels, refer back to these Warnings. Product-specific hazard symbols and warnings not covered in this section may appear throughout the body of this manual where applicable.

### **WARNING**



#### **GROUNDING**

This product must be grounded. In the event of an electrical short circuit, grounding reduces the risk of electric shock by providing an escape wire for the electric current. This product is equipped with a cord having a grounding wire with an appropriate grounding plug. The plug must be plugged into an outlet that is properly installed and grounded in accordance with all local codes and ordinances.

- Improper installation of the grounding plug is able to result in a risk of electric shock.
- When repair or replacement of the cord or plug is required, do not connect the grounding wire to either flat blade terminal.
- The wire with insulation having an outer surface that is green with or without yellow stripes is the grounding wire.
- Check with a qualified electrician or serviceman when the grounding instructions are not completely understood, or when in doubt as to whether the product is properly grounded.
- Do not modify the plug provided; if it does not fit the outlet, have the proper outlet installed by a qualified electrician.
- This product is for use on a nominal 120V circuit and has a grounding plug similar to the plugs illustrated below.

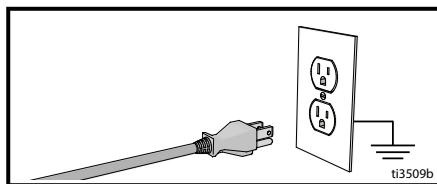

- Only connect the product to an outlet having the same configuration as the plug.
- Do not use an adapter with this product.

#### **Extension Cords:**

- Use only a 3-wire extension cord that has a grounding plug and a grounding receptacle that accepts the plug on the product.
- Make sure your extension cord is not damaged. If an extension cord is necessary use 12 AWG (2.5mm<sup>2</sup>) minimum to carry the current that the product draws.
- An undersized cord results in a drop in line voltage and loss of power and overheating.

Conductor Size		Length
AWG (American Wire Gauge)	Metric	Maximum
16	1.5 mm <sup>2</sup>	25 ft. (8 m)
12	2.5 mm <sup>2</sup>	50 ft. (15 m)

**WARNING**
**FIRE AND EXPLOSION HAZARD**

Flammable fumes, such as solvent and paint fumes, in work area can ignite or explode. To help prevent fire and explosion:

**X5/X7 Models:**

- Do not spray or clean with materials having flash points lower than 100°F (38° C). Use only non-flammable or water-based materials, or non-flammable paint thinners. For complete information about your material, request the Safety Data Sheet (SDS) from the material distributor or retailer.
- Do not spray combustible materials near an open flame or sources of ignition such as cigarettes, motors, and electrical equipment.
- Do not spray combustible liquids in a confined area.

**ProX Models:**

- Do not spray flammable or combustible materials near an open flame or sources of ignition such as cigarettes, motors, and electrical equipment.
- Do not spray flammable or combustible liquids in a confined area.

**All Models:**

- Paint or solvent flowing through the equipment is able to result in static electricity. Static electricity creates a risk of fire or explosion in the presence of paint or solvent fumes. All parts of the spray system, including the pump, hose assembly, spray gun, and objects in and around the spray area shall be properly grounded to protect against static discharge and sparks. Use Graco conductive or grounded high-pressure airless paint sprayer hoses.
- Verify that all containers and collection systems are grounded to prevent static discharge. Do not use pail liners unless they are anti-static or conductive.
- Connect to a grounded outlet and use grounded extensions cords. Do not use a 3-to-2 adapter.
- Do not use a paint or a solvent containing halogenated hydrocarbons.
- Keep spray area well-ventilated. Keep a good supply of fresh air moving through the area.
- Sprayer generates sparks. Keep pump assembly in a well ventilated area a least 20 feet (6.1 m) from the spray area when spraying, flushing, cleaning, or servicing. Do not spray pump assembly.
- Do not smoke in the spray area or spray where sparks or flame is present.
- Do not operate light switches, engines, or similar spark producing products in the spray area.
- Keep area clean and free of paint or solvent containers, rags, and other flammable materials.
- Know the contents of the paints and solvents being sprayed. Read all Safety Data Sheets (SDSs) and container labels provided with the paints and solvents. Follow the paint and solvents manufacturer's safety instructions.
- Fire extinguisher equipment shall be present and working.

## **WARNING**



### **SKIN INJECTION HAZARD**

High-pressure spray is able to inject toxins into the body and cause serious bodily injury. In the event that injection occurs, **get immediate surgical treatment.**

- Do not aim the gun at, or spray any person or animal.
- Keep hands and other body parts away from the discharge. For example, do not try to stop leaks with any part of the body.
- Always use the nozzle tip guard. Do not spray without nozzle tip guard in place.
- Use Graco nozzle tips.
- Use caution when cleaning and changing nozzle tips. In the case where the nozzle tip clogs while spraying, follow the **Pressure Relief Procedure** for turning off the unit and relieving the pressure before removing the nozzle tip to clean.
- Equipment maintains pressure after power is shut off. Do not leave the equipment energized or under pressure while unattended. Follow the **Pressure Relief Procedure** when the equipment is unattended or not in use, and before servicing, cleaning, or removing parts.
- Check hoses and parts for signs of damage. Replace any damaged hoses or parts.
- This system is capable of producing 3000 psi. Use Graco replacement parts or accessories that are rated a minimum of 3000 psi.
- Always engage the trigger lock when not spraying. Verify the trigger lock is functioning properly.
- Verify that all connections are secure before operating the unit.
- Know how to stop the unit and bleed pressure quickly. Be thoroughly familiar with the controls.



### **EQUIPMENT MISUSE HAZARD**

Misuse can cause death or serious injury.

- Always wear appropriate gloves, eye protection, and a respirator or mask when painting.
- Do not operate or spray near children. Keep children away from equipment at all times.
- Do not overreach or stand on an unstable support. Keep effective footing and balance at all times.
- Stay alert and watch what you are doing.
- Do not operate the unit when fatigued or under the influence of drugs or alcohol.
- Do not kink or over-bend the hose.
- Do not expose the hose to temperatures or to pressures in excess of those specified by Graco.
- Do not use the hose as a strength member to pull or lift the equipment.
- Do not spray with a hose shorter than 25 feet.
- Do not alter or modify equipment. Alterations or modifications may void agency approvals and create safety hazards.
- Make sure all equipment is rated and approved for the environment in which you are using it.



### **ELECTRIC SHOCK HAZARD**

This equipment must be grounded. Improper grounding, setup, or usage of the system can cause electric shock.

- Turn off and disconnect power cord before servicing equipment.
- Connect only to grounded electrical outlets.
- Use only 3-wire extension cords.
- Ensure ground prongs are intact on power and extension cords.
- Do not expose to rain. Store indoors.



## **WARNING**



### **PRESSURIZED ALUMINUM PARTS HAZARD**

Use of fluids that are incompatible with aluminum in pressurized equipment can cause serious chemical reaction and equipment rupture. Failure to follow this warning can result in death, serious injury, or property damage.

- Do not use 1,1,1-trichloroethane, methylene chloride, other halogenated hydrocarbon solvents or fluids containing such solvents.
- Do not use chlorine bleach.
- Many other fluids may contain chemicals that can react with aluminum. Contact your material supplier for compatibility.



### **MOVING PARTS HAZARD**

Moving parts can pinch, cut, or amputate fingers and other body parts.

- Keep clear of moving parts.
- Do not operate equipment with protective guards or covers removed.
- Pressurized equipment can start without warning. Before checking, moving, or servicing equipment, follow the **Pressure Relief Procedure** and disconnect all power sources.



### **TOXIC FLUID OR FUMES HAZARD**

Toxic fluids or fumes can cause serious injury or death if splashed in the eyes or on skin, inhaled, or swallowed.

- Read MSDSs to know the specific hazards of the fluids you are using.
- Store hazardous fluid in approved containers, and dispose of it according to applicable guidelines.



### **PERSONAL PROTECTIVE EQUIPMENT**

Wear appropriate protective equipment when in the work area to help prevent serious injury, including eye injury, hearing loss, inhalation of toxic fumes, and burns. This protective equipment includes but is not limited to:



- Protective eyewear, and hearing protection.
- Respirators, protective clothing, and gloves as recommended by the fluid and solvent manufacturer.

### **CALIFORNIA PROPOSITION 65**

This product contains a chemical known to the State of California to cause cancer, birth defects or other reproductive harm. Wash hands after handling.

# ProX17: 17G178, ProX19: 17G180, 17K439

## ProX17: 17G178, ProX19: 17G180, 17K439 Cart Sprayer Parts

Ref.	Torque
	30-35 in-lb (3.5-4.0 N•m)
	110-120 in-lb (12-14 N•m)
	45-55 in-lb (5-6 N•m)

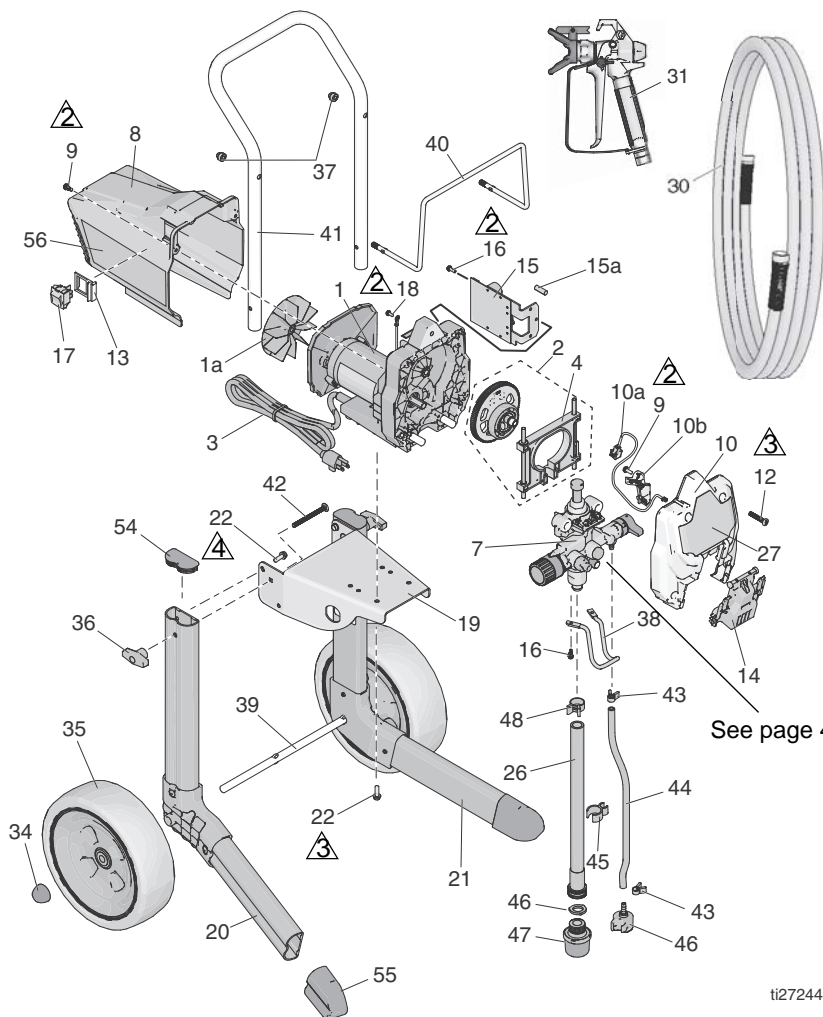

See page 48.

ti27244a

# ProX17: 17G178, ProX19: 17G180, 17K439

## 17G178, 17G180, 17K439 Cart Sprayer Parts List

Ref. Part	Description	Qty.	Ref. Part	Description	Qty.	
1	MOTOR, 120V		34	112612	CAP, hub	2
	17K285 ProX17	1	35		WHEEL <i>includes 34</i>	
	17F756 ProX19	1		24Y324	ProX17	2
1a	287770 FAN	1		17K546	ProX19	2
2	17J863 KIT, gear and yoke	1	36	115480	KNOB, T-handle	2
3	17J173 CORD, power	1	37	120689	NUT, hex, acorn, 5/16-18	2
4	17J864 KIT, yoke	1	38	15J790	HOOK, pail	1
7	17J874 KIT, pump complete	1	39	16W362	AXLE, cart	1
8	17J865 SHIELD, motor, blue <i>includes 9 and labels</i>	1	40	16H350	RACK, hose	1
9	118444 SCREW, mach, hw h d 10-24 x 0.5 in.	3	41		HANDLE, cart	
10	17J866 COVER, front <i>includes 9, 10a, 10b, 12, 14</i>	1		16H354	ProX17	1
10a	128551 CABLE, jumper, PC	1		16H353	ProX19	1
10b	17F262 COVER, wire	1	42	120788	SCREW, carriage	2
12	115478 SCREW, mach, Torx, pan hd	1	43	115489	CLAMP, drain tube	1
13	15J803 SWITCH, bracket	1	44	195108	TUBE, drain	1
14	17F233 COVER, pump, locking	1	45	195400	CLIP, spring	1
15	17J867 KIT, control board 120V <i>includes 15a, 16</i>	1	46	244035	DEFLECTOR, barbed	1
15a	119276 FUSE, 12.5A slow blow	1	47	288716	STRAINER, inlet	1
16	117501 SCREW, plastite	1	48	116295	CLAMP, tube	1
17	24Y329 KIT, switch, repair <i>includes 13</i>	1	49	115099	WASHER, hose	1
18	115498 SCREW, mach, slot, hex whd	1	54	15J699	CAP, tube	2
19	17G541 PLATE, motor, mount	1	55		CAP, tube	
20	262014 ProX17	1		15J695	ProX17	2
	17K185 ProX19	1		16W505	ProX19, right	1
21	262012 ProX17	1		16W517	ProX19, left	1
	17K186 ProX19	1	56▲	17J027	LABEL, warning	1
22	260212 SCREW, hwh, thread forming	8	57▲	222385	CARD, medical alert (not shown)	1
26	24V073 TUBE, suction, assembly	1	60	3A3526	GUIDE, Magnum quick guide, English (not shown)	1
27	17J031 ProX17	1	60a	3A3528	GUIDE, Magnum quick guide, Spanish (not shown)	1
	17J033 ProX19	1	61	115648	VALVE, power flush (not shown)	1
30	247340 HOSE, cpd, 1/4 in. x 50 ft	1	62	244168	FLUID, pump armor, 8 oz (not shown)	1
31	243012 GUN, spray, SG3 Models 17G178, 17G180	1	64	17K631	TAG, hang, tip (not shown)	1
	246506 Models 17K439	1		17J873	KIT, conversion, lacquer, cart (sold separate)	

▲ Replacement Danger and Warning labels, tags, and cards are available at no cost.