

Radon Mitigation Fan Kit: RDN04

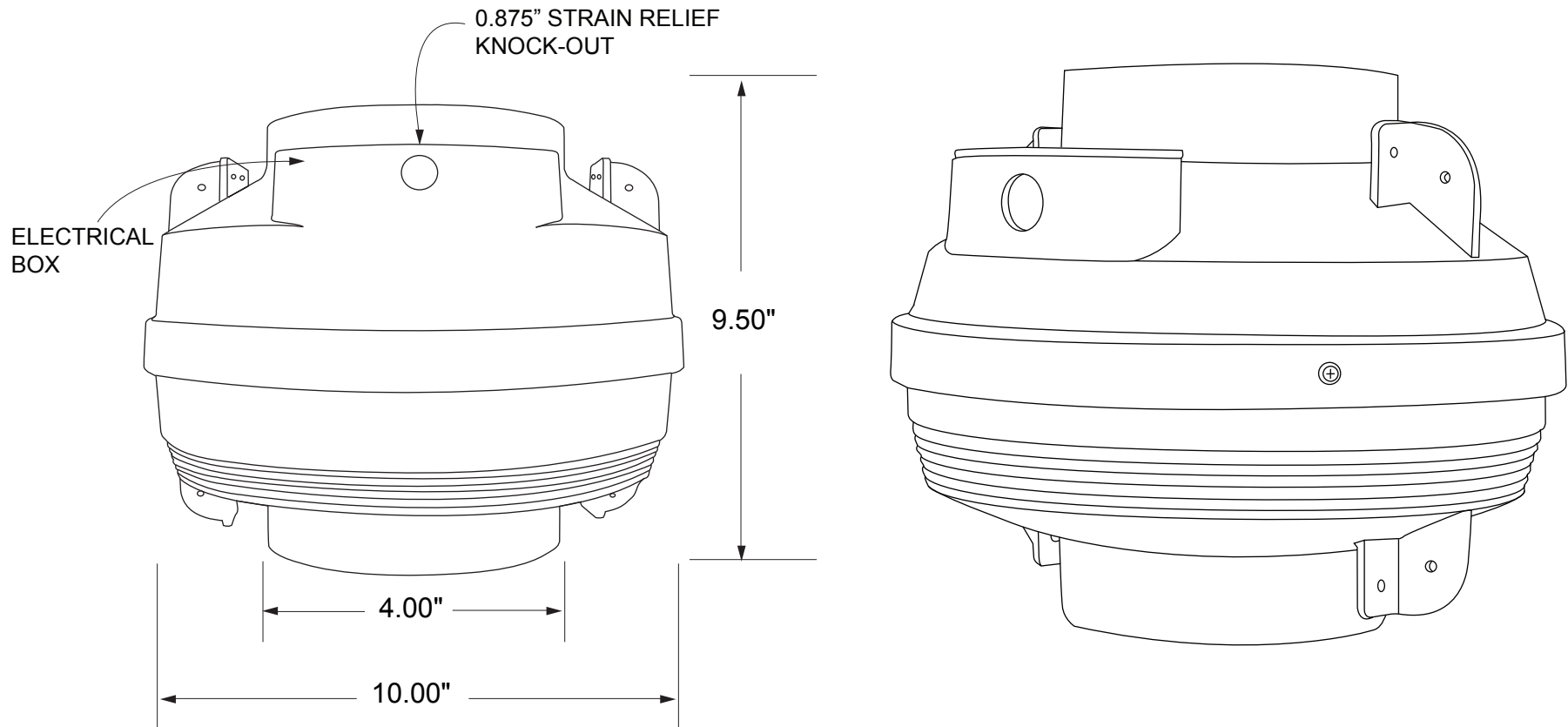

N.T.S.



4" Centrax[®] In-Line Centrifugal Fan[™]

Model: TF104(-W)

Mounting Hardware:

- (4) #8 x 1" Self tapping screws
- (4) #6 X 1/2" Machine screws
- (4) Hex nuts, (4) #6 Lock washers
- (4) Rubber washers
- (2) Fan mounting brackets, (2) Cable ties
- (6) #6 Screws for securing duct connection

- Output/Input Diameter: 4" (po) • Unit weight: 5.45 lbs. • CFM: 200 • Amps: 0.65
- Watts: 77 • Volts: 120 • Hz: 60 • ETL[®] Listed • Class F external rotor motor
- Thermally protected auto reset • Ball bearing balanced ABS backward inclined impeller
- 5 year limited warranty

SUNCOURT INC.
P.O. Box 40
Durant, IA 52747-0040
1.800.999.FANS (3267)
www.suncourt.com

TF104-SS-0716

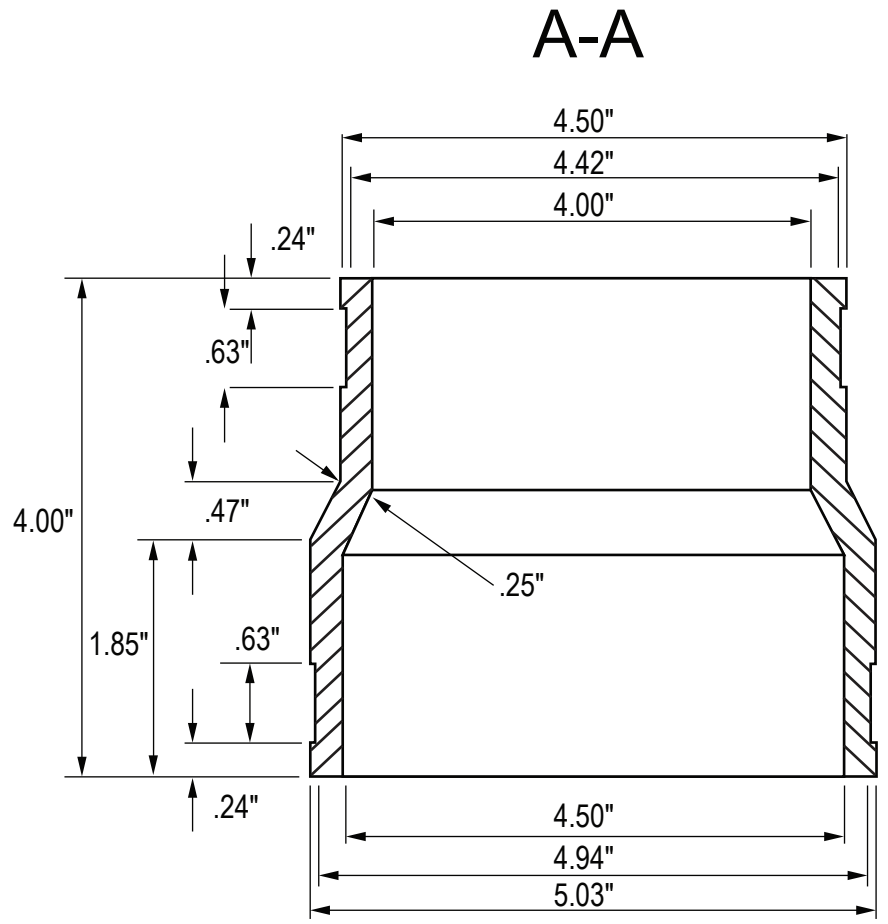
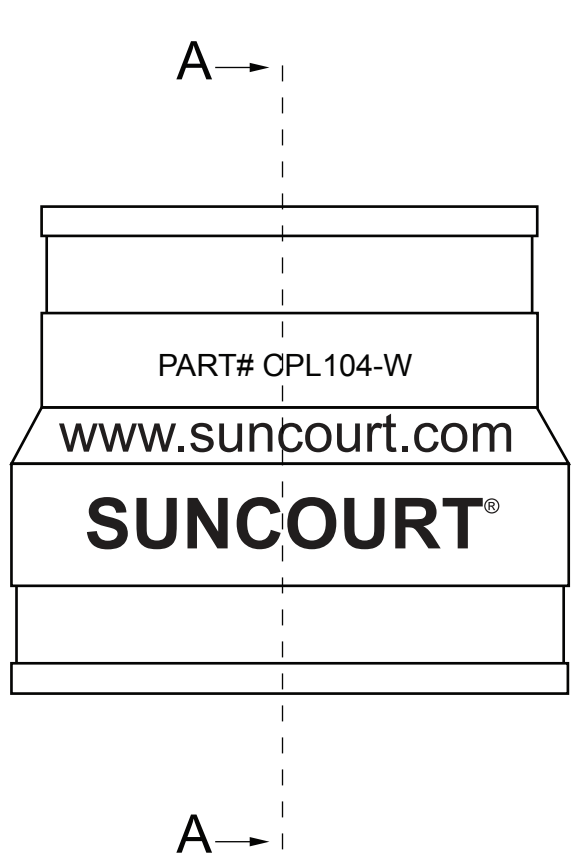

N.T.S.



Suncourt® Rubber Couplers

MODEL CPL104-W

4" to 4" white couplers available in the Suncourt Radon Mitigation In-Line Fan Kit or sold separately in a (2-pack).

DIAMETER: SIZED TO CONNECT SUNCOURT TF104(-W) TO 4" SCHEDULE C PVC
 UNIT WEIGHT: 0.75 LBS
 ONE YEAR LIMITED WARRANTY

SUNCOURT INC.
 P.O. Box 40
 Durant, IA 52747-0040
 1.800.999.FANS (3267)
 www.suncourt.com