

Instruction Manual - Battery-operated Motion Sensing LED Twin Spot Light

LB-1403-WH
LB-1403-BZ

LED 4W

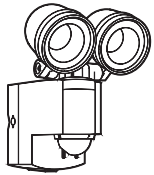
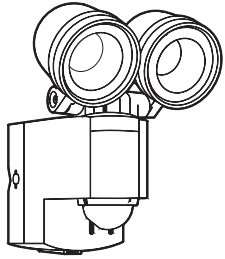

01 x 1



02 x 2



03 x 2

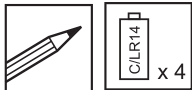

Installation

- Mounting with screws

1. Remove mounting plate.

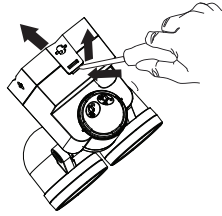

2. Remove rubber plugs

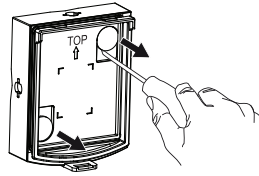

3. Mark holes for mounting with screws.

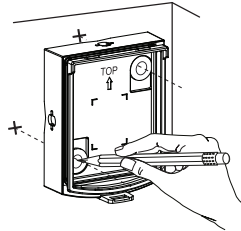
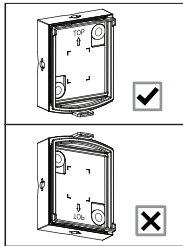

4. Attach the back cover.

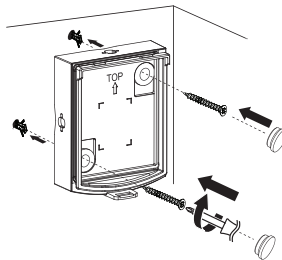

5. Install 4 x "C" batteries.

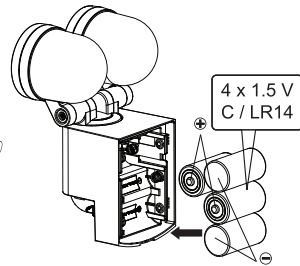

6. Attach the device to the back cover.

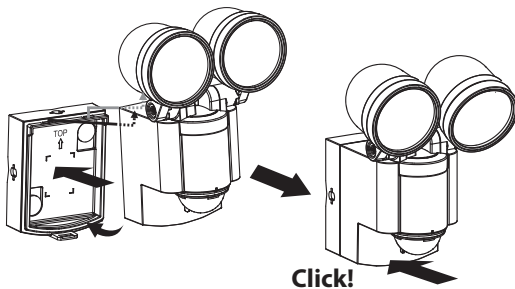

Click!

LED Floodlight adjustment

Adjust the LED floodlight to the desired position.

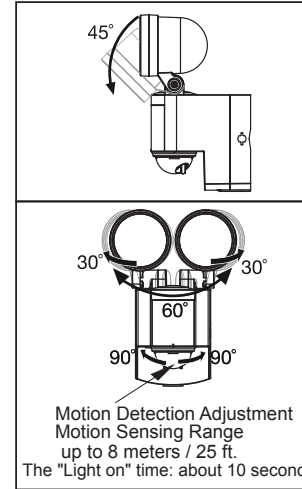
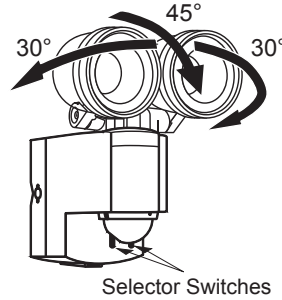

Control Settings

Operation selector switch

Symbols



- OFF
- Motion Detector Mode (LED is switched on when movement is detected)
- Alert mode (LED flashes when movement is detected)

Light level Adjustment

Symbols



- Works only at Night
- Works day and night in any light setting

Battery Caution & Disposal Information:

1. Do not mix old and new batteries.
2. Do not mix Alkaline, Standard (Carbon-Zinc) or Rechargeable (Nickel Cadmium) or (Nickel Metal Hydride) batteries.
3. Do not dispose of batteries in fire.
4. Batteries should be recycled or disposed of as per state and local guidelines.

Customer service number:

For problems or questions, please call us at **1-800-296-1869**

Please retain this instruction manual for future reference

IQ America One Year Warranty

This is a "Limited Warranty" which gives you specific legal rights. You may also have other rights which vary from state to state and province to province.

For a period of one year from the date of purchase, any malfunction caused by factory defective parts or workmanship will be corrected at no charge to you. To obtain a refund or a replacement, return the product to the place of purchase.

NOT COVERED: Repair service, adjustment and calibration due to misuse, abuse or negligence. Unauthorized service or modification of the product or of any furnished component will void this warranty. This warranty does not include reimbursement for inconvenience, installation, setup time, loss of use or unauthorized service.

This warranty covers only IQ America products and is not extended to other equipment and components that a customer uses in conjunction with our products.

This warranty is expressly in lieu of all other warranties, express or implied, including any warranty, representation or condition of merchant ability of that the products are fit for any particular purpose or use, and specifically in lieu of all special, indirect or incidental or consequential damages.

Repair or replacement shall be the sole remedy of the customer and there shall be no liability on the part of IQ America for any special, indirect, incidental or consequential damages, including but not limited to any loss of business or profit, whether or not foreseeable. Some states or provinces do not allow the exclusion or limitation of incidental or consequential damages, so the above limitation or exclusion may not apply to you. Retain receipt for warranty claims.

Made in China