



# MAVERICK BARREL GRILL

## OWNER'S MANUAL

MODEL# GR1031-014985



**Tools required for assembly (Not Included): Pliers, Philips & Flathead Screwdrivers, Adjustable Wrench.**

- This instruction manual contains important information necessary for the proper assembly and safe use of the appliance.
- Read and follow all warnings and instructions before assembling and using the appliance.
- Follow all warnings and instructions when using the appliance.
- Keep this manual for future reference.



## WARNING



**OUTDOOR USE ONLY.**

**Never use grill indoors. Carbon Monoxide poisoning can lead to death.**



# WARNING



- Only use this grill on a hard, level, non-combustible, stable surface (concrete, ground, etc.) capable of supporting the weight of the grill. Never use on wooden or other surfaces that could burn.
- DO NOT attempt to remove charcoal ash tray while coals are hot.
- When grill is in use, keep clearance of 36+between the hot grill and any combustible materials, such as bushes, trees, wooden decks, wooden fences, buildings, etc. Do not place hot grill under roof overhang or in any other enclosed area.
- For outdoor use only. Do not operate grill indoors or in an enclosed area because of carbon monoxide poisoning that can lead to death.
- For household use only. Do not use this grill for other than its intended purpose.
- We recommend the use of a Charcoal Chimney starter to avoid the dangers associated with charcoal lighting fluid. If you choose to use charcoal lighting fluid, only use lighting fluid approved for lighting charcoal. Carefully read manufacturer's warnings and instructions on the charcoal lighting fluid and charcoal prior to the use of their product. Store charcoal lighting fluid safely away from grill.
- When using charcoal lighting fluid, allow charcoal to burn with grill lid and doors open until covered with a light ash (approximately 20 minutes). This will allow charcoal lighting fluid to burn off. Failure to do this could trap fumes from charcoal lighting fluid inside the grill and may result in a flash fire or explosion when lid is opened.
- Do not use gasoline, kerosene or alcohol for lighting charcoal. Use of any of these or similar products could cause an explosion possibly leading to severe bodily injury.
- Never add charcoal lighting fluid to hot or even warm coals as flashback may occur causing severe burns.
- Place grill in an area where children and pets cannot come into contact with unit. Close supervision is necessary when grill is in use.
- Do not leave grill unattended when in use.
- Do not store or use grill near gasoline or other flammable liquids, gases or where flammable vapors may be present.
- Do not store lighter fluid or other flammable liquids or materials under the grill.
- Use only a high grade plain charcoal or charcoal / wood mixture.
- When adding charcoal and / or wood, use extreme caution and follow instructions in %Adding Charcoal / Wood During Cooking+section of this manual.
- Grill is hot when in use. To avoid burns:
  - DO NOT attempt to move the grill.
  - Wear protective gloves or oven mitts.
  - DO NOT touch any hot grill surfaces.
  - DO NOT wear loose clothing or allow hair to come in contact with grill.



# WARNING



- When grilling, grease from meat may drip into the charcoal and cause a grease fire. If this should happen close lid to suffocate the flame. Do not use water to extinguish grease fires.
- Use caution when opening the lid. Keep hands, face and body a safe distance away. Flash flare-ups may occur when air comes into contact with fire or hot coals.
- Never place more than 5 pounds (2.3 kg) on side table. Do not lean on the side table. Always ensure side table is securely fastened.
- Do not allow charcoal and/or wood to rest on the walls of grill. Doing so will greatly reduce the life of the metal and finish of your grill.
- Use caution during assembly and while operating your grill to avoid scrapes or cuts from sharp edges of metal parts. Use caution when reaching into or under grill.
- In windy weather, place grill in an outdoor area that is protected from the wind.
- When opening lid, be sure lid is fully opened and secure to prevent lid from closing unexpectedly.
- Close lid to suffocate flames.
- Never leave coals and ashes in grill unattended. Before grill can be left unattended, remaining coals and ashes must be removed from grill. Use caution to protect yourself and property. Carefully place remaining coals and ashes in a non-combustible metal container and saturate completely with water. Allow coals and water to remain in metal container 24 hours prior to disposal.
- Extinguished coals and ashes should be placed a safe distance from all structures and combustible materials.
- With a garden hose completely wet the surface beneath and around grill to extinguish any ashes, coals or embers which may have fallen during the cooking or cleaning process.
- After each use, clean the grill thoroughly and apply a light coat of vegetable oil to prevent rusting. Cover the grill to protect it from excessive rusting.
- Use caution when lifting or moving grill to prevent strains and back injuries.
- We advise that a fire extinguisher be on hand. Refer to your local authority to determine proper size and type of fire extinguisher.
- Store the grill out of reach of children and in a dry location when not in use.
- Do not attempt to service grill other than normal maintenance as explained in %After-Use Safety+and %Proper Care & Maintenance+sections of this manual.
- Properly dispose of all packaging material
- Use caution and common sense when operating your grill
- Failure to adhere to safety warning and guidelines in this manual could result in bodily injury or property damage.
- Save this manual for future reference.

# ASSEMBLY INSTRUCTIONS

## THANK YOU FOR PURCHASING THIS GRILL

Read all safety warnings & assembly instructions carefully before assembling or operating your grill.

For assembly assistance, missing or damaged parts, please email at [customerservice@rankam.com](mailto:customerservice@rankam.com) or call Rankam customer service at 1-888-837-1380, Monday thru Friday 8AM to 5PM Pacific Standard Time.

(Proof of purchase will be required)

Inspect contents of the box to ensure all parts are included and undamaged.

The following tools are required for assembly and are not included:

- Pliers
- Philips & Flathead Screwdrivers
- Adjustable Wrench



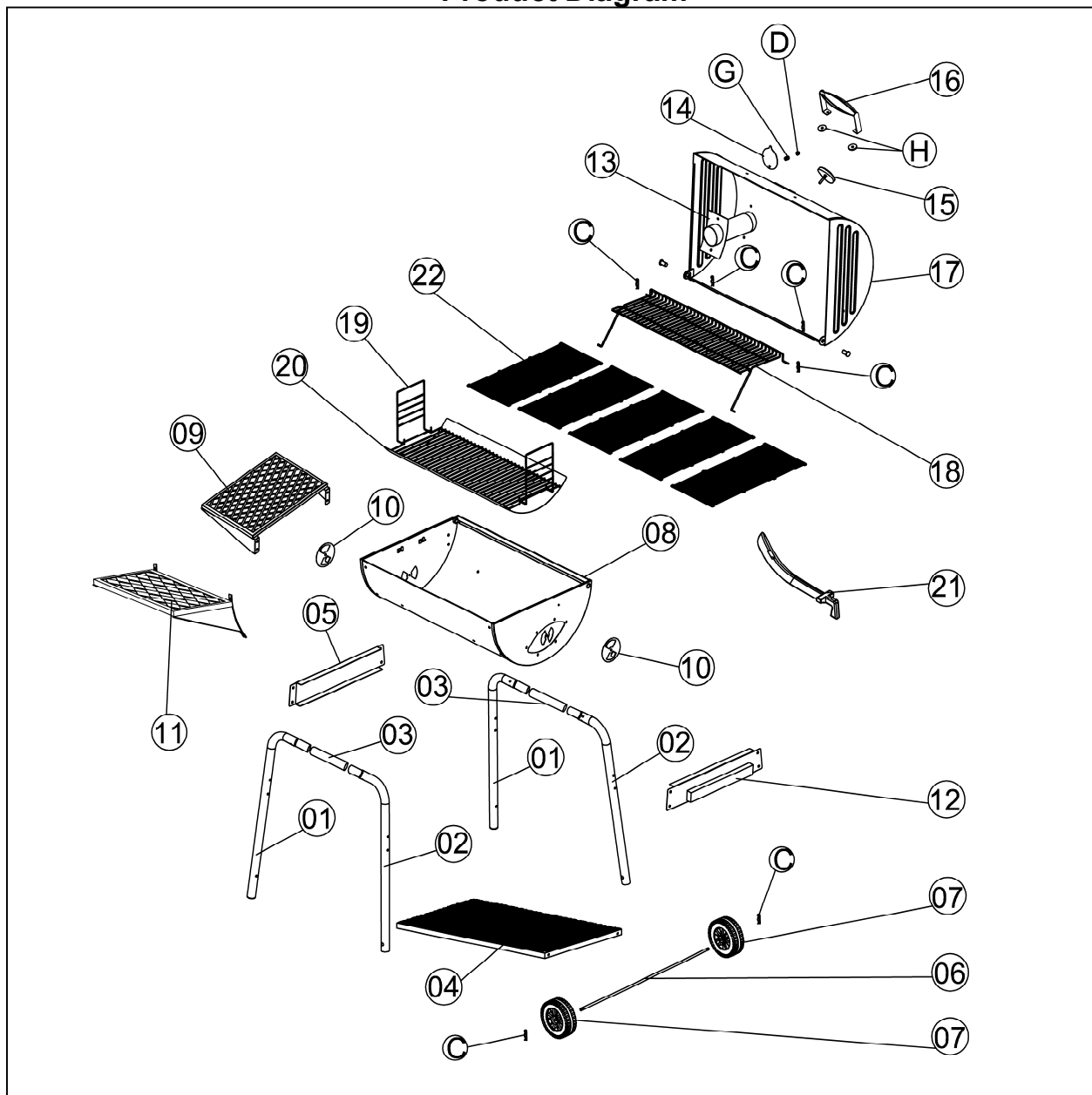









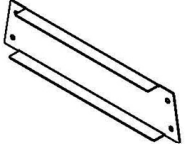

### Product Diagram

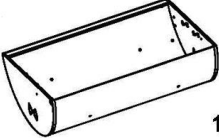

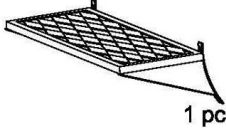
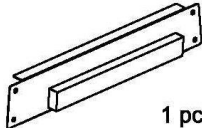
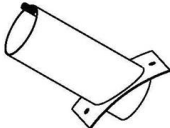

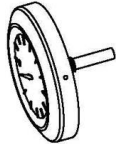
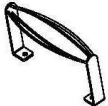

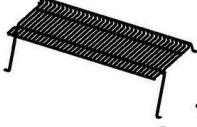
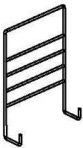
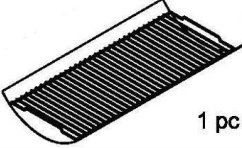
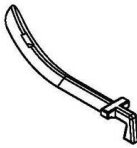

# STOP! DO NOT RETURN TO RETAILER.

For assembly assistance, missing or damaged parts, please contact Rankam customer service at [customerservice@rankam.com](mailto:customerservice@rankam.com) or call 1-888-837-1380, Monday thru Friday 8AM to 5PM Pacific Standard Time.

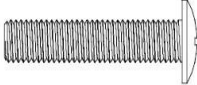
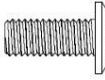
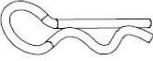
## Component List

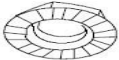
1. Long leg  2 pcs	2. Short leg  2 pcs	3. Connecting tube  2 pcs
4. Bottom rack  1 pc	5. (L) Fixing plate  1 pc	6. Axle  1 pc
7. Wheel  2 pcs	8. Grill body  1 pc	9. Side Table  1 pc
10. Air Vent  2 pcs	11. Front shelf  1 pc	12. (R) Fixing plate  1 pc
13. Smoke stack  1 pc	14. Stack cover  1 pc	15. Thermometer  1 pc
16. Handle  1 pc	17. Lid  1 pc	18. Warming rack  1 pc
19. Ash pan holder  2 pcs	20. Ash pan  1 pc	21. Lifter  1 pc
22. Cooking grate  5 pcs		

## Hardware List

A	Bolt M6x50		12 pcs
B	Bolt M6x15		18 pcs
C	Cotter Pin		6 pcs
D	Cap Nut M8		1 pc
E	Lock Nut M6		4 pcs
F	Flange Nut M6		22 pcs
G	Spring		1 pc
H	Insulating Washer		2 pcs
I	Hinge Pin		2 pcs

## ASSEMBLY PROCEDURES

**Symbol:** The following symbols will be shown in each procedure for indication of tightening the bolt and nut if necessary.



**Hand Tighten only at this time**

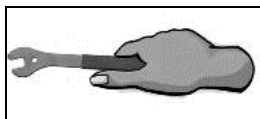

**Tighten with tools at this time**

**Some steps may require the assistance of another adult.**

**STEP 1:**

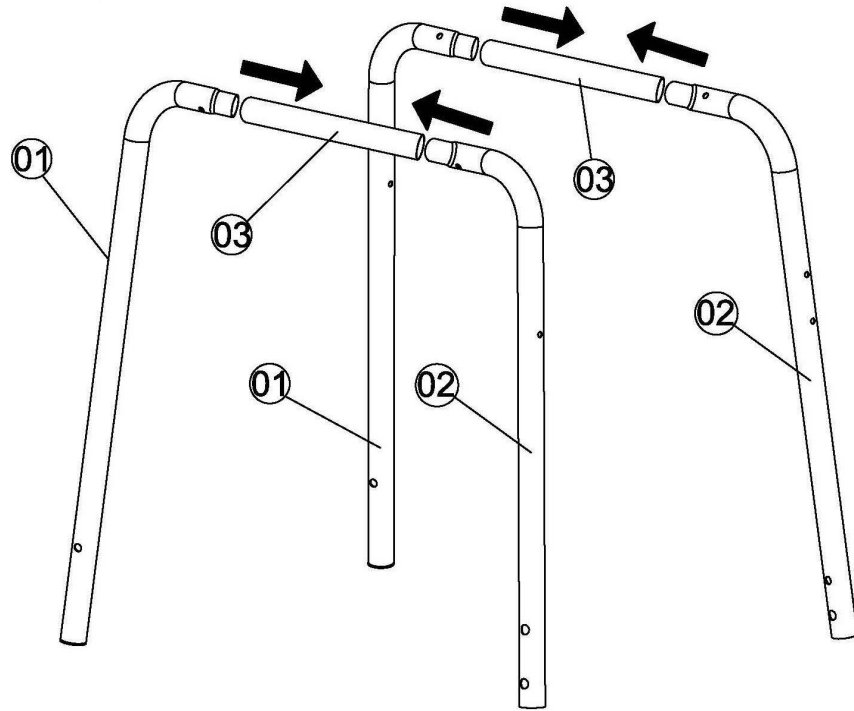

**STEP 2:**

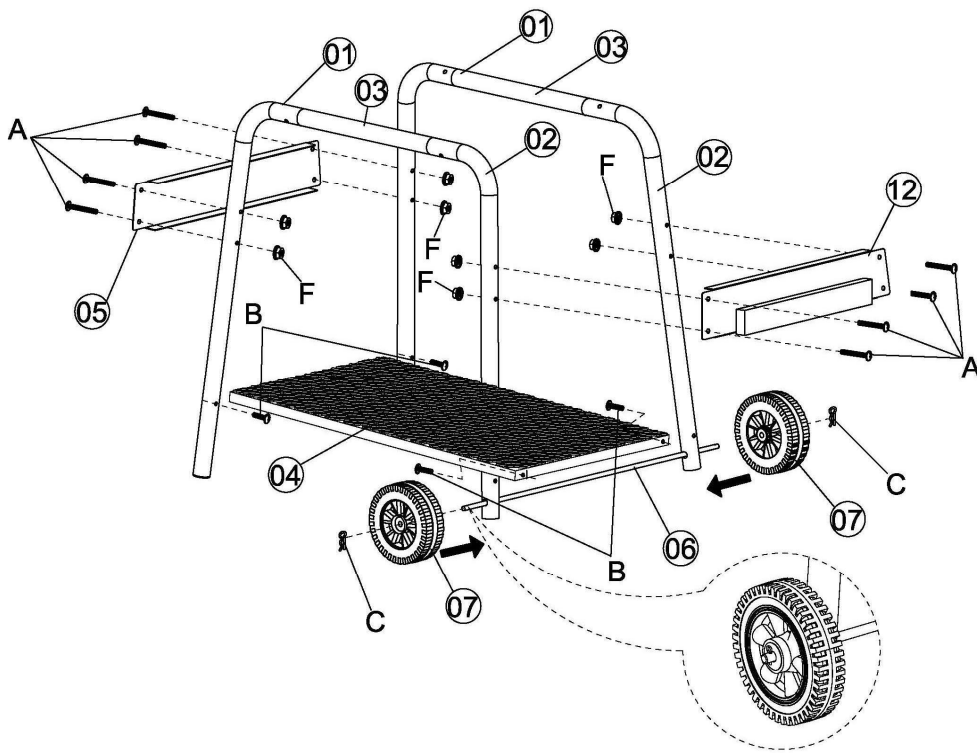

**STEP 3:**

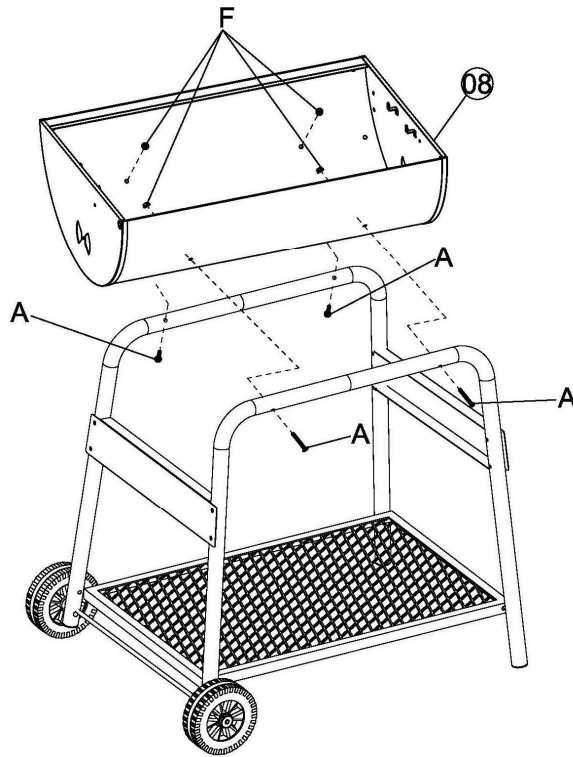

**STEP 4:**

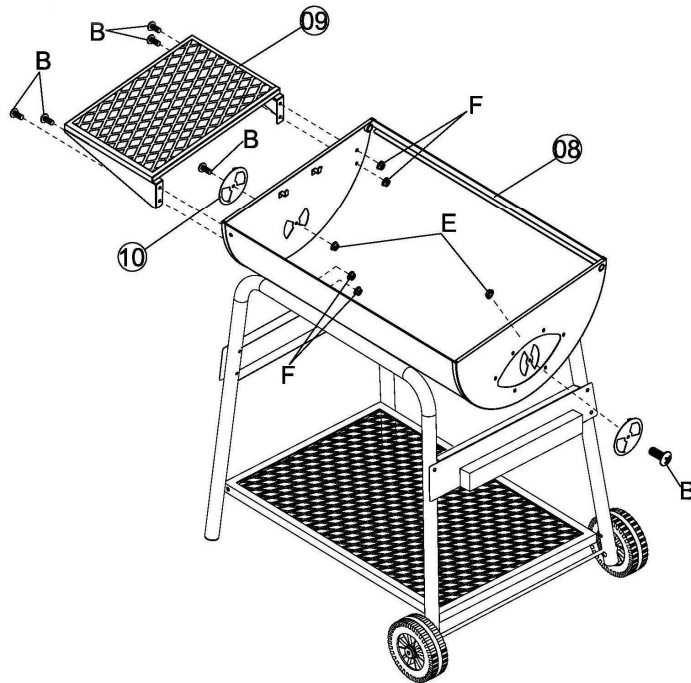



**STEP 5:**

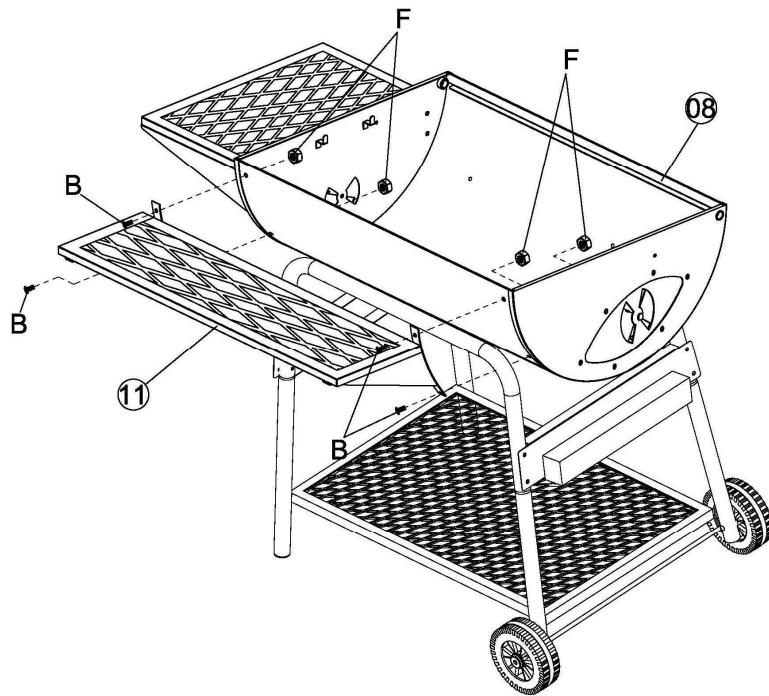

**STEP 6:**

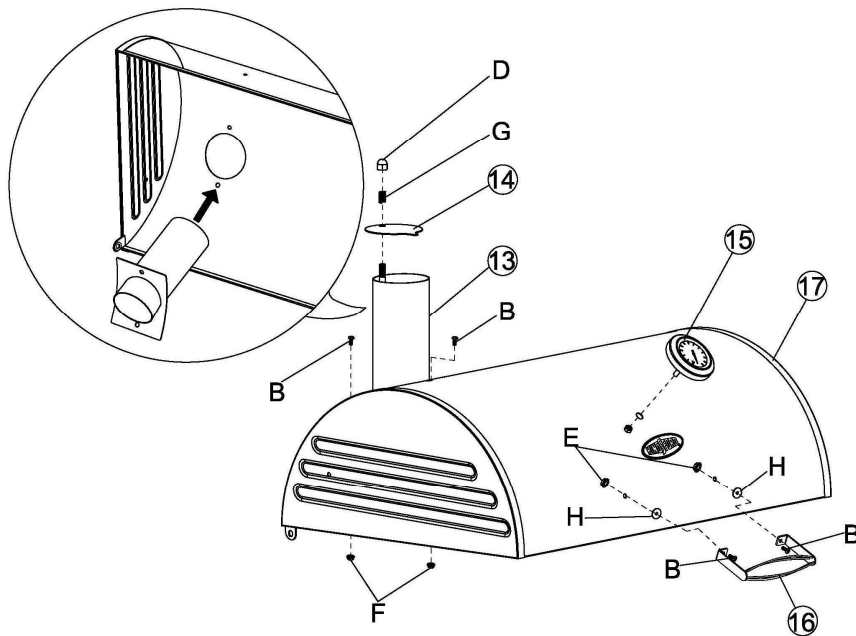

**STEP 7:**

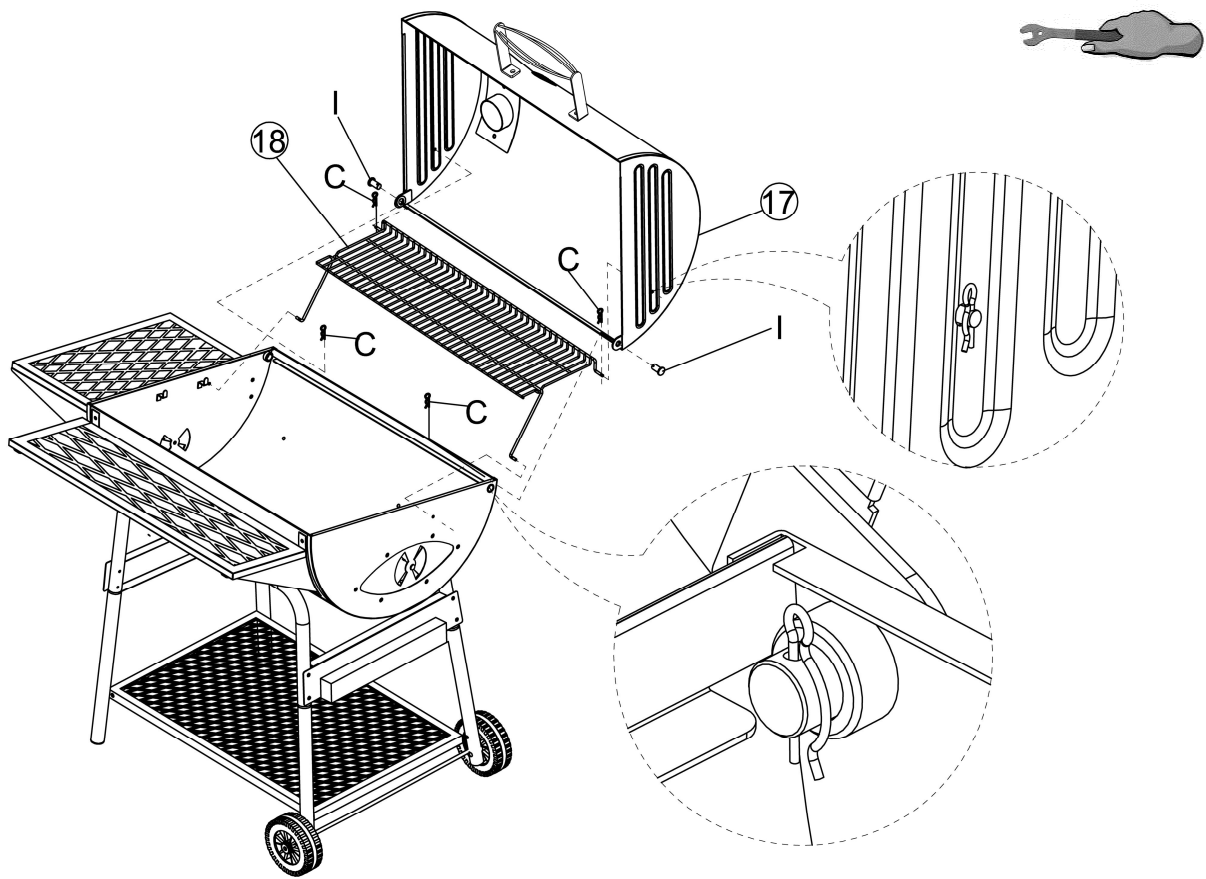

**STEP 8:**

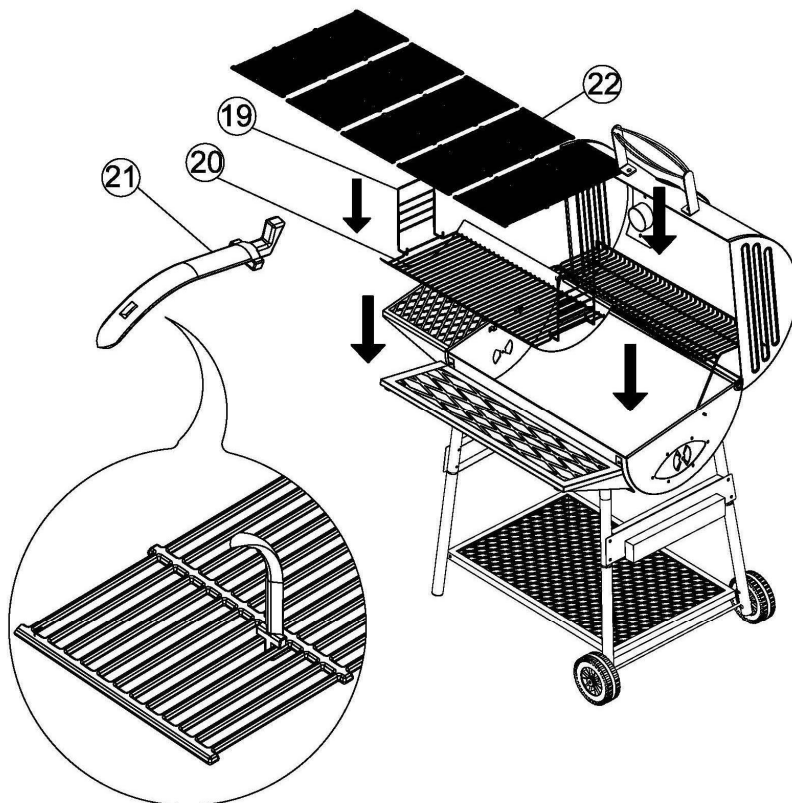

**STEP 9: Tighten all hardware**

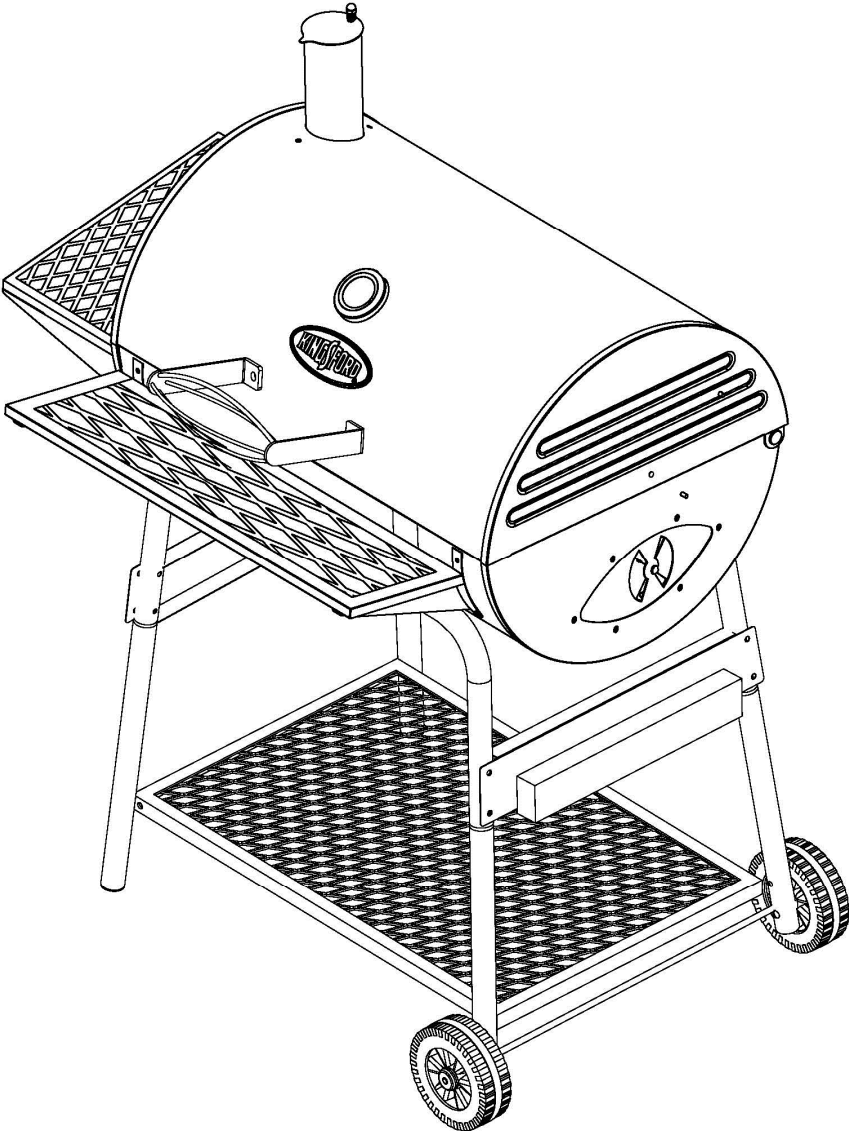



# WARNING



DO NOT use grill without charcoal ash bowl in place. DO NOT attempt to remove charcoal ash bowl while bowl contains hot coals.



# WARNING



Place the grill outdoors on a hard, level, non-combustible surface away from roof overhang or any combustible material. Never use on wooden or other surfaces that could burn. Place the grill away from open windows or doors to prevent smoke from entering your house. In windy weather, place the grill in an outdoor area that is protected from the wind.



# WARNING



Read all safety warnings and instructions carefully before operating your grill.

## PREPARATION FOR USE & LIGHTING INSTRUCTIONS



# WARNING



**OUTDOOR USE ONLY. DO NOT OPERATE GRILL INDOORS OR IN AN ENCLOSED SPACE**  
Never use grill indoors. Carbon Monoxide poisoning can lead to death.

### Curing your grill

#### Step 1

Follow the instructions below carefully to build a fire. You may use charcoal and/or wood as fuel in the grill (see Adding Charcoal/Wood during Cooking+section of this manual).



# WARNING



Use only a high grade plain charcoal or charcoal /wood mixture.

If using a Charcoal Chimney Starter, place lump or briquette charcoal on top of grate in chimney starter until full. Underneath grate place balled up paper and light with match or lighter thru holes in bottom of chimney sides. Once paper lights, fire will spread up thru charcoal until entire column is glowing red in the bottom with ash formation on top. Pick up by handle and pour lit charcoal into grill. **(Proceed to Step 4)**

**NOTE: To extend the life of your grill, make sure that hot coals and wood do not touch the walls of grill.**

#### Step 2

Follow manufacturer's instructions for lighting charcoal.

**Step 3**

With grill lid open, remove the cooking grate (#20), placed the charcoal grate completely inside the grill, stand back and carefully light charcoal. Allow to burn until covered with a light ash (approximately 20 minutes).



# WARNING



Charcoal lighting fluid must be allowed to completely burn off prior to closing grill lid (approximately 20 minutes). Failure to do this could trap fumes from charcoal lighting fluid inside the grill and may result in a flash-fire or explosion when lid is opened.

**Step 4**

With coals burning strong, close the lid. Temperature should exceed 225°F (107°C). Maintain this temperature for 2 hours to remove all traces of paint odor that may remain from the factory.

**Step 5**

Allow the unit to cool.

## OPERATING INSTRUCTIONS

**Step 1**

Lightly coat all cooking surfaces of the grill with vegetable oil or vegetable oil spray.

**Step 2**

Follow the instructions below carefully to build a fire. You may use charcoal and/or wood as fuel in the grill (see %Adding Charcoal/Wood During Cooking+section of this manual).



# WARNING



Use only a high grade plain charcoal or charcoal/wood mixture.

If using a Charcoal Chimney Starter, place lump or briquette charcoal on top of grate in chimney starter until full. Underneath grate place balled up paper and light with match or lighter thru holes in bottom of chimney sides. Once paper lights, fire will spread up thru charcoal until entire column is glowing red in the bottom with ash formation on top. Pick up by handle and pour lit charcoal into grill. **(Proceed to Step 5)**

**NOTE: To extend the life of your grill, make sure that hot coals and wood do not touch the walls of grill.**



# WARNING



DO NOT use grill without charcoal ash tray in place. DO NOT attempt to remove charcoal ash tray while tray contains hot coals.

If you choose to use charcoal lighting fluid, ONLY use charcoal lighting fluid approved for lighting charcoal. Do not use gasoline, kerosene, alcohol or other flammable materials for lighting charcoal. Follow all manufacturer's warnings and instructions regarding the use of their product. Place the charcoal in center of each charcoal grate.

**Step 3**

Follow manufacturer's instructions for lighting charcoal.

**Step 4**

With grill lid open, stand back and carefully light charcoal and allow to burn until covered with a light ash (approximately 20 minutes).



# WARNING



Charcoal lighting fluid must be allowed to completely burn off prior to closing grill lid (approximately 20 minutes). Failure to do this could trap fumes from charcoal lighting fluid inside the grill and may result in a flash-fire or explosion when lid is opened.

## Step 5

Place cooking grid on grill support lips.

## Step 6

Place food on cooking grid and close grill lid. Always use a meat thermometer to ensure food is fully cooked before removing from grill.

## Step 7

Allow grill to cool completely, and then follow instructions in the **After-Use Safety** and **Proper Care & Maintenance** sections of this manual.

## Flavoring Wood

To obtain your favorite smoke flavor, experiment by using chunks, sticks or chips of flavor producing wood such as hickory, pecan, apple, cherry, or mesquite. Most fruit or nut tree wood may be used for smoke flavoring. Do not use resinous wood such as pine as it will produce an unpleasant taste.

Wood chunks or sticks 3+ to 4+ (7 to 10 cm) long and 1+ to 2+ (2 to 4 cm) thick work best. Unless the wood is still green, soak the wood in water for 30 minutes or wrap each piece in foil and tear several small holes in the foil to produce more smoke and prevent the wood from burning too quickly. Only a few pieces of wood are required to obtain a good smoke flavor. A recommended amount for the grill is 5 to 6 wood chunks or sticks. Experiment by using more wood for stronger smoke flavor or less wood for milder smoke flavor.

Additional flavoring wood should not have to be added during the cooking process. However, it may be necessary when cooking very large pieces of food. Follow instructions and cautions in the **Adding Charcoal/Wood During Cooking** section of this manual to avoid injury while adding wood.

## Regulating Heat

To increase heat, add more wood and/or charcoal. Follow instructions in **Adding Charcoal/Wood During Cooking** section of this manual.

To maintain the temperature, you may need to add more wood and/or charcoal during the cooking cycle.

**NOTE:** Dry wood burns hotter than charcoal, so you may want to increase the ratio of wood to charcoal to increase the cooking temperature. Hardwood such as oak, hickory, mesquite, fruit and nut wood are an excellent fuel because of their burning rate. When using wood as fuel, make sure the wood is seasoned and dry. **DO NOT** use resinous wood such as pine as it will produce an unpleasant taste.

## Adding Charcoal/Wood During Cooking

Additional charcoal and/or wood may be required to maintain or increase cooking temperature.

### Step 1

Stand back and carefully open grill lid. Use caution since flames can flare-up when fresh air suddenly comes in contact with fire.

### Step 2

Wearing oven mitts/gloves, use lifter (#21) to lift up the cooking grid and place it on a clean and non-combustible surface. **DO NOT** touch the grid without protection from the heat.

### Step 3

Stand back at a safe distance and use long cooking tongs to lightly brush aside ashes on hot coals. Use cooking tongs to add charcoal and/or wood to charcoal grates. Be careful to avoid over stirring of ashes as this may cause sparks.



# WARNING



Never add charcoal lighting fluid to hot or even warm coals as flashback may occur causing severe burns.

## Step 4

When charcoal is burning strong again, wear oven mitts/gloves and carefully spread the coals for even heat. Extinguish any hot ashes, coals or embers which may have fallen from the grill or beneath and around grill.

## AFTER-USE SAFETY



# WARNING



- Always allow grill and all components to cool completely before handling.
- Never leave coals and ashes in grill unattended. Make sure coals and ashes are completely extinguished before removing.
- Before grill can be left unattended, remaining coals and ashes must be removed from grill. Use caution to protect yourself and property. Place remaining coals and ashes in a non-combustible metal container and completely saturate with water. Allow coals and water to remain in metal container 24 hours prior to disposal.
- Extinguished coals and ashes should be placed a safe distance from all structures and combustible materials.
- With a garden hose, completely wet surface beneath and around the grill to extinguish any ashes, coals or embers which may have fallen during the cooking or cleaning process.
- Cover and store grill in a protected area away from children and pets.

## Proper Care & Maintenance

Vegetable oil provides an excellent defense against rust.

- To protect your grill from excessive rust, the unit must be properly cured and covered at all times when not in use.
- Wash cooking grid and charcoal grate with hot, soapy water, rinse well and dry. Lightly coat grates with vegetable oil or vegetable oil spray.
- Clean inside and outside of grill by wiping off with a damp cloth. Apply a light coat of vegetable oil or vegetable oil spray to the interior surface to prevent rusting.
- If rust appears on the exterior surface of your grill, clean and buff the affected area with steel wool or fine grit emery cloth. Touch-up with a good quality high-temperature resistant paint.
- Never apply paint to the interior surface. Rust spots on the interior surface can be buffed, cleaned, and then lightly coated with vegetable oil or vegetable oil spray to minimize rusting.

## **LIMITED WARRANTY**

1. Manufacturer warrants this Product to be free from defects in workmanship and materials for a period of 1 year from the date of purchase, PROVIDED claims are submitted, in writing, with proof of purchase.
2. If any part of this item fails because of a manufacturing defect within the Limited Warranty Period, Manufacturer offers to replace such part(s) provided that such parts have not been improperly repaired, altered, or tampered with or subject to misuse, abuse or exposed to corrosive conditions. This Limited Warranty is, however, subject to certain limitations, exclusions, time limits and exceptions (Hereinafter ~~Conditions~~) as listed below. Read these Conditions carefully.
3. This Limited Warranty shall be limited to the replacement or repair of any part(s) which Manufacturer determines, after reasonable examination, to have been defective at the time of manufacturing and manufacturer's obligation(s) shall be limited to replacement, if any, of defective part(s) which shall be shipped at Original Purchaser's expense to Original Purchaser's designated shipping address.
4. This Limited Warranty is given to and covers the **ORIGINAL PURCHASER ONLY** and such coverage terminates 1 year from the date of purchase.
5. **DAMAGE LIMITATION WARNING:** IN NO EVENT SHALL MANUFACTURER BE LIABLE FOR ANY INCIDENTAL OR CONSEQUENTIAL DAMAGES, INCLUDING (BUT NOT LIMITED TO) LOSS OF USE OF THE PRODUCT, LOSS OF TIME, INCONVENIENCE, EXPENSE FOR TRAVEL, TRANSPORTATION LODGING EXPENSES, LOSS BY DAMAGE TO PERSONAL PROPERTY OR LOSS OF INCOME, PROFITS OR REVENUE.
6. **MANUFACTURER'S OBLIGATION:** Manufacturer's liability shall be limited to the delivery of a good, merchantable Product and, if necessary, the repair or replacement, at manufacturer's option, of any defective part or unit.
7. **TRANSFER LIMITATIONS:** This Limited Warranty is not assignable or transferable. It covers only the original purchaser.
8. **RESERVED RIGHT TO CHANGE:** Manufacturer reserves the right to make changes or improvements to products it produces in the future without imposing on itself any obligations to install the same improvements in the products it has previously manufactured.
9. This Limited Warranty gives the Original Purchaser specific legal rights but there may be other rights which vary by jurisdiction.

### **IF CUSTOMER SERVICE BECOMES NECESSARY:**

1. The Original Purchaser is responsible for shipping and handling charges of the returned item(s) and replacement parts, if any.
2. All parts to be replaced will need to be shipped before replacement items will be sent.
3. Follow the Customer Service Representative's instructions exactly. If a return is necessary, it must be packed carefully and shipped prepaid.

Should you encounter any problem

**CALL US FIRST.**

Do not return product to the store.

**WE CAN HELP.**

**Rankam Metal Products Manufactory Ltd.**

1618 W. Rosecrans Ave.,  
Gardena, CA90249  
USA

Please contact Rankam Customer Service at [customerservice@rankam.com](mailto:customerservice@rankam.com)  
or at 1-888-837-1380, Mon to Fri, 8:00 a.m. . 5:00 p.m. Pacific Standard Time.

KINGSFORD® AND THE KINGSFORD LOGO ARE REGISTERED TRADEMARKS OF  
THE KINGSFORD PRODUCTS COMPANY, LLC AND ARE USED UNDER LICENSE BY RANKAM METAL  
PRODUCTS MANUFACTORY LTD. ALL RIGHTS RESERVED