



Best Barns USA

Assembly Book

Revised March 6, 2017



the Arlington

Building Size
12' x 16'

Manufactured by Reynolds Building Systems, Inc.

205 Arlington Drive - Greenville, PA 16125

This manual is copyrighted. Under the copyright laws, this manual may not be copied, in whole or in part, without consent from Reynolds Building Systems, Inc. © Copyright 2013

IMPORTANT INFORMATION ABOUT YOUR SHED KIT

This manual will show the assembly for the Arlington building kit. See back page for the breakdown of this material. If you received duplicate books, use the one with the latest revision date. **The foundation is 12'-0" x 15'-9". Do Not make the foundation larger.**

Read the instructions before starting the assembly of the building. If you have any questions about assembling the kit, call 800-245-1577. Business hours (8:00-5:00 ET) Monday thru Friday. After business hours call 724-866-HELP (4357) or email to help@barnkits.com.

The siding, roof sheathing, long framing material and optional floor *if ordered*, will be delivered by a local supplier. The breakdown of this material is listed on the back page. Check to see if you received the correct amount of material before the driver leaves and note any shortage.

The 12' material was shipped in (3) three cardboard packages. The shorter lumber is shipped on a small pallet. Stacking the boards, according to size, will make them easier to find when needed. **Do Not** discard any material, *no matter how small*, until your building is complete.

Paint the bottom edges of the siding around the perimeter of the building. Keep dirt, grass, mulch, snow and similar substances away from the lower part of the siding. The siding manufacturers generally recommend 8" or more of clear space.

Before you begin construction, study this assembly manual. Also, obtain a building permit and check all pertinent building code regulations.

Thank you for your purchase.

Bill & Linda Rinella, owners

Exterior Siding

The siding is made in 4x8 sheets with grooves cut into the face, the long edge is beveled so that the siding overlays where they butt.

To identify which edge we want you to use, we will refer to the edge as either the 'LAP' Edge or the Tongue Edge. Nail siding with 8d galv. nails, spaced 12" apart.

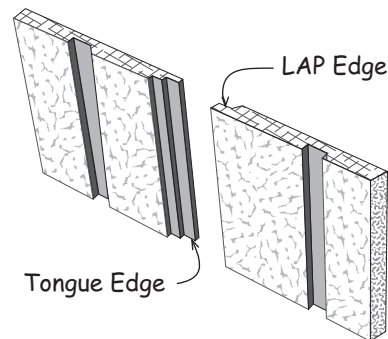

Tool List

- | | |
|--|---|
| <input type="checkbox"/> Hammer & Phillips Screwdriver | <input type="checkbox"/> Power Drill/Screwdriver |
| <input type="checkbox"/> Framing Square & Level | <input type="checkbox"/> Measuring Tape |
| <input type="checkbox"/> Hand or Circular Saw | <input type="checkbox"/> 2-8' Step Ladders & Ladder Jacks |

Always wear safety glasses when cutting or nailing!

Constructing Details for Deluxe Floor System

Deluxe floors include 4x4 runners, standard floors do not

Shown below is a typical wood floor. Depending on your area, the construction may have to be changed to meet local codes. When using a concrete slab for a floor, use the same overall foundation measurements. Install foam sill sealer as a moisture barrier between the concrete and the wall plates. Foam sill sealer is available in rolls, 3-1/2" or wider.

1. Cut (2) two 2x4 joist headers to 15' - 9". Layout for 16" on center joist spacing. 'X' marks where floor joist will be placed.

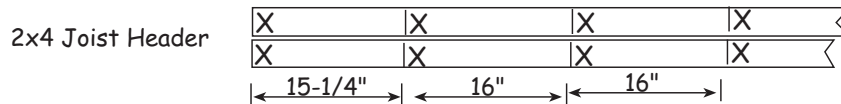

2. Cut 2x4-12' floor joist to 11'-9". *Treated lumber may be thicker than 1-1/2". Take this into account when cutting the length of floor joists. Shorten joist measurements if necessary to obtain 12'-0" building width.*

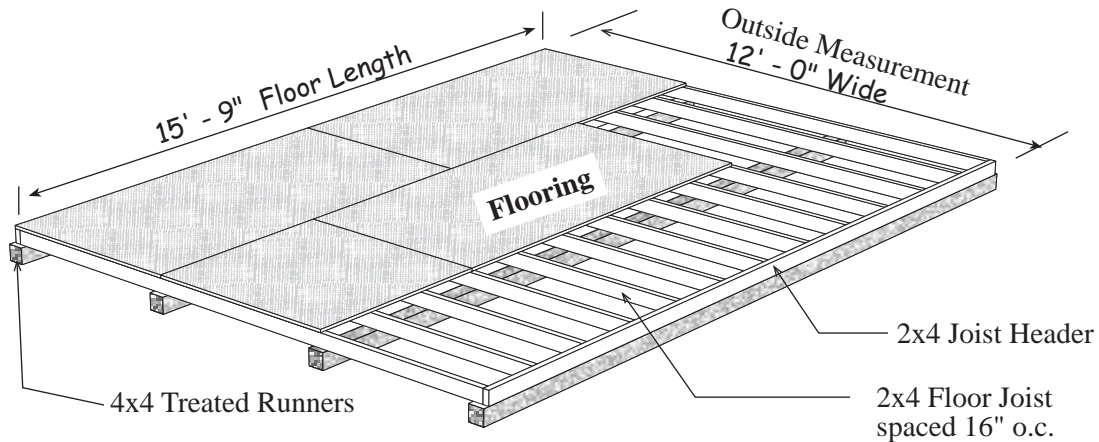

It is important that the floor be level and square. Square the floor as follows: before nailing the flooring, measure the floor diagonally (corner to corner). Then measure the opposite corners. These measurements will be the same if the floor is square.

Material Description	12' x 16' shed
2x4 Joist Headers	2 pcs. 16'
2x4 Floor Joist	13 pcs. 12'
4x4 Treated Runners	8 pcs. 8'
Flooring 5/8" or 3/4"	6 pcs. 4x8
Screw Floor Nails	2 lb. 8d
Galv. Box Nails	2 lb. 16d

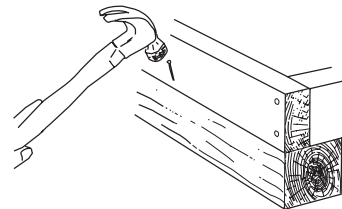

Nail 2x4 joist headers and floor joist to 4x4.

Step 1 Assemble Roof Trusses

1. Locate a 2x4 -12' board, *with angle cuts on both ends*, to be used for the truss bottom.
2. Position 105-3/4" long pre-cut 2x4 rafters on the 12' board.

3. Temporarily tack 2x4 blocks, *packed in kit*, around the truss members. This will insure that the trusses are built exactly the same.

4. Position a 2x4-17-1/2" block at the ridge.

5. Position a 16-3/4" long 2x4 gable stud at each end of the truss.

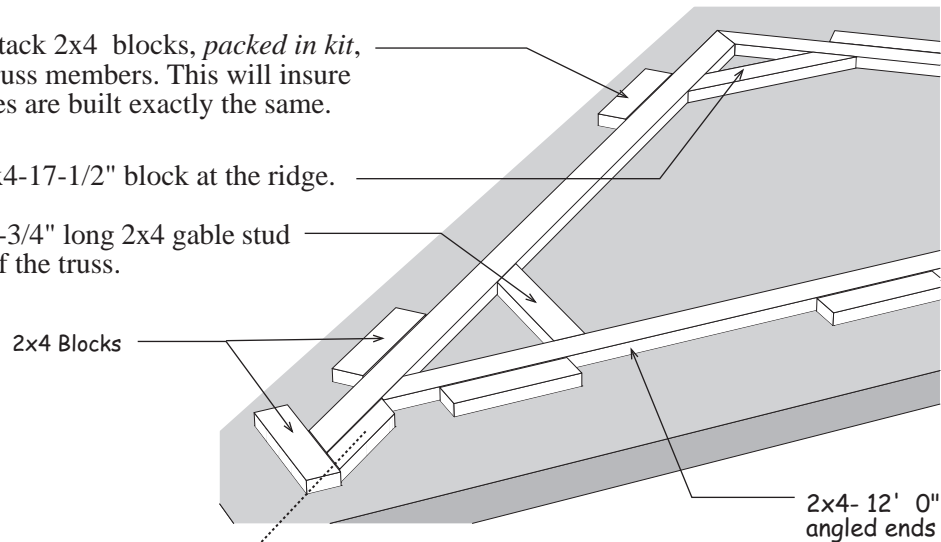

Important: To insure the proper overhang, insert a 11-1/4" long 2x3 gauge block (GB) on each end. Butt the 2x4 truss bottom against the block. Mark this end of the trusses with an 'X' mark. When you install the trusses later, install all the trusses with this end on the same side of the building.

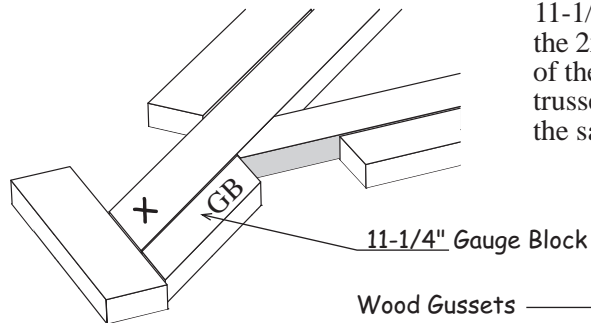

6. Install wood gussets to secure truss parts in place. Apply wood glue between gussets and 2x4s. Secure top gussets with (12) twelve 6d common nails. Secure the lower gussets with (16) sixteen 6d common nails.

7. Turn truss over and apply wood gussets to the opposite side of the trusses.

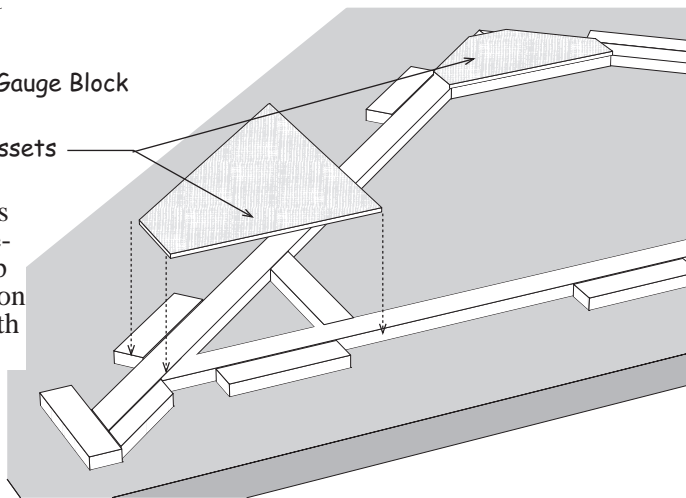

8. Repeat process to assemble (6) six more trusses. Do Not remove the 2x4 blocks around the perimeter of the truss until the gables are assembled in the next step.

Step 2 Assemble Roof Gables

1. Select another 12' long 2x4, *with angle cuts on both ends*. Install pre-cut rafters and bottom gussets as in previous step. Install the bottom gussets on one side only.
2. Install 38-3/4" and 50" long 2x4 gable studs. Secure gable studs with 1" x 4" metal drive-on plates.
3. Install the upper wood gusset, on one side.

4. Position a 2x4-17-1/2" block at the ridge.

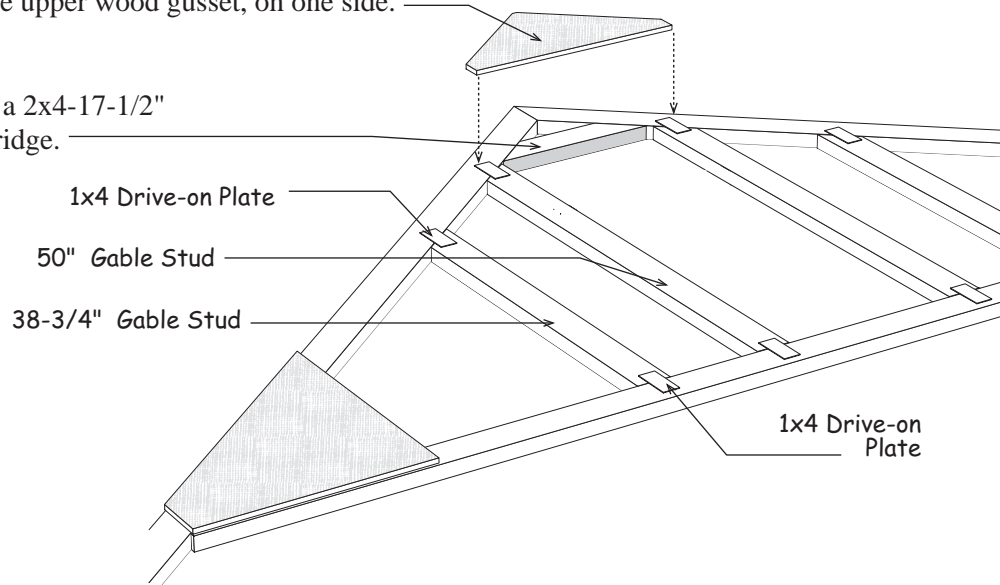

4. Repeat steps to assemble another roof gable.
5. Lay gable on flat surface with gussets facing down.
6. Remove 2x4 blocks used to hold truss parts in place. Secure (3) three blocks, *evenly spaced*, to the bottom 2x4 using 2-1/2" long wood screws.

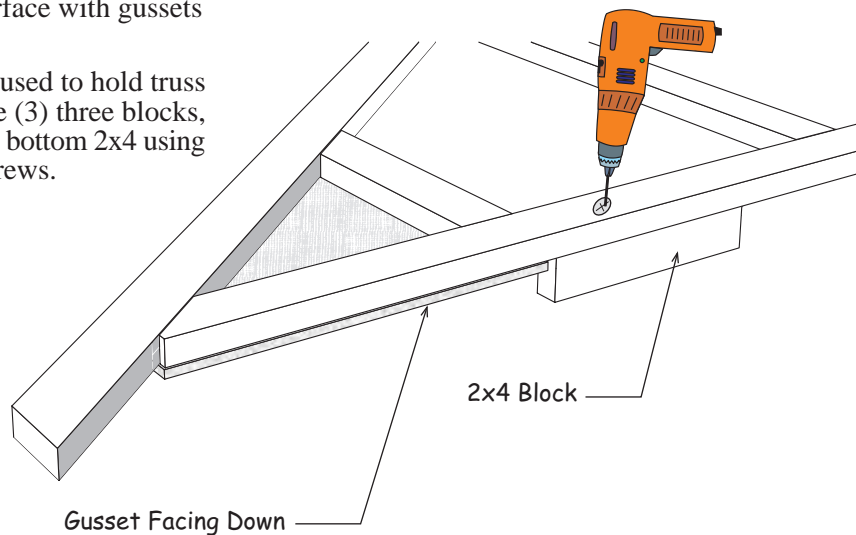

Step 3 Install Siding on Gables

1. Cut a 4x8 siding panel in half creating (2) two 48" siding panels. Install one of the pieces with the 'LAP' edge flush with the end of the bottom 2x4 board and extending 3/4" below the bottom 2x4. Cut siding flush with the top of the gable frame. Secure with 6d galv. nails.
2. Cut a 4x8 siding panel to a length of 66-1/2". Save the cutoff. Install the siding in the center. Cut siding flush with the top of the gable frame.
3. Install the remaining 48" siding panel on the end of the gable.

 Cut the window opening if you are installing the optional gable window. Instructions are packed with window.

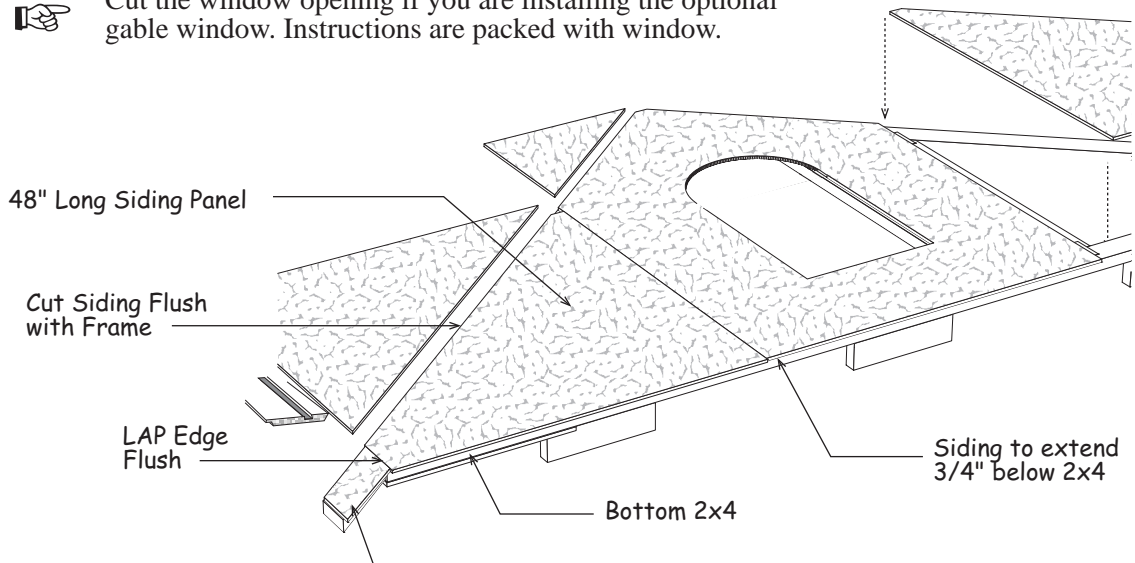

4. Cut siding and install on the ends of the gable. The siding should extend 1/2" below the 2x4 to receive the soffit when installed later.
5. Repeat to install siding on the rear gable.

Step 4 Install Gable Overhang

1. Install (2) two 105-3/4" long 2x4 rafters on the front gable. Install 2x4s extending 1/2" above the top of the gable frame to receive the roof sheathing when applied in a later step.
2. Repeat to install 2x4s on the rear gable.

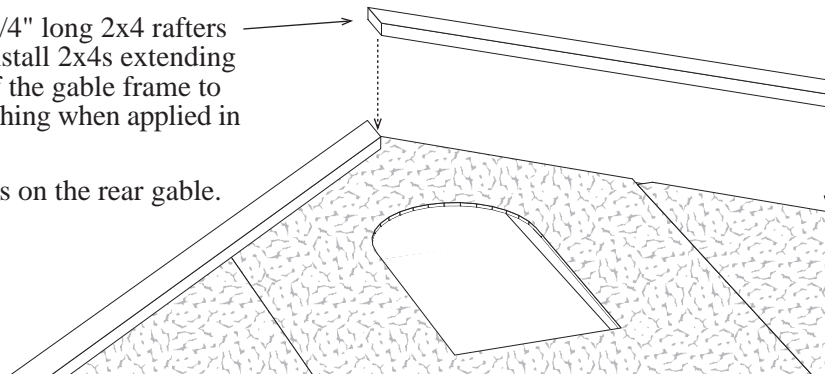

Step 5 Assemble 12' Back Wall (without door opening)

1. Position (4) four 2x4-72" boards together and indicate with 'X' marks, where the wall studs will be located.

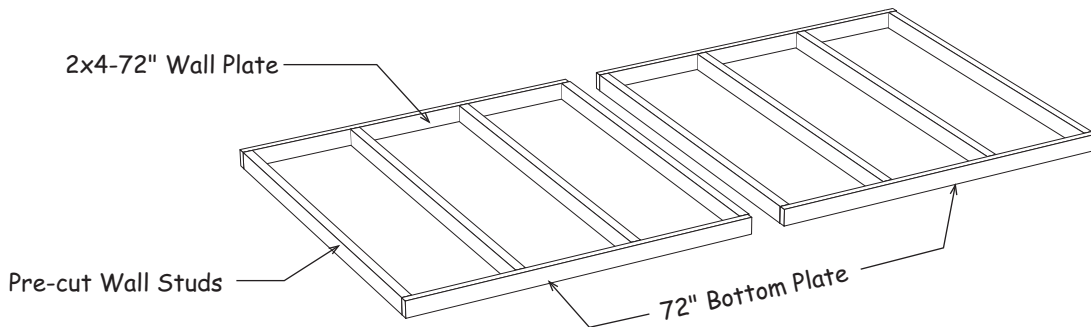
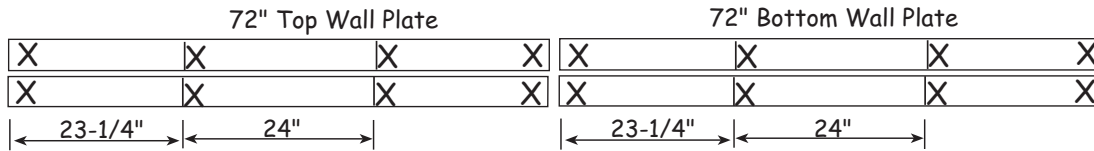

2. Install pre-cut wall studs between the top & bottom plates. Pre-cut wall studs will be 92-5/8" or 92-1/4" in length. Nail studs to wall plates with 10d sinkers, (2) two nails on each end.
3. Nail both wall frames together. Use 10d sinkers.
4. Square wall frame. Measure the wall diagonally (corner to corner). Then measure the opposite corners. These measurements will be the same if the wall is square.
5. Install the first siding panel with the 'LAP edge' flush with the end of the wall and extending 3/4" below the bottom plate. Tip: Use a 1x4 trim board as a gauge. Nail siding with 8d galv. nails, spaced 12" apart.
6. Install (2) two more siding panels. Cut the last panel flush with the end of the frame.

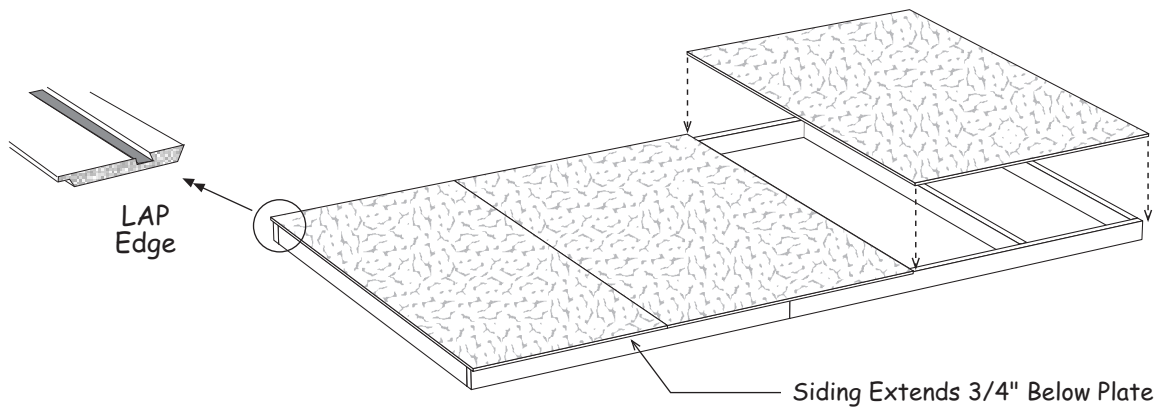

Step 6 Assemble 92-1/2" Long Sidewall

1. Cut (2) two 2x4-8' to a length of 92-1/2". Position the boards together and indicate with 'X' marks where the wall studs will be located.

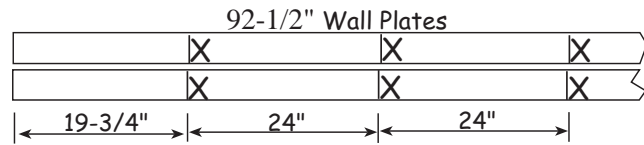

2. Install pre-cut wall studs between the top & bottom plates. Nail studs to wall plates with 10d sinkers, (2) two nails on each end.

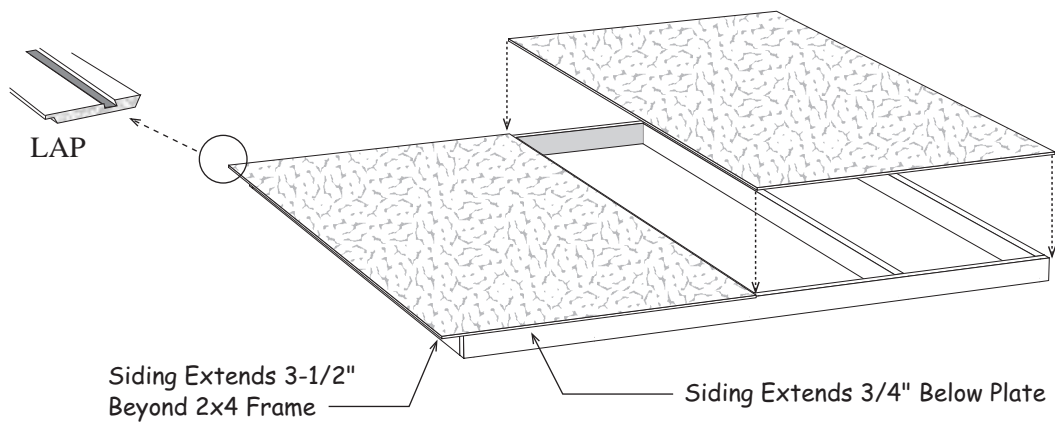
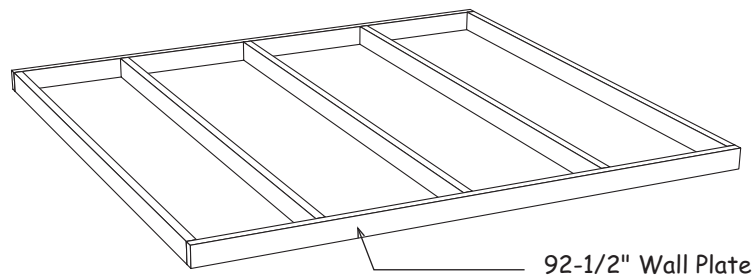

Step 7 Assemble 89-1/2" Long Sidewall

1. Cut (2) two 2x4-8' to a length of 89-1/2". Position the boards together and indicate with 'X' marks where the wall studs will be located.

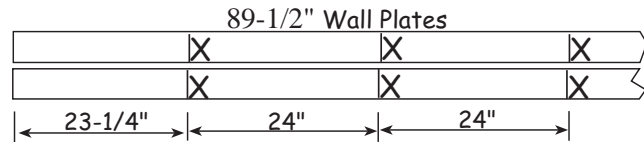

2. Install pre-cut wall studs between the top & bottom plates.
3. Butt wall frame to wall panel from previous step. **Do Not** nail these frames together so they can be separated later.
4. Install a siding panel but do not nail along the long edge that overlaps the other wall frame. You can nail this edge after the wall panels are installed. This will enable you to separate the wall panels making them easier to handle.
5. Cut the last siding panel to a width of 45". The last panel will extend 3-1/2" past the frame.

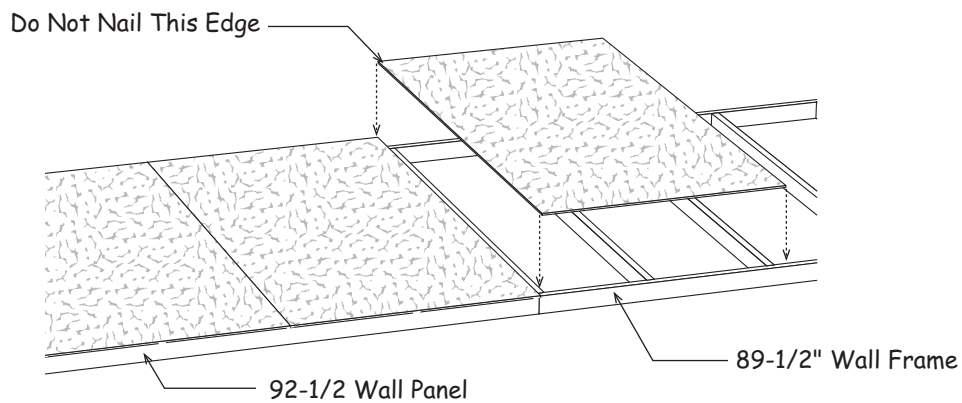

Step 8 Assemble Door Header

1. Cut (2) two 2x4-8' boards to a length of 75".

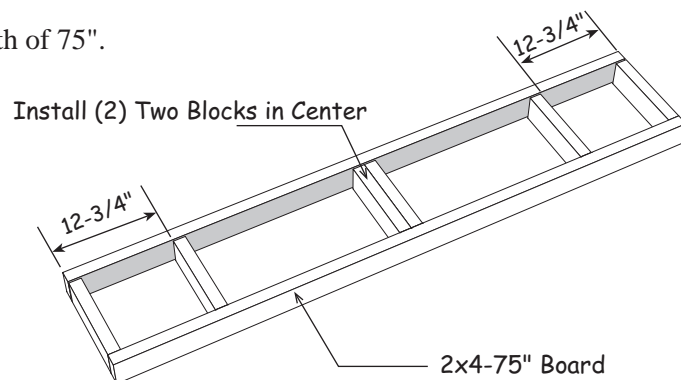

2. Cut (6) six 2x4-11" blocks from another 8' long 2x4.
3. Assemble the door header using 10d sinkers.

Step 9 Assemble 12' Front Wall (with door opening)

1. Gather the material listed below to assemble the door wall.

8	Pre-cut Wall Studs
4	2x4-6' Boards
1	Door Header from Step 8
1	2x4 Block

2. Install (6) six pre-cut wall studs between the 2x4-6' boards where shown. Temporarily secure the bottom 2x4-6' boards together with a 2x4 block.

Install Stud in Center

3. Install the door header at the top of the door opening.
4. Cut and install (2) two pre-cut wall studs under door header.

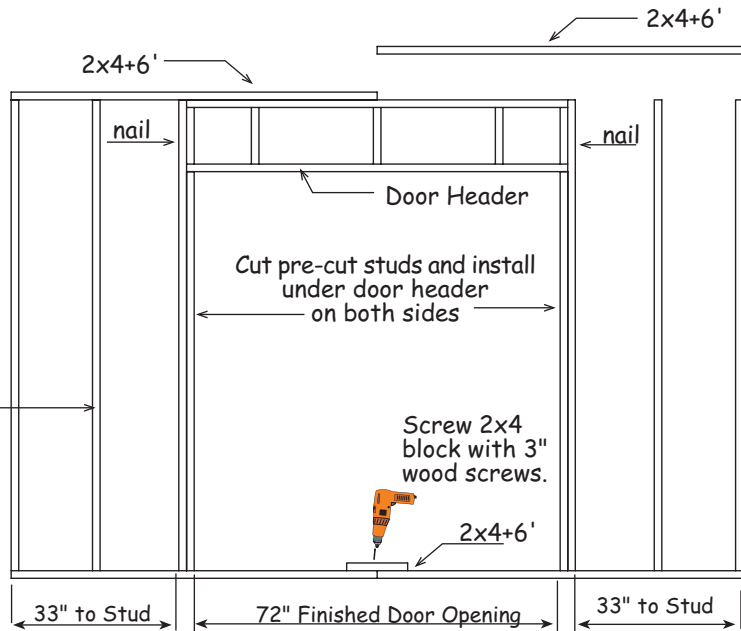

5. Install a 4x8 siding panel on the left side of the wall panel. Before you install the siding, cut and remove the siding that extends into the door opening.
6. Install a siding panel, leftover from **Step 3**, above the door opening.
7. Install another 4x8 siding panel on the right side of the wall panel. Cut and remove the siding that extends into the door opening.

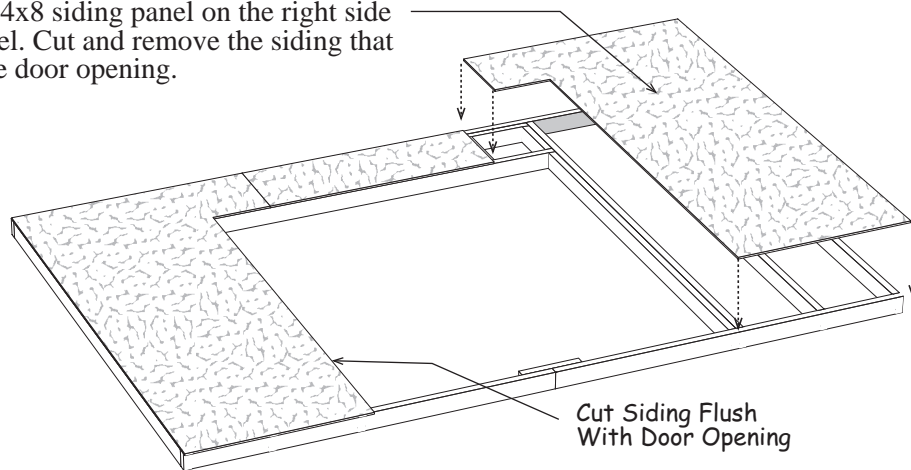

Step 10 Layout Sidewall Plates for Walk-in Door Centered

Cut (2) two 16' long 2x4 boards to a length of 15'-2". Indicate with 'X' marks where the wall studs will be located. Wall frame will be assembled in next step.

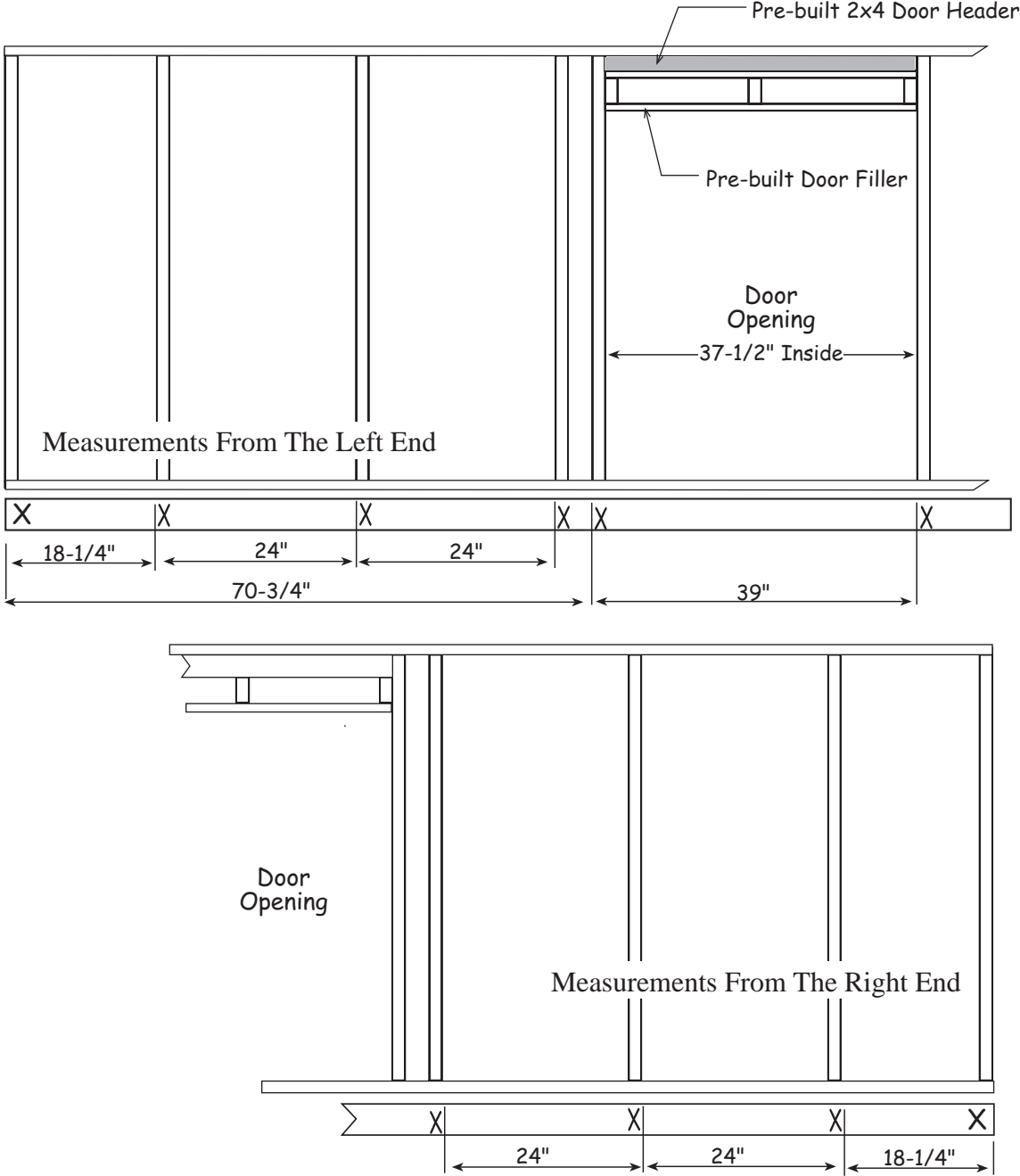

Step 11 Assemble Sidewall

1. Install (10) ten pre-cut wall studs between the 2x4s.
2. Install a pre-built door header, *packed in dormer carton*, between the center wall studs. Nail through top plate. Use 10d sinkers.
3. Cut (2) two pre-cut wall studs to fit as support for header and install. Secure to studs. Use 10d sinkers.

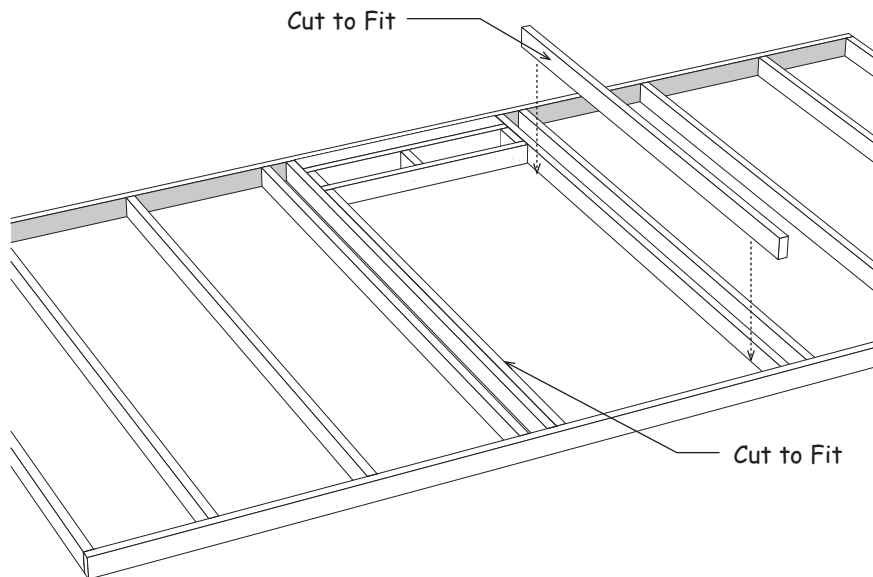

Step 12 Apply Siding to Sidewall Frame

1. Measuring from the 'Tongue Edge' cut a siding panel to a width of $46\frac{1}{2}$ ". Install this panel with the cut edge extending $3\frac{1}{2}$ " past the left end of the wall frame. The siding should extend $\frac{3}{4}$ " below the wall plate.
4. Install a full width siding panel. Locate where you want the window and cut the opening.
5. Install another siding panel. Cut the siding out of the door opening, flush with the side frame and top header.
6. Install another siding panel. Cut out the door opening.

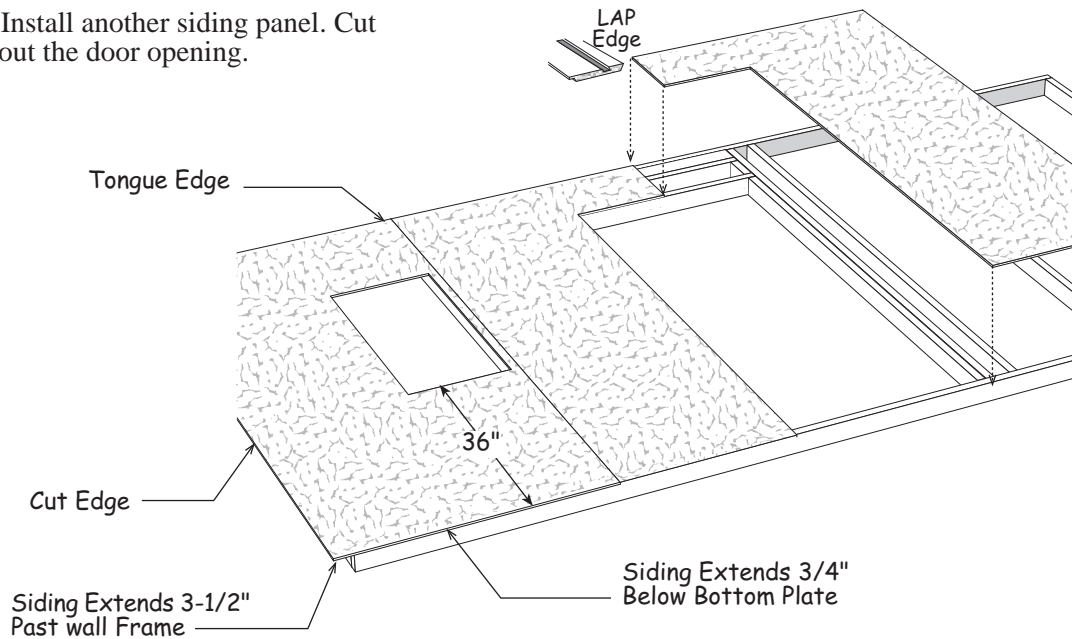

Step 13 Install Last Siding Panel

Cut a siding panel to a width of $46\frac{1}{2}$ " (save the 'LAP edge') and install. The siding panel will extend $3\frac{1}{2}$ " past the end of the wall frame.

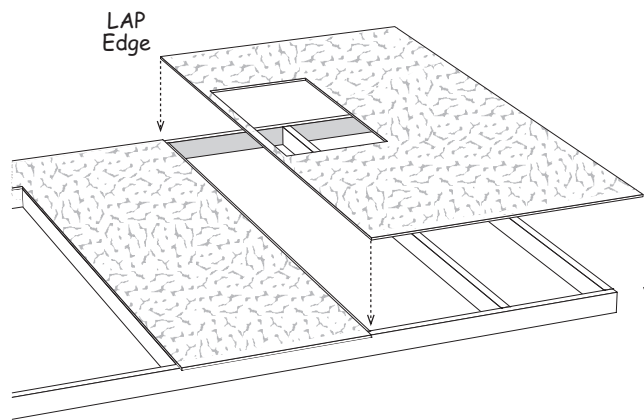

Step 14 Set Wall Panels

1. Set the sidewall panels without door between the front and back walls. Secure wall panels together at the corners. Use (4) four 10d coated nails per corner. Nail through the bottom plate to secure walls. Do not nail in door opening. Space 10d sinkers 24" apart.
2. Nail along the siding edge where the sidewall panels overlap.
3. Install the sidewall with door opening between the front and back walls. Do not nail to floor in door opening.
4. Use pre-cut wall studs at each side of the wider door opening to hold the front wall plumb.
5. Install a pre-cut wall stud to brace the sidewall where the wall panels meet.
6. Insure all walls are plumb.

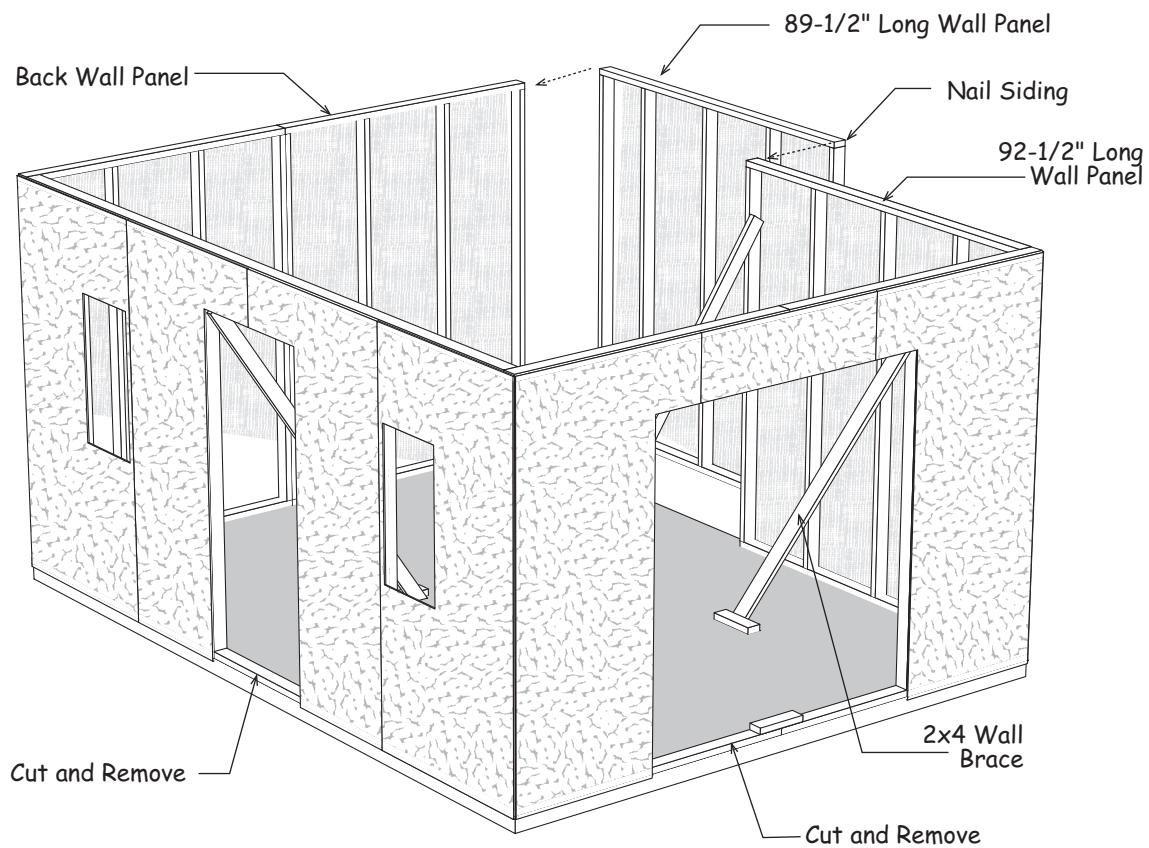

7. Cut and remove the bottom 2x4 in both door openings.

Step 15 Install 2x4 Tie Plates

1. Cut (2) two 2x4-16' boards to a length of 15'-9" and install on the sidewalls, as shown below. Use 10d sinkers.
2. Cut a 6' long 2x4 in half and install 3' long 2x4s on the 12' front and back walls as shown below. Cut to fit and install a 6' long 2x4 between the 3' long 2x4s.

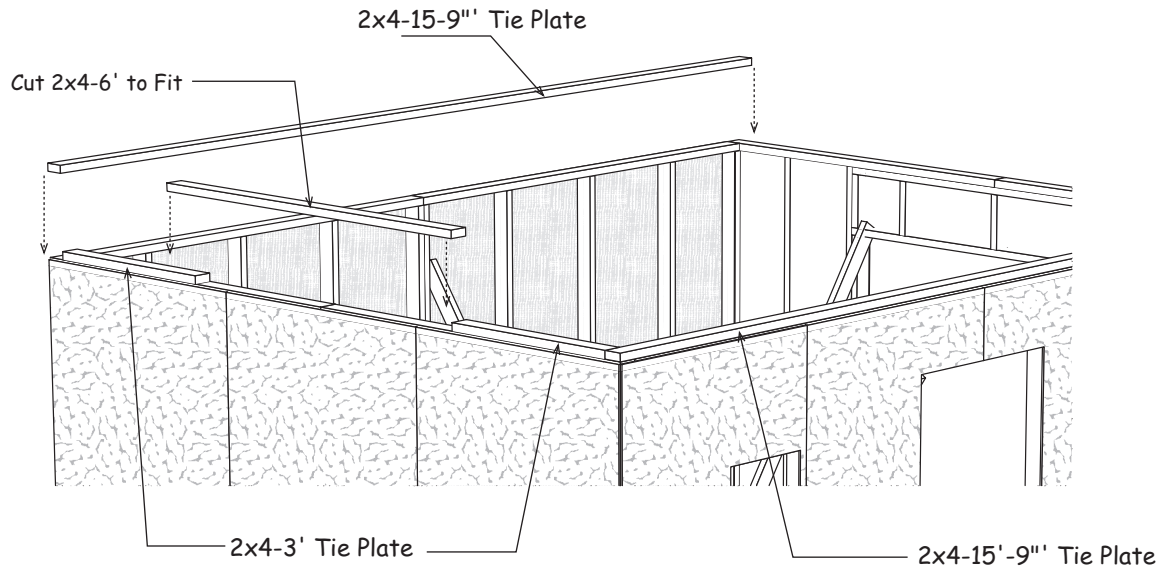

Step 16 Install Corner Trim

IMPORTANT: Lower Trim Must Be Installed Before Installing Roof Gables!

1. Tack 1-1/2" x 48" filler strips on top of the siding on the back wall.
2. Install (2) two 72-3/8" long 1x4 white pine trim boards flush with the siding on the front and back walls and flush with the top of the 2x4 tie plate. Use 8d galv. nails to install all trim.

3. Install 95" long 1x4 white pine trim boards as corner trim on the back wall. Install trim flush with the siding on the sidewalls.
4. Repeat to install trim boards to the front wall.

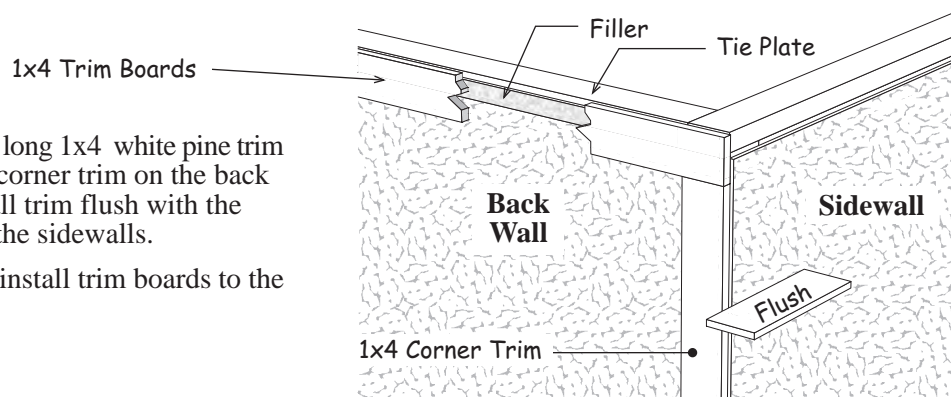

Step 17 Layout Roof Trusses

1. Measuring from back wall trim. Draw a line where the trusses will be positioned. Mark an 'X' to the side of this line.
2. From the first line, draw more lines 24" apart and put an 'X' to the side of these lines. This will place the trusses 24" on center.
3. When installing trusses, position the wood gusset on edge of the line.

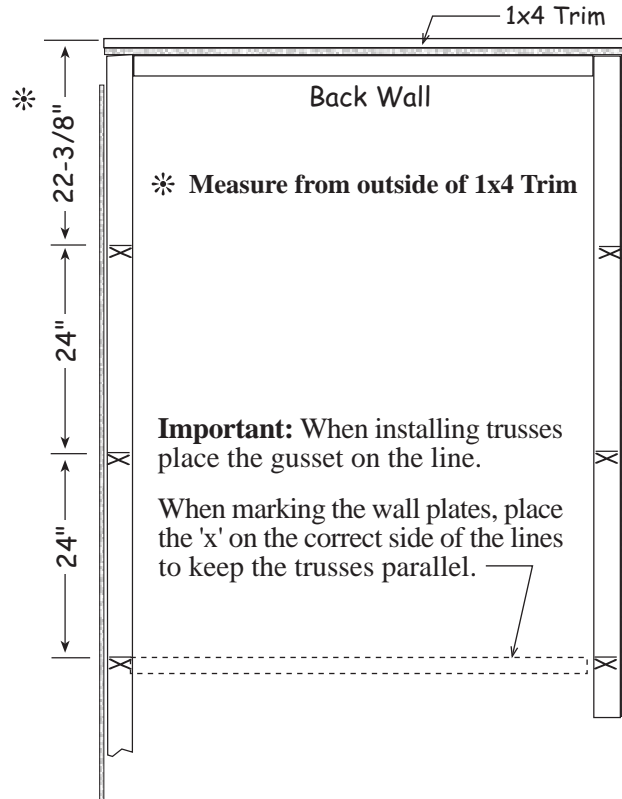

Step 18 Set Back Gable

1. Install gable on the back wall. Secure bottom of gable by nailing gable blocks to wall plate.
2. Nail the bottom edge of the siding into the 1x4 trim. Use 8d galv. nails.

Important: Bottom edge of gable siding extends over 1x4 trim

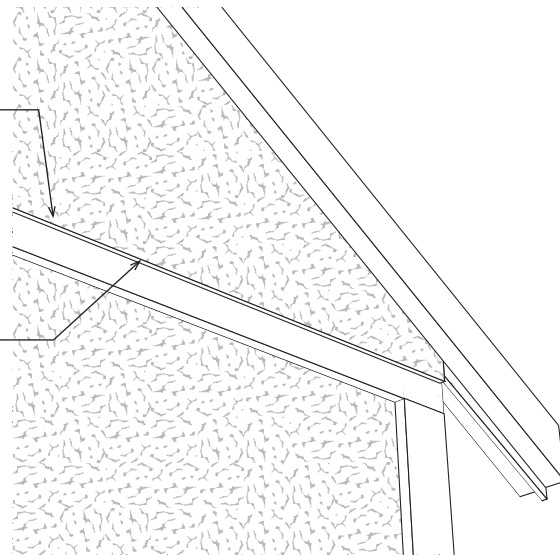

Step 19 Set Trusses

1. Starting from back gable install (4) four trusses with the wood gusset on edge of line and the truss bottom over the 'X' marks.
2. Secure trusses with the metal hangers and 1-1/2" long hanger nails.

IMPORTANT

Secure the trusses to the sidewall that has the wall bracing first. Make sure the opposite sidewall is plumb before securing trusses. The building width should be 12'-0" measuring outside of 2x4 tie plate to outside of 2x4 tie plate.

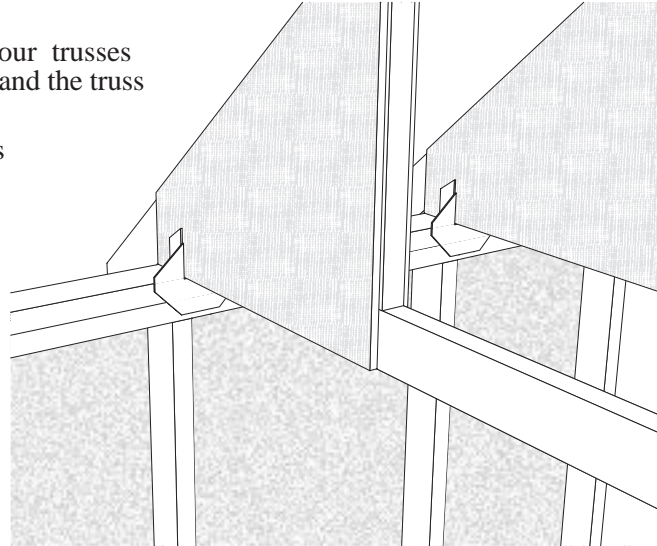

Step 20 Install Loft Flooring

 *Before installing floor sheathing consider the location and size of access opening. Cut sheathing as appropriate.*

1. Install (2) two 4x8 sheets of loft flooring on trusses. Notch floor around studs in the back gable.

Make sure the trusses and walls remain plumb before nailing flooring. Nail floor to bottom 2x4 of gable and trusses with 7d coated nails. Space 12" apart.

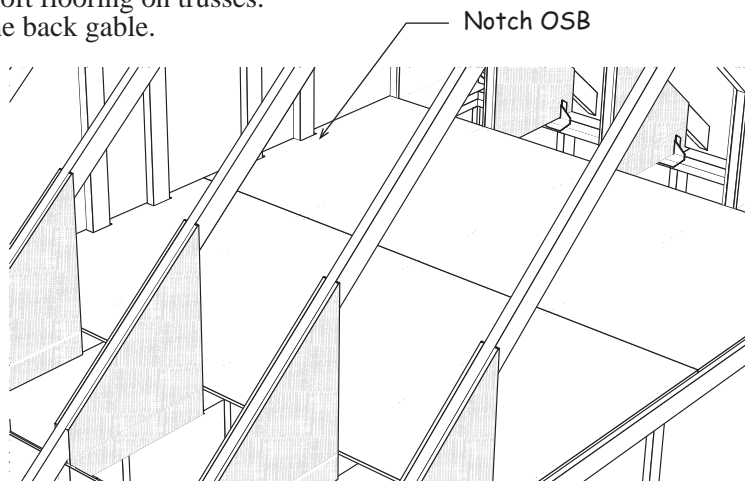

2. If necessary, cut flooring to the center of the 2x4.
3. Continue installing the remaining trusses and front gable.
4. Install 4x8 sheets of loft flooring on trusses at the front of the building.

Step 21 Install Sidewall Trim & Soffit

 *It is easier to install the soffit if the corner and sidewall trim are installed first. This enables the soffit to rest on the trim where it meets the building. See lower detail.*

1. Install a 96-3/4" long 1x4 trim board flush with the corner trim on the back of the building. *This trim board has blue paint on one end.* Locate a 7/16" x 3" x 8" gauge block packed in the hardware bag. Place this gauge block under the truss overhang and butt the corner trim against it. Use 8d galv. nails.
2. Install another 96-3/4" long 1x4 flush with front wall trim.
3. Install 4' long 1x4 trim along the top of the sidewall. Use the gauge block to set where the trim will be installed.
4. Cut to fit and install a 1x4-12' trim board along the top of the sidewall to finish.
5. Repeat on opposite sidewall.

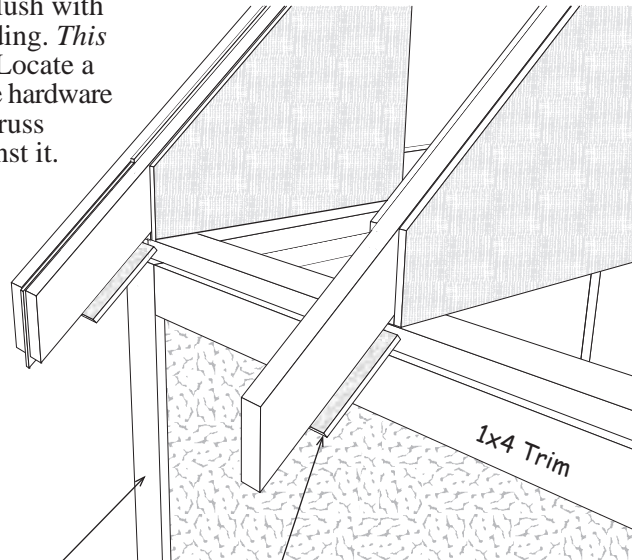

96-3/4' Long Corner Trim

7/16" Gauge Block

6. Starting from back gable install a 4'x10-5/8" soffit panel with bevelled edge. Cut the length so the panel ends at center of 2nd truss. Insure bevelled edge is facing truss ends. Use 6d galv. nails.
7. Install (2) two 6' long soffit panels.
8. Repeat on opposite sidewall.

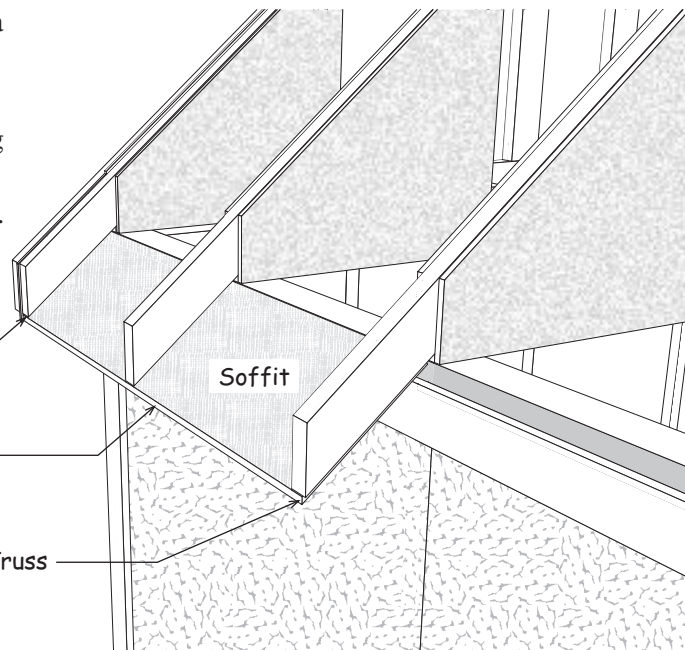

Butt to Gable Siding

Soffit

Bevel Edge

End Center ed Under Truss

Step 22 Install 1x6 Fascia on Sidewalls

1. Starting from back gable install a 121-1/2" long 1x6 trim board flush with the face 2x4 overhang. Install the 1x6 board so the face of the board is aligned with the top of the trusses. Use a straight edge as shown below. Use 8d galv. nails.
2. Cut to fit a 1x6-8' board flush with the 2x4 overhang on the front gable.
3. Repeat on opposite sidewall.

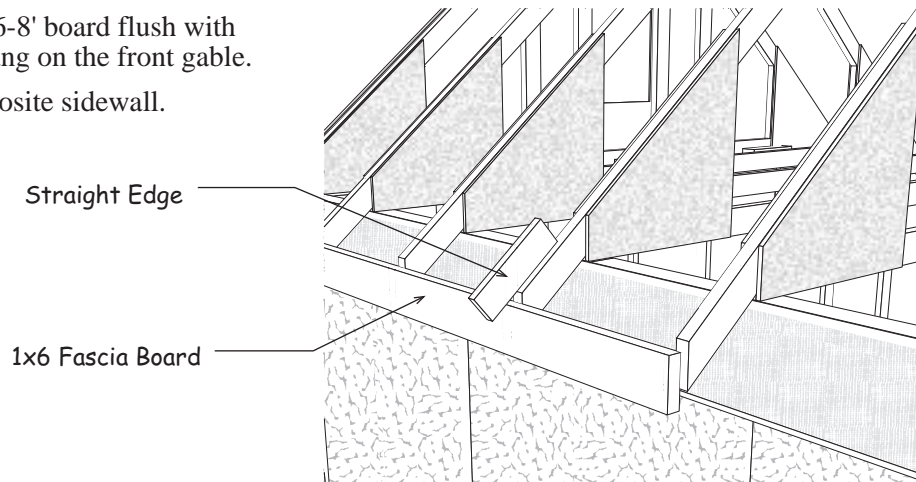

Step 23 Install Sheathing over Sidewall (without door)

1. Install 4x8 roof sheathing starting at the lower left back corner. The bottom edge of the sheathing should extend past the end of the trusses and rest on the 1x6 fascia. Make sure the trusses and gables are plumb and the roof sheathing meets the center of the trusses.
2. Install roof sheathing per layout below. The top row of sheathing is supplied in our component kit. There will be a gap at the top to allow ventilation if ridge vent is applied. Insert (2) two ply-clips into the roof sheathing between each truss at the top row, see drawing on next page. Secure sheathing with 7d sinkers nails. Space nails 12" apart.

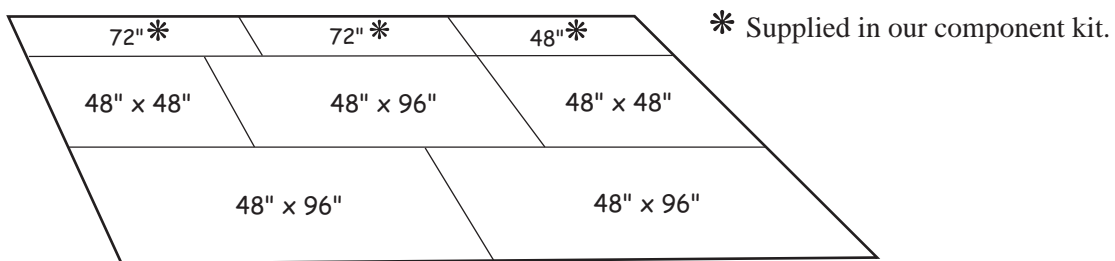

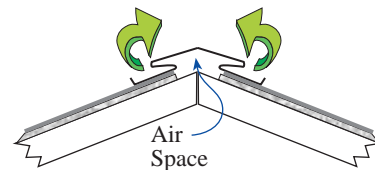

Optional ridge vent provides ideal ventilation.

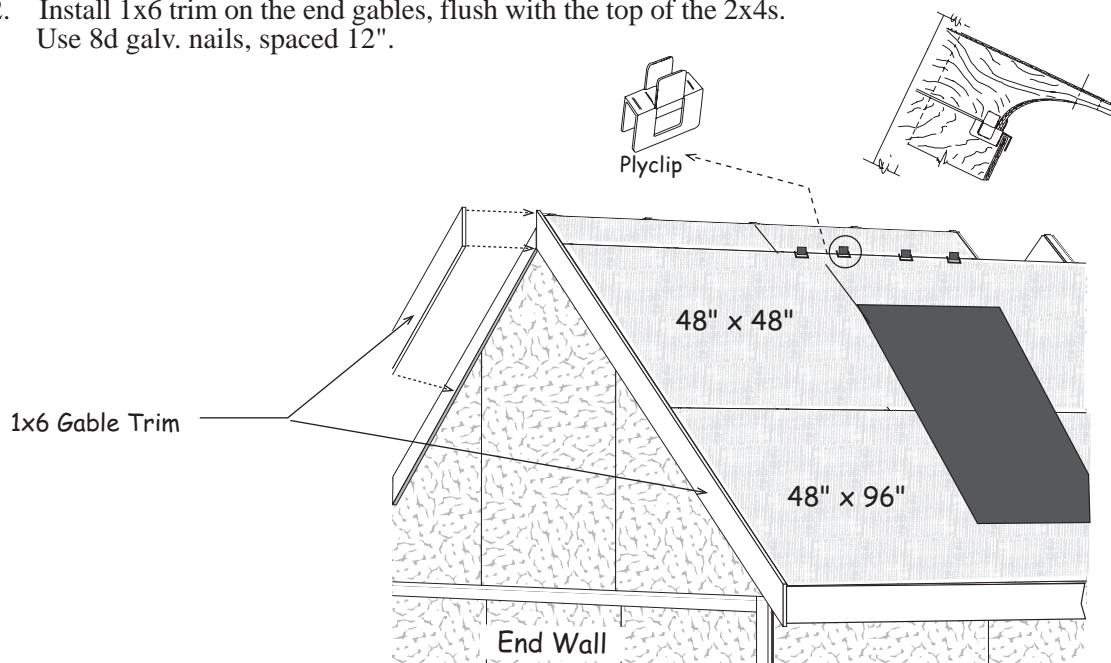

Step 24 Install Roof Sheathing for Dormer side

1. Install 4x8 roof sheathing per layout below
2. Install 1x6 trim on the end gables, flush with the top of the 2x4s.
Use 8d galv. nails, spaced 12".



 You can cut the dormer openings as you install the roof sheathing. See **Step 2** in the Dormer Assembly Book, *packed in the dormer kit*, for the opening sizes.

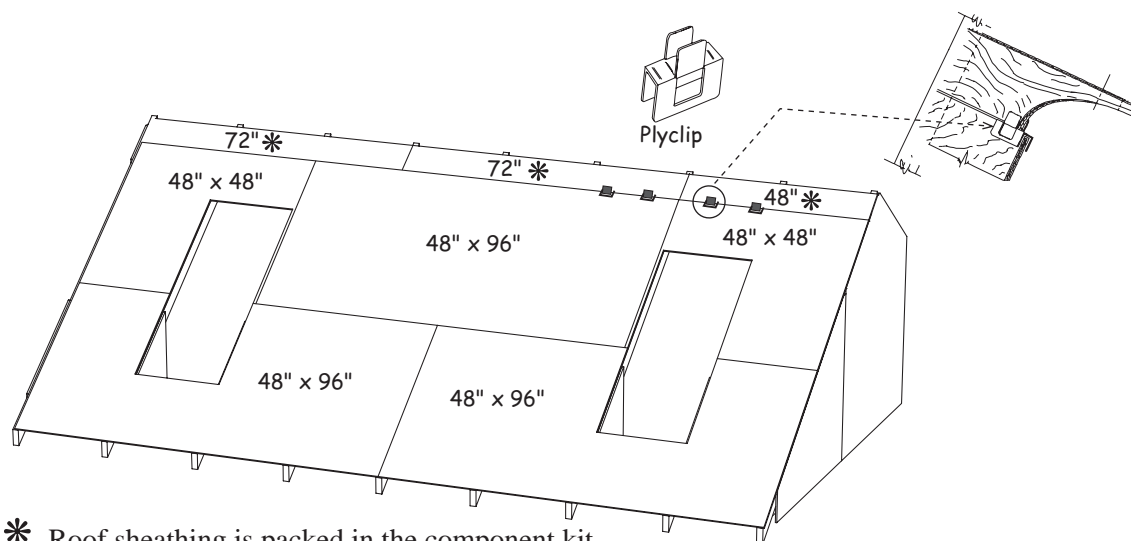

* Roof sheathing is packed in the component kit.

Step 25 Install Front Gable Trim and Door Trim

1. Install 1x6 trim boards over the 2x4 boards, flush with the top of the 2x4s.

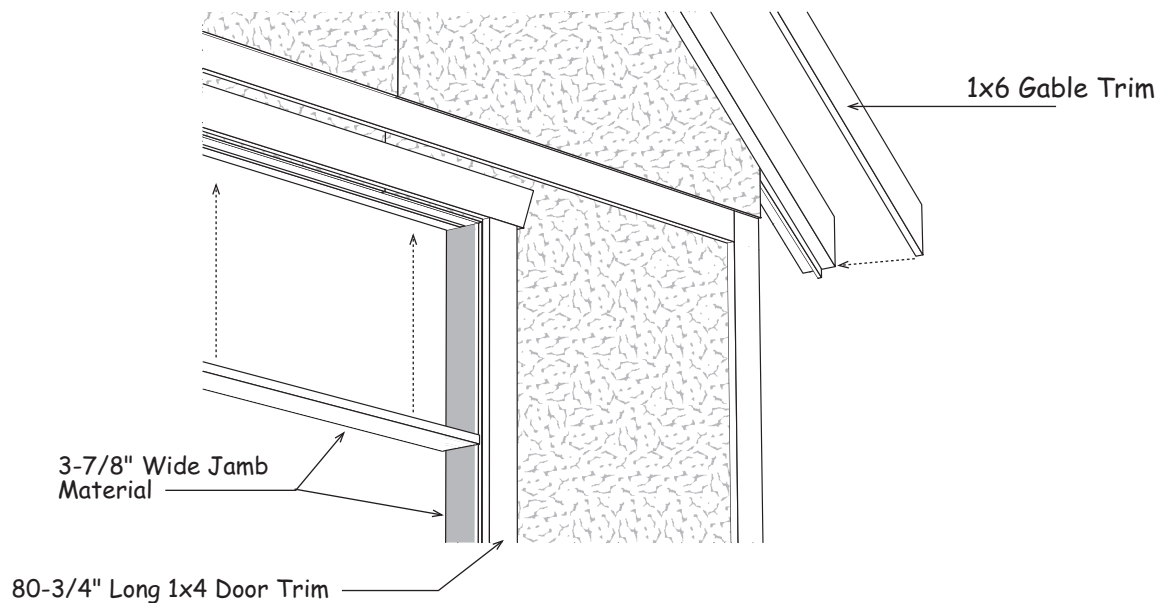

 **Complete the steps below if you are installing wood pocket doors.**

1. Install 3-7/8" x 72" white pine wide jamb material on the top of the door opening.
2. Install 3-7/8" x 79-1/4" white pine wide jamb material on the sides of the door opening.
3. Install 80-3/4" long 1x4 trim boards on each side of the door opening.
4. Install an 82" long 1x4 trim board, *this board has angle cuts on both ends*, across the top of the door opening.

Step 26 Install Roof Dormers and Pocket Doors

1. Install the roof dormers. Refer to the instruction manual packed with the dormer kit.
2. Install the pocket door per the instruction manual packed with the door kit.

Note: The instructions shows the door track being fastened to a door header. For this model you will be installing the tract to the 2x4 studs in the door header.

Install Roofing — Not Supplied in Kit

1. Install metal roof edging along the end walls and the front edge of the roof sheathing.

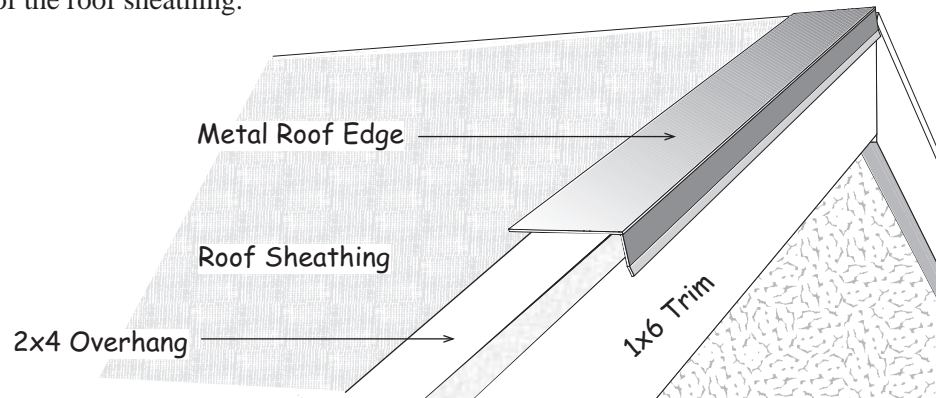

2. Install shingles according to the instructions on the wrapper. If you need more detailed instructions on installing shingles, there are good publications at book stores or newsstands.

<i>Material Packaged In Dormer Component Kit</i>							
4	2x6	Bottom Plates	55-3/4"	2	1 lb. box	8d	Galv. Box
2	2x4	Ridge Boards	56-1/2"	2	1 lb. box	6d	Galv. Box
2	2x4	Bottom Plates	33-1/2"	64	1/2"	White Screws for Windows	
4	2x3	Sidewall Overhang	45-1/4"	40	2-1/2"	Wood Screws	
4	2x3	Gable Overhang	22-3/4"	4	3-1/2"	Wood Screws	
4	1x4	Sidewall Fascia	45-1/4"	1	2"	Bit for Wood Screws	
4	1x4	Gable Trim	23-3/4"	64	5"x7"	Step Flashing	
4	1x3	Side Corner Trim	37"	2	7"x41"	Front Dormer Flashing	
4	1x3	Front Corner Trim	34-1/4"	2	ea.	18" x 23" Windows	
4	7/16"	Roof Sheathing	20-1/2"x 58-3/4"	3	ea.	18" Sunburst Windows	
4	3/8"	Sidewall Siding	4" x 47" angled	4	ea.	Pre-built Angle Sidewall Panels	
2	3/8"	Front Siding	33-1/2" x 49"	2	ea.	Pre-built Frontwall Panels	
1	ea.	Pre-built Header	37-1/2"				

Qty.	<i>Material Packaged In Component Kit</i>			Qty.	<i>Material Packaged In Component Kit</i>		
9	Truss Bottom	2x4	144"	16	7/16"	24" x 11" Truss Gussets	
22	Truss Rafters	2x4	105-3/4"	32	7/16"	24" x 24" Truss Gussets	
12	Wall Plates	2x4	72"	4	7/16"	9-3/4" x 72" Sheathing	
4	Gable Studs	2x4	50"	2	7/16"	9-3/4" x 48" Sheathing	
4	Gable Studs	2x4	38-3/4"	2	3/8"	Soffit Boards 4' x 10-5/8"	
22	Gable & Truss Studs	2x4	16-3/4"	4	3/8"	Soffit Boards 6' x 10-5/8"	
9	Truss Blocks	2x4	17-1/2"	5	lbs.	10d	Sinkers
4	White Pine Trim	1x4	72-3/8"	5	lbs.	8d	Galv. Nails
2	White Pine Wall Trim	1x4	48"	3	lbs.	7d	Sinkers
2	White Pine Wall Trim	1x4	144"	2	lbs.	6d	Galv. Nails
4	White Pine Corner Trim	1x4	95"	5	lbs.	6d	Common
4	White Pine Corner Trim	1x4	96-3/4"	1	lbs.	1-1/2"	Hanger Nails
4	White Pine Gable Trim	1x6	107"	24	2-1/2"	Wood Screws	
2	White Pine Fascia	1x6	121-1/2"	14	H11z	Truss Hangers	
2	White Pine Fascia	1x6	96"	34	Plyclips for Roof Sheathing		
2	Truss Gauge Blocks	2x3	10-5/8"	22	1x4	Drive-on Metal Plates	
10	Truss Jig Blocks	2x4	10"	3	16 oz.	Bottles Wood Glue	
2	Soffit Gauge Blocks	7/16"	3" x 8"	2	18" x 36" Windows w/ shutters		
6	48" Long Filler Boards	3/8"	x 1-1/4"				
1	32" Entry Door w/lockset - This door will be shipped by local supplier						

Qty.	<i>Material Supplied by Local Supplier</i>	
42 pcs.	2x4-Pre-cut Wall Studs	
7 pcs.	2x4-8' Wall & Tie Plates	
4 pcs.	2x4-16' Wall & Tie Plates	
17 pcs.	Exterior Siding	4x8
8 pcs.	OSB Sheathing	4x8
4 pcs.	OSB Loft Floor	4x8

Optional Roof Covering

12 bdl. Roof Shingles
8 pcs. Roof 'drip' Edge-10'