

Troubleshooting Tips

Top Tips

Always turn the handwheel towards you

- Counterclockwise.

No Power

- Check main power supply is turned on, power cord and foot control are connected.

Machine Not Feeding Fabric

- Check that the Feed Dogs are raised and clean. These are the teeth under the presser foot that feed the fabric when stitching. When the drop feed lever is moved from the lowered position to the raised position the feed teeth do not come up at the needle plate until you turn the handwheel wheel towards you.
- Check that the stitch length is set for correct weight of fabric.

Skipped / Bad Stitching

- Rethread the machine with the presser foot raised and the take up lever in the highest position. Follow the threading guides and check that the thread is in the take up lever.
- Check that the needle is inserted correctly, flat side to the back.
- Check that the needle is not bent or blunt and is the correct type of needle.
- Check that the tension setting is correct (average setting for a straight stitch is approx. 4).
- Check that the tension disc area is clean.
- Check that the bobbin is placed in the bobbin case correctly.

Register your machine today to receive emails with special offers, new accessories, tips, tricks, inspiration, tutorials and more.

janome.com • janome.ca

Happy Sewing!



Ready-Set-Sew Getting Started Guide

Congratulations on the purchase of your new sewing machine. We've compiled a few tips that will help you get the most out of your new purchase and increase your enjoyment of sewing.

Note: Your machine may vary from these illustrations. Always refer to your instruction manual for exact details on your machine.

Bobbin Winding

In order to ensure correct bobbin winding, follow the below diagram for correct threading. Use both hands to thread machine around the guide for correct tension.

Pro tip: Because different brands of thread unwind in various manners, sometimes it is helpful to lightly hold the thread as it comes off the spool. This will help create smooth and tightly wound bobbins - which is important for a good stitch.

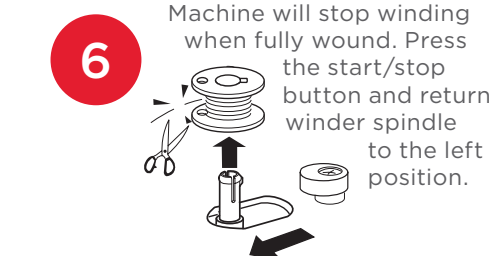
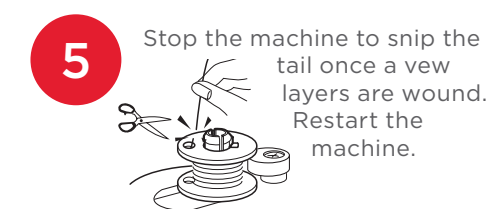
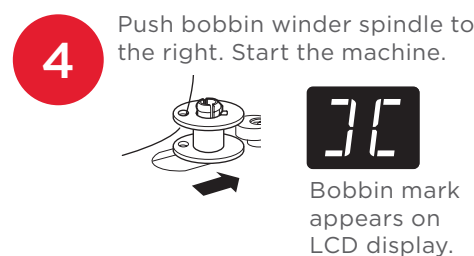
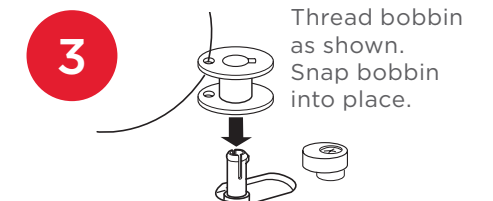
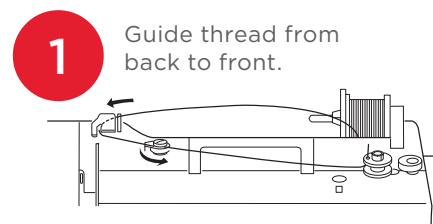

Top Threading

Before you begin to thread, make sure the presser foot is in the **up** position and the needle is at the highest position. Lift the foot by using the presser foot lifter behind the machine. To raise the needle, always turn the handwheel on the right side of the machine toward you. This will help ensure that the threading guides are in the proper position to receive the thread.

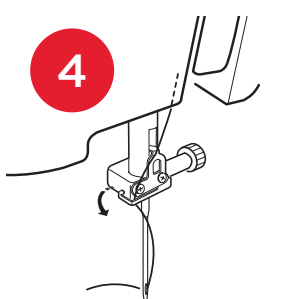
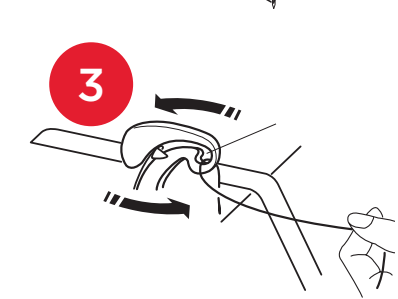
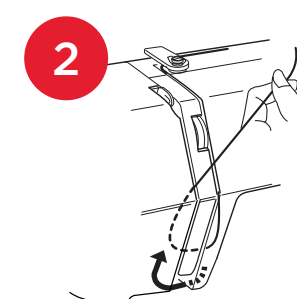
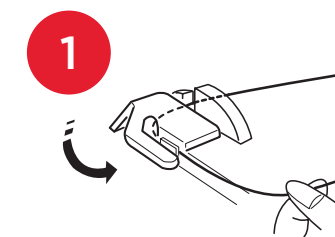
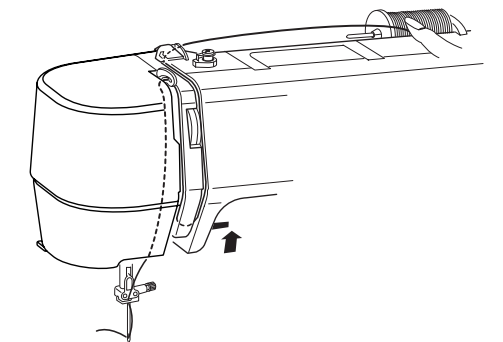

Getting Started Guide

Using the Needle Threader

Raise the needle to its highest position. Pull down the needle threader knob as far as it will go. Turn the knob in the direction of the arrow in the second illustration, then insert the Hook into the needle eye. Lead the thread around the Guide and under the Hook. Turn the knob in the direction of the arrow in the third illustration, drawing the thread loop through the needle. Pull the thread through the needle eye.

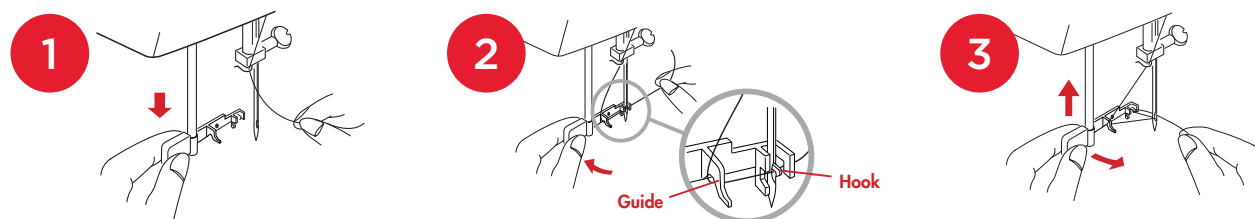

Bobbin Threading

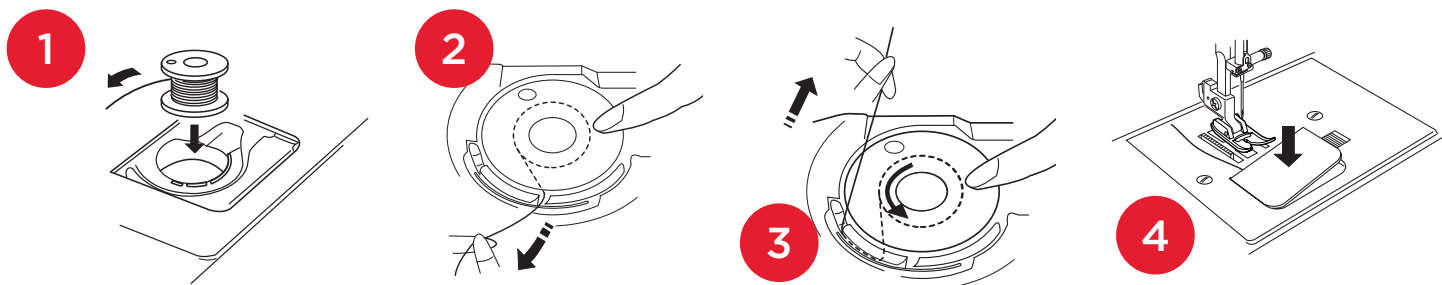

Before inserting the bobbin into the bobbin case, hold the bobbin in your hand and make sure that the thread is coming off the bobbin in a counterclockwise direction (it should look like a "P"). This will allow the bobbin thread to move correctly and to stay lodged in the bobbin tension guide.

Picking up the Bobbin Thread

Before you begin to sew, the bobbin thread needs to be pulled up onto the sewing bed. Gently hold the needle thread and turn the handwheel towards you. In approximately two rotations, you will see the bobbin thread looped around the needle thread. Using your fingers, grab the bobbin thread and pull up a 6" length.

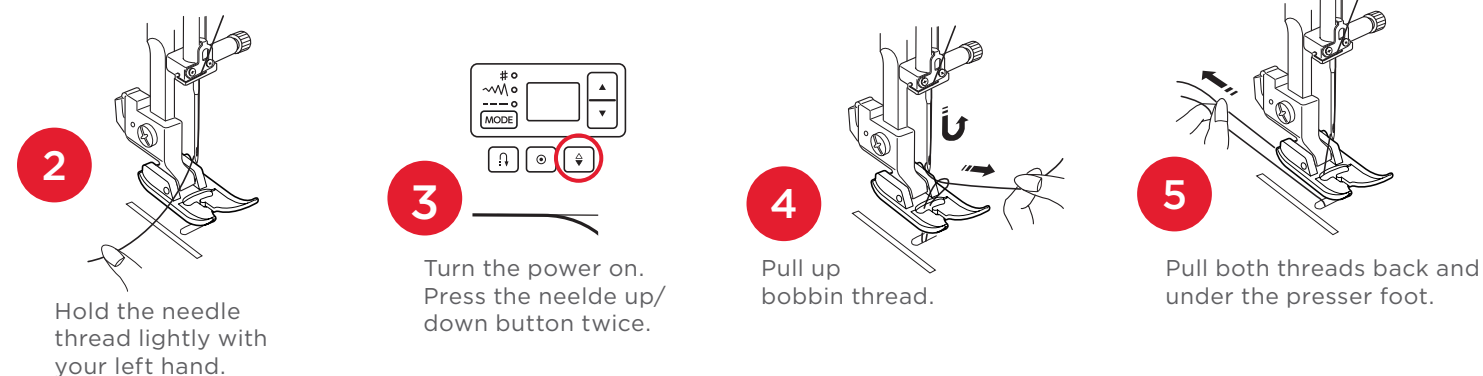

Common Sewing Situations

Sewing Over Thick Fabrics

Even though sewing machines can handle all types of fabrics, it's important to keep in mind that when sewing on thick fabrics like denim, that seams can become very thick. It is important to keep the presser foot level when sewing over these seams or uneven surfaces.

Pro tip: A quick fix is to fold a scrap of fabric 2 - 3 times and put it behind the needle and underneath the presser foot when you approach the seam or hump in your fabric. This will help to level your foot and keep your fabric feeding correctly.

The Thread Loops on the Underside or Topside of the Fabric

Pro tip: Problems with your seam are the opposite of what you might think. If the thread is looping on the underside of your seam, re-check the upper threading on your machine. The thread may not be correctly seated in the thread guides or has come out of the Take Up lever.

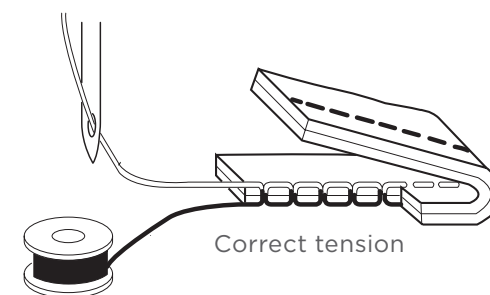

Conversely, if the thread is looping on top, make sure the bobbin thread is coming off the bobbin counterclockwise and that the thread is securely threaded in the bobbin tension guide.

Refer to your instruction manual for more information.

Machine or Needle is Jammed

Using scissors, carefully cut away thread above and below your fabric. Gently pull the fabric away from the presser foot area, while making slight turns on the handwheel to raise the needle.

Inspect the needle to make sure it isn't bent. If so, replace it. Before re-threading the needle, turn the handwheel toward you, making sure that there isn't any more thread or fabric in the feed dogs or in the bobbin area.

Pro tip: When you are done sewing a seam, make sure that the needle is in the highest position before you remove your fabric from the machine. This will ensure that the upper thread has made a full rotation around the bobbin case, preventing thread jams in the bobbin area.

Machine Won't Turn On

Check to make sure that the cord is plugged into the wall.

Check to make sure that the power cord is plugged into the sewing machine.

