

**JOHN DEERE**  
**WORLDWIDE COMMERCIAL & CONSUMER**  
**EQUIPMENT DIVISION**

---

**Utility Cart**  
**7P**

**OMM162147 L9**

**OPERATOR'S MANUAL**



**JOHN DEERE**

**Original Instruction**

All information, illustrations and specifications in this manual are based on the latest information at the time of publication. The right is reserved to make changes at any time without notice.

**COPYRIGHT© 2009**

**Deere & Co.**

**John Deere Worldwide Commercial and  
Consumer Equipment Division**

**All rights reserved**

**Previous Editions**

**COPYRIGHT©**

**North American Version**

**Litho in U.S.A.**

# PRODUCT IDENTIFICATION

## Product Identification

### Product Compatibility

This utility cart is designed for use with lawn tractors and lawn and garden tractors.

### Record Purchase Information

Record your purchase information in the spaces provided below.

DATE OF PURCHASE:

\_\_\_\_\_

DEALER NAME:

\_\_\_\_\_

DEALER PHONE:

\_\_\_\_\_

## Safety Labels

### Safety Label Location

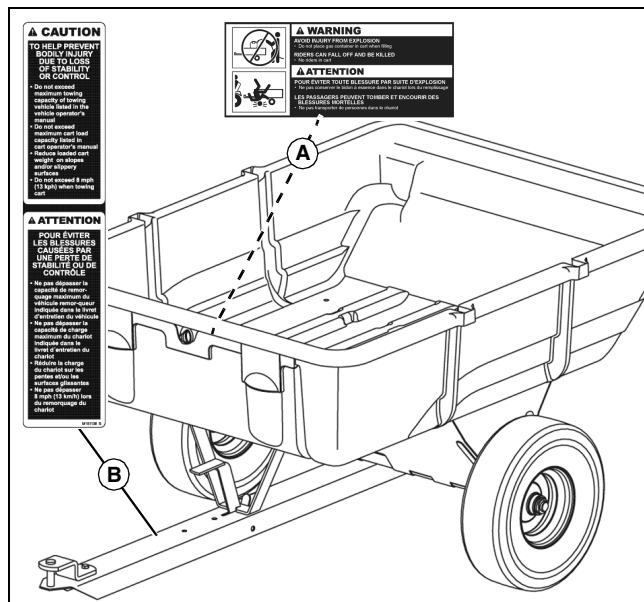

MX27744, M151136B, 1007398

Picture Note: Use label number listed in table below to locate complete text of safety label message following this illustration.

A- WARNING - 1007398

B- CAUTION - M151136

## Safety Labels



### Understanding The Machine Safety Labels

The machine safety labels shown in this section are placed in important areas on your machine to draw attention to potential safety hazards.

On your machine safety labels, the words DANGER, WARNING, and CAUTION are used with this safety-alert symbol. DANGER identifies the most serious hazards.

The operator's manual also explains any potential safety hazards whenever necessary in special safety messages that are identified with

the word, CAUTION, and the safety-alert symbol.

There can be additional safety information contained on parts and components sourced from suppliers that is not reproduced in this operator's manual.

### WARNING 1007398



1007398

#### AVOID INJURY FROM EXPLOSION

- Do not place gas container in cart when filling
- RIDERS CAN FALL OFF AND BE KILLED
- No riders in cart

#### CAUTION



M151136

#### TO HELP PREVENT BODILY INJURY DUE TO LOSS OF STABILITY OR CONTROL

- Do not exceed maximum towing capacity of towing vehicle listed in the vehicle operator's manual.
- Do not exceed maximum cart load capacity listed in cart operator's manual.

---

---

# SAFETY

---

---

- Reduce loaded cart weight on slopes and/or slippery surfaces.
- Do not exceed 8 mph (13 kph) when towing cart.

---

---

## Safety

### Read Safety in Machine Operator's Manual

Read the general safety operating precautions in your machine operator's manual for additional safety information.

### Operate Safely

- This attachment is intended for use in lawn care and home applications. Do not tow behind a vehicle on a highway or in any high speed application. Do not tow at speeds higher than maximum recommended towing speed.
- Towing speed should always be slow enough to maintain control. Travel slowly over rough ground.
- Do not let children or an untrained person operate machine.
- Do not let anyone, especially children, ride on machine or attachment. Riders are subject to injury such as being struck by foreign objects and being thrown off. Riders may also obstruct the operator's view, resulting in the machine being operated in an unsafe manner.
- Check machine brake action before you operate. Adjust or service brakes as necessary.
- Keep all nuts and bolts tight to be sure the equipment is in safe working condition.
- Keep all parts in good condition and properly installed. Fix damage immediately. Replace worn or broken parts. Replace all worn or damaged safety and instruction decals.
- Do not modify machine or safety devices. Unauthorized modifications to the machine or attachment may impair its function and safety.
- Securely anchor all loads to prevent loads from falling.
- Distribute load evenly for safe travel and unloading of cart.
- Do not obstruct the operator's view during use.

### Towing Loads Safely

- Stopping distance increases with speed and weight of towed load. Travel slowly and allow extra time and distance to stop.
- Total towed weight must not exceed limits specified in towing vehicle operator's manual.
- Excessive towed load can cause loss of traction and loss of control on slopes. Reduce towed weight when operating on slopes.
- Never allow children or others in or on towed equipment.
- Use only approved hitches. Tow only with a machine that has a hitch designed for towing. Do not attach towed equipment except at the approved hitch point.
- Follow the manufacturer's recommendations for weight limits for towed equipment and towing on slopes. Use counterweights or wheel weights as described in the machine operator's manual.
- Do not turn sharply. Use additional caution when turning or operating under adverse surface conditions. Use care when reversing.
- Do not shift to neutral and coast downhill.

### Protect Bystanders

- Keep bystanders away when you operate a towed attachment.

- Before you back machine and attachment, look carefully behind attachment for bystanders.

### Keep Riders Off Towed Attachment

Keep riders off of a towed attachment.

Riders on a towed attachment are subject to injury, such as being struck by objects and being thrown off the attachment during sudden starts, stops and turns.

Riders obstruct the operator's view, resulting in the attachment being used in an unsafe manner.

Keep riders off of hitch bracket.

### Avoid Injury From Drawbar

Before you disconnect an attachment from machine hitch plate:

- Unload attachment.
- Stop attachment on level ground.
- Stop machine engine.
- Lock machine park brake.
- Block attachment wheels.
- Make sure hands, feet or other body parts are not under drawbar.

---

---

## Assembly

### Tools Required

#### Tools required for assembly:

- 1/2 in. wrench (1)
- 9/16 in. wrench (2)
- Pliers
- Flat blade screwdriver

# ASSEMBLY

## Parts in Kit

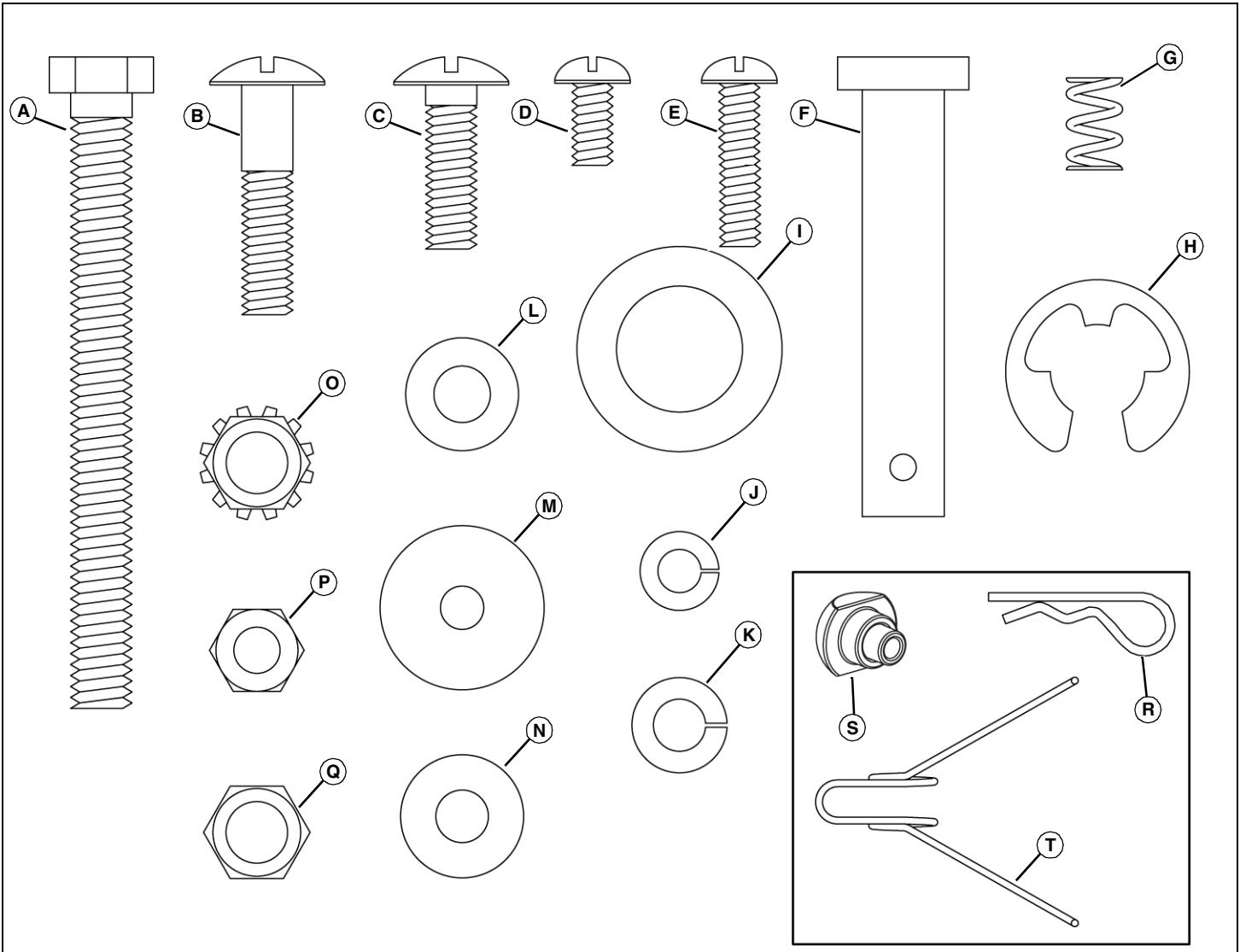

MX7745

Picture Note: Parts shown full size except items in box.

Qty.	Description	Qty.	Description
1	Hex Head Bolt, 3/8 x 3-3/4 (A)	12	Lockwasher, 5/16 (K)
2	Round Head Screw, 5/16 x 1-1/4 (B)	10	Flat Washer, 5/16 (L)
10	Round Head Screw, 5/16 x 1 (C)	2	Washer, Plastic (M)
2	Round Head Screw, 1/4 x 1/2 (D)	1	Washer, Steel (N)
1	Round Head Screw, 1/4 x 1 (E)	2	Keps Hex Nut, 3/8 (O)
1	Hitch Pin (F)	12	Hex Nut, 5/16 (P)
1	Helical Spring (G)	1	Locknut, 3/8 (Q)
1	Retaining Ring (H)	1	Cotter Pin (R)
2	Nylon Bushing (I)	2	Plastic Bearing (S)
4	Lockwasher, 1/4 (J)	1	Handle Spring (T)

# ASSEMBLY

## Parts in Kit (Not Shown)

Qty.	Description
1	Latch
1	Cart Bed
1	Lock Bracket
1	Axle
1	Axle Support
1	Towbar
1	Lock Bar
1	Pocket
2	Wheel Assembly
1	Clevis

## Assemble Cart

When assembling cart, do the following

- Do not discard cardboard bed divider, it can be used as a template for making dividers for the cart.
- Place pieces of carton under cart box to help avoid scratching finish.
- Put all bolt heads to the inside of the cart box.

## Install Axle Support

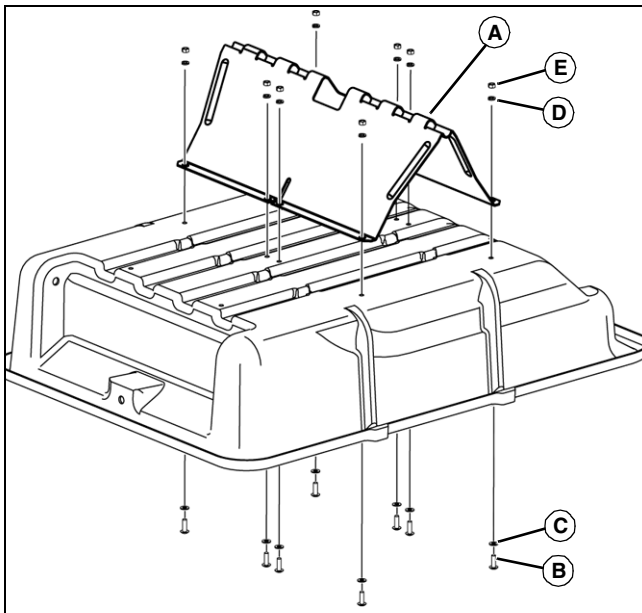

MX27806

1. Place axle support (A) on bottom of cart bed.
2. Install eight 5/16 x 1 round head screws (B) and eight 5/16 flat washers (C), from inside bed through axle support. Place eight 5/16 lockwashers (D) and eight 5/16 nuts (E) on bolts.
3. Tighten hardware.

## Install Lock Bracket

**NOTE:** Make sure notch on lock bracket is facing to the front of the cart.

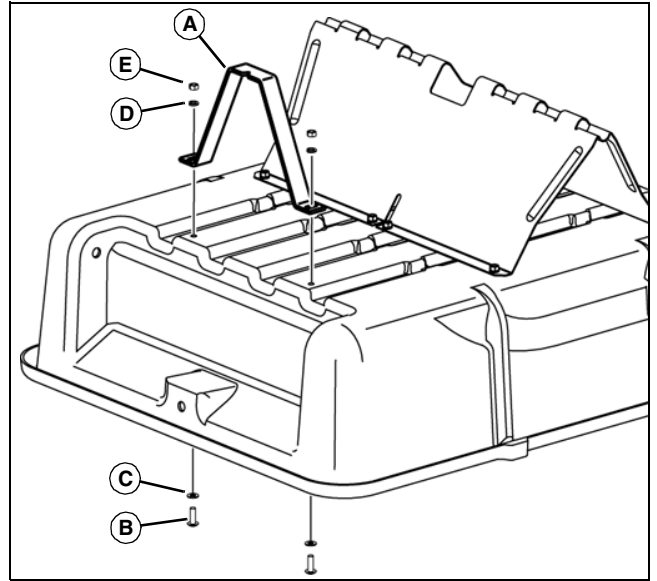

MX27807

1. Place lock bracket (A) on cart.
2. Install two 5/16 x 1 round head screws (B) and two 5/16 flat washers (C) from inside bed and through lock bracket.
3. Secure with two 5/16 lockwashers (D) and two 5/16 nuts (E).
4. Tighten hardware.

## Assemble Cart Lock Bar

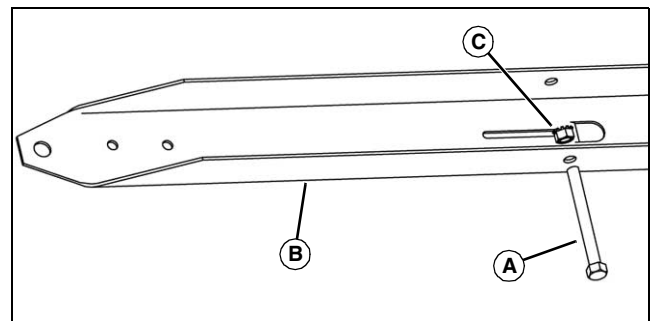

MX27809

1. Insert 3/8 x 3-3/4 hex head bolt (A) into drawbar (B) until end is even with edge of slot.
2. Thread one 3/8 Keps hex nut (C) (with teeth directed toward center of drawbar) onto bolt.

# ASSEMBLY

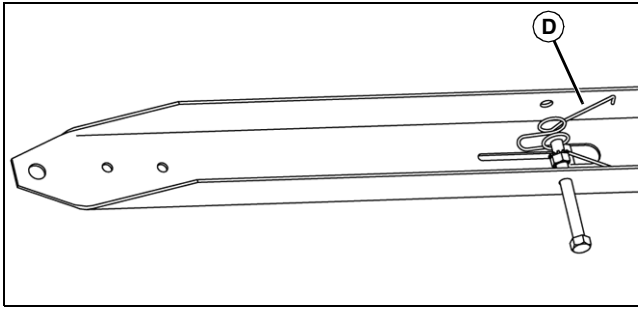

MX27811

3. Note orientation of spring (D) and slide partially over bolt and Keps nut. Place spring ears on inside of drawbar as shown to relieve tension and make installation easier.

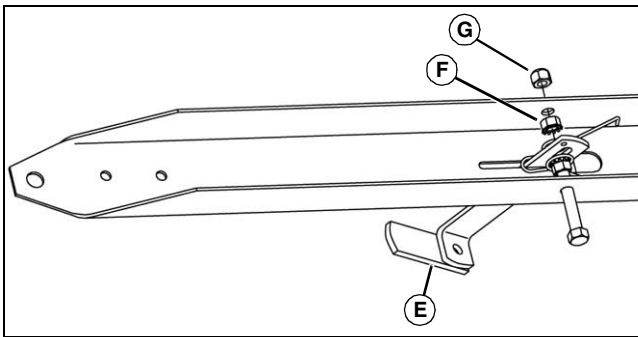

MX27812

4. Install lock bar (E) between spring and over bolt. Lock bar must be positioned with tab toward front of drawbar.
5. Install second Keps nut (F) onto bolt with teeth of Keps nut directed toward center of drawbar as shown. Adjust Keps nut until bolt is completely through drawbar and lock bar is centered in slot.
6. Install 3/8 locknut (G) on outside of drawbar leaving bolt snug, but able to rotate.
7. Tighten Keps nuts so that lock bar is centered in drawbar slot.

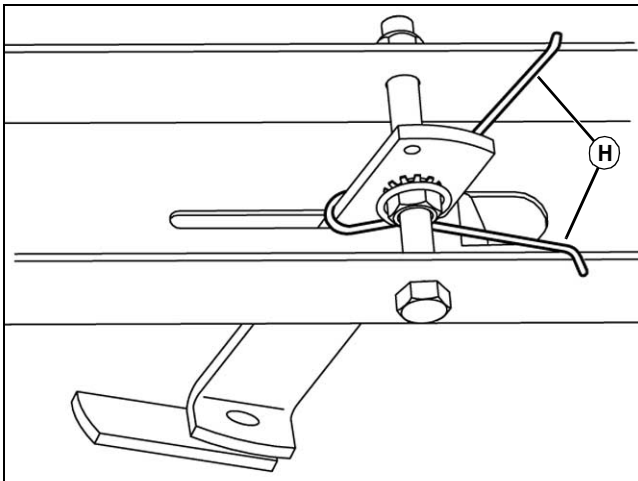

MX27808

8. Pull spring ears (H) out from inside of drawbar and hook over edge as shown.

## Install Clevis

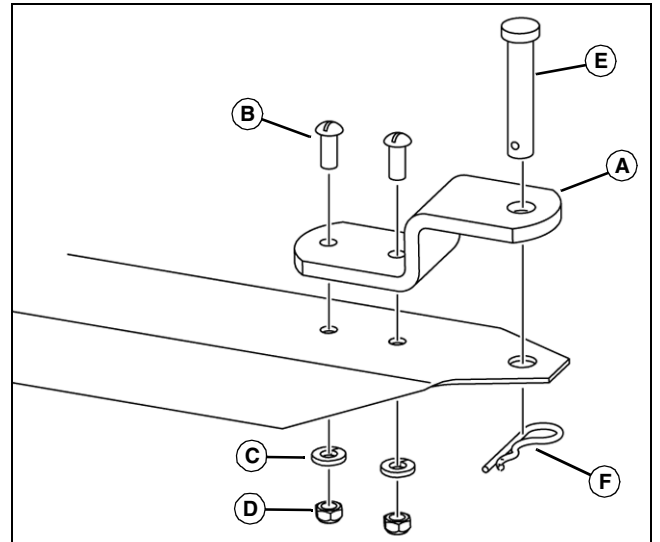

MX27810

1. Install clevis (A) on drawbar with two 5/16 x 1-1/4 round head screws (B), 5/16 lockwashers (C), and 5/16 nuts (D). Tighten hardware.
2. Install hitch pin (E) and cotter pin (F).

## Install Cart Drawbar and Wheels

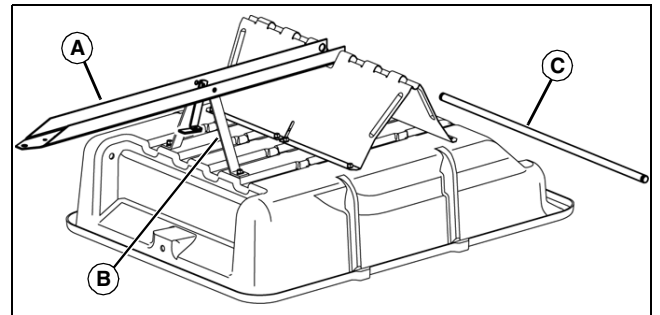

MX27817

1. Install drawbar assembly (A) lock bracket (B).

**NOTE: A light coating of grease or oil on axle will aid in inserting the axle through the axle support.**

2. Slide axle (C) through axle support and drawbar.
3. Ensure that lock bracket engages lock bar. Adjustment can be made by loosening the two screws securing lock bracket and moving lock bracket forward or back to change engagement and/or ease operation.

# INSTALLING

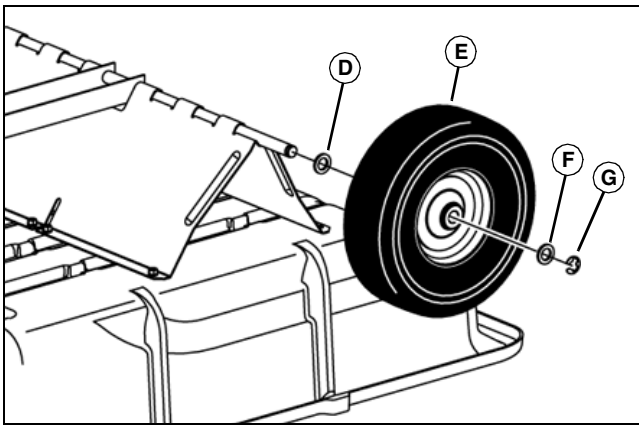

MX27813

- Slide nylon bushing (D) on one end of axle.
- Slide wheel (E), with valve stem to outside, on axle.
- Slide on second nylon bushing (F).
- Use pliers to install retaining ring (G) into groove on axle.
- Repeat to install remaining wheel on other end of axle.
- Inflate tires to correct tire pressure.

## Install Pocket Assembly

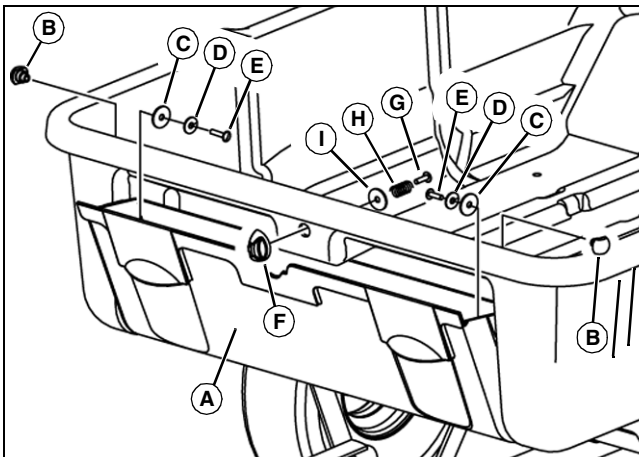

MX27814

- Insert pocket (A) into place as shown.
- Insert plastic bearing (B) at each end of pocket through bed and pocket.
- Secure each plastic bearing with one plastic washer (C), 1/4 lockwasher (D), and 1/4 x 1/2 round head screw (E).
- Install latch (F) with one 1/4 x 1 round head screw (G), helical spring (H), and steel washer (I).

## Installing

### Installing Cart



**CAUTION: Avoid injury! Before installing cart, make sure lock lever is locked in place.**

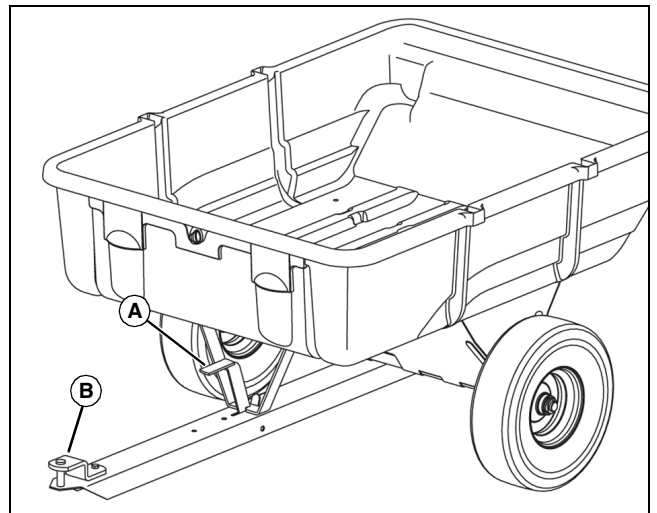

MX27744

- Lock cart lock bar (A) in place.
- Park machine safely. (See Parking Safely in the Safety section in the machine operator's manual.)
- Align cart drawbar with machine drawbar.
- Install hitch pin (B) through cart drawbar and machine drawbar. Secure hitch pin with hair cotter pin.

## Removing

### Removing Cart

- Park machine safely. (See Parking Safely in the Safety section in the machine operator's manual.)
- Unload cart.



**CAUTION: Avoid injury! Keep hands, feet and other body parts away from under drawbar.**

- Remove hair cotter pin and hitch pin.
- Push cart away from machine. Block cart wheels.
- Install pins in cart drawbar for storage.

# OPERATING

## Operating

### Determining Weight for Cart

**CAUTION: Avoid injury! Excessive towed load can cause loss of traction and loss of control on slopes. Stopping distance increases with speed and weight of towed load.**  
Total towed weight must not exceed combined weight of pulling machine, operator and front ballast, or the maximum capacity of the cart.

The following maximum loaded cart weight capacities are the average weight of each cart model loaded with dry sand leveled with the top of the cart.

Model Cart	Loaded Weight Capacity
7P	226 kg (500 lb)

**CAUTION: Avoid injury! If additional weight is required when towing a cart, add weight at or forward of the rear wheels. Adding weight behind the rear wheels can affect machine steering.**

Towing cart capacity will vary with weight of towing machine and operator. Add the weight of your machine to operator weight to find the maximum capacity of the towing cart.

With all cart usage, the cart load should be reduced when operating on slopes or slippery surfaces to maintain stability.

#### Example:

If Towing Machine Weighs:	225kg (500 lb)
Add Your Weight:	90kg (200 lb)
Combined Weight Equals	315kg (700 lb)

To maintain stability using the cart in this example, you cannot safely carry more than 315 kg (700 lb) without first adding additional ballast to the towing machine.

### Using Cart Pocket

**CAUTION: Avoid injury! The cart pocket is not designed to support operator weight. Do not attempt to use the cart pocket as a step.**

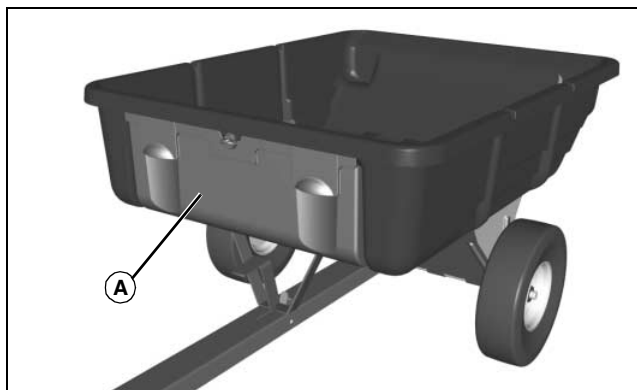

MX27746

Use the pocket (A) on the front of the cart to store gloves or tools you may need while using the cart.

Check to be sure the pocket is latched in the closed position before dumping the cart to avoid objects falling out.

### Unloading Cart

1. Park machine safely. (See Parking Safely in the Safety section in the machine operator's manual.)

**CAUTION: Avoid injury! Before dumping cart:**

- Park machine safely.
- Before backing up, make sure area is clear of bystanders, especially children.
- Make sure cart is installed to the towing machine.
- Evenly distribute load before releasing lock bar.
- Ensure operator is a safe distance when dumping cart! The lock bar to release the bed has the potential to release quickly.

2. Move cart lock bar forward to release cart box.
3. Tilt cart box back to unload cart.
4. Push cart down and move cart lock bar toward cart and lock into place.

## Service

### General Maintenance

**NOTE: Unload cart before performing any maintenance or service.**

- Wash cart bed after each use to avoid damage to bed or hardware.
- Check tire pressure with an accurate gauge, add or remove air if necessary.

## Specifications

### Model 7P Cart

Maximum Towing Speed	13 kph (8 mph)
Bed Capacity (Heaped)	20 m <sup>3</sup> (7 cu ft)
Maximum Load	226 kg (500 lb)
Maximum Tongue Weight	45 kg (100 lb)
Empty Weight	21 kg (65 lb)



# GETTING QUALITY SERVICE

---

---

## Tires

Size ..... 12x4-6

Inflation Pressure ..... 207 kPa (30 psi)

---

---

## Getting Quality Service

### John Deere Quality Continues with Quality Service

John Deere provides a process to handle your questions or problems, should they arise, to ensure that product quality continues with quality parts and service support.

Follow the steps below to get answers to any questions you may have about your product.

1. Refer to your attachment and machine operator manuals.
2. In North America or Canada, call John Deere Special Services at 1-866-218-8622 and provide product serial number (if available) and model number.

