

GL^{OW}PEAR[®]



GLOWPEAR MINI BENCH



KEY FEATURES INCLUDE

- **Engineered for edibles:** Designed for growing a wide range of fruits, vegetables, herbs, and flowers
- **Self watering:** Glowpear's set and forget integrated self watering technology to help plants thrive
- **Contemporary design aesthetic:** Designed for contemporary urban spaces
- **Tough and resilient:** UV resistant, durable polymer body with double-walled construction for insulation against hot and cold weather
- **Portability:** Conveniently compact, lightweight and versatile, the Mini is highly portable
- **Irrigation flexibility:** Option to water directly into the reservoir via the easy access fill point; via an automated irrigation system; or, directly into the soil
- **Real-time feedback:** Integrated water level indicator to provide real-time water level feedback
- **Modularity:** Easily add and interconnect additional modules to expand your garden
- **Surface Protection:** Built-in drip tray ensures indoor or outdoor surface protection

USER CONTEXTS

- Perfect for kitchen benches, window sills and small spaces, indoors and out
- Suitable for home or commercial environments
- A range of applications within balconies, courtyards, and apartments
- Broad appeal to young professionals, families, empty nesters, and design conscious consumers
- Ideal tool for teaching urban farming within schools, care facilities and family contexts

CONSTRUCTION MATERIALS

- Injection molded HDPE planter
- Glass filled HDPE legs
- 100% Recyclable materials
- Food safe, BPA free

TECHNICAL SPECIFICATIONS

Assembled Size	23.6" x 9.8" x 11.8" (600mm x 250mm x 300mm)
Packaged Size	24.8" x 11.0" x 10.2" (630mm x 280mm x 260mm)
Packaged Weight	9.9lbs (4.5kg)
Shipping volume (Cube)	1.625 cu.ft (0.046 cu.m)
Growing volume (Soil Capacity)	4.5 Gal (17.0L)
Water Reservoir	1.2 Gal (4.5L)

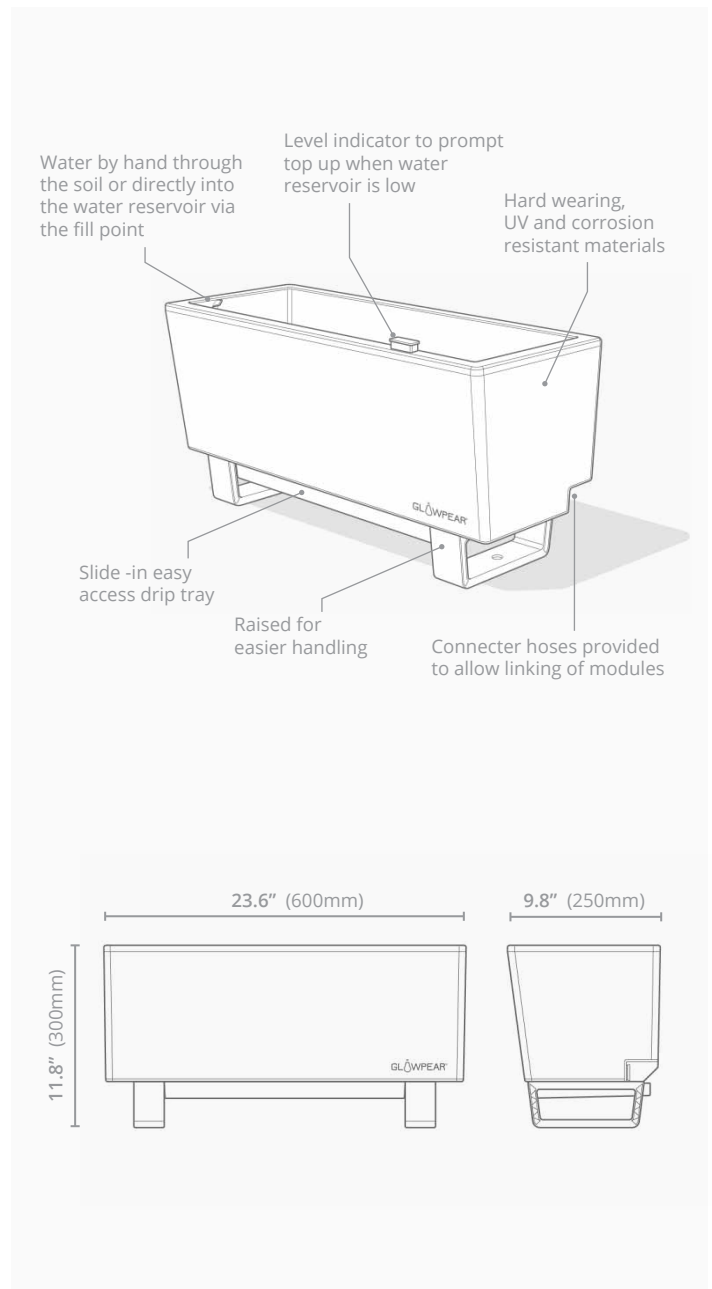

CONTACT DETAILS

Glowpear sales & distribution:
Joel Anderson
Commercial Director
P +61 422 713 193
E joel@glowpear.com.au

KEY FEATURES INCLUDE

- **Engineered for edibles:** Designed for growing a wide range of fruits, vegetables, herbs, and flowers
- **Self watering:** Glowpear's set and forget integrated self watering technology to help plants thrive
- **Contemporary design aesthetic:** Designed for contemporary urban spaces
- **Tough and resilient:** UV resistant, durable polymer body with double-walled construction for insulation against hot and cold weather
- **Portability:** Conveniently compact, lightweight and versatile, the Mini is highly portable
- **Irrigation flexibility:** Option to water directly into the reservoir via the easy access fill point; via an automated irrigation system; or, directly into the soil
- **Real-time feedback:** Integrated water level indicator to provide real-time water level feedback
- **Modularity:** Easily add and interconnect additional modules to expand your garden

USER CONTEXTS

- Specifically designed for wall mounting to create vertical gardens
- Suitable for home or commercial environments
- A range of applications within balconies, courtyards, and apartments
- Broad appeal to young professionals, families, empty nesters, and design conscious consumers
- Ideal tool for teaching urban farming within schools, care facilities and family contexts

CONSTRUCTION MATERIALS

- Injection molded HDPE planter
- Glass filled HDPE brackets
- 100% Recyclable materials
- Food safe, BPA free

TECHNICAL SPECIFICATIONS

Assembled Size	23.6" x 10.1" x 8.8" (600mm x 257mm x 225mm)
Packaged Size	24.8" x 11.0" x 10.2" (630mm x 280mm x 260mm)
Packaged Weight	9.0lbs (4.1kg)
Shipping volume (Cube)	1.625 cu.ft (0.046 cu.m)
Growing volume (Soil Capacity)	4.5 Gal (17.0L)
Water Reservoir	1.2 Gal (4.5L)

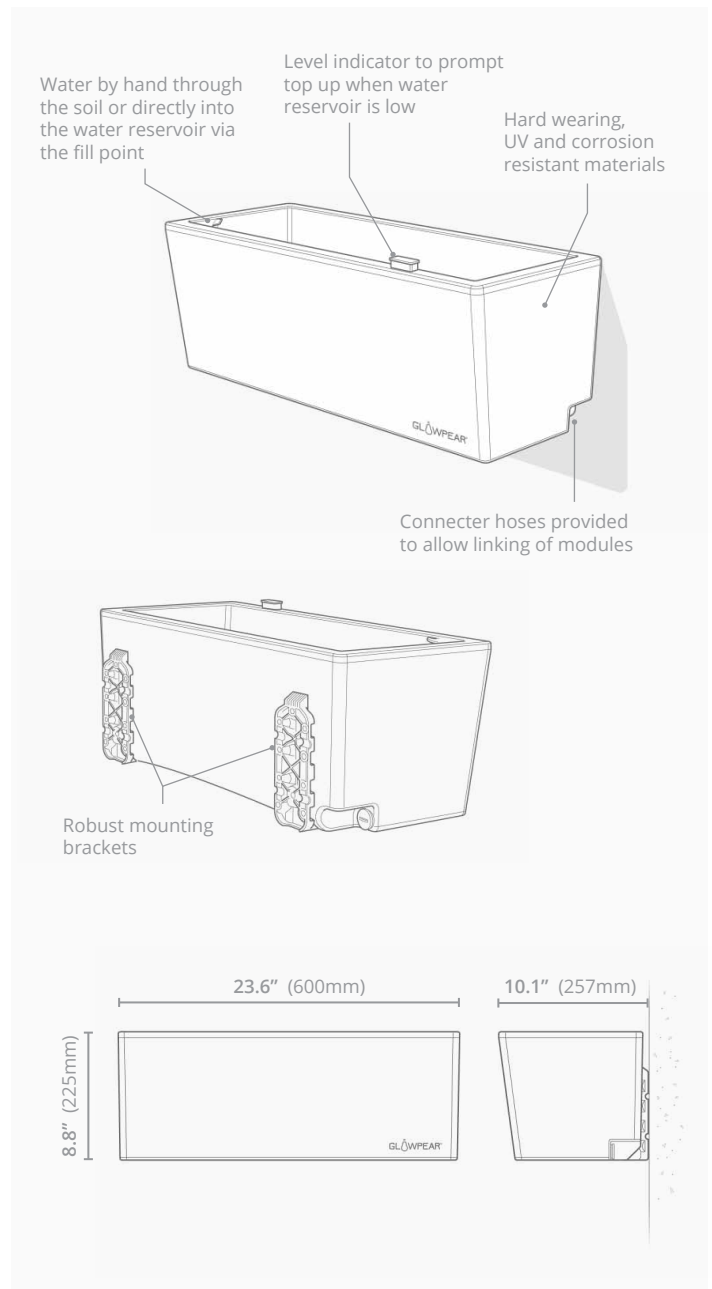

CONTACT DETAILS

Glowpear sales & distribution:

Joel Anderson
Commercial Director
P +61 422 713 193
E joel@glowpear.com.au

KEY FEATURES INCLUDE

- **Engineered for edibles:** Designed for growing a wide range of fruits, vegetables, herbs, and flowers
- **Self watering:** Glowpear's set and forget integrated self watering technology to help plants thrive
- **Contemporary design aesthetic:** Designed for contemporary urban spaces
- **Tough and resilient:** UV resistant, durable polymer body with double-walled construction for insulation against hot and cold weather
- **Portability:** Conveniently compact, lightweight and versatile, the Mini is highly portable
- **Irrigation flexibility:** Option to water directly into the reservoir via the easy access fill point; via an automated irrigation system; or, directly into the soil
- **Real-time feedback:** Integrated water level indicator to provide real-time water level feedback
- **Modularity:** Easily add and interconnect additional modules to expand your garden

USER CONTEXTS

- Specifically designed for balustrade and hand rail mounting
- Suitable for home or commercial environments
- A range of applications within balconies, courtyards, and apartments
- Broad appeal to young professionals, families, empty nesters, and design conscious consumers
- Ideal tool for teaching urban farming within schools, care facilities and family contexts

CONSTRUCTION MATERIALS

- Injection molded HDPE planter
- Glass filled HDPE brackets
- 100% Recyclable materials
- Food safe, BPA free

TECHNICAL SPECIFICATIONS

Assembled Size	23.6" x 14.6" max. x 8.8" (600mm x 372mm max. x 225mm)
Packaged Size	24.8" x 11.0" x 10.2" (630mm x 280mm x 260mm)
Packaged Weight	9.9lbs (4.5kg)
Shipping volume (Cube)	1.625 cu.ft (0.046 cu.m)
Growing volume (Soil Capacity)	4.5 Gal (17.0L)
Water Reservoir	1.2 Gal (4.5L)

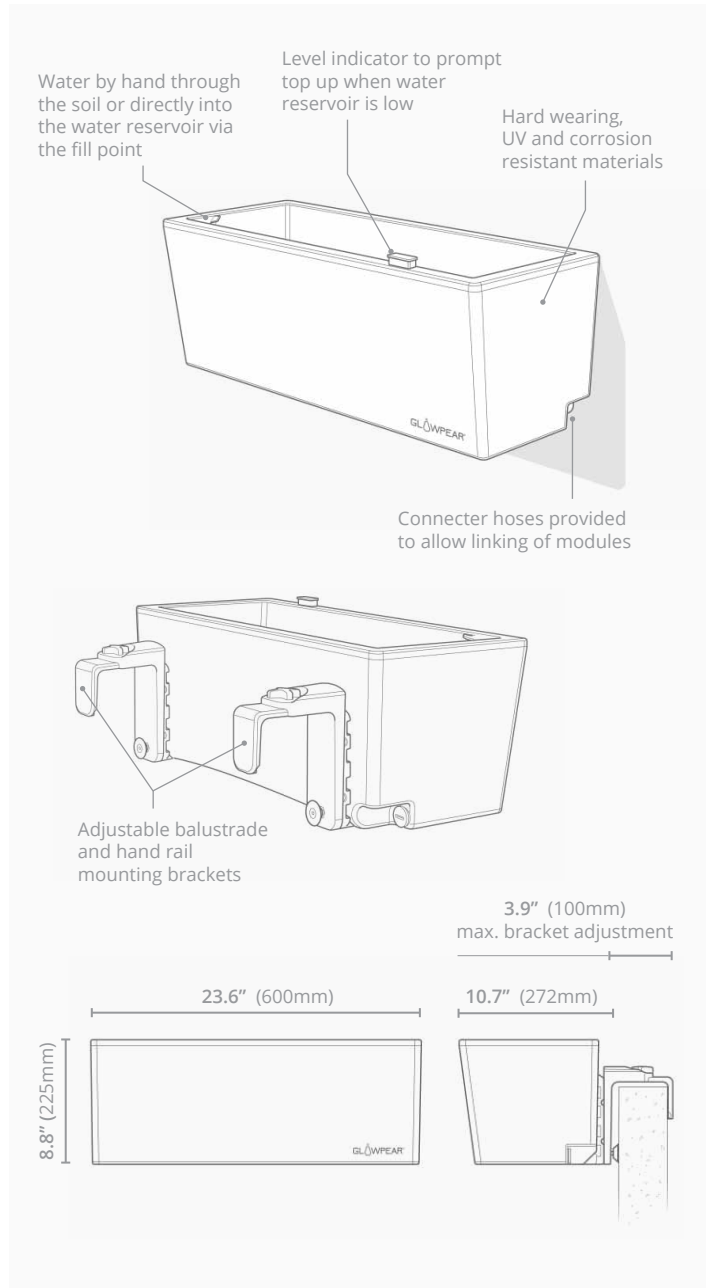

CONTACT DETAILS

Glowpear sales & distribution:
Joel Anderson
 Commercial Director
 P +61 422 713 193
 E joel@glowpear.com.au