

# OPERATOR'S MANUAL

## 13 in. THICKNESS PLANER R4330

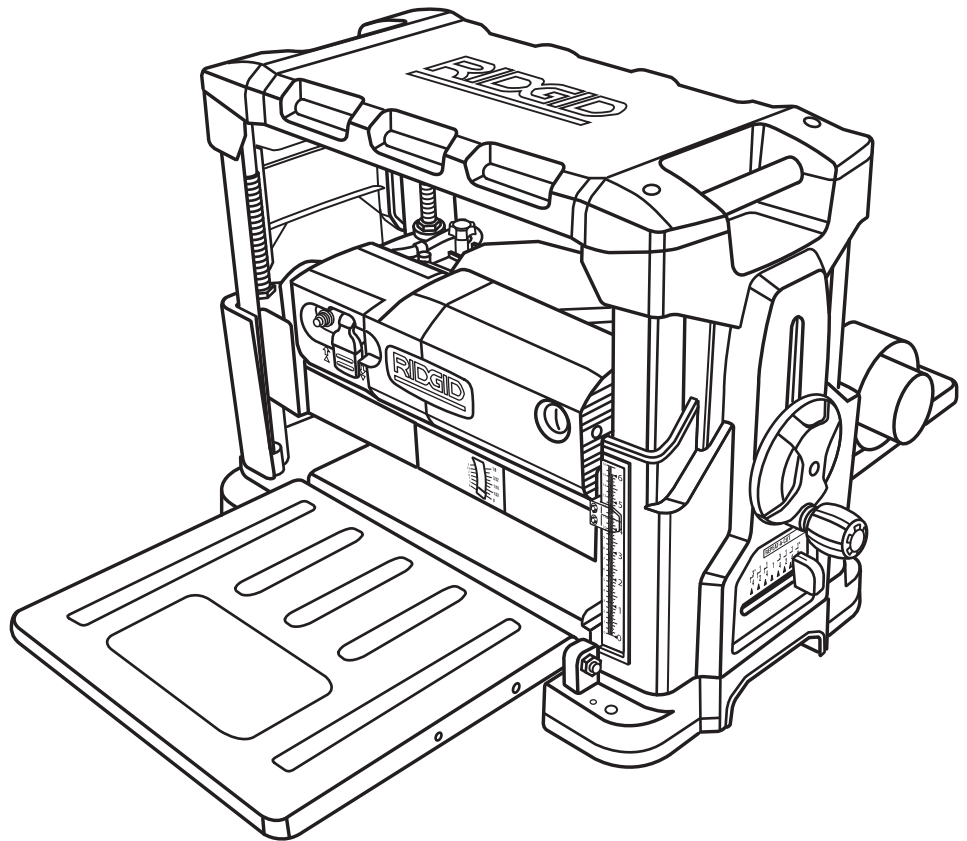

Your new planer has been engineered and manufactured to our high standards for dependability, ease of operation, and operator safety. When properly cared for, it will give you years of rugged, trouble-free performance.

**⚠ WARNING:**

To reduce the risk of injury, the user must read and understand the operator's manual before using this product.

Thank you for buying a RIDGID® product.

**SAVE THIS MANUAL FOR FUTURE REFERENCE**

# TABLE OF CONTENTS

---

■ Introduction.....	2
■ General Safety Rules .....	3-4
■ Specific Safety Rules.....	4-5
■ Symbols.....	6-7
■ Electrical .....	8-9
■ Glossary of Terms.....	10
■ Features .....	11-12
■ Tools Needed.....	12
■ Loose Parts.....	13
■ Assembly .....	14-16
■ Operation .....	17-20
■ Adjustments.....	21-22
■ Maintenance .....	23-25
■ Troubleshooting .....	26
■ Warranty .....	27
■ Parts Ordering/Service .....	Back page

## INTRODUCTION

---

This tool has many features for making its use more pleasant and enjoyable. Safety, performance, and dependability have been given top priority in the design of this product making it easy to maintain and operate.

# GENERAL SAFETY RULES

---

## **WARNING:**

**Read and understand all instructions.** Failure to follow all instructions listed below, may result in electric shock, fire and/or serious personal injury.

---

## **READ ALL INSTRUCTIONS**

- **KNOW YOUR POWER TOOL.** Read the operator's manual carefully. Learn the tool's applications and limitations as well as the specific potential hazards related to this tool.
- **GUARD AGAINST ELECTRICAL SHOCK BY PREVENTING BODY CONTACT WITH GROUNDED SURFACES.** For example: pipes, radiators, ranges, refrigerator enclosures.
- **KEEP GUARDS IN PLACE** and in good working order.
- **REMOVE ADJUSTING KEYS AND WRENCHES.** Form habit of checking to see that keys and adjusting wrenches are removed from tool before turning it on.
- **KEEP WORK AREA CLEAN.** Cluttered areas and benches invite accidents. **DO NOT** leave tools or pieces of wood on the tool while it is in operation.
- **DO NOT USE IN DANGEROUS ENVIRONMENTS.** Do not use power tools in damp or wet locations or expose to rain. Keep the work area well lit.
- **KEEP CHILDREN AND VISITORS AWAY.** All visitors should wear safety glasses and be kept a safe distance from work area. Do not let visitors contact tool or extension cord while operating.
- **MAKE WORKSHOP CHILDPROOF** with padlocks and master switches, or by removing starter keys.
- **DON'T FORCE TOOL.** It will do the job better and safer at the feed rate for which it was designed.
- **USE RIGHT TOOL.** Don't force the tool or attachment to do a job it was not designed for. Don't use it for a purpose not intended.
- **USE THE PROPER EXTENSION CORD.** Make sure your extension cord is in good condition. Use only a cord heavy enough to carry the current your product will draw. An undersized cord will cause a drop in line voltage resulting in loss of power and overheating. A wire gauge size (A.W.G.) of at least **12** is recommended for an extension cord 50 feet or less in length. If in doubt, use the next heavier gauge. The smaller the gauge number, the heavier the cord.
- **DRESS PROPERLY.** Do not wear loose clothing, gloves, neckties, or jewelry. They can get caught and draw you into moving parts. Rubber gloves and nonskid footwear are recommended when working outdoors. Also wear protective hair covering to contain long hair.
- **ALWAYS WEAR SAFETY GLASSES WITH SIDE SHIELDS.** Everyday eyeglasses have only impact-resistant lenses, they are **NOT** safety glasses.
- **SECURE WORK.** Use clamps or a vise to hold work when practical. It's safer than using your hand and frees both hands to operate tool.
- **DON'T OVERREACH.** Keep proper footing and balance at all times.
- **MAINTAIN TOOLS WITH CARE.** Keep tools sharp and clean for better and safer performance. Follow instructions for lubricating and changing accessories.
- **DISCONNECT TOOLS.** When not in use, before servicing, or when changing attachments, blades, bits, cutters, etc., all tools should be disconnected.
- **AVOID ACCIDENTAL STARTING.** Be sure switch is off when plugging in any tool.
- **USE RECOMMENDED ACCESSORIES.** Consult the operator's manual for recommended accessories. The use of improper accessories may risk injury.
- **NEVER STAND ON TOOL.** Serious injury could occur if the tool is tipped or if the cutting tool is unintentionally contacted.
- **CHECK DAMAGED PARTS.** Before further use of the tool, a guard or other part that is damaged should be carefully checked to determine that it will operate properly and perform its intended function. Check for alignment of moving parts, binding of moving parts, breakage of parts, mounting and any other conditions that may affect its operation. A guard or other part that is damaged must be properly repaired or replaced by an authorized service center to avoid risk of personal injury.
- **USE THE RIGHT DIRECTION OF FEED.** Feed work into a blade or cutter against the direction of rotation of blade or cutter only.
- **NEVER LEAVE TOOL RUNNING UNATTENDED. TURN THE POWER OFF.** Don't leave tool until it comes to a complete stop.
- **PROTECT YOUR LUNGS.** Wear a face or dust mask if the cutting operation is dusty.
- **PROTECT YOUR HEARING.** Wear hearing protection during extended periods of operation.
- **DO NOT ABUSE CORD.** Never yank cord to disconnect from receptacle. Keep cord from heat, oil, and sharp edges.
- **USE OUTDOOR EXTENSION CORDS.** When tool is used outdoors, use only extension cords with approved ground connection that are intended for use outdoors and so marked.
- **NEVER USE IN AN EXPLOSIVE ATMOSPHERE.** Normal sparking of the motor could ignite fumes.

# GENERAL SAFETY RULES

---

- **INSPECT TOOL CORDS PERIODICALLY.** If damaged, have repaired by a qualified service technician at an authorized service facility. The conductor with insulation having an outer surface that is green with or without yellow stripes is the equipment-grounding conductor. If repair or replacement of the electric cord or plug is necessary, do not connect the equipment-grounding conductor to a live terminal. Repair or replace a damaged or worn cord immediately. Stay constantly aware of cord location and keep it well away from the rotating blade.
- **INSPECT EXTENSION CORDS PERIODICALLY** and replace if damaged.
- **GROUND ALL TOOLS.** If tool is equipped with three-prong plug, it should be plugged into a three-hole electrical receptacle.
- **CHECK WITH A QUALIFIED ELECTRICIAN** or service personnel if the grounding instructions are not completely understood or if in doubt as to whether the tool is properly grounded.
- **USE ONLY CORRECT ELECTRICAL DEVICES:** 3-wire extension cords that have 3-prong grounding plugs and 3-pole receptacles that accept the tool's plug.
- **DO NOT MODIFY** the plug provided. If it will not fit the outlet, have the proper outlet installed by a qualified electrician.
- **KEEP TOOL DRY, CLEAN, AND FREE FROM OIL AND GREASE.** Always use a clean cloth when cleaning. Never use brake fluids, gasoline, petroleum-based products, or any solvents to clean tool.
- **STAY ALERT AND EXERCISE CONTROL.** Watch what you are doing and use common sense. Do not operate tool when you are tired. Do not rush.
- **DO NOT USE TOOL IF SWITCH DOES NOT TURN IT ON AND OFF.** Have defective switches replaced by an authorized service center.
- **NEVER TOUCH BLADE** or other moving parts during use.
- **NEVER START A TOOL WHEN ANY ROTATING COMPONENT IS IN CONTACT WITH THE WORKPIECE.**
- **DO NOT OPERATE A TOOL WHILE UNDER THE INFLUENCE OF DRUGS, ALCOHOL, OR ANY MEDICATION.**
- **WHEN SERVICING** use only identical replacement parts. Use of any other parts may create a hazard or cause product damage.
- **USE ONLY RECOMMENDED ACCESSORIES** listed in this manual or addendums. Use of accessories that are not listed may cause the risk of personal injury. Instructions for safe use of accessories are included with the accessory.
- **DOUBLE CHECK ALL SETUPS.** Make sure blade is tight and not making contact with tool or workpiece before connecting to power supply.

# SPECIFIC SAFETY RULES

---

- **NEVER PERFORM THE PLANING OPERATION** with the cutterhead or dust hood removed.
- **NEVER MAKE A PLANING CUT** deeper than 1/8 in.
- **DO NOT PLANE MATERIAL** shorter than 14 in. or narrower than 3/4 in.
- **MAINTAIN THE PROPER RELATIONSHIP** between the infeed and outfeed surfaces and the cutterhead blade path.
- **SUPPORT THE WORKPIECE ADEQUATELY** at all times during operation; maintain control of the work at all times.
- **NEVER FEED THE WORK** from the rear of the planer.
- **DO NOT ATTEMPT TO PERFORM** an abnormal or little used operation without the use of sturdy and adequate jigs, fixtures, stops, and the like.
- **NEVER** plane more than one piece at a time. **DO NOT PLANE** more than one workpiece on the planer table at a time.
- **BEFORE STARTING UP,** recheck to make certain all holding screws are tight.
- **STOP THE MACHINE** and recheck the hex head bolts and blades for tightness after about 50 hours of operation.
- **DO NOT FORCE FEED THE WORKPIECE** through the machine. Let the planer apply the proper feed rate.
- **CHECK THE FEED ROLLERS** occasionally to be sure there are no chips or sawdust between any components.
- **PLANE ONLY SOUND LUMBER;** there should be no loose knots and as few tight knots as possible. Make sure the workpiece is free from nails, screws, stones, or other foreign objects that could break or chip the blades.
- **NEVER STAND DIRECTLY IN LINE** with either the infeed or outfeed sides. Stand off to one side.
- **MAKE SURE THE BLADES ARE ATTACHED** as described in the operation section. The blades are sharp and can easily cut your hand. Use caution in handling the blades and cutterhead guard.

# SPECIFIC SAFETY RULES

---

- **NEVER PUT YOUR FINGERS** into the dust hood or under the cutter guard.
- **ALLOW THE CUTTERHEAD** to reach full speed before using the planer.
- **REPLACEMENT PARTS.** All repairs, whether electrical or mechanical, should be made at your nearest authorized service center.
- **DO NOT** attempt to turn cutterhead with hands.
- **IF ANY PART OF THIS TOOL IS MISSING** or should break, bend, or fail in any way, or should any electrical component fail to perform properly, shut off the power switch, remove the plug from the power source, and have damaged, missing, or failed parts replaced before resuming operation.
- **ALWAYS STAY ALERT!** Do not allow familiarity (gained from frequent use of your planer) to cause a careless mistake. **ALWAYS REMEMBER** that a careless fraction of a second is sufficient to inflict serious injury.
- **MAKE SURE THE WORK AREA HAS AMPLE LIGHTING** to see the work and that no obstructions will interfere with safe operation **BEFORE** performing any work using your planer.
- **ALWAYS TURN OFF TOOL** before disconnecting it to avoid accidental starting when reconnecting to power supply.
- **IF THE POWER SUPPLY CORD IS DAMAGED**, it must be replaced only by the manufacturer or by an authorized service center to avoid risk.
- **THIS TOOL** should have the following markings:
  - a) Wear eye protection.
  - b) Keep hands away from cutterhead.
  - c) Do not operate saw without guards in place.
  - d) Do not perform any operation freehand.
  - e) Never reach around saw blade.
  - f) Turn off tool and wait for blades to stop before moving workpiece or changing settings.
  - g) Disconnect power (or unplug tool as applicable) before changing blades or servicing.
  - h) No load speed.
- **SAVE THESE INSTRUCTIONS.** Refer to them frequently and use to instruct other users. If you loan someone this tool, loan them these instructions also.

---

## **WARNING:**

Some dust created by power sanding, sawing, grinding, drilling, and other construction activities contains chemicals known to cause cancer, birth defects or other reproductive harm. Some examples of these chemicals are:







- lead from lead-based paints,
- crystalline silica from bricks and cement and other masonry products, and
- arsenic and chromium from chemically-treated lumber.

Your risk from these exposures varies, depending on how often you do this type of work. To reduce your exposure to these chemicals: work in a well ventilated area, and work with approved safety equipment, such as those dust masks that are specially designed to filter out microscopic particles.

---

# SYMBOLS



Some of the following symbols may be used on this tool. Please study them and learn their meaning. Proper interpretation of these symbols will allow you to operate the tool better and safer.

SYMBOL	NAME	DESIGNATION/EXPLANATION
V	Volts	Voltage
A	Amperes	Current
Hz	Hertz	Frequency (cycles per second)
W	Watt	Power
min	Minutes	Time
~	Alternating Current	Type of current
==	Direct Current	Type or a characteristic of current
$n_0$	No Load Speed	Rotational speed, at no load
	Class II Construction	Double-insulated construction
.../min	Per Minute	Revolutions, strokes, surface speed, orbits etc., per minute
	Wet Conditions Alert	Do not expose to rain or use in damp locations.
	Read The Operator's Manual	To reduce the risk of injury, user must read and understand operator's manual before using this product.
	Eye Protection	Always wear safety goggles, safety glasses with side shields, or a full face shield when operating this product.
	Safety Alert	Precautions that involve your safety.
	No Hands Symbol	Failure to keep your hands away from the blade will result in serious personal injury.
	Hot Surface	To reduce the risk of injury or damage, avoid contact with any hot surface.

# SYMBOLS

---

The following signal words and meanings are intended to explain the levels of risk associated with this product.

SYMBOL	SIGNAL	MEANING
	<b>DANGER:</b>	Indicates an imminently hazardous situation, which, if not avoided, will result in death or serious injury.
	<b>WARNING:</b>	Indicates a potentially hazardous situation, which, if not avoided, could result in death or serious injury.
	<b>CAUTION:</b>	Indicates a potentially hazardous situation, which, if not avoided, may result in minor or moderate injury.
	<b>CAUTION:</b>	(Without Safety Alert Symbol) Indicates a situation that may result in property damage.

## SERVICE

Servicing requires extreme care and knowledge and should be performed only by a qualified service technician. For service we suggest you return the product to your nearest **AUTHORIZED SERVICE CENTER** for repair. When servicing, use only identical replacement parts.



### **WARNING:**

To avoid serious personal injury, do not attempt to use this product until you read thoroughly and understand completely the operator's manual. If you do not understand the warnings and instructions in the operator's manual, do not use this product. Call RIDGID® customer service for assistance.

---

---

### **WARNING:**



The operation of any power tool can result in foreign objects being thrown into your eyes, which can result in severe eye damage. Before beginning power tool operation, always wear safety goggles or safety glasses with side shields and, when needed, a full face shield. We recommend Wide Vision Safety Mask for use over eyeglasses or standard safety glasses with side shields. Always use eye protection which is marked to comply with ANSI Z87.1.

---

## SAVE THESE INSTRUCTIONS



# ELECTRICAL

## EXTENSION CORDS

Use only 3-wire extension cords that have 3-prong grounding plugs and 3-pole receptacles that accept the tool's plug. When using a power tool at a considerable distance from the power source, use an extension cord heavy enough to carry the current that the tool will draw. An undersized extension cord will cause a drop in line voltage, resulting in a loss of power and causing the motor to overheat. Use the chart provided below to determine the minimum wire size required in an extension cord. Only round jacketed cords listed by Underwriter's Laboratories (UL) should be used.

\*\*Ampere rating (on tool faceplate)

0-2.0    2.1-3.4    3.5-5.0    5.1-7.0    7.1-12.0    12.1-16.0

Cord Length	Wire Size (A.W.G.)					
25'	16	16	16	16	14	14
50'	16	16	16	14	14	12
100'	16	16	14	12	10	—

\*\*Used on 12 gauge - 20 amp circuit.

**NOTE:** AWG = American Wire Gauge

When working with the tool outdoors, use an extension cord that is designed for outside use. This is indicated by the letters "WA" on the cord's jacket.

Before using an extension cord, inspect it for loose or exposed wires and cut or worn insulation.

### **WARNING:**

Keep the extension cord clear of the working area. Position the cord so that it will not get caught on lumber, tools or other obstructions while you are working with a power tool. Failure to do so can result in serious personal injury.

### **WARNING:**

Check extension cords before each use. If damaged replace immediately. Never use tool with a damaged cord since touching the damaged area could cause electrical shock resulting in serious injury.

## ELECTRICAL CONNECTION

This tool is powered by a precision built electric motor. It should be connected to a **power supply that is 120 V, 60 Hz, AC only (normal household current)**. Do not operate this tool on direct current (DC). A substantial voltage drop will cause a loss of power and the motor will overheat. If the tool does not operate when plugged into an outlet, double check the power supply.

## SPEED AND WIRING

The no-load speed of this tool is approximately 10,000 RPM. This speed is not constant and decreases under a load or with lower voltage. For voltage, the wiring in a shop is as important as the motor's horsepower rating. A line intended only for lights cannot properly carry a power tool motor. Wire that is heavy enough for a short distance will be too light for a greater distance. A line that can support one power tool may not be able to support two or three tools.

## GROUNDING INSTRUCTIONS

In the event of a malfunction or breakdown, grounding provides a path of least resistance for electric current to reduce the risk of electric shock. This tool is equipped with an electric cord having an equipment-grounding conductor and a grounding plug. The plug must be plugged into a matching outlet that is properly installed and grounded in accordance with all local codes and ordinances.

Do not modify the plug provided. If it will not fit the outlet, have the proper outlet installed by a qualified electrician. Improper connection of the equipment-grounding conductor can result in a risk of electric shock. The conductor with insulation having an outer surface that is green with or without yellow stripes is the equipment-grounding conductor. If repair or replacement of the electric cord or plug is necessary, do not connect the equipment-grounding conductor to a live terminal.

Check with a qualified electrician or service personnel if the grounding instructions are not completely understood, or if in doubt as to whether the tool is properly grounded.

Repair or replace a damaged or worn cord immediately.

This tool is intended for use on a circuit that has an outlet like the one shown in figure 1. It also has a grounding pin like the one shown.

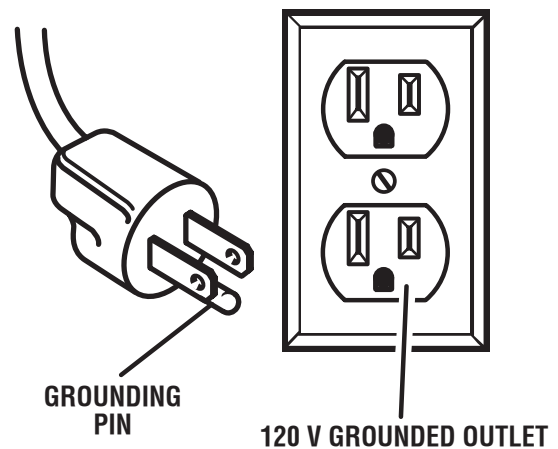

Fig. 1



# ELECTRICAL

## MOTOR SAFETY PROTECTION

This motor should be blown out or vacuumed frequently to prevent sawdust buildup which can interfere with normal motor ventilation.

- Connect this tool to a power source with the appropriate voltage for your model and a 15-amp branch circuit with a 15-amp time delay fuse or circuit breaker. Using the wrong size fuse can damage the motor.
- If the motor won't start, turn off the power switch immediately and unplug the tool. Check the cutterhead to make sure it turns freely. If the head is free, try to start the motor again. If the motor still does not start, refer to the *Troubleshooting* section.

Frequent "blowing" of fuses or tripping of circuit breakers may result if:

- Improper or dull blades are used.  
**NOTE:** Do not continuously use the thickness planer set at maximum depth of cut (1/8 in.) and at full 13 in. width of cut. Continuous use at maximum cutting capacity will damage your motor.
- Motor is overloaded. Overloading can occur if a workpiece is fed too rapidly or if the tool is misaligned.
- Motor circuit is fused differently from recommendations. Always follow instructions for the proper fuse / breaker. Do not use a fuse/breaker of greater capacity without consulting a qualified electrician.
- Low voltage. Although the motor is designed for operation on the voltage and frequency specified on the motor, normal loads will be handled safely on voltage no more than ten percent above or below that figure. Heavy loads, however, require that voltage at motor terminals equal the voltage specified on the motor.

**NOTE:** Always check the connections, the load, and the supply circuit whenever the motor fails to perform satisfactorily.

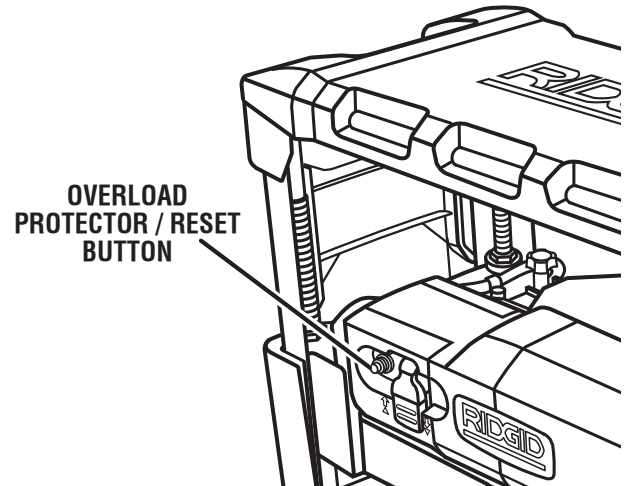

Fig. 2

## MOTOR OVERLOAD PROTECTOR

See Figure 2.

### **WARNING:**

To reduce the risk of serious personal injury from thrown objects or blade contact from unexpected starting, immediately turn off the tool if the protector stops the motor. Remove the switch key and allow the motor time to cool.

This planer is equipped with a overload protector device which will automatically "trip" and cause the planer to shut down if the motor is overheating due to continuous heavy cutting.

The planer overload protector can only be reset manually by the user after the planer has been allowed to adequately cool. Allow 15 - 30 minutes.

Should the overload protector "trip":

- Turn switch **OFF ( O )**.
- Raise carriage and remove board.
- After 15 - 30 minutes, reset the overload protector by pushing the red reset button on the front of the tool. An audible click will indicate the overload protector is reset. Once the button is reset, the tool may be started and operated as normal.

**NOTE:** If the red button won't click into place immediately, the motor is still too hot and must be allowed to cool.

- If motor has cooled, button will remain in.

# GLOSSARY OF TERMS

---

## **Anti-Kickback Pawls (radial arm and table saws)**

A device which, when properly installed and maintained, is designed to stop the workpiece from being kicked back toward the front of the saw during a ripping operation.

## **Arbor**

The shaft on which a blade or cutting tool is mounted.

## **Bevel Cut**

A cutting operation made with the blade at any angle other than 90° to the table surface.

## **Chamfer**

A cut removing a wedge from a block so the end (or part of the end) is angled rather than at 90°.

## **Compound Cut**

A cross cut made with both a miter and a bevel angle.

## **Cross Cut**

A cutting or shaping operation made across the grain or the width of the workpiece.

## **Cutterhead (planers and jointer planers)**

A rotating cutterhead with adjustable blades or knives. The blades or knives remove material from the workpiece.

## **Dado Cut**

A non-through cut which produces a square-sided notch or trough in the workpiece (requires a special blade).

## **Featherboard**

A device used to help control the workpiece by guiding it securely against the table or fence during any ripping operation.

## **FPM or SPM**

Feet per minute (or strokes per minute), used in reference to blade movement.

## **Freehand**

Performing a cut without the workpiece being guided by a fence, miter gauge, or other aids.

## **Gum**

A sticky, sap-based residue from wood products.

## **Heel**

Alignment of the blade to the fence.

## **Kerf**

The material removed by the blade in a through cut or the slot produced by the blade in a non-through or partial cut.

## **Kickback**

A hazard that can occur when the blade binds or stalls, throwing the workpiece back toward operator.

## **Leading End**

The end of the workpiece pushed into the tool first.

## **Miter Cut**

A cutting operation made with the workpiece at any angle to the blade other than 90°.

## **Non-Through Cuts**

Any cutting operation where the blade does not extend completely through the thickness of the workpiece.

## **Push Blocks (for jointer planers)**

Device used to feed the workpiece over the jointer planer cutterhead during any operation. This aid helps keep the operator's hands well away from the cutterhead.

## **Push Blocks and Push Sticks (for table saws)**

Devices used to feed the workpiece through the saw blade during cutting operations. A push stick (not a push block) should be used for narrow ripping operations. These aids help keep the operator's hands well away from the blade.

## **Pilot Hole (drill presses)**

A small hole drilled in a workpiece that serves as a guide for drilling large holes accurately.

## **Resaw**

A cutting operation to reduce the thickness of the workpiece to make thinner pieces.

## **Resin**

A sticky, sap-based substance that has hardened.

## **Revolutions Per Minute (RPM)**

The number of turns completed by a spinning object in one minute.

## **Ripping or Rip Cut**

A cutting operation along the length of the workpiece.

## **Riving Knife/Spreader/Splitter (table saws)**

A metal piece, slightly thinner than the blade, which helps keep the kerf open and also helps to prevent kickback.

## **Saw Blade Path**

The area over, under, behind, or in front of the blade. As it applies to the workpiece, that area which will be or has been cut by the blade.

## **Set**

The distance that the tip of the saw blade tooth is bent (or set) outward from the face of the blade.

## **Snipe (planers)**

Depression made at either end of a workpiece by cutter blades when the workpiece is not properly supported.

## **Through Sawing**

Any cutting operation where the blade extends completely through the thickness of the workpiece.

## **Throw-Back**

The throwing back of a workpiece usually caused by the workpiece being dropped into the blade or being placed inadvertently in contact with the blade.

## **Workpiece or Material**

The item on which the operation is being done.

## **Worktable**

Surface where the workpiece rests while performing a cutting, drilling, planing, or sanding operation.

# FEATURES

## PRODUCT SPECIFICATIONS

Feed Rate .....26 FPM  
 Input ..... 120 V, 60 Hz, AC Only, 15 Amp  
 No Load Speed .....10,000 r/min. (RPM)

Max. Planing Height .....6 in.  
 Max. Planing Width .....13 in.  
 Max. Planing Depth .....1/8 in.

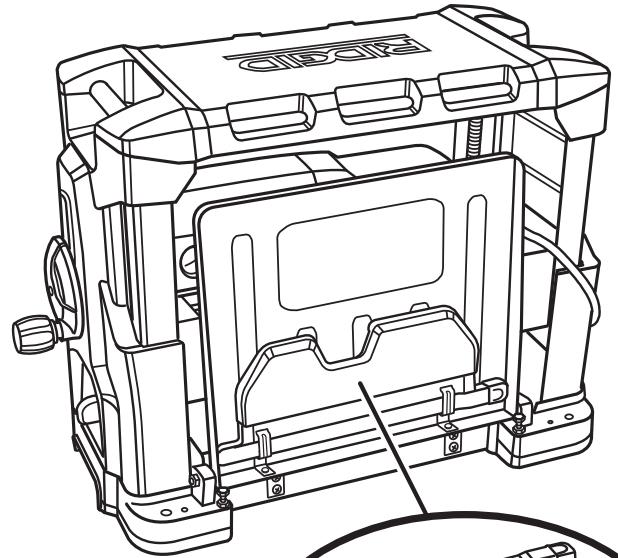
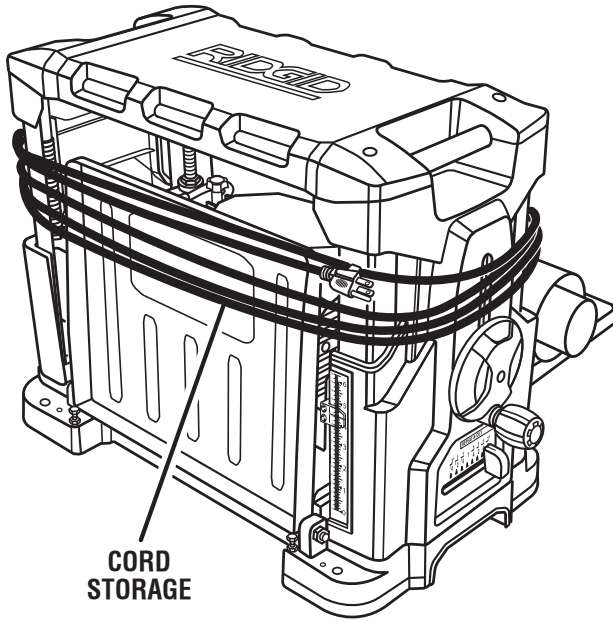

**CORD  
STORAGE**

**BLADE / TOOL  
STORAGE**

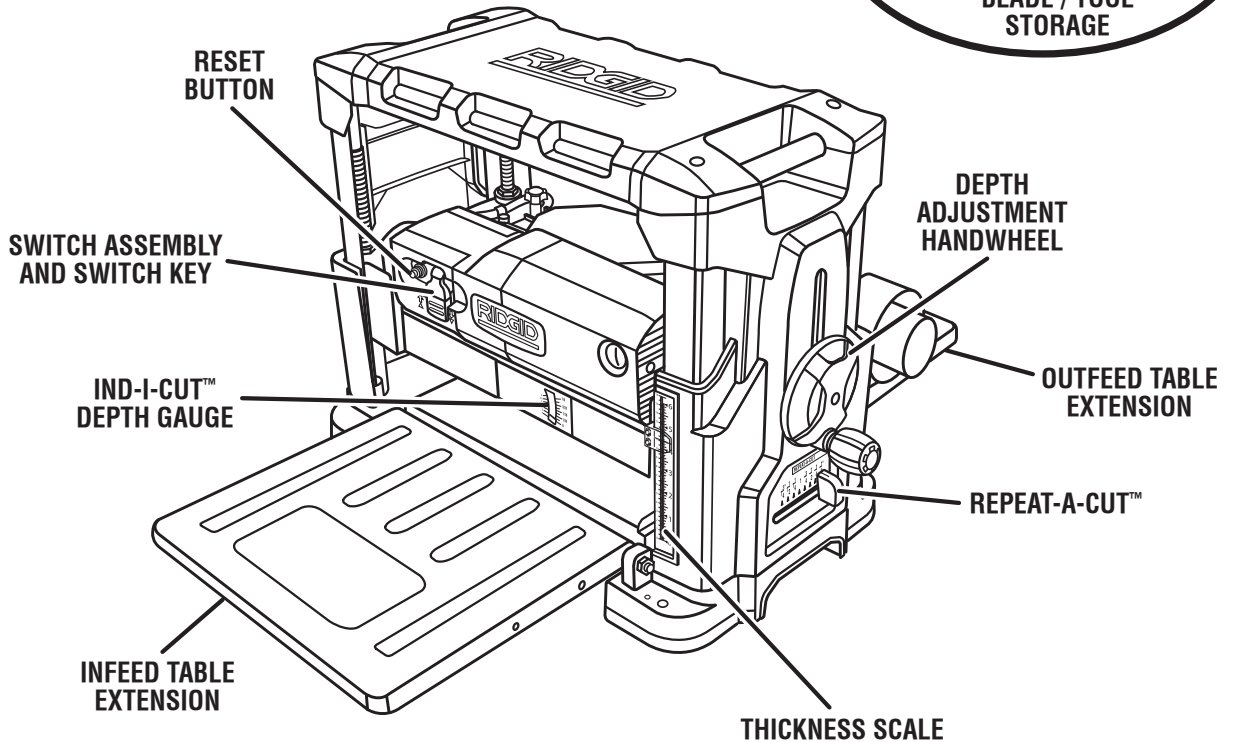

**RESET  
BUTTON**

**SWITCH ASSEMBLY  
AND SWITCH KEY**

**IND-I-CUT™  
DEPTH GAUGE**

**INFEED TABLE  
EXTENSION**

**THICKNESS SCALE**

**DEPTH  
ADJUSTMENT  
HANDWHEEL**

**OUTFEED TABLE  
EXTENSION**

**REPEAT-A-CUT™**

Fig. 3

# FEATURES

---

## KNOW YOUR PLANER

See Figure 3.

The safe use of this product requires an understanding of the information on the tool and in this operator's manual as well as a knowledge of the project you are attempting. Before use of this product, familiarize yourself with all operating features and safety rules.

### 15 AMP MOTOR

The planer has a powerful 15 amp motor with sufficient power to handle tough cutting jobs.

### AUTOMATIC FEED

Infeed and outfeed rollers feed the wood through the planer.

### BLADE / TOOL STORAGE

A magnetic blade tool and 4 mm hex key are located in blade / tool storage under the rear table extension. For your convenience, an extra set of blades can be stored in the blade / tool storage.

### DEPTH ADJUSTMENT HANDWHEEL

The depth adjustment handwheel is used to raise and lower the cutterhead assembly.

### DUST HOOD

Attaching either a 2-1/2 in. or 4 in. shop vac hose to the dust hood helps minimize sawdust accumulation on the workpiece.

## TOOLS NEEDED

---

The following tools (not included) are needed for assembly and alignment:

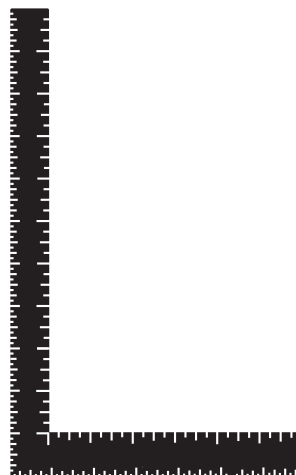

FRAMING SQUARE

### IND-I-CUT™ DEPTH GAUGE

The Ind-I-Cut™ depth gauge is located on the front of your planer and measures depth of cuts up to 1/8 in.

### REPEAT-A-CUT™

The Repeat-A-Cut™, located on the right side of the planer, has preset measurements for repetitive planing.

### RESET BUTTON

Opens the power line circuit when the motor temperature exceeds a safe level, when the motor is overloaded, or when a lower voltage condition exists.

### SCALE

Quickly check the thickness of a workpiece.

### SWITCH ASSEMBLY AND SWITCH KEY

The planer has an easy access switch. To lock in the **OFF** position, remove the switch key. Place the key in a location inaccessible to children and others not qualified to use the tool.

### TABLE EXTENSIONS

Infeed and outfeed table extensions are attached to the machine and fold upright for easy storage. These table extensions are helpful when planing long workpieces.

### THICKNESS SCALE

The thickness scale accurately displays the height of the cutter blades to a maximum of 6 in.

Fig. 4

# LOOSE PARTS

The following items are included with the tool:

- Blade / tool storage
- Switch key
- Hex key (4 mm)
- Magnetic blade tool
- Hex head screw (2)
- Depth adjustment handwheel
- Dust hood
- Dust hood knobs (2)
- Handwheel knob
- Operator's manual

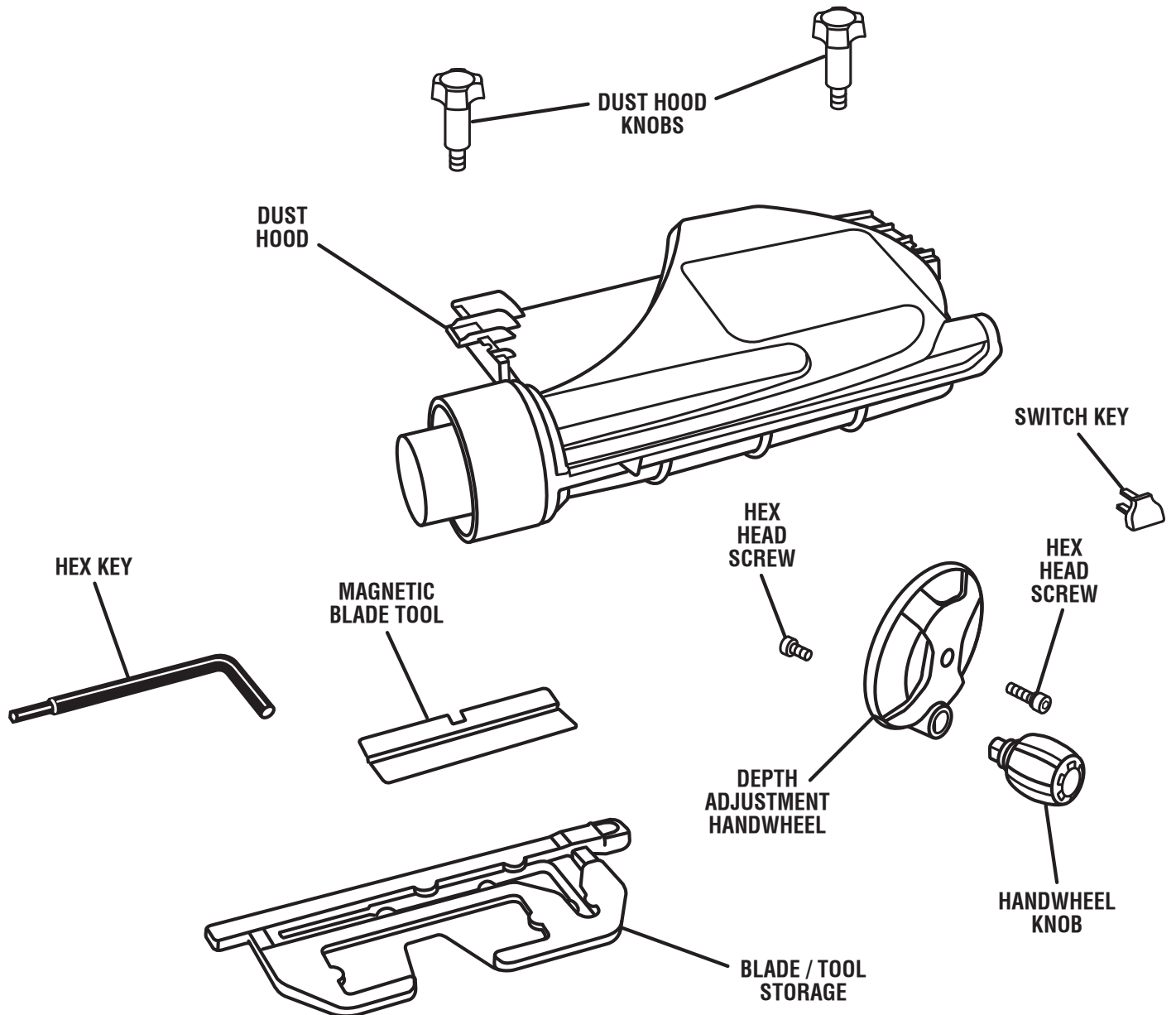

Fig. 5

## **⚠ WARNING:**

The use of attachments or accessories not listed might be hazardous and could cause serious personal injury.



# ASSEMBLY

## UNPACKING

This product requires assembly.

**NOTE:** Every RIDGID® Thickness Planer is tested at the factory to insure its performance. You may see small amounts of wood dust and chips on your new planer.

- Carefully lift the tool from the carton and place it on a level work surface.

**NOTE:** This tool is heavy. To avoid back injury, lift with your legs, not your back, and get help when needed.

- Inspect the tool carefully to make sure no breakage or damage occurred during shipping.
- Do not discard the packing material until you have carefully inspected and satisfactorily operated the tool.
- Remove the dust hood from its position on top of the motor housing then remove the cardboard from the cutterhead.

**NOTE:** Install the dust hood before using this product.

- Remove the blue plastic covering the planer table prior to turning on this product.
- The tool is factory set for accurate cutting. After assembling it, check for accuracy. If shipping has influenced the settings, refer to specific procedures explained in this manual.
- If any parts are damaged or missing, please call 1-866-539-1710 for assistance.

### **WARNING:**

If any parts are damaged or missing, do not operate this tool until the missing parts are replaced. Failure to heed this warning could result in serious personal injury.

### **WARNING:**

Do not attempt to modify this tool or create accessories not recommended for use with this tool. Any such alteration or modification is misuse and could result in a hazardous condition leading to possible serious personal injury.

### **WARNING:**

Do not connect to power supply until assembly is complete. Failure to comply could result in accidental starting and possible serious personal injury.

## MOUNTING THE PLANER TO WORKBENCH

If your planer is to be used in a permanent location, it is recommended you secure it to a workbench or other stable surface. When mounting the planer to a workbench, holes should be drilled through the supporting surface of the workbench.

- Mark holes on workbench where planer is to be mounted using holes in planer base as a template for hole pattern.
- Drill four holes through workbench.
- Place planer on workbench aligning holes in the planer base with holes drilled in the workbench.
- Insert four bolts (not included) and tighten securely with lock washers and hex nuts (not included).

**NOTE:** All bolts should be inserted from the top. Install the lock washers and hex nuts from the underside of the workbench.

Supporting surface where planer is mounted should be examined carefully after mounting to insure that no movement during use can result. If any tipping or walking is noted, secure workbench or support surface before beginning planing operation.

## CLAMPING PLANER TO WORKBENCH

See Figure 6.

If the planer is to be used as a portable tool, it is recommended you fasten it permanently to a mounting board that can easily be clamped to a workbench or other stable surface. The mounting board should be of sufficient size to avoid tipping while planer is in use. Any good grade plywood or chipboard with a 3/4 in. thickness is recommended.

- Mark holes on board where planer is to be mounted using holes in planer base as a template for hole pattern.
- Follow last three steps in section **Mounting Planer to Workbench**.

If lag bolts are used, make sure they are long enough to go through holes in planer base and material the planer is being mounted to. If machine bolts are used, make sure bolts are long enough to go through holes in planer base, the material being mounted to, and the lock washers and hex nuts.

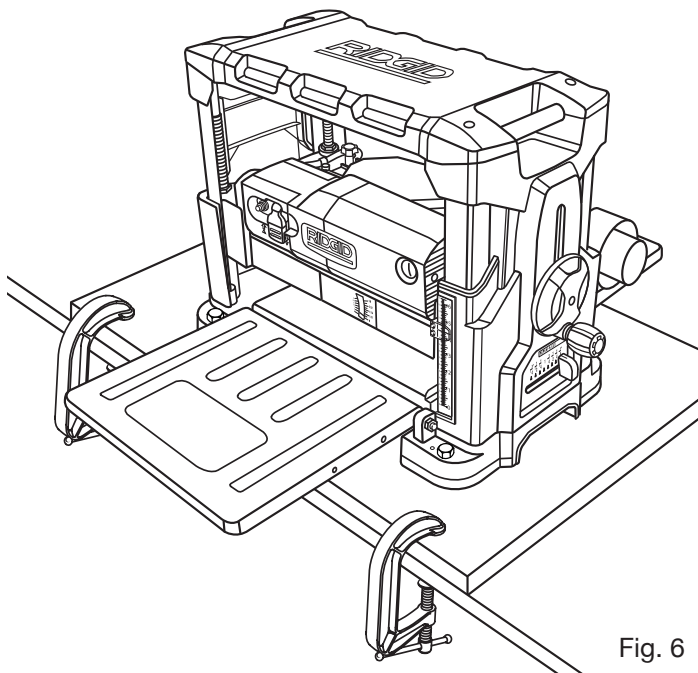

Fig. 6

# ASSEMBLY

## INSTALLING HANDWHEEL KNOB

See Figure 7.

- Locate the handwheel knob and screw from among the loose parts. Insert the screw through the hole in the handwheel and tighten screw securely.
- Using the hex head screw, attach the depth adjustment handwheel securely to the planer.

## INSTALLING THE DUST HOOD

See Figure 8.

From the back of the machine, slip the slot on the dust hood over the tab inside the planer and align the dust hood over the holes on the side of the planer. Install the dust hood knobs by turning them clockwise.

To minimize sawdust accumulation on your workpiece, attach either a 2-1/2 in. shop vac or a 4 in. dust collection system to the dust hood.

**NOTE:** The end of a 4 in. hose fits over the dust adaptor and requires a clamp (not included) to secure.

To open and close the dust hood door, align the arrows on the side.

**NOTE:** With the dust hood open, the sawdust is ejected from the back. With the dust hood closed, the sawdust is ejected from the adaptor.

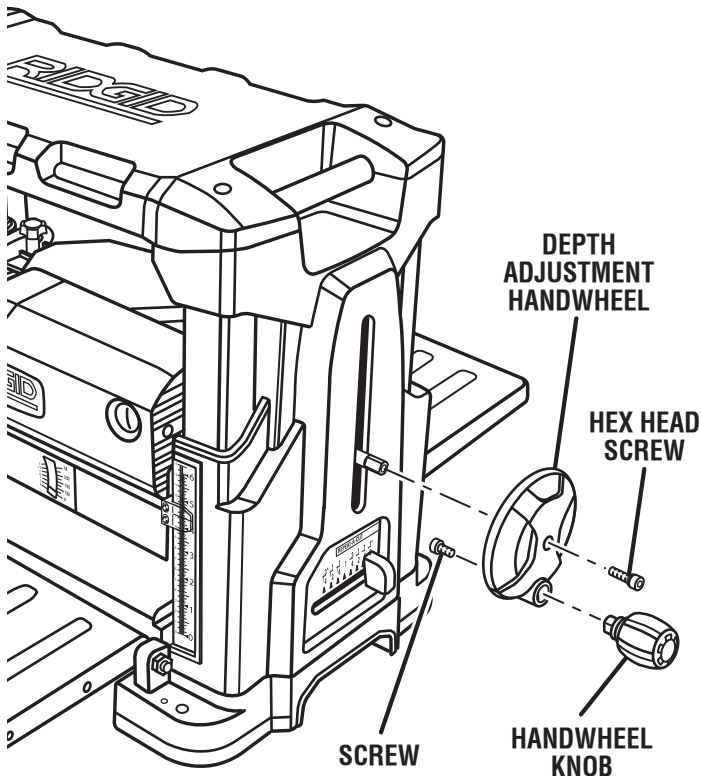

Fig. 7

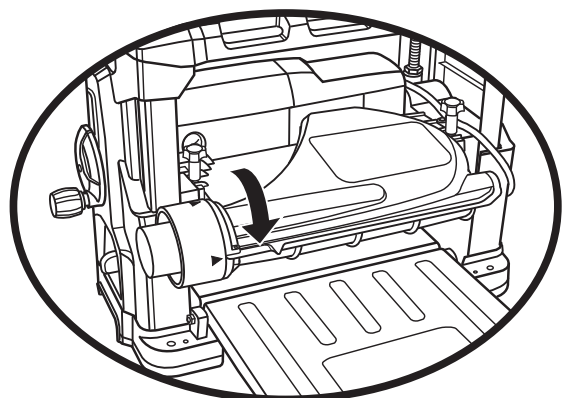
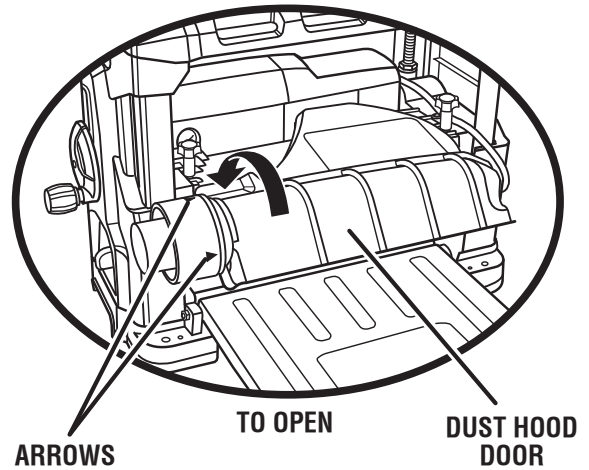
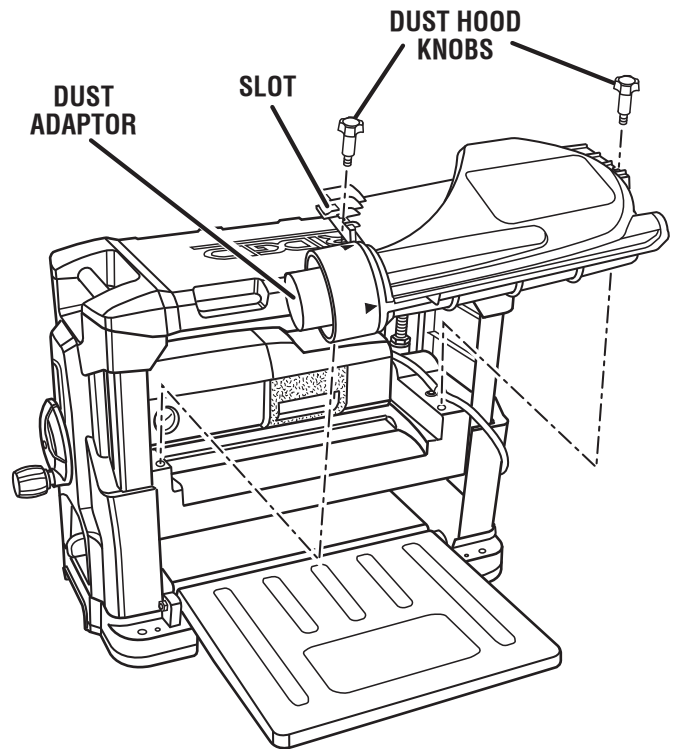

Fig. 8



# ASSEMBLY

## LEVELING THE TABLE EXTENSIONS

See Figure 9.

The infeed and outfeed table extensions are attached to the planer. Shipped in a folded, upright position, the table extensions must be in the down position before planing can begin. For accurate planing, table extensions must be level with the planer table.

**NOTE:** For optimum performance, always check to make sure the table extensions are level before beginning planing operations.

- Place a straight edge or level across both the planer table and table extensions.
- If adjustment is necessary, lift table extensions and loosen lock nuts. Adjust stop screws (one on each side) until extension table is level with planer table.
- Press down on the table extension to ensure the table extension is properly seated.
- Tighten lock nuts securely when adjustments are complete.

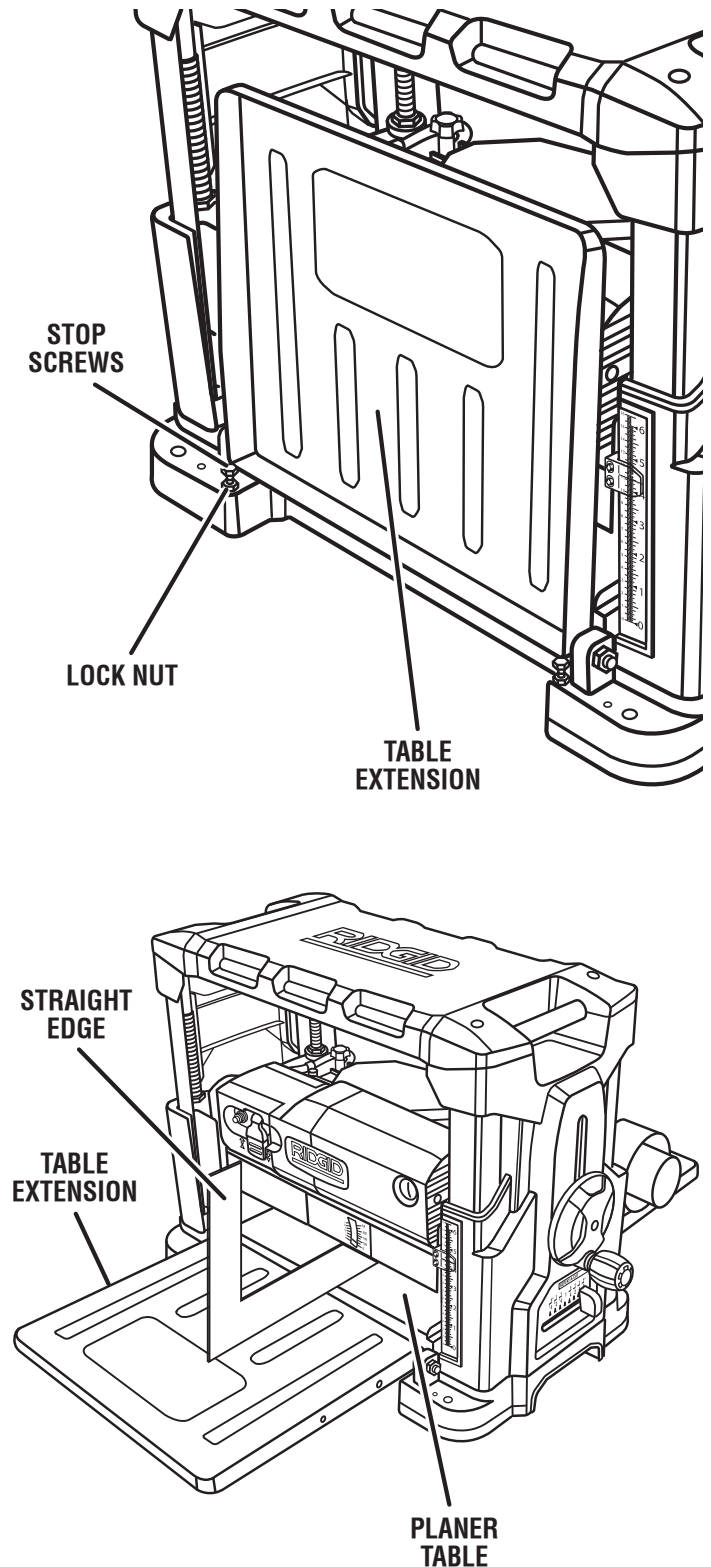

Fig. 9

# OPERATION

---

---

## WARNING:

Do not allow familiarity with tools to make you careless. Remember that a careless fraction of a second is sufficient to inflict serious injury.

---

---

## WARNING:

Always wear safety goggles or safety glasses with side shields when operating power tools. Failure to do so could result in objects being thrown into your eyes resulting in possible serious injury.

---

---

## WARNING:

Do not use any attachments or accessories not recommended by the manufacturer of this tool. The use of attachments or accessories not recommended can result in serious personal injury.

---

---

## WARNING:

The use of this planer on materials not listed may damage the planer and may cause serious personal injury.

---

---

## WARNING:

Never plane workpiece with loose knots or foreign objects. Do not plane workpieces that are severely bowed, twisted, or knotted. Cutter blades can dull, chip, or break causing possible serious personal injury.

---

---

## WARNING:

Do not force feed the workpiece through the machine. Let the planer apply the proper feed rate.

---

## APPLICATIONS

You may use this tool for the purpose listed below:

- Planing the surface of a piece of lumber.

## THICKNESS PLANING

Thickness planing sizes workpiece to desired thickness while creating a smooth, level surface. Thickness of each cut will depend on type of wood (hardwood versus softwood), width of workpiece, straightness, dryness, and grain composition. Whenever working with a new type of wood, make thin test cuts on a scrap piece of wood first to determine potential problems with the workpiece.

## PLANING TIPS

- Thickness planers work best if at least one side of the workpiece has a flat surface. When both sides of a workpiece are rough, use a surface planer or jointer first to define the initial flat surface. Plane one side of the workpiece then flip the workpiece and plane the surface of the reverse side.
- Always plane both sides of a workpiece to reach the desired thickness. This will leave the workpiece with uniform moisture to prevent warp during the drying process.
- When one end of the workpiece is thicker than the opposite end by more than 1/8 in., make several cuts with the planer starting with light planing cuts first. Remember, light cuts create a finer finish than heavier cuts.
- Do not plane a workpiece less than 5/16 in. thick.
- Do not plane a workpiece less than 3/4 in. wide.
- Do not plane workpiece shorter than 14 in. long as this will cause kickback.
- Do not plane more than one workpiece at a time.
- Do not lower the cutterhead assembly lower than 5/16 in.
- Do not continuously use the planer set at the maximum depth of cut (1/8 in.) and at full width of cut (13 in.). Continuous use at maximum cutting capacity will damage the motor.
- Worn cutter blades will affect cutting accuracy. Planing with dull or nicked cutter blades may produce ridges or rough workpiece surfaces.
- Gum and pitch on the cutter blades will cause them to wear prematurely. Using a gum and pitch remover to keep your cutter blades clean will prolong their wear.
- Refer to the *Maintenance* section of this operator's manual for instructions on how to remove and replace or turn the cutter blades.

**NOTE:** Cutter blades are double-edged and can be turned once to the opposite, unused edge before replacement is required. Cutter blades must ALWAYS be replaced as a set.

# OPERATION

## AVOIDING SNIPE

Snipes, or depressions made at either end of a workpiece by cutter blades, can occur when the board is not properly supported. Although snipe may be barely noticeable, it is important to keep the workpiece parallel and flat with the planer table to minimize snipe. Butting workpieces end-to-end as they are fed through the planer will minimize the problem, especially for shorter pieces, because it provides a more stable feed.

For workpieces longer than 48 in., greater care must be taken to reduce the problem because the additional length means more of the total weight is unsupported by the planer table and rollers, causing the shifting weight to work against keeping the stock flat.

To remove snipe from a finished workpiece, cut off the end of the workpiece where snipe is noticeable.

## WARPED WOOD

Little or no warpage is the ideal condition for planing a workpiece. Simply turn the workpiece over and plane it to the desired thickness. Otherwise, plane the top first, turn the workpiece and plane the bottom.

For a board that is cupped or bowed across its width, the best method is to rip the board lengthwise down the middle and plane the pieces separately. This method eliminates much of the waste in planing cupped or bowed workpieces.

The only way to remove the bow from a workpiece that is cupped or bowed down its length is to use a jointer.

Avoid using severely warped wood as it can jam the planer. If it must be used, rip it in half before planing to help minimize the possibility of jamming. If jamming does occur, turn the switch off and unplug the planer immediately. Raise the cutterhead assembly high enough to remove the workpiece easily. Carefully check to make sure no damage to the tool has occurred before making the next planing pass.

Always feed the workpiece in the direction of the grain. This allows the cutter blades to sever the wood fibers instead of tearing them. Feeding against the grain can also cause the cutter blades to chip the workpiece.

## POWER SWITCH

See Figure 10.

The planer is equipped with a power switch that has a built-in locking feature. This feature is intended to prevent unauthorized and possible hazardous use by children and others.

### TO TURN THE PLANER ON:

- With the switch key inserted into the switch, lift the switch to turn **ON (I)**.

### TO TURN THE PLANER OFF:

- With the switch key inserted into the switch, push the switch down to turn **OFF (O)**.

### TO LOCK THE PLANER:

- Place the switch in the **OFF (O)** position.
- Remove the switch key from the switch and store in a secure location.

### ⚠ WARNING:

Always remove the switch key when the tool is not in use and keep it in a safe place. In the event of a power failure, turn the switch **OFF (O)** and remove the key. This action will prevent the tool from accidentally starting when power returns.

### ⚠ WARNING:

Always make sure the workpiece is not in contact with the blade before operating the switch to start the tool. Failure to heed this warning may cause the workpiece to be kicked back toward the operator and result in serious personal injury.

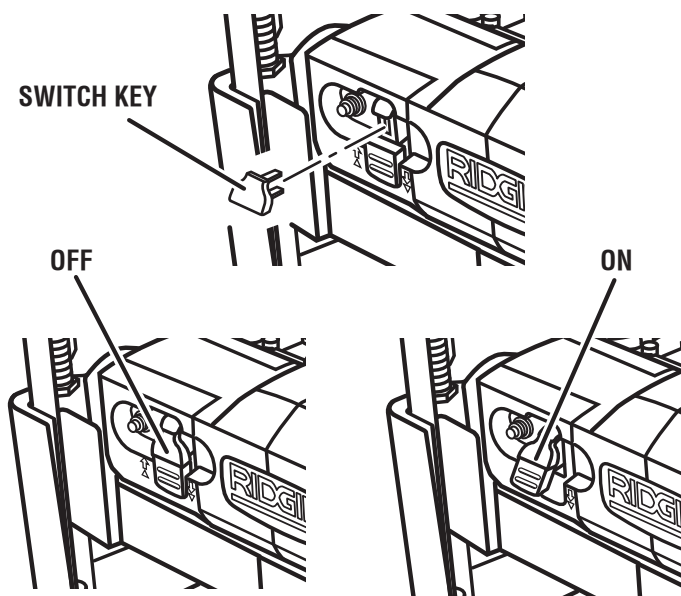

Fig. 10

# OPERATION

## ADJUSTING THE PLANING DEPTH

See Figure 11.

The depth adjustment handwheel is used to set the amount of wood being removed in a planing pass. Never make a planing cut deeper than 1/8 in. for material up to 6 in. wide or 1/16 in. for material between 6 in. and 13 in. wide.

**NOTE:** Do not continuously use the planer at the maximum depth of cut (1/8 in.) as it will damage the motor.

Rotate the depth adjustment handwheel to position the cutterhead at the desired planing depth. Each full revolution of the handle will raise or lower the cutterhead 1/16 in.

## DEPTH GAUGE

See Figure 12.

The depth gauge indicates the amount of wood being removed in a planing pass. The workpiece must be positioned under the depth gauge on the front of the planer.

Never make a planing cut deeper than:

- 1/8 in. for material up to 6 in. wide
- 1/16 in. for material 6 in. - 13 in. wide

Do not continuously use the planer at the maximum depth of cut, 1/8 in., as it will damage the motor.

## PLANING

See Figure 13.

Use scrap wood for your first planing attempt. Once you have planed the wood, check all measurements for accuracy. If measurements are not exact, see *Adjustment* section for further instruction.

Before each use of the planer, check for loose fasteners, fittings, or hardware; be sure the dust hood is securely mounted; and ensure the blade cutter rotates freely. Lower the cutterhead assembly to approximately 1 in. above the planer table surface. Without putting any load on the planer, test the motor by turning the planer on and allowing it to reach full speed. If the planer sounds excessively loud or has excessive vibration, turn off the machine immediately and check again for any loose hardware, retightening any you may find.

### **WARNING:**

To avoid serious personal injury, do not stand directly in line with the front or rear of the planer. If an object is thrown from the planer, it will travel in this direction.

- Stand to one side of the planer infeed area.
- Turn switch **ON ( I )**.
- Lift the work to the table by grasping the edges of the board at approximately the middle of the length. Rest the board end on the feed table and direct the board into the planer.

**NOTE:** Boards longer than 24 in. should have additional support from free-standing material stands.

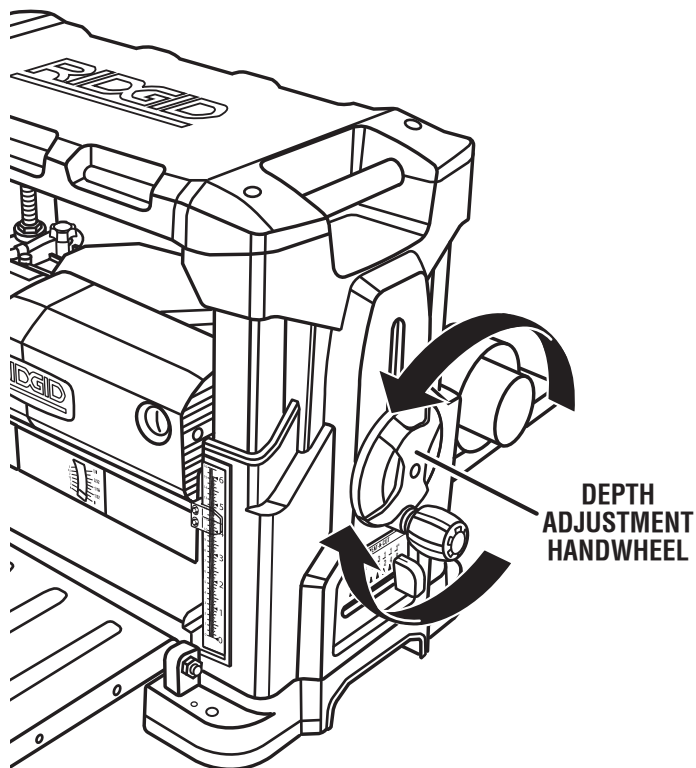

Fig. 11

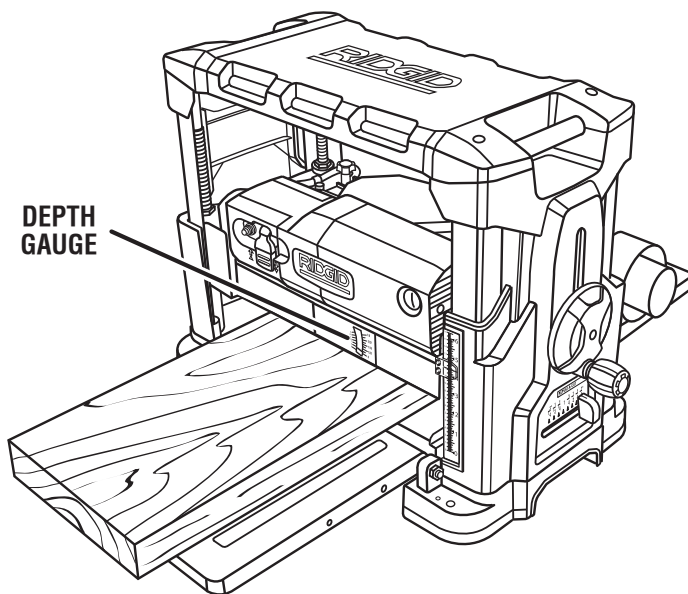

Fig. 12

# OPERATION

- Push slightly on the board and allow the automatic feed to take the board.
- Release the board to allow the automatic feed to function properly. Do not push or pull on the workpiece.
- Move to one side at the rear of the planer and receive the planed lumber by grasping it in the same manner as it was fed. Do not grasp any portion of the board which has not gone past the outfeed area of the table.

## REPLANING USING REPEAT-A-CUT™

See Figure 14.

The planer has a replane feature using preset markers for repetitive planing. The Repeat-A-Cut™ allows you to plane material at a set measurement. The maximum depth of the replane indicator is 1-3/4 in.

- Raise cutterhead assembly to a height greater than 1-3/4 in.
- Move the replane indicator to the desired height.
- Lower the cutterhead assembly until it stops.
- Stand to one side of the planer infeed area.
- Turn switch **ON ( I )**.
- Plane the workpiece (see **Depth Gauge** on page 19 for maximum depth of cut).
- Repeat above steps until desired planing depth.

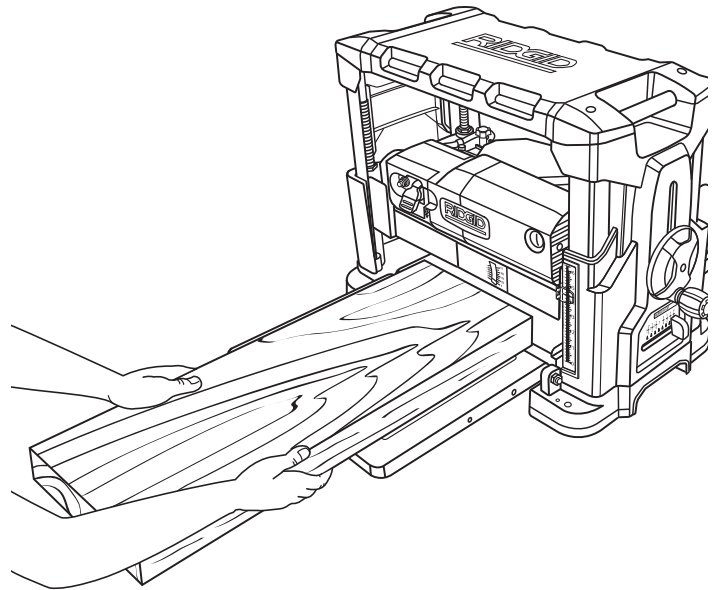

Fig. 13

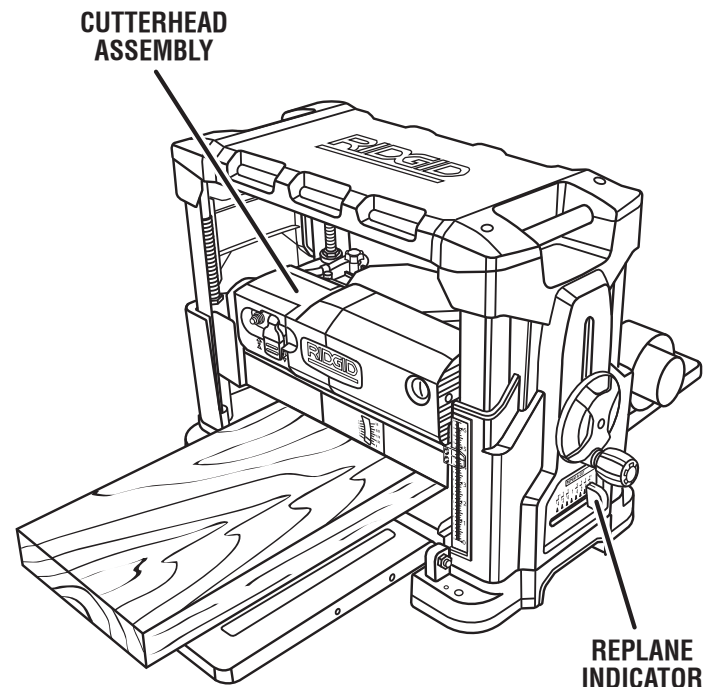

Fig. 14



# ADJUSTMENTS

## **WARNING:**

Before performing any adjustment, make sure the tool is unplugged from the power supply and the switch is in the OFF position. Failure to heed this warning could result in serious personal injury.

## **THICKNESS SCALE ADJUSTMENT**

See Figure 15.

Located on the right front of the planer, the thickness scale shows the depth of the finished workpiece. Inaccurate cuts can be prevented by routinely checking the alignment of the thickness scale.

- Table extensions must be level with planer table.
- Plane a scrap piece of wood then measure the depth of the finished piece.
- If properly adjusted, the depth of the finished piece should be the same as indicated on the thickness scale.
- If out of adjustment, loosen the scale indicator screws holding the scale indicator and adjust the thickness indicator to the correct setting.
- Retighten screws securely.

## **BLADE ADJUSTMENT**

See Figure 16.

Tiny nicks may appear on the blades as a result of picking up sand or other particles on a workpiece and then running the workpiece through the planer. Slight adjustments can be made to one or both blades to offset such planing imperfections.

- Unplug the planer.
- Lower the cutterhead assembly.
- Remove the dust hood knobs holding the dust hood in place; remove hood and set aside.

## **WARNING:**

To avoid injury, NEVER rotate the cutterhead by hand.

- Using the hex key, loosen the blade locking screws that secure the blade in the cutterhead.
- Push the notched end of the cutter blade on either the left or right side to shift the blade as desired. The blade can be shifted up to 3/64 in.
- Retighten the blade locking screws securely.
- Replace the dust hood and reinstall dust hood knobs to secure.

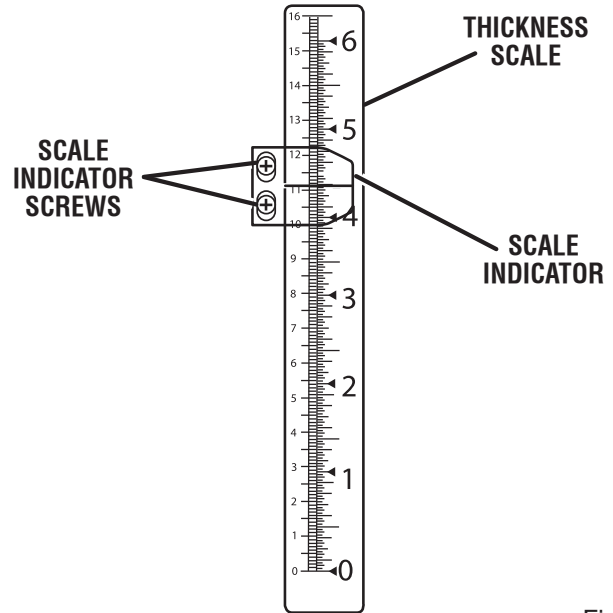

Fig. 15

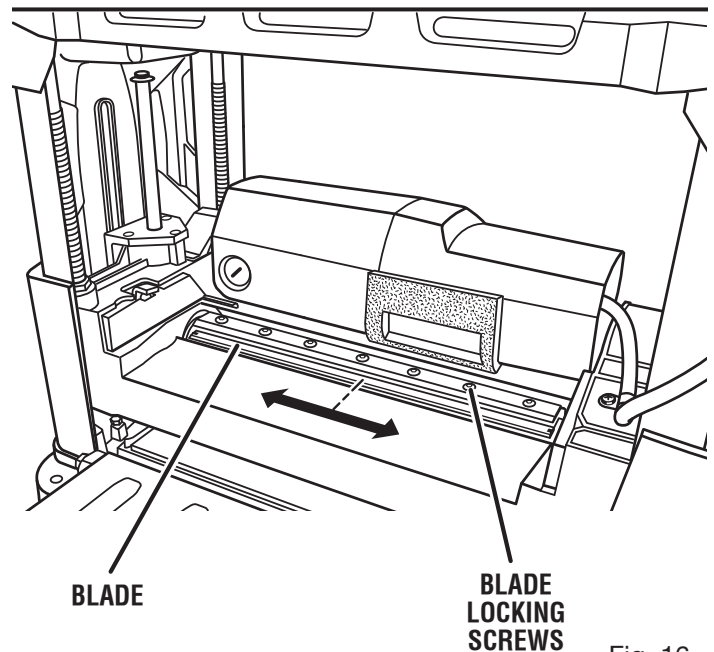

Fig. 16

# ADJUSTMENTS

## REPEAT-A-CUT™

See Figure 17.

Plane a scrap piece of wood and measure the depth of the finished piece. If an adjustment is needed:

- Unplug the planer.
- Pull the replane indicator straight out to remove.
- Using the hex key provided, remove the hex head screw from the depth adjustment handwheel. Remove the handwheel.
- Remove the screws on the top and right side panel of the planer. Carefully lift and pull the side panel cover off.
- Lower the cutterhead assembly until it stops against the stop screw.
- Using an accurate ruler or a scrap piece of wood, check the measurement against the replane indicator setting.
- If adjustment is necessary, use a wrench to loosen the lock nut and adjust the stop screw to the correct height.
- Once the adjustment is made, retighten the lock nut and stop screw securely.
- Replace the top and side panel, and secure using the set screw.
- Replace the handwheel and hex head screw.
- Replace the replane indicator.

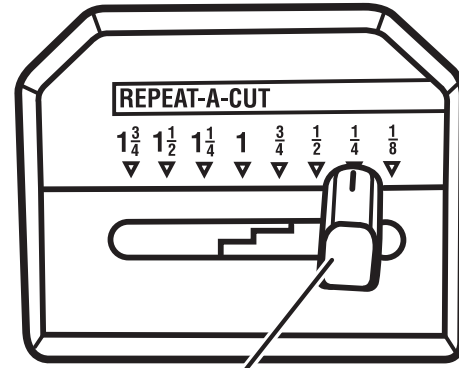

REPLANE  
INDICATOR

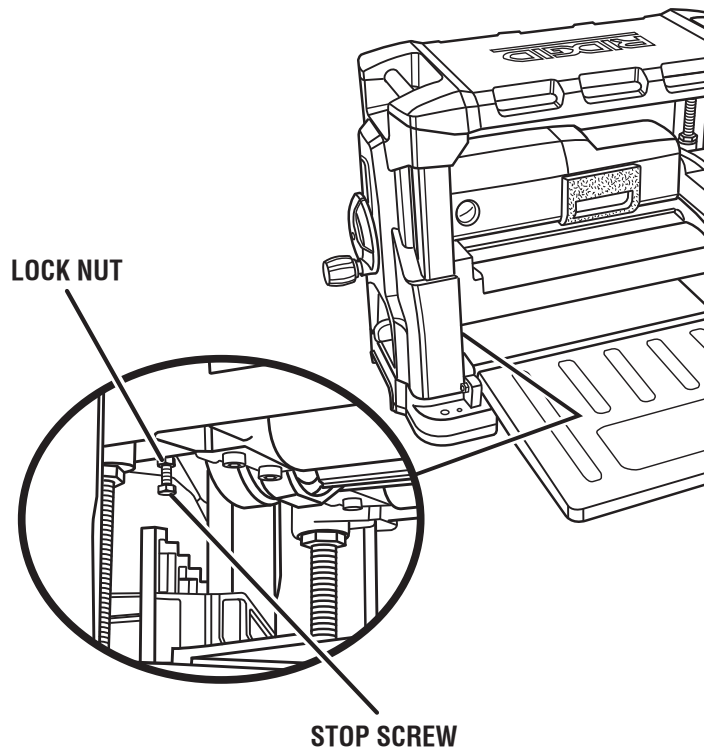

Fig. 17



# MAINTENANCE

---

## **⚠ WARNING:**

When servicing, use only identical replacement parts. Use of any other part may create a hazard or cause product damage.

---

## **⚠ WARNING:**

Always wear safety goggles or safety glasses with side shields during power tool operation or when blowing dust. If operation is dusty, also wear a dust mask.

---

## GENERAL MAINTENANCE

Avoid using solvents when cleaning plastic parts. Most plastics are susceptible to damage from various types of commercial solvents and may be damaged by their use. Use clean cloths to remove dirt, carbon dust, etc.

---

## **⚠ WARNING:**

Do not at any time let brake fluids, gasoline, petroleum-based products, penetrating oils, etc., come in contact with plastic parts. They contain chemicals that can damage, weaken, or destroy plastic.

---

## LUBRICATION

All of the bearings in this tool are lubricated with a sufficient amount of high grade lubricant for the life of the unit under normal operating conditions. Therefore, no further lubrication is required.

---

## **⚠ WARNING:**

To ensure safety and reliability, all repairs should be performed by a qualified service technician at an authorized service center to avoid risk of personal injury.

---

## MOTOR/ELECTRICAL

The universal motor is easy to maintain but must be kept clean. Do not allow water, oil, or sawdust to accumulate on or in it. The sealed bearings are permanently lubricated and need no further attention.

---

## CLEANING

Sawdust buildup and other debris can cause the tool to plane inaccurately. Periodic cleaning and waxing is needed for accurate, precision planing.

Do not allow sawdust to accumulate on the planer. Clean the dust hood after each use.

---

## **⚠ DANGER:**

Rotating blades under dust hood. In order to avoid personal injury, keep fingers away.

---

Moving parts should be cleaned regularly with penetrating oil and lubricated with a light coating of medium-weight machine oil.

Paste wax should be applied to the planing table surface to ease the movement of workpieces across it, but be careful not to use so much that it will be absorbed into the wood and interfere with staining.

Check feed rollers after each use for resin buildup, because feed rollers must be clean to be effective. If buildup occurs, use a mild, nonflammable tar and pitch remover.

---

## BLADE / TOOL STORAGE

See figure 18.

For your convenience, an extra set of blades can be stored under the outfeed table extension in the blade / tool storage.

Dispose of used blades properly. Wrap blades in tape before disposal to avoid accidental injury.

---

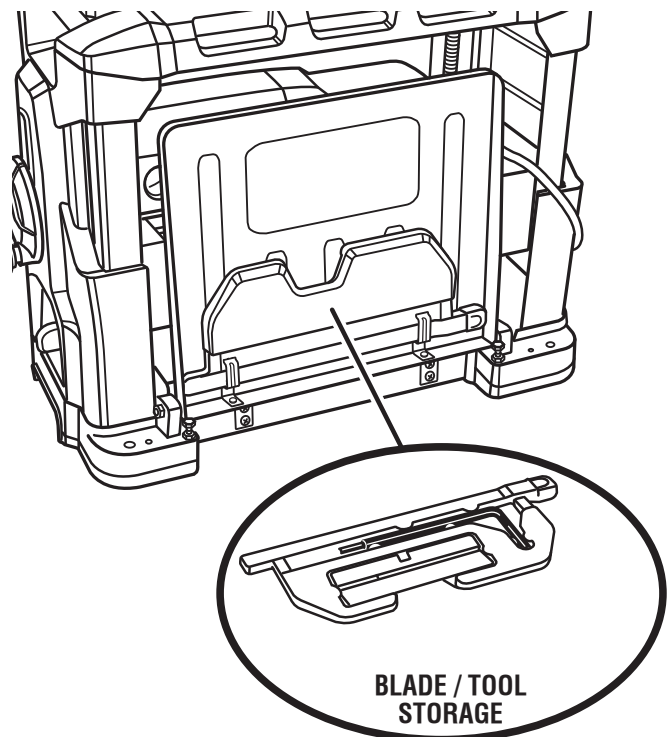

Fig. 18

# MAINTENANCE

## CORD STORAGE

See Figure 19.

For convenience, your planer comes equipped with cord storage. When not in use, the power cord should be wrapped around the planer.

### **CAUTION:**

Check extension cords before each use. If damaged, replace immediately. Never use tool with a damaged cord since touching the damaged area could cause electrical shock resulting in serious injury.

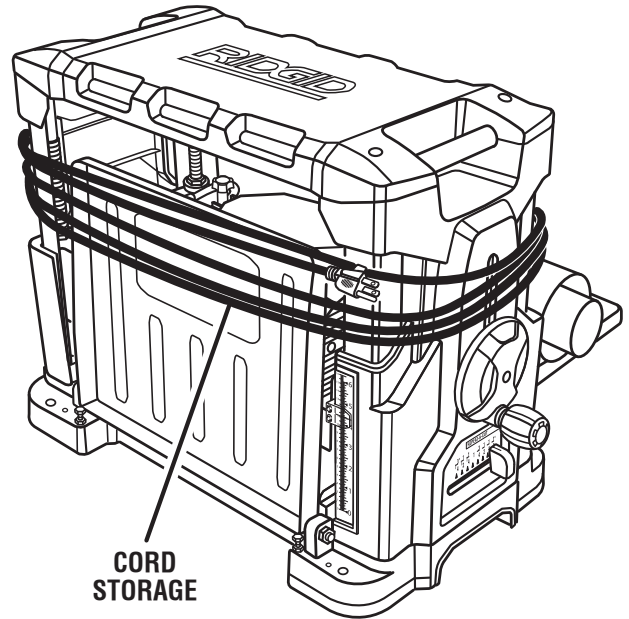

Fig. 19

## BRUSH REPLACEMENT

See Figure 20.

Externally accessible brush assemblies are located at the right front and the left rear of the planer. These brushes should be inspected every 10 to 15 operating hours for wear. Replace both brushes when either brush has less than 1/4 in. of carbon remaining.

**NOTE:** The dust hood may be removed for easier access when removing the rear brush cap.

- Unplug planer and remove the switch key.
- Using a flat-head screwdriver, unscrew the brush cap. The brush assembly is spring-loaded and will pop out when you remove the cap.
- Remove the brush assembly (brush and spring) and inspect for wear. If less than 1/4 in. of carbon remains on brush, replace both brush assemblies. Never replace one side without replacing the other.
- Install new brush assembly, if required, or reinstall old brush assembly.
- Replace cap and tighten to secure.

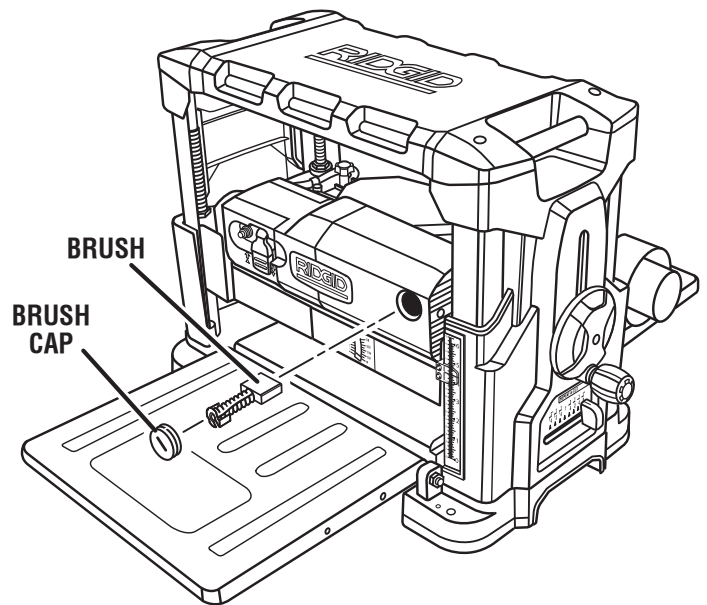

Fig. 20

# MAINTENANCE

## BLADE REPLACEMENT

See Figures 21 - 23.

The planer is equipped with replaceable/disposable double-edged cutter blades attached to a rotating cutterhead. Worn cutter blades will affect cutting accuracy and may produce ridges on the workpiece.

- Unplug the planer.
- Lower the cutterhead assembly.
- From the back of the planer, remove the two dust hood knobs holding the dust hood in place.
- Remove the dust hood.

**NOTE:** The cutterhead lock will engage when the head is rotated. Do not operate thickness planer without the dust hood in place or the planer will be damaged.

- If necessary, rotate the cutterhead until it locks.

**NOTE:** Rotating the cutterhead is accomplished from beneath the cutterhead assembly. Using the planer table as a mirror, touch the threaded spindle where it attaches to the planer table. Carefully move your fingers up until you touch the drive belt. Turn the drive belt with your fingers until the cutterhead locks in place.

- Carefully loosen, but do not remove, the blade locking screws.
- Using the magnetic blade tool, remove the blade by placing the blade tool on the blade, lifting slightly, then pulling the blade straight out.
- If you are changing to the second side of the blade, rotate the blade “end for end” keeping the same flat side down. This correctly positions the blade for reinstallation.
- Using the magnetic blade tool, push the installed blade in firmly. Check that the blade edge is parallel to the cutterhead slot.
- Securely retighten the blade locking screws.
- To rotate the cutterhead to the next blade, hold down on the red cutterhead lock and rotate the cutterhead 120° as shown in figure 21.
- Release the cutterhead lock and continue to rotate the cutterhead until it locks in place. This correctly positions the blade for removal.
- Repeat the above steps for each blade.
- Replace the dust hood.

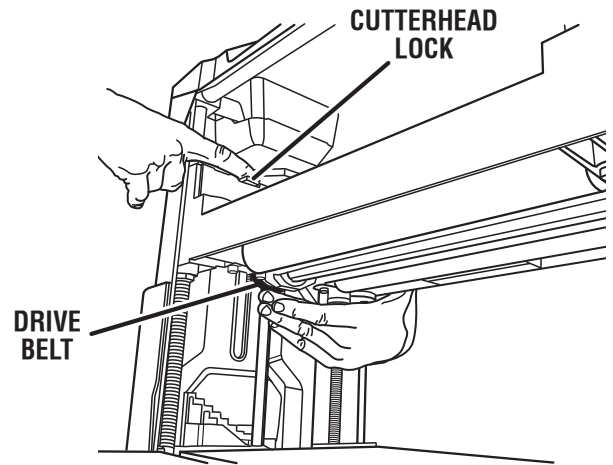

Fig. 21

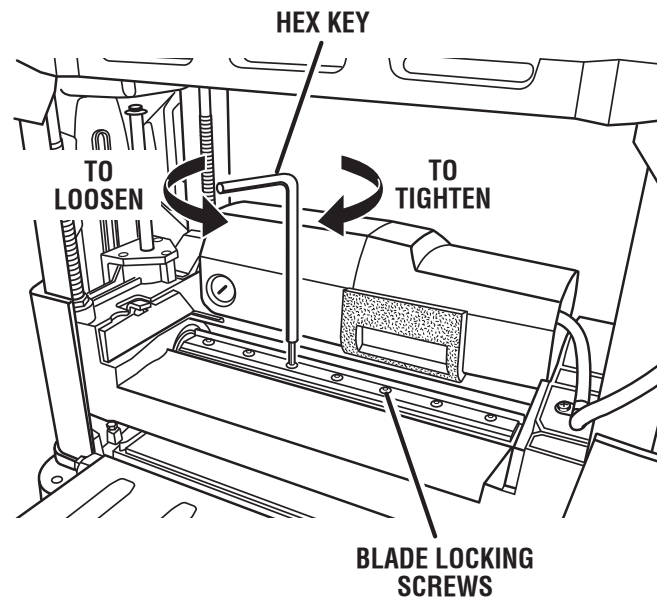

Fig. 22

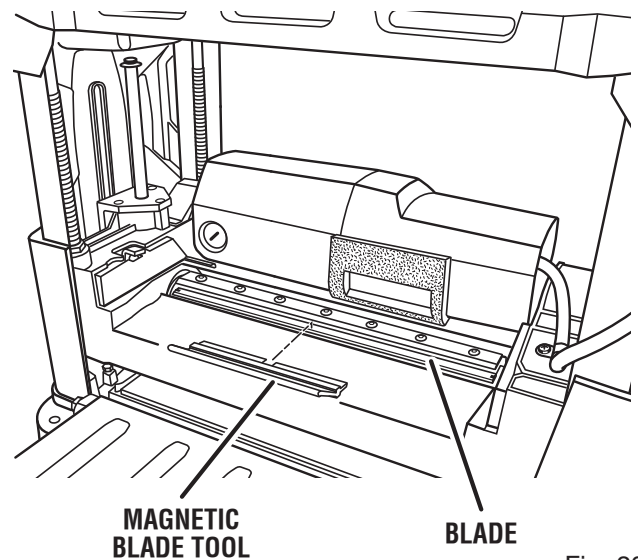

Fig. 23

# TROUBLESHOOTING

PROBLEM	POSSIBLE CAUSE	SOLUTION
Snipe (depressions at ends of workpiece)	Dull cutter blades Incorrect butted stock  Unit not securely mounted	Replace or turn cutter blades. Butt pieces end-to-end as they are fed into planer. Tighten lag bolts.
Torn grain	Too deep a blade setting Workpiece being fed against grain Dull cutter blades	Reduce depth of cut. Feed other end of board first. Replace or turn cutter blades.
Fuzzy/rough grain	High wood moisture content Dull cutter blades Too deep a blade setting Incorrect feeding speed	Dry wood before planing. Replace or turn cutter blades. Reduce depth of cut. Check for adequate power supply. Check cord and plug for damage. Check condition of motor brushes.
Uneven depth of cut	Cutterhead assembly not level with planer surface Unstable roller spring pressure  Feed roller worn unevenly	Adjust elevation nuts.  Have service performed by an authorized service center. Have service performed by an authorized service center.
Board thickness does not match depth scale indicator	Depth scale incorrectly set Dirty planing table	Adjust depth scale. Clean and wax planing table.
Cutterhead height difficult to adjust	Dirty spindle Worn chain	Clean and lubricate spindle. Have service performed by an authorized service center.
Will not start	Not plugged in Blown circuit  Motor failure  Loose wire  ON/OFF switch malfunction  Motor is overloaded	Check power source. Replace fuse, reset breaker, or call electrician.  Have service performed by an authorized service center.  Have service performed by an authorized service center.  Have service performed by an authorized service center. Push reset button.
Interrupted operation	Unit overloaded Circuit overloaded	Reduce load. Operate on circuit separate from other appliances or motors or connect to circuit with adequate amp rating.

# WARRANTY

---

## RIDGID® HAND HELD AND STATIONARY POWER TOOL 3 YEAR LIMITED SERVICE WARRANTY

Proof of purchase must be presented when requesting warranty service.

Limited to RIDGID® hand held and stationary power tools purchased 2/1/04 and after. This product is manufactured by One World Technologies, Inc. The trademark is licensed from RIDGID®, Inc. All warranty communications should be directed to One World Technologies, Inc., attn: RIDGID® Hand Held and Stationary Power Tool Technical Service at (toll free) 1-866-539-1710.

### 90-DAY SATISFACTION GUARANTEE POLICY

During the first 90 days after the date of purchase, if you are dissatisfied with the performance of this RIDGID® Hand Held and Stationary Power Tool for any reason you may return the tool to the dealer from which it was purchased for a full refund or exchange. To receive a replacement tool you must present proof of purchase and return all original equipment packaged with the original product. The replacement tool will be covered by the limited warranty for the balance of the 3 YEAR service warranty period.

### WHAT IS COVERED UNDER THE 3 YEAR LIMITED SERVICE WARRANTY

This warranty on RIDGID® Hand Held and Stationary Power Tools covers all defects in workmanship or materials and normal wear items such as brushes, chucks, motors, switches, cords, gears and even cordless batteries in this RIDGID® tool for three years following the purchase date of the tool. Warranties for other RIDGID® products may vary.

### HOW TO OBTAIN SERVICE

To obtain service for this RIDGID® tool you must return it; freight prepaid, or take it in to an authorized service center for RIDGID® branded hand held and stationary power tools. You may obtain the location of the authorized service center nearest you by calling (toll free) 1-866-539-1710 or by logging on to the RIDGID® website at [www.ridgid.com](http://www.ridgid.com). When requesting warranty service, you must present the original dated sales receipt. The authorized service center will repair any faulty workmanship, and either repair or replace any part covered under the warranty, at our option, at no charge to you.

### WHAT IS NOT COVERED

This warranty applies only to the original purchaser at retail and may not be transferred. This warranty only covers defects arising under normal usage and does not cover any malfunction, failure or defect resulting from misuse, abuse, neglect, alteration, modification or repair by other than an authorized service center for RIDGID® branded hand held and stationary power tools. Consumable accessories provided with the tool such as, but not limited to, blades, bits and sand paper are not covered.

**RIDGID®, INC. AND ONE WORLD TECHNOLOGIES, INC. MAKE NO WARRANTIES, REPRESENTATIONS OR PROMISES AS TO THE QUALITY OR PERFORMANCE OF ITS POWER TOOLS OTHER THAN THOSE SPECIFICALLY STATED IN THIS WARRANTY.**

### ADDITIONAL LIMITATIONS

To the extent permitted by applicable law, all implied warranties, including warranties of MERCHANTABILITY or FITNESS FOR A PARTICULAR PURPOSE, are disclaimed. Any implied warranties, including warranties of merchantability or fitness for a particular purpose, that cannot be disclaimed under state law are limited to three years from the date of purchase. One World Technologies, Inc. and RIDGID®, Inc. are not responsible for direct, indirect, incidental or consequential damages. Some states do not allow limitations on how long an implied warranty lasts and/or do not allow the exclusion or limitation of incidental or consequential damages, so the above limitations may not apply to you. This warranty gives you specific legal rights, and you may also have other rights which vary from state to state.

---

**One World Technologies, Inc.**

P.O. Box 35, Hwy. 8

Pickens, SC 29671

---

