

CATSKILL

C R A F T S M E N , I N C .

Assembly Instructions Model 51538

Mid-Sized Island w/Flat Panel Doors & Drop Leaf



GENERAL:

1. You have purchased model 51538.
2. Should you need assistance or need to replace a damaged or missing part simply give us a call M-F at 607-652-7321 from 7:30 am - 4:30 pm EST and we'll send you the prepaid part via UPS usually that same day! You may also email us info@catskillcraftsmen.com.
3. Read the assembly instructions and the enclosed brochure before beginning assembly. Assembly is easy if you read and follow the instructions step by step. See our website for assembly tips and videos.
4. Tools required: Phillips screwdrivers, medium and small; medium flat blade screwdriver and a hammer.
5. Drawer glides are sometimes pre-packed with screws, these are not used.
6. Directions (left/right, front/back) are given as facing the front of an assembled upright unit. A friend is recommended to assist with assembly as this will ease the process. Some of the parts are large and awkward to hold in place, an extra pair of hands will help.

Parts List Model 51538

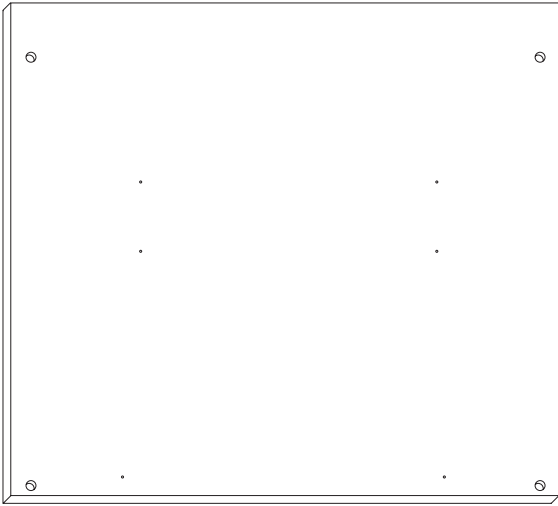

Back Panel (1)
P/N BP-51538

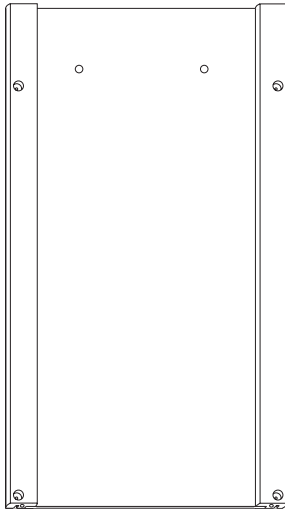

Side Panel (2)
P/N SP/HDL-51538

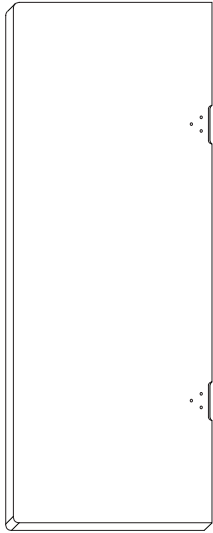

Drop Leaf (1)
P/N DL-51538

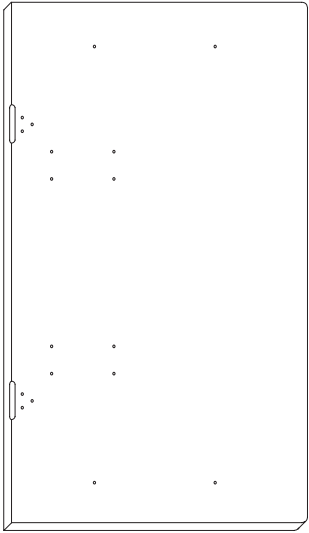
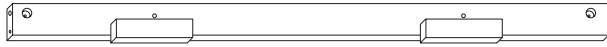

Table Top (1)
P/N TT-51538



Glide Support (2)
P/N GLDSUP-51538



Top Front Brace (1)
P/N B-34 1/4 / 2 1/2/TF-51538

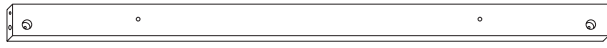

Bottom Front Brace (1)
P/N B-34 1/4 / 2 1/2/BOT-51538



Drawer Front (1)
P/N DF-51538

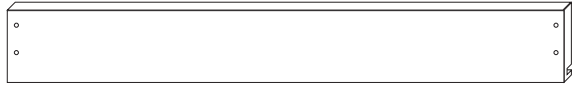

Drawer Back (1)
P/N DBK-51538

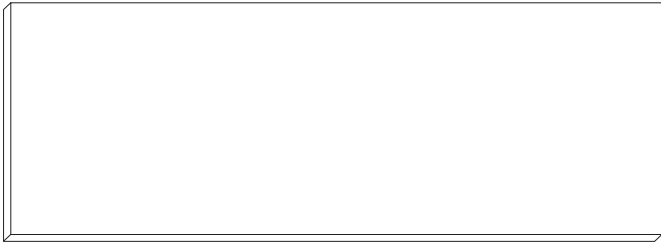

Center Shelf (1)
P/N CS-51538

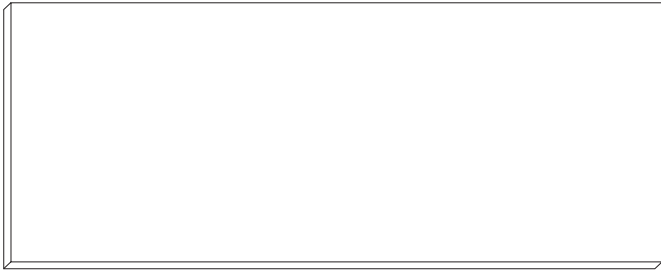

Bottom Shelf (1)
P/N BS-51538



Drawer Bottom (1)
P/N DB-51538



Left Drawer Side (1)
P/N DS-51538L



Right Drawer Side (1)

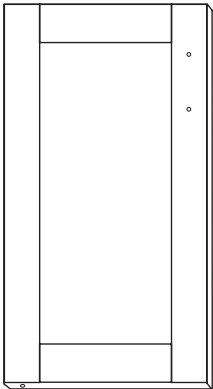

Left Door (2)

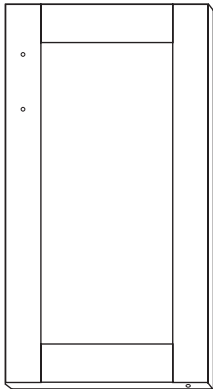

Right Door (2)

Hardware 51538

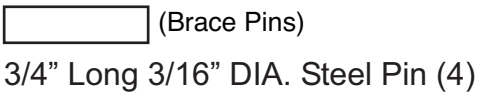
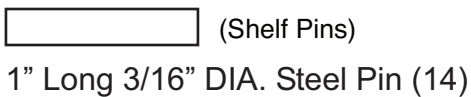
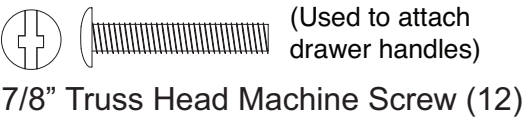
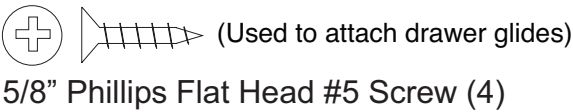
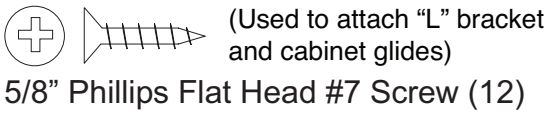
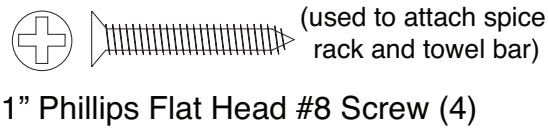
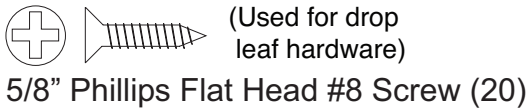
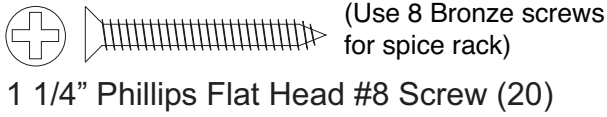

Magnet Packs (4)

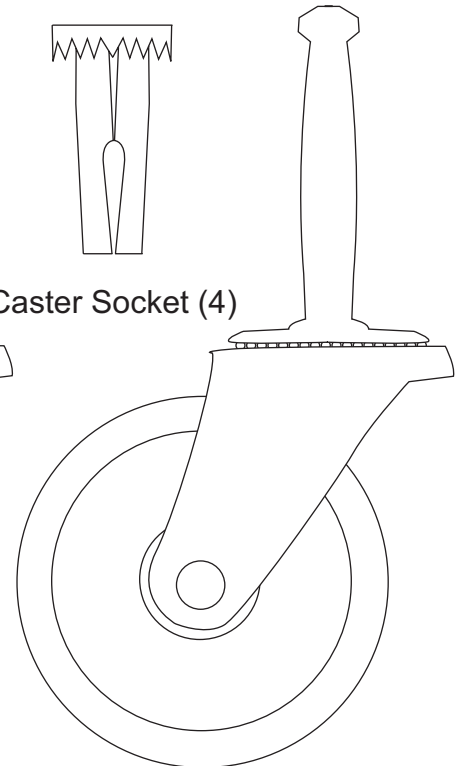
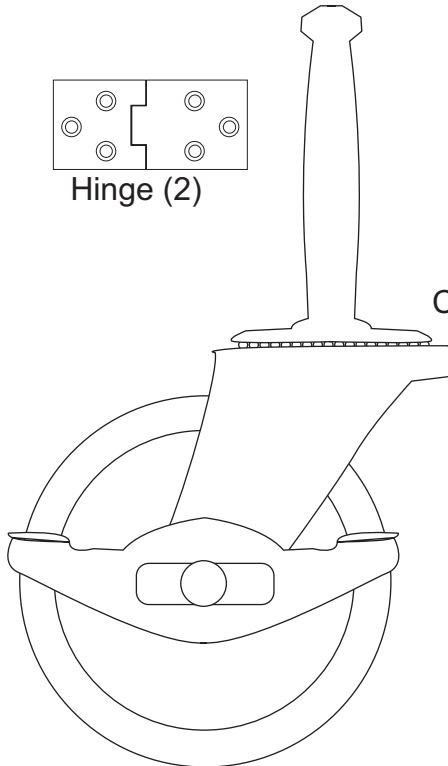
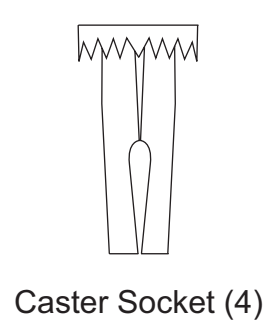
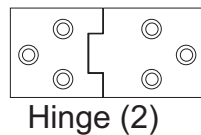
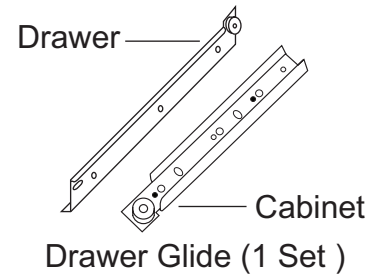
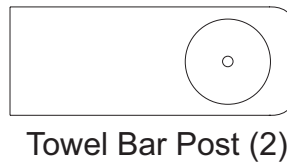
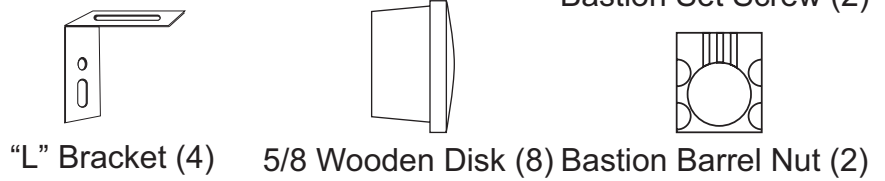
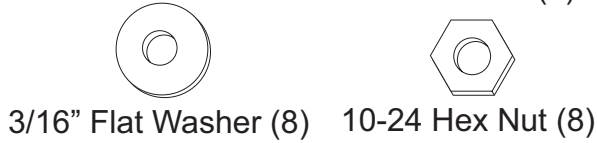
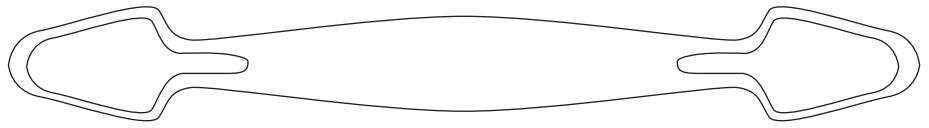
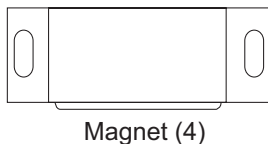

STEP 1

A. Tap/insert ONE 1 1/2" pin into each end of all the doors. DON'T OVERDRIVE PINS! Pins should stick up about 1/2" when seated.

B. Attach the magnet plate (may be stuck to magnet!) with the 1/2" #4 screw to the top of the doors. Bumps go toward the wood.

C. Attach door handles with 7/8" truss head machine screws.

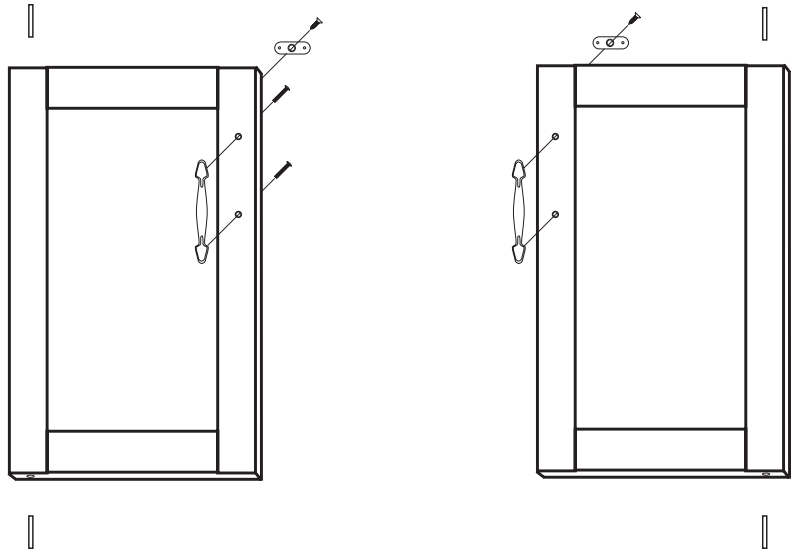

STEP 2

A. Take the 2 front braces and tap/insert one 3/4" steel pin into each end of both braces until seated. About 3/8" will stick out when seated. OK if loose.

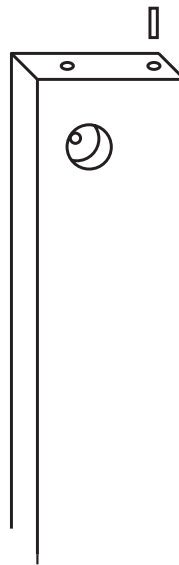

STEP 3

Assemble Spice Rack

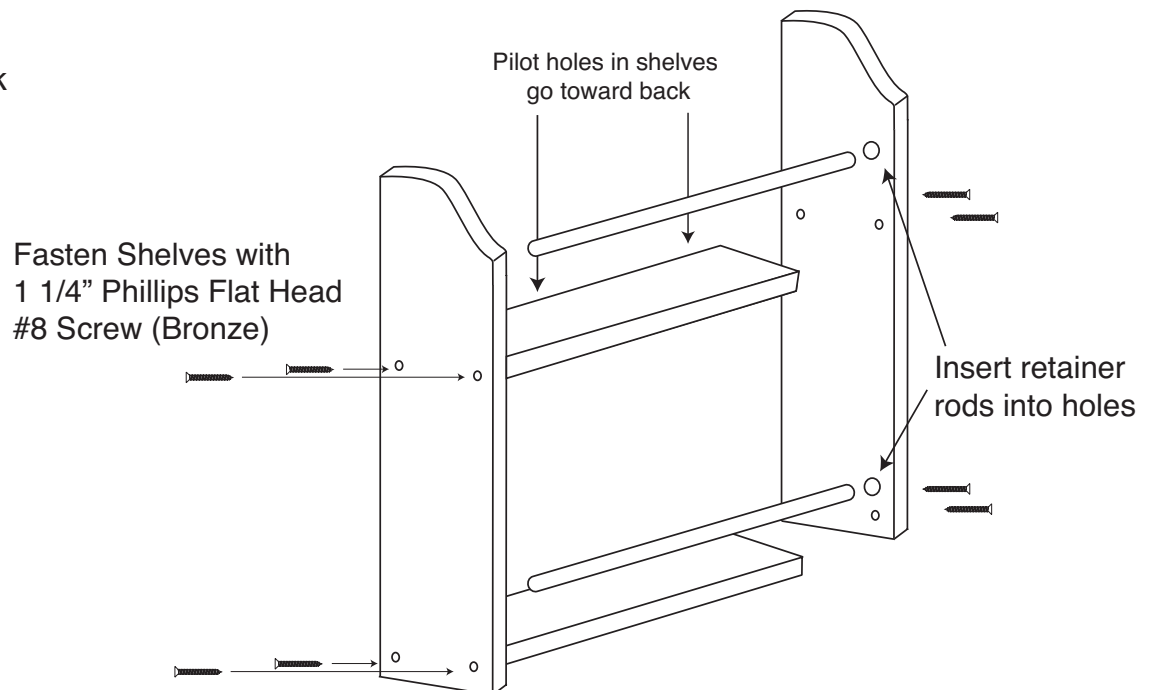

STEP 4

A. Attach the Drawer Back to the Drawer Sides with four 1 1/4" #8 screws. There are left and right sides. Make sure the slots that run the length of the Sides are aligned with the slot in the Drawer Back to accept the Drawer Bottom.

B. Slide in Drawer Bottom, best side up, to inside of drawer.

C. Take the 2 bastion posts, align the threaded end of the posts with the post holes located near the ends of the inside of the Drawer Front. Tighten posts down until the solid shaft of the posts hits the wood. Back post out until the hole/screwdriver slot in end of post is parallel and in direct line with the long edges of the Drawer Front.

D. Insert the barrel nuts into the nut access holes on the inside of the Drawer Sides with the threaded ends of the nuts facing out. Take the Drawer Front and carefully insert the posts into the ends of the Drawer Sides, through the sides of the nuts until seated. Push nut snug up against the wood in the nut access hole toward the inside of Drawer Front. Hole should be slightly off-center toward the Drawer Front. Insert the set screw and tighten down. The ends of the sides should be tight against the inside Drawer Front.

E. Attach the drawer handles with 7/8" Truss head machine screws.

F. Attach the drawer glides (left and right) to the Drawer Sides using two 5/8" #5 screws per side. Wheels go toward Drawer Back and are up. The end with no wheels should touch the Drawer Front.

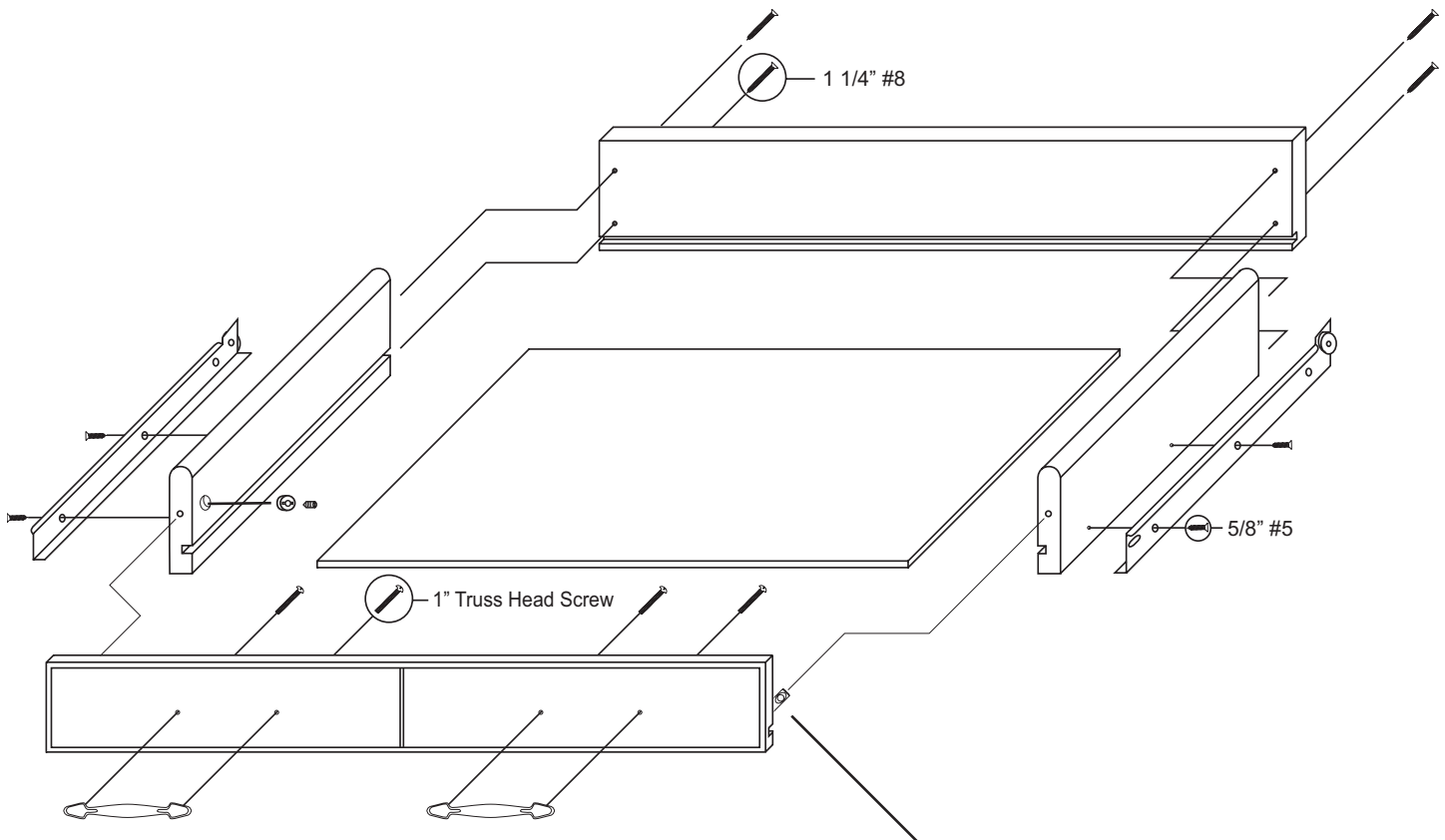

See next page to learn how the bastion fastening system works.
Also see our video on the Bastion Fastening System at www.catskillcraftsmen.com

TIPS ON HOW THE BASTION FASTENING SYSTEM WORKS

1. The Bastion fastening system consists of a steel post (threaded on one end with a hole through the shaft on the other end); a Barrel Nut (cylindrical barrel-shaped with threaded open end & holes through the sides); and a Set Screw (Phillips slot on one end, pointed on the other)

2. To attach Posts: A) Dip threads of Post in vegetable oil. B) Align threaded end of Post with hole in wood, tap on slotted end with hard hammer until threads enter, then tighten down using a flat head screw driver or the provided allen wrench (See the Illus. Bas. 3 for alternate seating methods). **DO NOT TRY TO HAMMER THE POST ALL THE WAY IN AS IT WILL STRIP THE POST HOLE.** C) When solid shaft of Post hits wood, back out approximately ½ turn until the hole in the posts is properly aligned as per step by step directions. For example: the holes in the posts on the inside of the drawer front will be parallel with the long length of the drawer front when properly seated.

3. A) Place a Barrel Nut into the nut access hole, so that the threads in the nut face out. The small notches on either side of the nut opening, indicate the location of the holes through the sides of the nut. B) Insert the posts through the end of the braces (or drawer sides); through the holes in the sides of the nut. When properly aligned, you will see the hole in the post inside the barrel nut. Post hole should be slightly off-center toward the wood.

4. Insert the Set Screw into the threaded end of the nut and tighten down. The tip of the Set Screw will seek the center of the hole in the Post as it is tightened down, forcing the Nut toward the main shaft of the Post. This is what tightens the wooden parts together. Set screws should thread easily – **DON'T CROSS THREAD!** If Set Screw doesn't thread easily, check position of the hole in Post.

5. If the wooden parts are not tight against each other, the Post needs to be screwed a half turn at a time until wood joints are tight.

Illustration Bas. 1

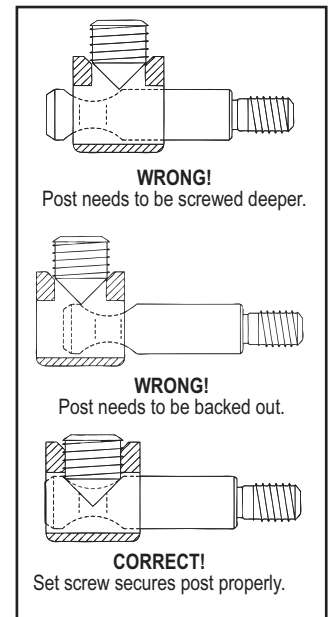
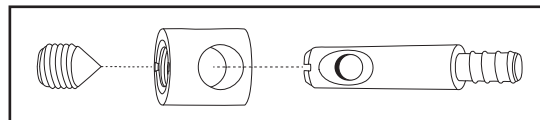
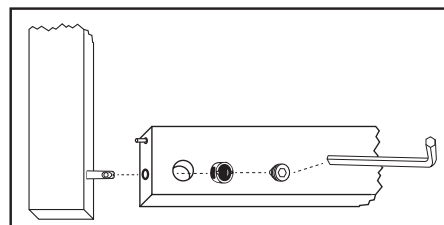

Illustration Bas. 2



Step 2



Allen Wrench Provided

Step 1

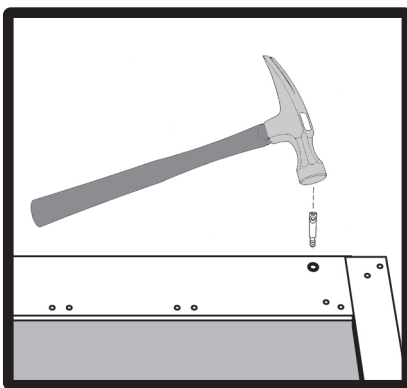
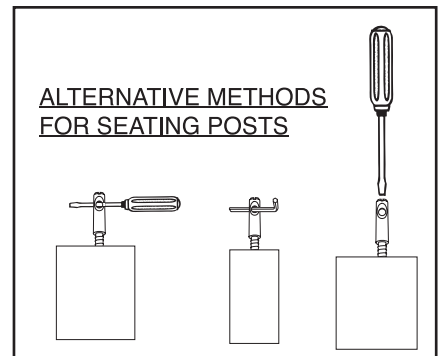

Illustration Bas. 3



See video on our website!

If you have any questions regarding assembly or missing or damage parts, call our customer support number:

607-652-7321 or 888-732-7321.

STEP 5

A. Attach a Glide Support Stick to the top of each Side Panel using 1 1/4" #8 screws. The countersunk holes (reamed out) in the stick are positioned as in illustration 5 so that the glide holes are toward the lower edge. Sticks should be flush with top of panel.

B. Attach the cabinet glide of the Drawer Glides to the Glide Support Stick using 5/8" #7 flat head screws. Left glide to left Side Panel, right glide to right Side Panel. The glides look almost alike however, the right glide (as you face the cart) has a rolled lip at the top of the glide that keeps the drawer glide wheel in place. Line up the holes in the glides so that the end with the wheel comes flush with the front edge of the Glide Support Stick. Only 2 pilot holes are used in the glide support sticks.

C. Attach the "L" brackets to the top of the glide supports using 5/8" #7 screws. Use the slot rather than the hole. The hole will be used to attach the table top. The "L" brackets should be flush with the top of the glide support sticks.

Note: Cabinet drawer glides usually have an imprint "CL" or "CR" inside near the wheel.

CR=Right / CL=Left

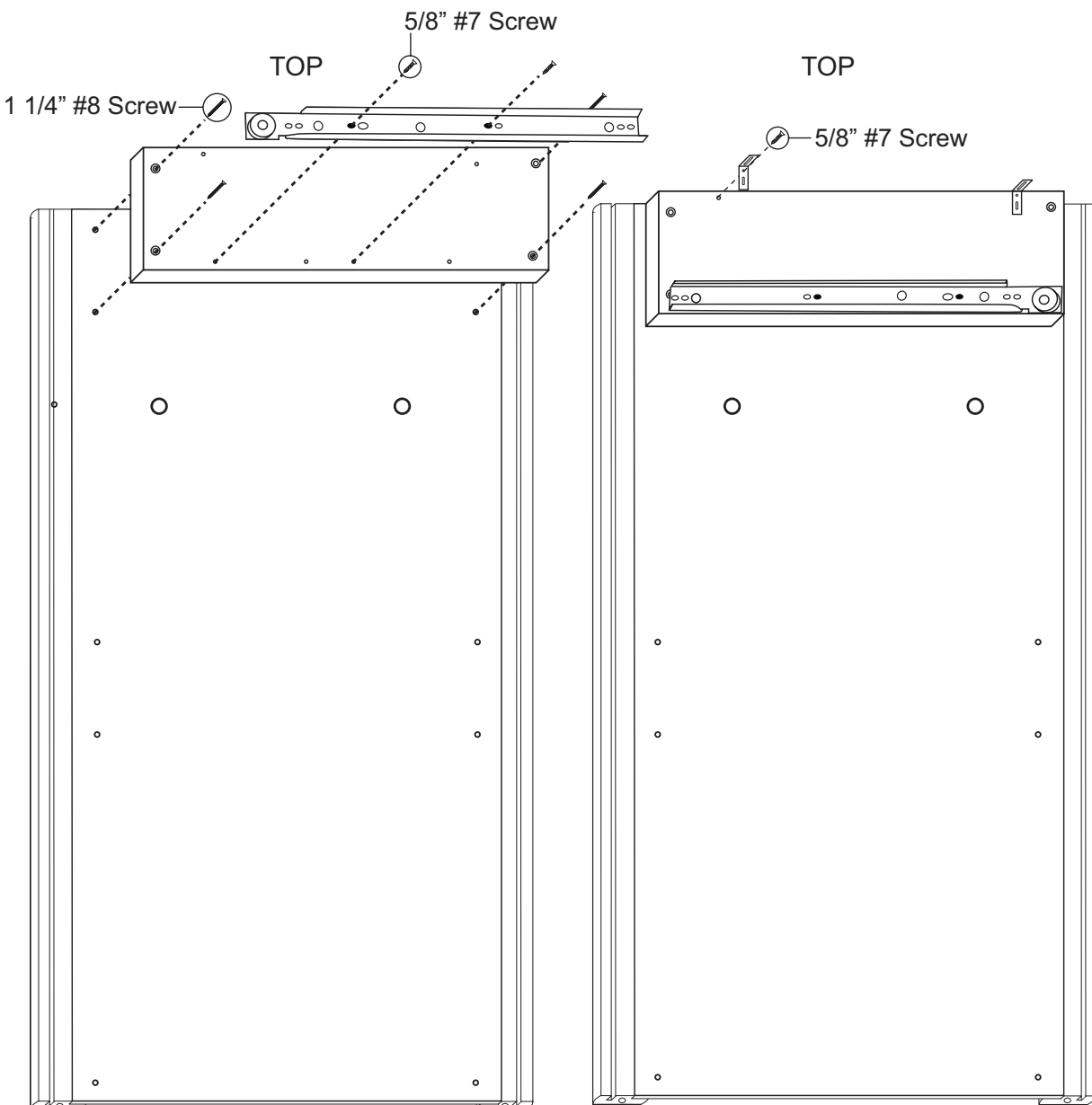

STEP 6

- A. Lay Back Panel flat on a smooth surface with holes up.
- B. Attach Side Panels with 1 3/4" bolts and hex nuts. After inserting bolts(s) thru the holes in the Side Panels, thru the holes in the long edges of the Back Panel, place a hex nut on the tip of your finger, align nut with bolt and tighten.
- C. Look ahead to step 7 which shows side panels attached to back panel.

NOTE: Make sure you position the side panels according to Drawer Glides (left or right). The Back Panel is 1 1/4" shorter than the Side Panels at the top.

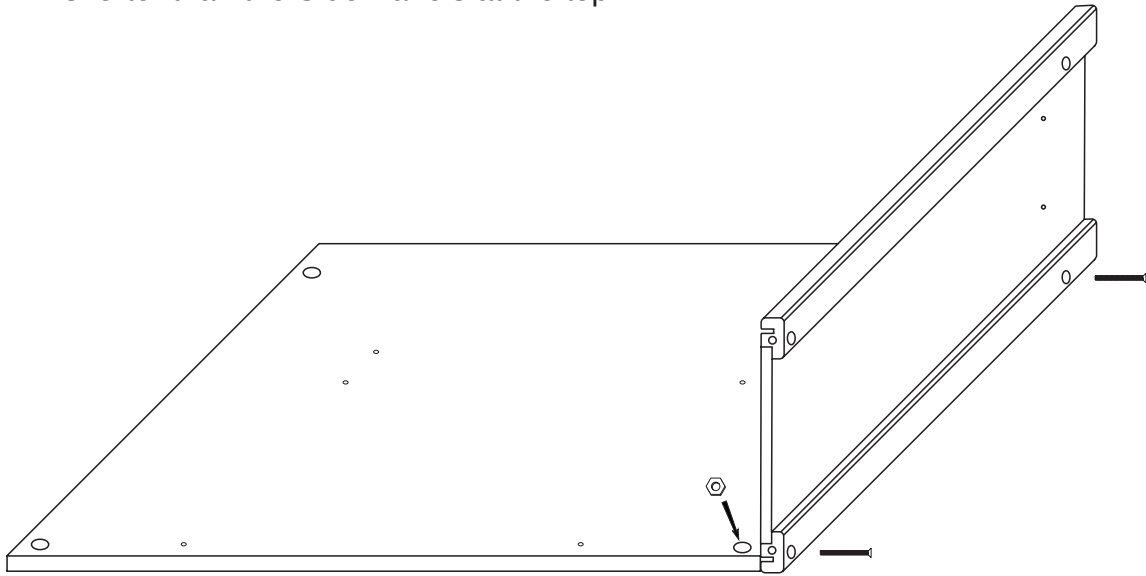

STEP 7

- A. Invert cabinet assembly from step 6.
- B. Take the Top Front Brace (with magnet blocks), insert the pins in the brace ends into the slots on the inside of the front legs of the Side Panel and slide down until the brace is aligned with the set of holes in the Side Panel as illustrated.
- C. Secure brace with 1 3/4" bolts and hex nuts as in step 6

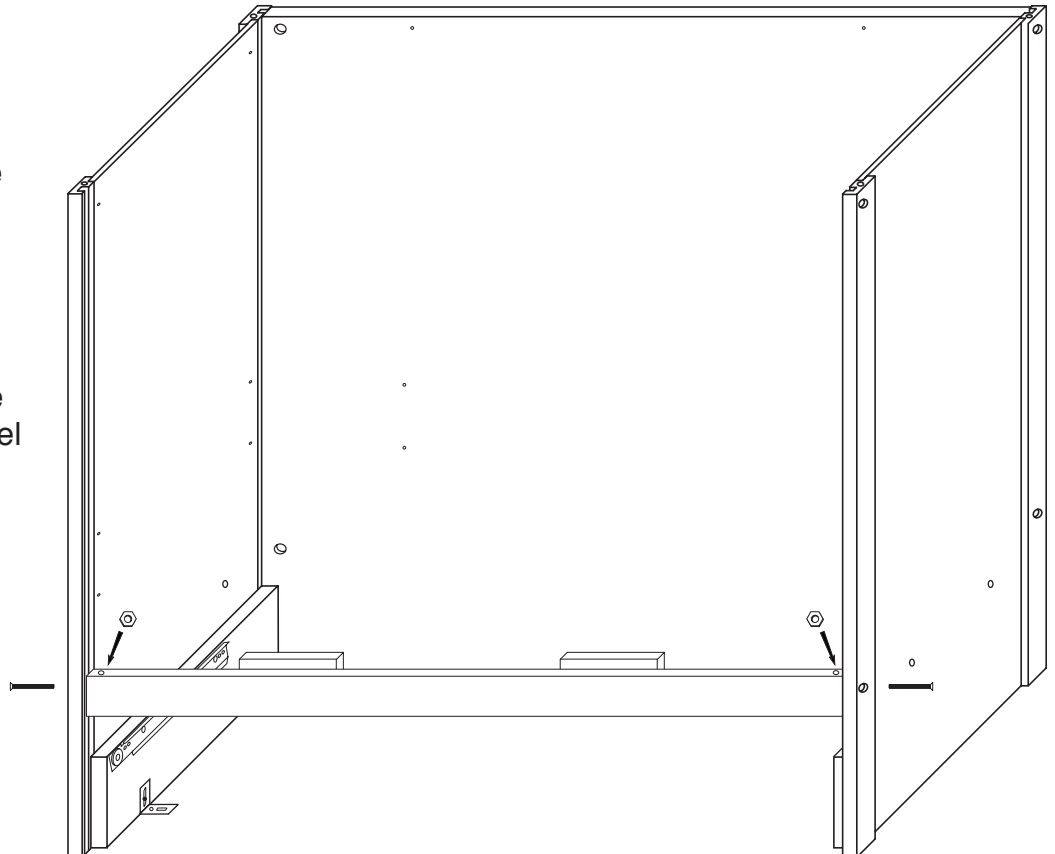

STEP 8

A. Install Doors by fitting the pins in the top of the door into the holes in the Top Front Brace.

B. Place washers on the pins on the bottom of the doors, then fit the Bottom Front Brace onto the pins and secure the brace using 1 3/4" bolts and nuts as in illustration 8A.

C. Tap two 1" pins into the back panel, two into the holes on the inside of the Bottom Front Brace and two into each Side Panel as in illustration 8B. These will hold the Bottom Shelf.

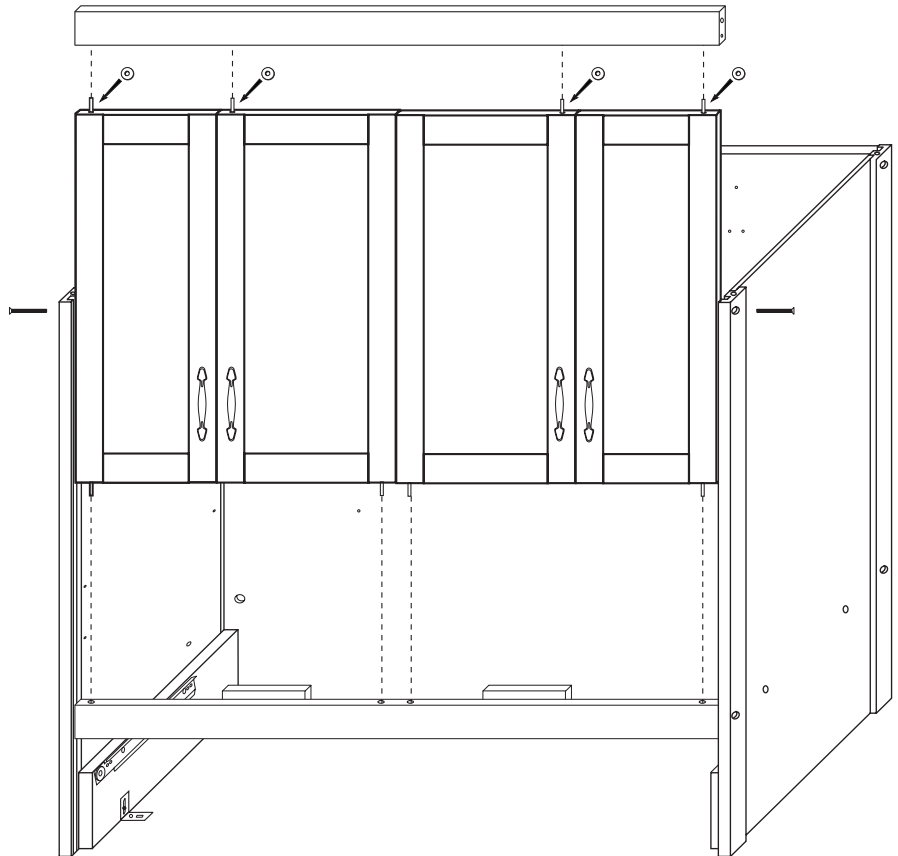

ILLUSTRATION 8A

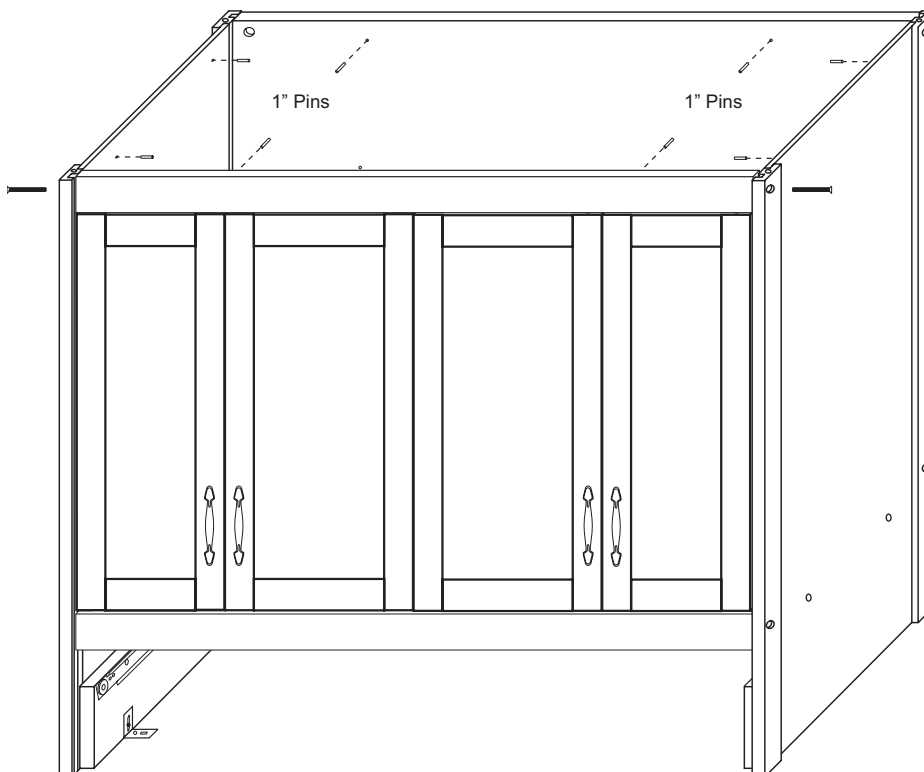
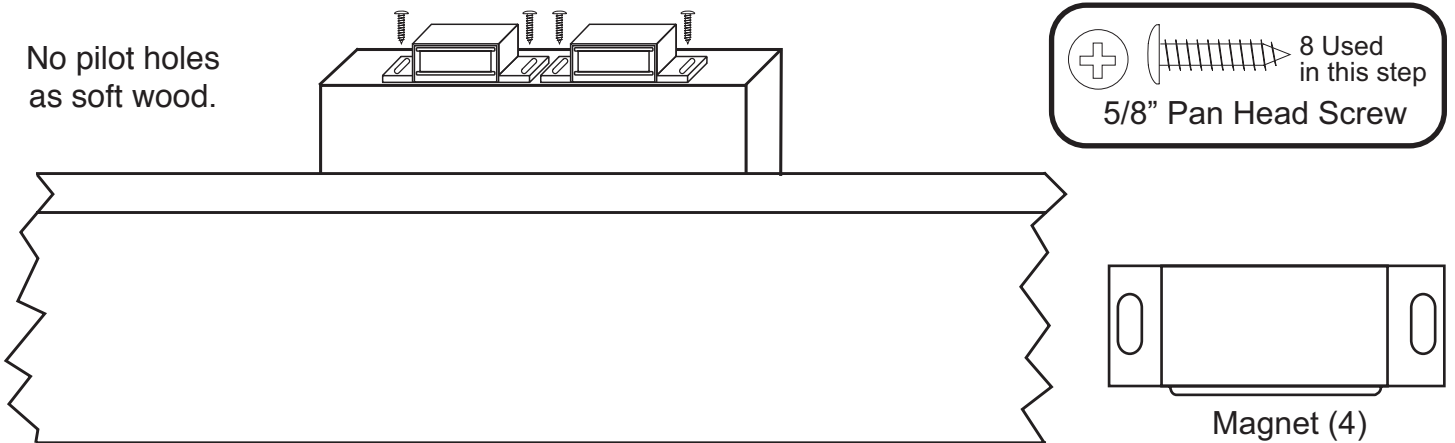

ILLUSTRATION 8B

STEP 9

- A. Stick magnet to magnet plate on an outside door.
- B. With adjacent door open, close the outside door. The magnet should be positioned over the wooden block on the bottom of the top front brace. Hold the magnet in place with your thumb, and open the door. The magnet will be in the correct position on the block. Mark the position with a pencil.
- C. Secure magnet with the two round head screws in the magnet packet. Center screws in the slot in the magnet. This will allow adjustment later, if needed.
- D. Repeat these steps for all the doors.



STEP 10

- A. Insert and tap caster sockets with hammer until the teeth grab the wood. **DON'T POUND SOCKET FLAT OR CASTER SHAFT WILL NOT ENTER.**
- B. Insert casters and seat by pushing straight downward with heel of your hand, or tap into place with a hammer. Don't be afraid to give them a good downward whack on the solid metal part of the caster!
- C. Locking wheels usually go on front.

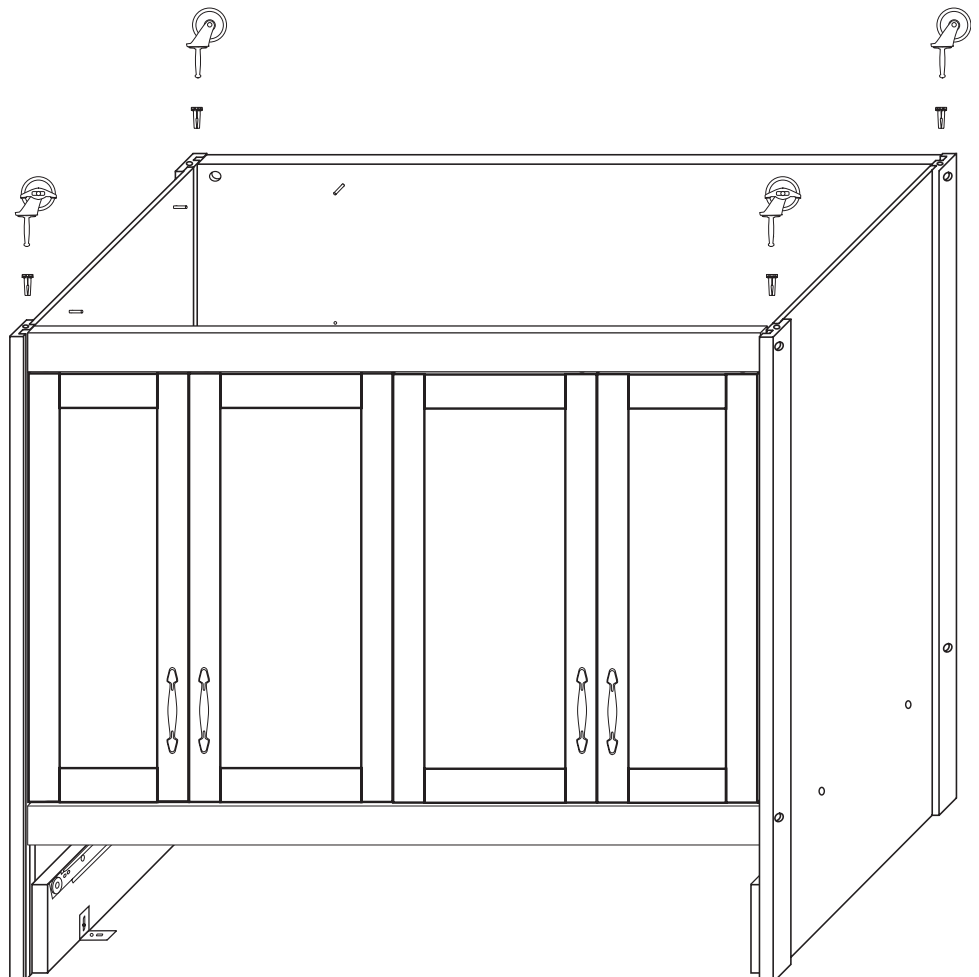

STEP 11

Upright unit. Decide which side to put the spice rack on then put the towel bar on the other side. Attach side handle/towel bar using 1" Phillips Flat Head #8 screws. Place a washer over the screw to keep screw heads from pulling through the side panels. Attach the spice rack in the same way using the pilot holes in the top shelf. The holes in the bottom shelf are not used.

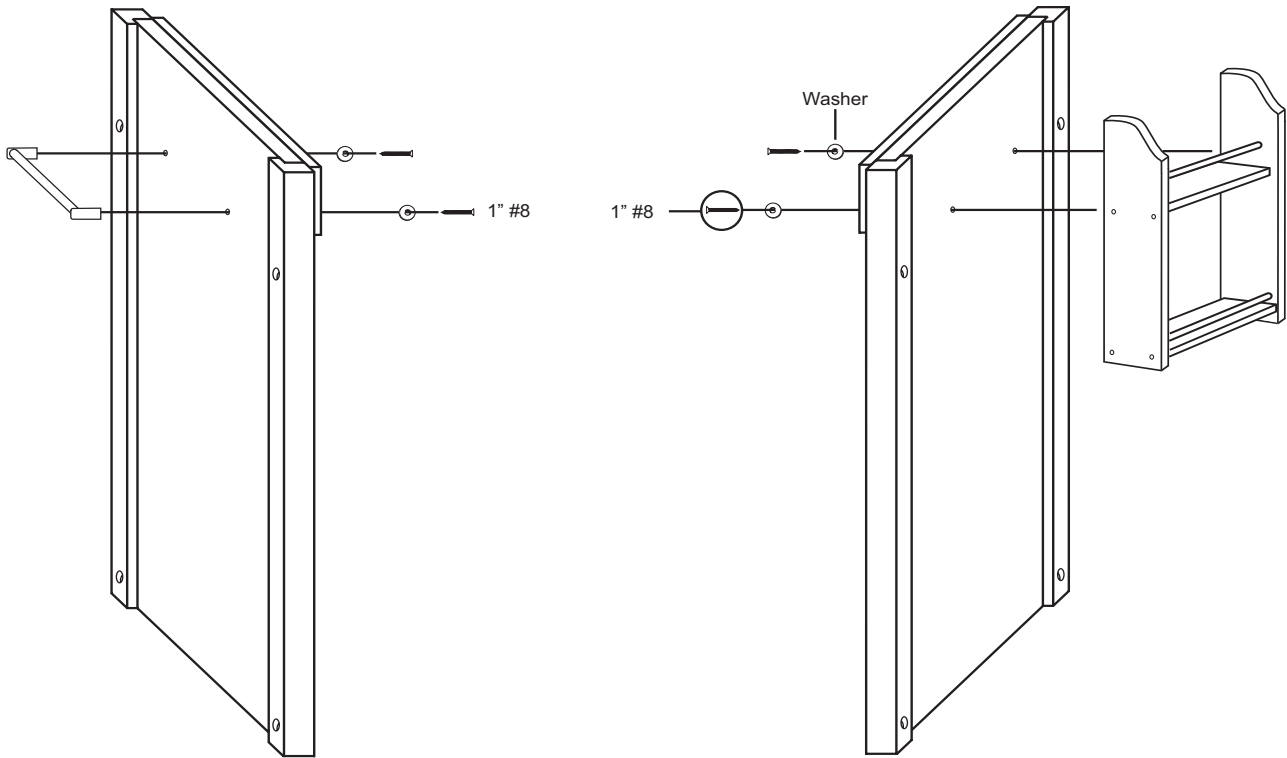

STEP 12

A. Angle the bottom shelf as necessary to pass it through the opening in the cabinet top until it rests on the pins installed in step 8.

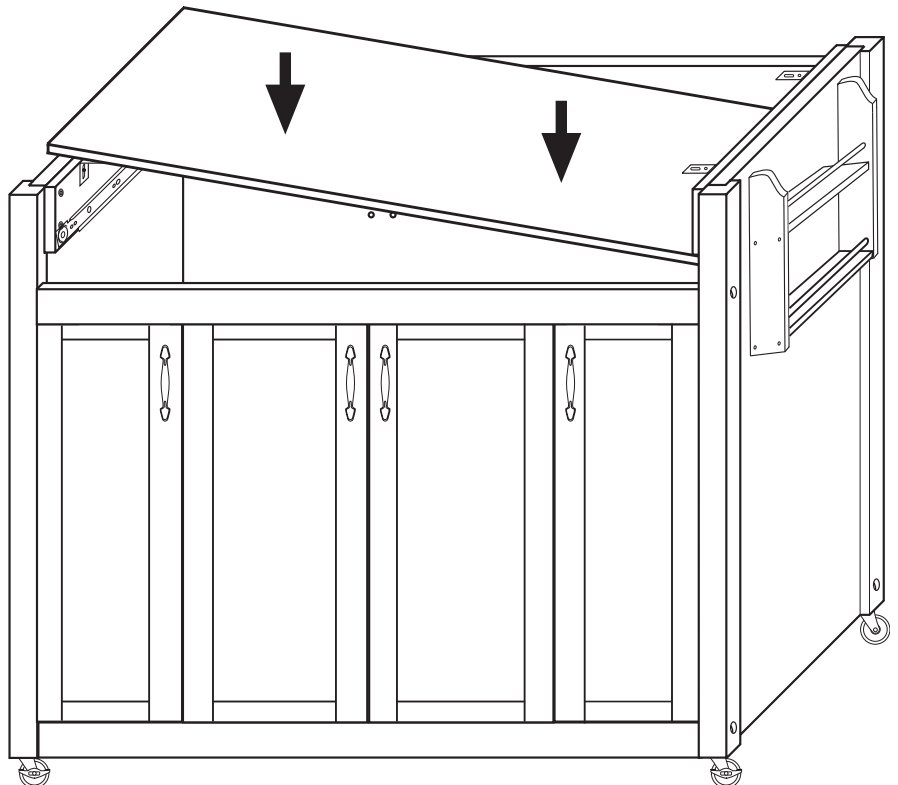

STEP 13

A. Set the height for the middle shelf by choosing one of two sets of holes in the Back & Side Panels. Then tap 1" pins into the 6 holes in the Back & Side Panels.

B. Fit the middle shelf into the cart and rest it on the pins.

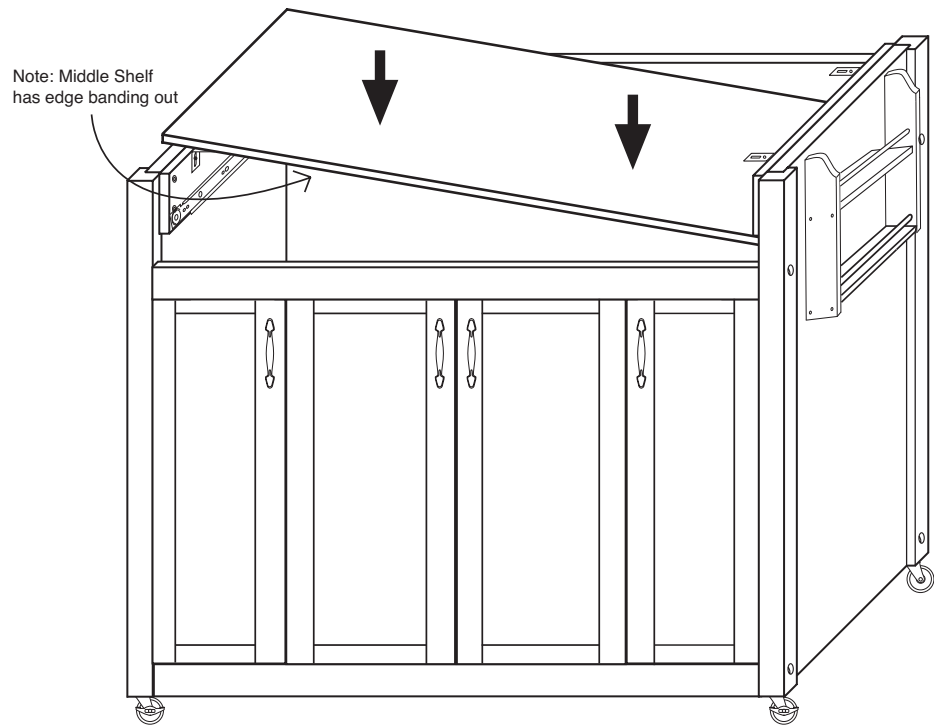

STEP 14

A. Assemble top by placing the top and the drop leaf upside down on a smooth flat surface. Install hinges using 5/8 #8 screws. The longer part of the hinge goes on the drop leaf with the short part on the cart top. Fasten the drop leaf supports using 5/8 #8 screws. See illustration 14B.

B. Make a large X mark over each of the 4 pilot holes in the bottom. Make marks about 1/2-1" long. These marks will help you align the cabinet with the pilot holes in the bottom of the Top.

C. Place the Cart Top on the cabinet. Open the outside doors. Maneuver the Cart Top so that the X marks/pilot holes in the bottom of the Top align with the holes in the "L" brackets. Secure top to "L" brackets with 5/8" #7 screws.

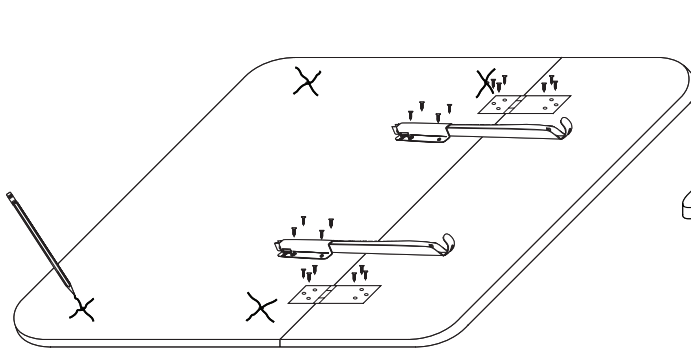

ILLUSTRATION 14A

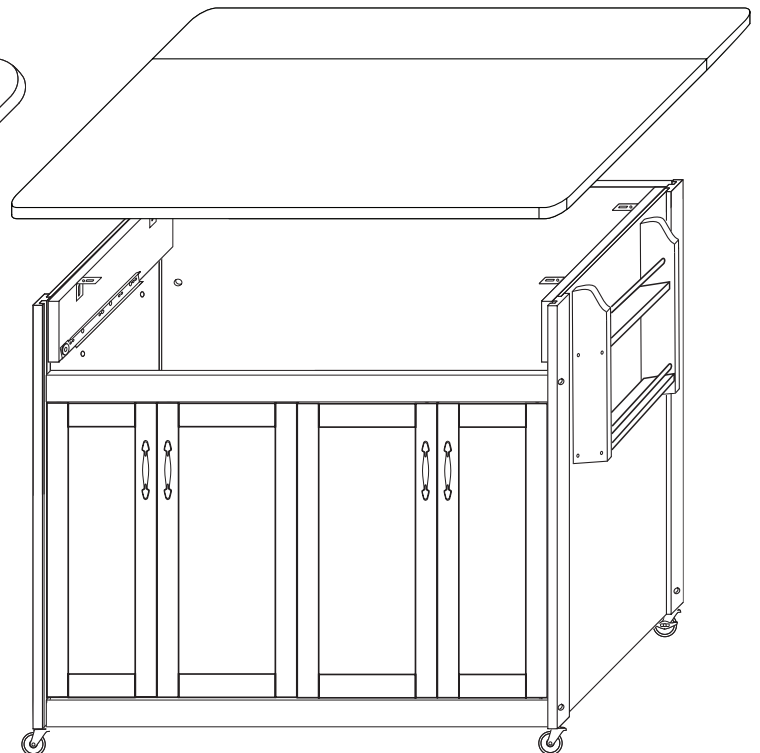

ILLUSTRATION 14B

STEP 15

- A. Slide the Drawer into the front of the cart. Make sure drawer slides smoothly, then retighten all bolts and nuts.
- B. Tap in the 5/8 wooden plugs into the holes on the legs.
- C. Illustration 15B shows completed 51538.

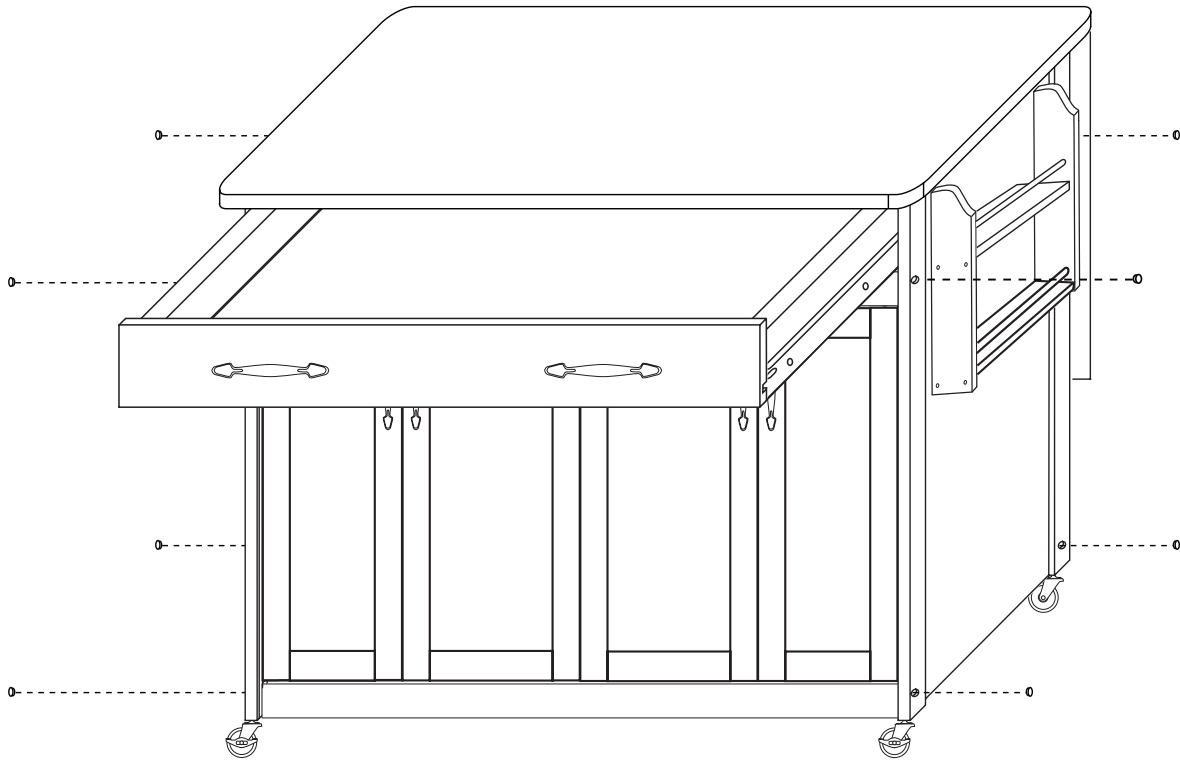

ILLUSTRATION 15A

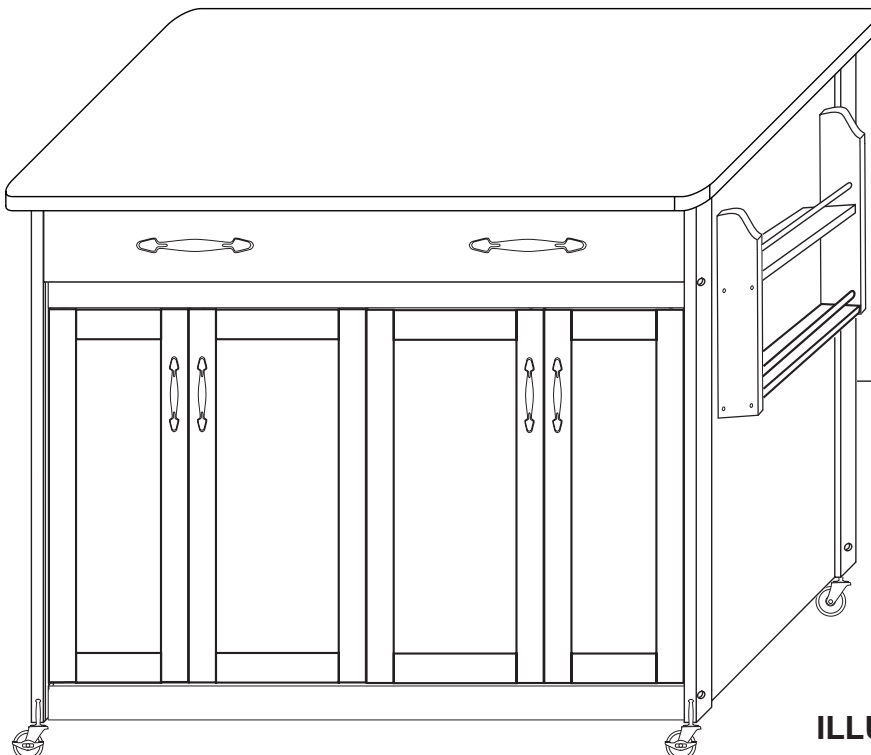

ILLUSTRATION 15B



For continued beauty and long life of your Catskill Craftsmen cart, we recommend Catskill Craftsmen's Butcher Block Oil.

Our Butcher Block Oil is available directly from Catskill Craftsmen's factory. For one eight ounce (8 fl. oz.) bottle, which is sufficient for two applications, simply send \$6.95 along with the completed coupon to the address below. Visit us online at www.catskillcraftsmen.com to browse our assortment of butcher block care products. Visa and Mastercard are accepted online .



Catskill Craftsmen, Inc.
15 West End Ave.
Stamford, NY 12167-1296



BUTCHER BLOCK OIL COUPON

Please send me _____ # of bottle(s) of the Catskill Craftsmen Butcher Block Oil at \$6.95 per bottle. My check or money order is enclosed for a total of \$_____.

Item code: 51538

Name _____

Address _____

City _____

State _____ Zip _____

Please make checks payable to Catskill Craftsmen Inc. 15 West End Ave., Stamford, NY 12167-1296