

# Assembly instructions

**Warnings: You must read this before you proceed.**

## **VIRGINIA CAST BENCH**







**CAUTION :** This bench is NOT a TOY. Keep your child / children at bay in the process of assembly.

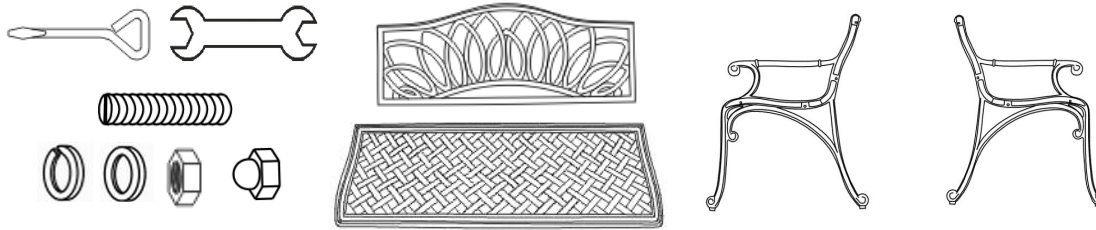

## Assembly Preparation

Before Beginning Assembly:





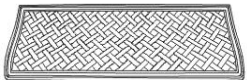



-  • Read instructions, cover to cover-
-  • Have 2 adults on hand for assembly-
-  • Do not assemble on flooring or carpet-
-  • Assemble on a clean non-marring surface (packing foam)-
-  • Save all packaging until finished-

### Parts list

NO.	Picture	Description	QTY
A		Backrest Panel	1
B		Chair Seat Panel	1
C		Right Arm with pre-attached Leg Levellers	1
D		Left Arm with pre-attached Leg Levellers.	1

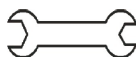
### Hard ware

E		Studs(8*30mm)	9
F		Washers(8mm)	9
		Spring Washers(8mm)	9
		Nuts(8mm)	9
G		Caps	9
H		Spanner	1
I		Screwdriver	1

## Assembly Step

### Step 1

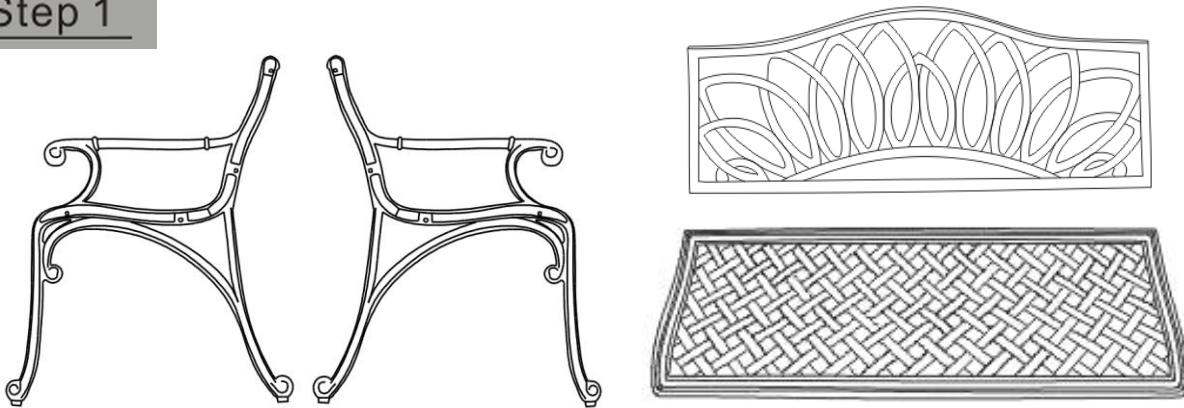

Unpack and place all parts on a clean soft surface.

### Step 2

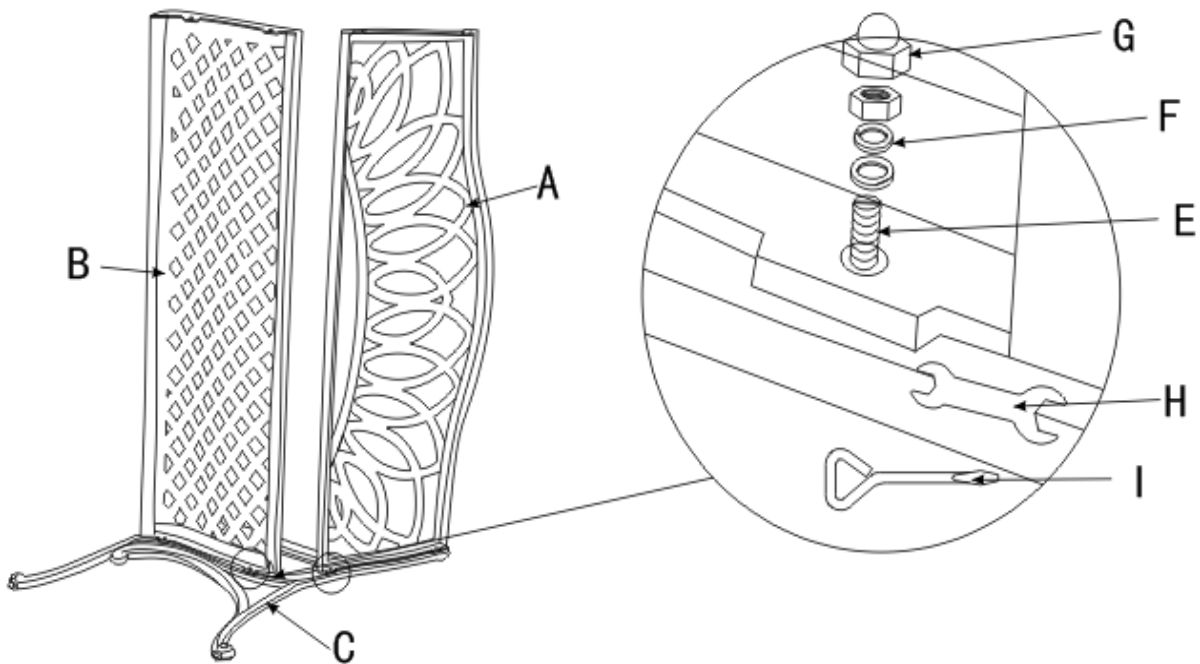

Place the Left Arm flat on the ground.

Fix the Studs (E) to the contact points on the Right arm (C) using the Screwdriver (I).

Then attach the Chair Seat Panel (B) and Backrest Panel (A) to the Right arm (C) using Caps (G), Nuts, Spring Washers and Washers (F) with the Spanner (H).

**DO NOT OVERTIGHTEN, yet.**

### Step 3

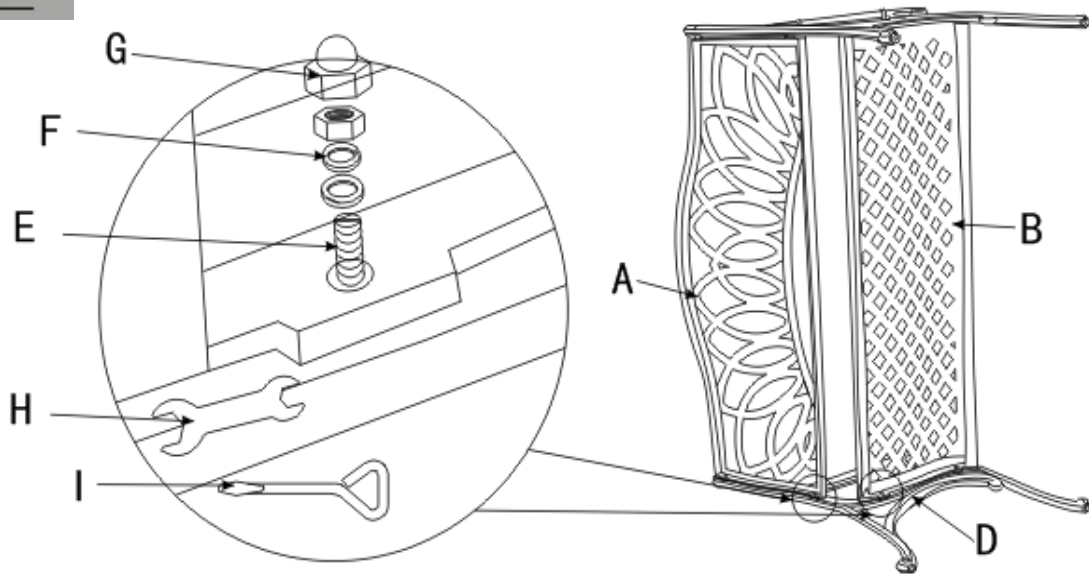

Fix the Studs (E) to the contact points on the Left arm (D) using the Screwdriver (I).

Attach the Left arm(D) to the Chair Seat Panel(B) using Caps(G) , Nuts, Spring Washers and Washers(F).

Then to the Backrest Panel(A) using Caps(G) , Nuts, Spring Washers and Washers(F).

Hold all parts tightly during the assembly process,2 persons may be needed to execute this action.

**DO NOT OVERTIGHTEN, yet.**

### Step 4

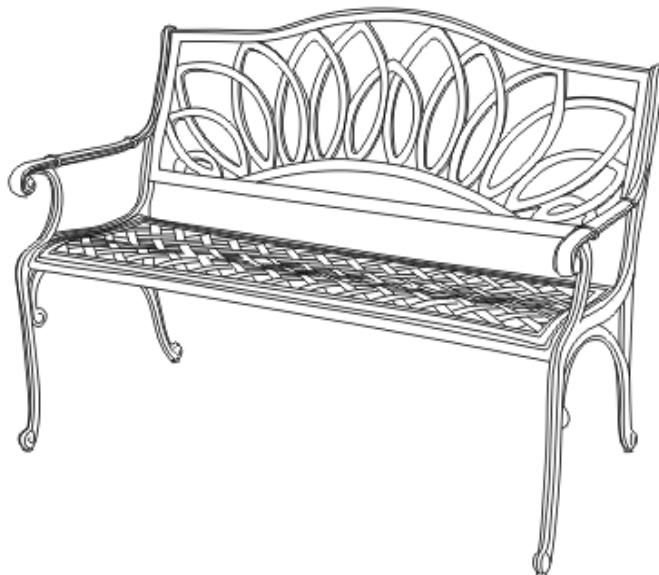

Turn the Bench rightside.

Adjust the pre-installed Rubber Caps until the bench is level with the ground.

Now, proceed to **FULLY TIGHTEN** all screws and bolts.

Your Bench is ready for use.

## Care & Maintenance

### Care & Maintenance

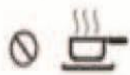

● Do not put **HOT** items directly on furniture surface.



● Do not clean furniture with **HARSH** cleansers or polish.

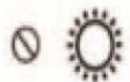

● To prolong product lifetime, **AVOID** placing furniture under direct sunlight.



● Do not place furniture near **heating or cooling** vents.

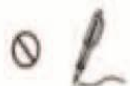

● Do not write on furniture without a padded barrier to protect the surface.



● To prolong the product lifetime, avoid extended and lengthy exposure to rain and sunshine. Where possible, place under covers and or patio and or awnings.



● For residential use only. Not for commercial use.



● Stains may be removed with mild soap solution and damp cloth.



● Dust and pick-up spills using a clean, non-colored, lint-free cloth.