

LATCH EDITION - SECURE | SECURE PLUS | SECURE PRO

**LOCKLY™ SECURE**



**INSTALLATION MANUAL**



For an online version of this installation guide and videos, visit:

**<http://lockly.com/help>**

# INSTALLATION OVERVIEW & PARTS LIST

This lock can be installed for both right swing and left swing doors. The lock ships ready for a right swing door installation. If you wish to change the orientation of the lock for a Left Swing door, go to **Step 3** for instructions.

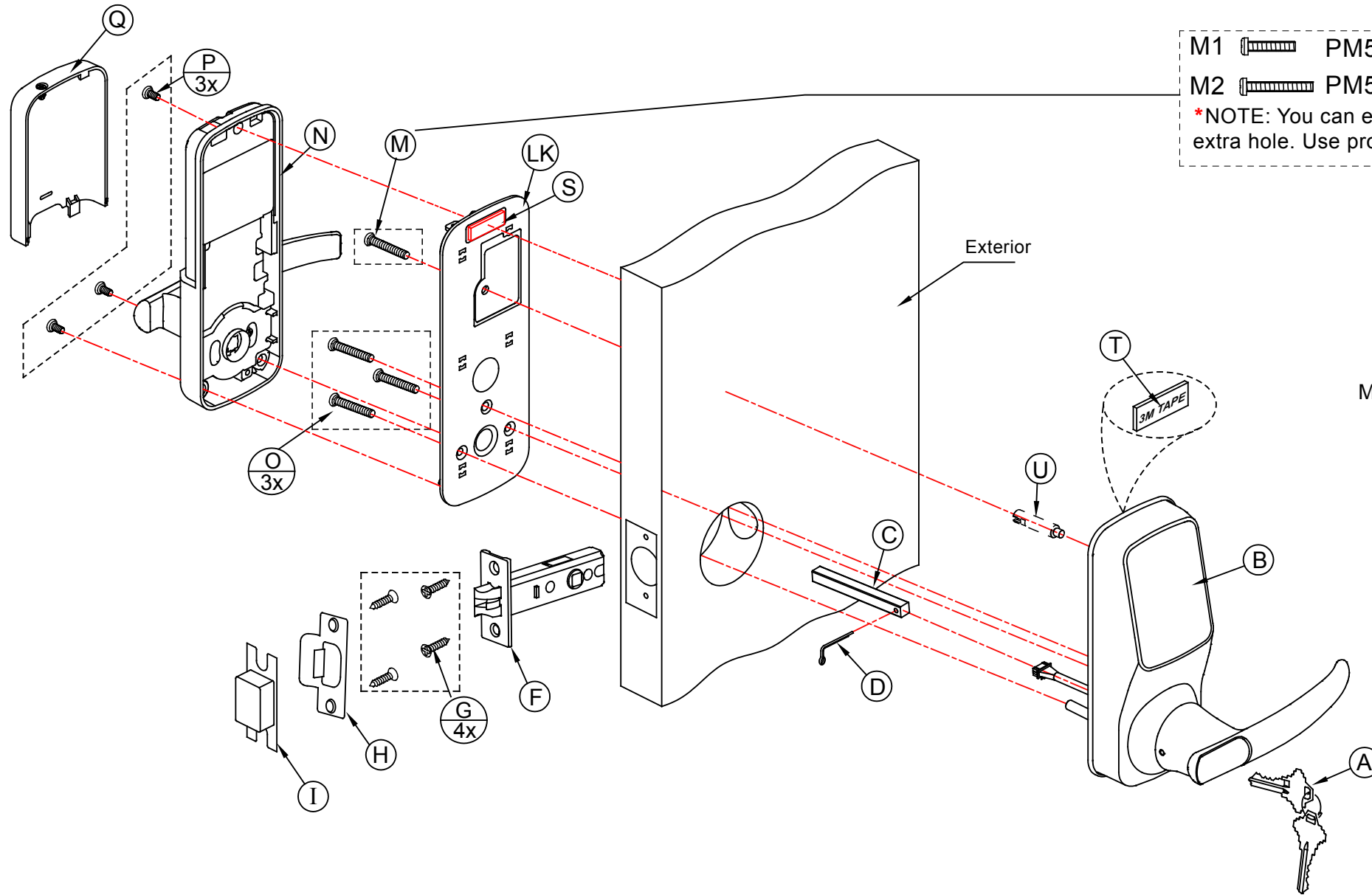

M1 PM5X25mm, Door thickness 1-19/50"~1-69/100"(35~43mm)  
 M2 PM5X35mm, Door thickness 1-69/100"~1-97/100"(43~50mm)  
 \*NOTE: You can either use T or U to stabilize the exterior part. U requires drilling an extra hole. Use provided Template for drilling instructions if needed.

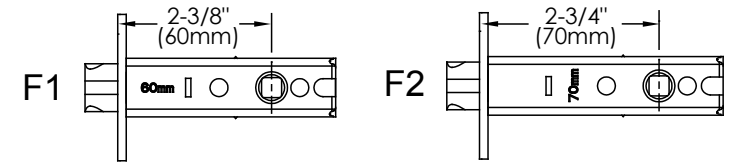

Measure distance between the center of the hole to the edge of door:  
 Use F1 if 2-3/8"(60mm) or F2 if 2-3/4"(70mm)

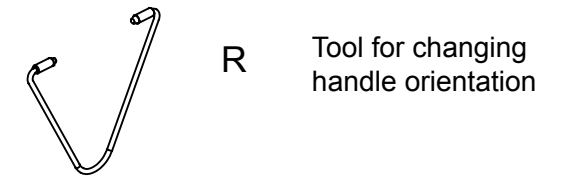

R Tool for changing handle orientation

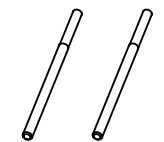

V 2x Positioning rods for installing part LK

## GETTING STARTED - YOU WILL NEED

All the parts you need to install the Lockly Secure Latch Edition is included in your package. However, we do need a few tools.

### Required Tools

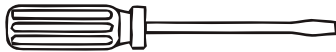

Flathead Screwdriver

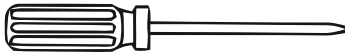

Phillips Screwdriver

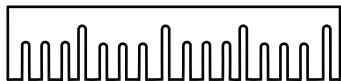

Ruler

### Optional

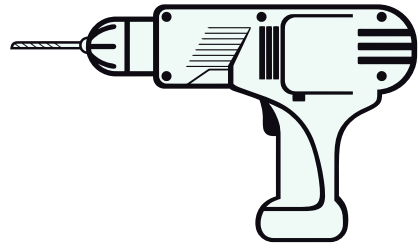

Screwdriver with drill bits

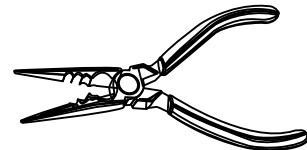

Pliers

*Drilling is not required to install the lock, and is optional. However if you are installing your lock on a brand new door, a drill is required if there are no holes prepared for lock installation.*

## STEP 1: PREPARING THE DOOR

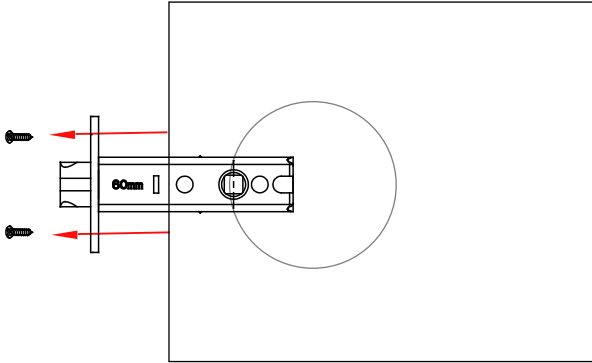

### 1.1

If you are installing the Lockly Secure smart lock on an existing door, please remove existing door hardware and latch or bolts before installing the new lock.

You can remove most existing door locks with a screwdriver.

*If you are having problems removing your existing door lock or unsure if what you are doing can damage the existing door, please contact a locksmith or the current door hardware manufacturer for assistance.*

### 1.2

After removing the existing lock, make sure your door is properly prepared. If you need to drill holes in your door, please use supplied templates to assist.

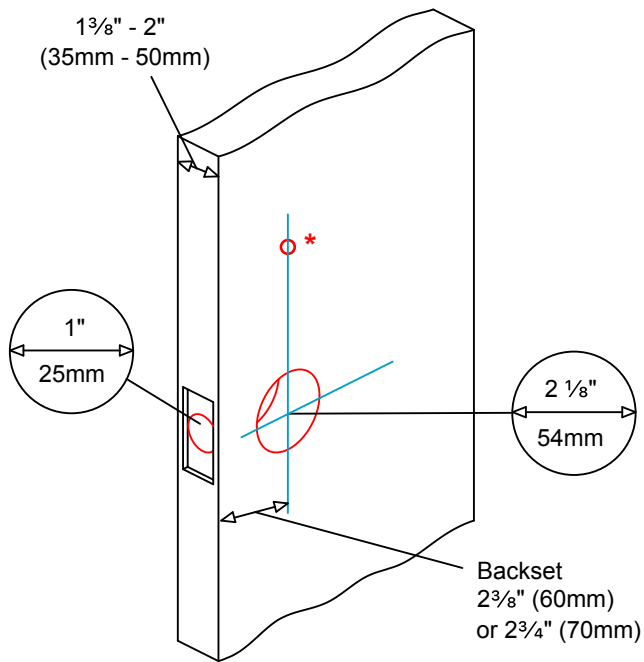

### 1.3

Measure and confirm your door is between  $1\frac{3}{8}$ " - 2" (35mm - 50mm).

### 1.4

Measure and confirm the hole in the door is  $2\frac{1}{8}$ " (54mm).

### 1.5

Measure and confirm that the backset is between  $2\frac{3}{8}$ " (60mm) to  $2\frac{3}{4}$ " (70mm).

### 1.6

Measure and confirm that hole in the door edge is 1" (25mm).

#### IMPORTANT NOTICE



\* You are not required to drill an extra hole on your door. We have provided 3M double sided tape for you to help stabilize the lock during installation. Only drill a hole if you wish to have added stability. Please refer to the provided template for drilling if needed.

## STEP 2: INSTALLING THE LOCKSET

**2.1** Measure the distance between center of front door hole to the edge of your door and select the correct lockset. Select F1 if 2-3/8"(60mm) or F2 if 2-3/4"(70mm).

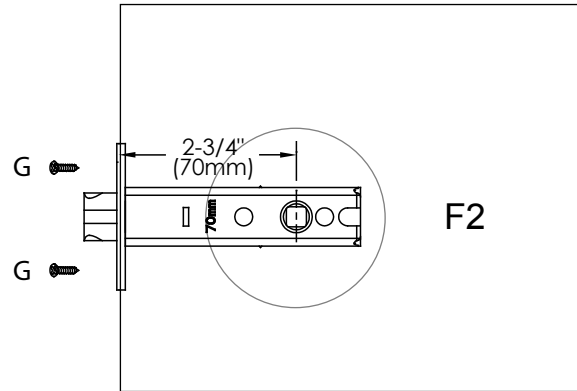
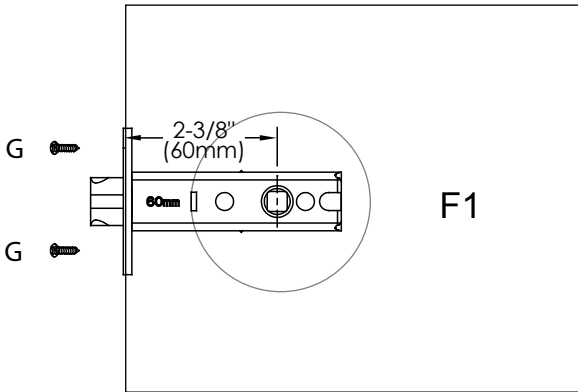

**2.2** Install the lockset with the slanted side of the latch facing towards the closing direction.

Example 1

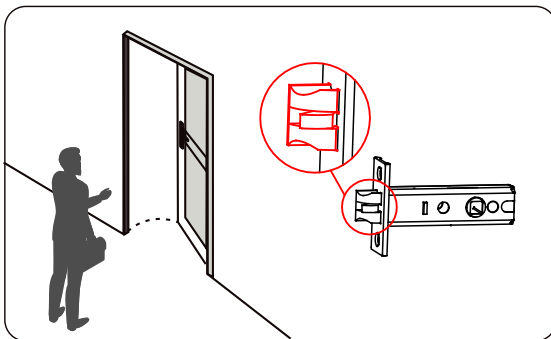

Slanted side Facing Door Frame when closing

Example 2

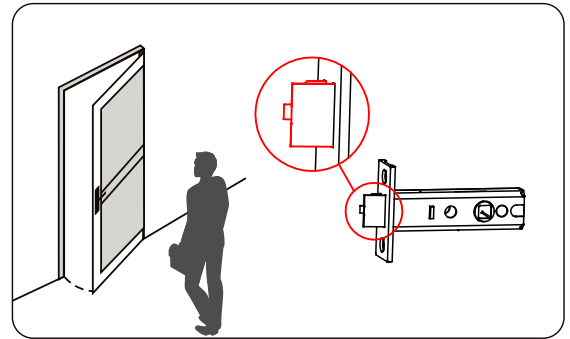

Slanted side Facing Door Frame when closing

OR

**2.3** Secure lockset with provided screws, labelled G (Step 2.1) as shown.

## STEP 3: CHANGING HANDLE ORIENTATION FOR RIGHT OR LEFT SWING DOORS

### How to determine if your door is a Right Swing or Left Swing door?

While facing the door, if the door hinges are on the right side of the door, you have a Right Swing Door. If the hinges are on the left side of the door, you have Left Swing Door.

The lock ships default for Right Swing Doors. You may skip STEP 3 if your door is a Right Swing Door. To change your door handle orientation for a left swing door, please continue reading.

### Changing the Exterior Handle Orientation

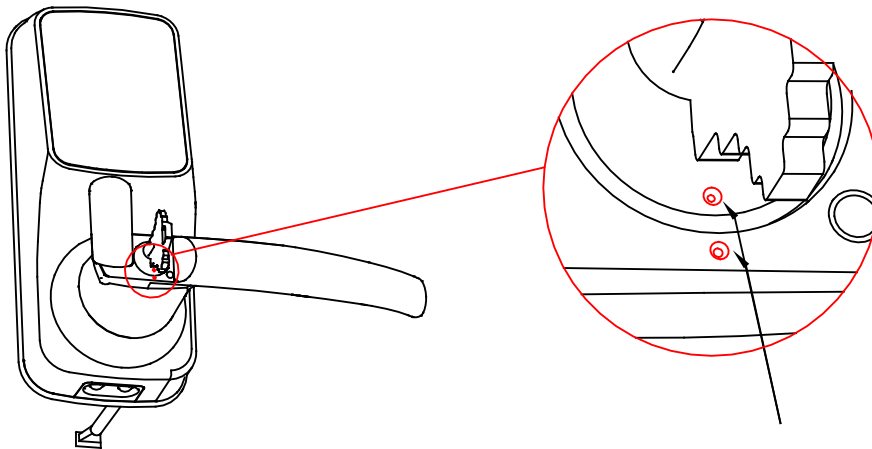

3.1

Insert the key and rotate to align the two white dots as shown in the picture.

#### **IMPORTANT:**

The following steps are only possible when these two white dots are aligned!



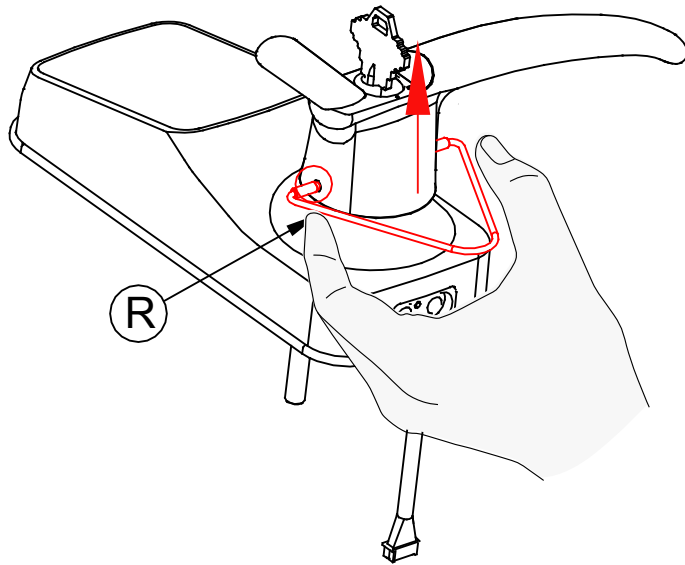

### 3.2

Use the provided Clamping tool (R) to push in the two metal pins at the base of the lock handle, located at the 3 o'clock and 9 o'clock positions, and remove the handle once the pins are compressed.

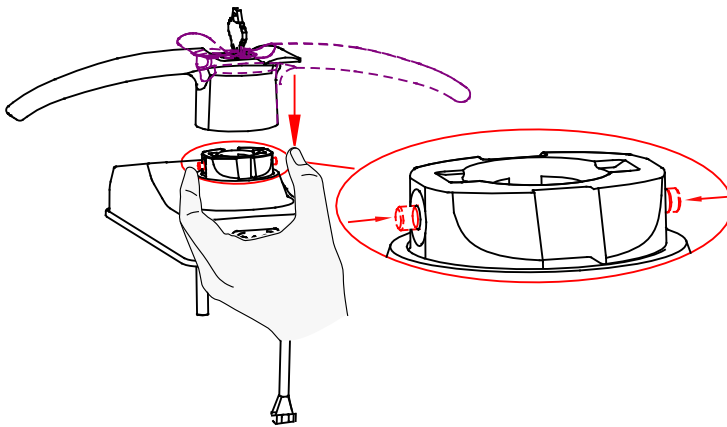

### 3.3

Rotate the handle 180 degrees to the other side of the lock.

Using your fingers, press the two pins located on the left and right side of the the lock to insert the handle back onto the lock.

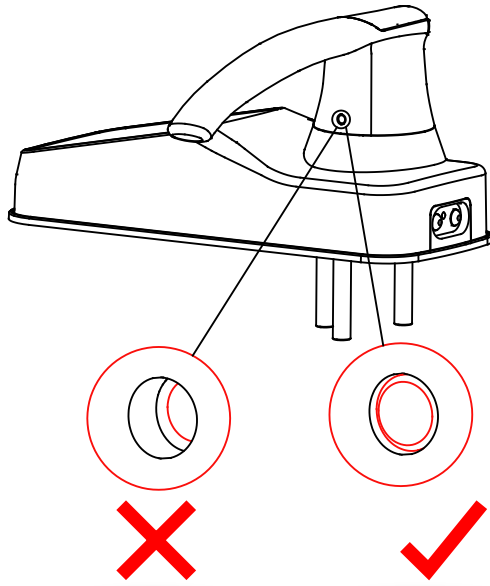

### 3.4

Confirm that your installation was complete by checking if the pins are flush against the handle, and has popped out. Adjust the handle accordingly to make sure the pins are fully decompressed and sits flush against the surface.

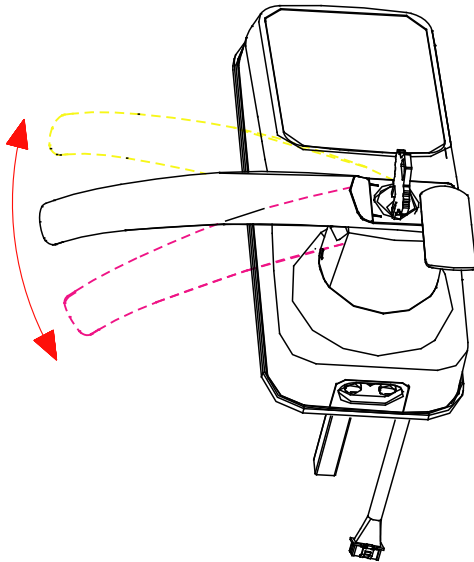

### 3.5

Check that your handle works smoothly by giving it a turn up and down. Your key can then be taken out once it goes back to the Horizontal position.

## Changing the Interior Handle Orientation

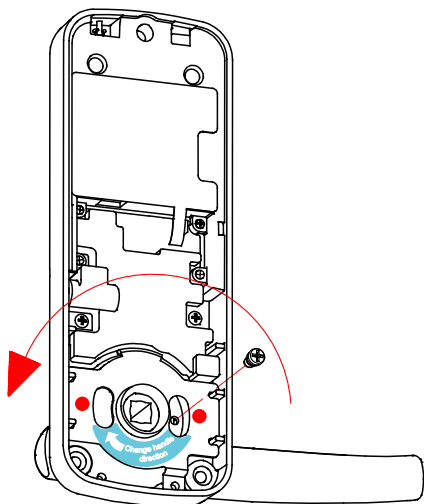

### 3.6

Remove the screw by turning counter clockwise and rotate the handle 180° in the direction of the arrow as shown. Make sure the screw hole is aligned with the marker as illustrated.

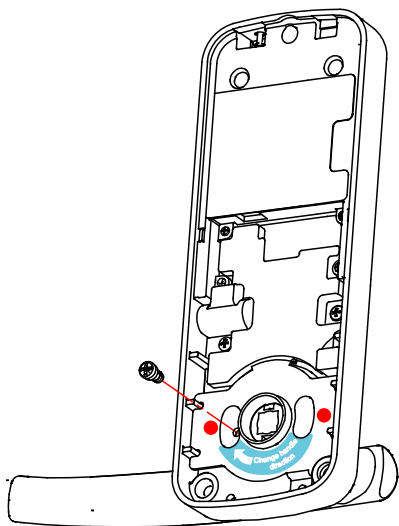

### 3.7

Securely screw clockwise as shown to complete your handle orientation change.

## STEP 4: PREPARING LOCK FOR INSTALLATION

If you drilled a hole in Step 1, use pole (**Part U**) and securely tighten with a flat head screwdriver by turning it clockwise onto the lock. If you did not drill a hole in step 1, you can leave this pole removed.

4.1

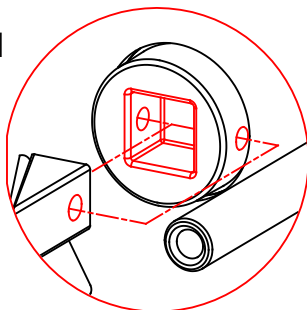

Install **Part C** with the holes side into the base of the lock and align the holes locate in the 3 o'clock and 9 o'clock position.

4.2

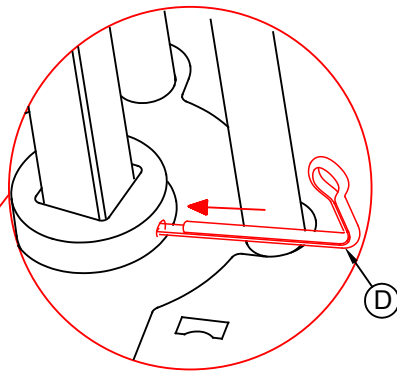

Insert locking pin **Part D** in to the hole as shown above.

4.3

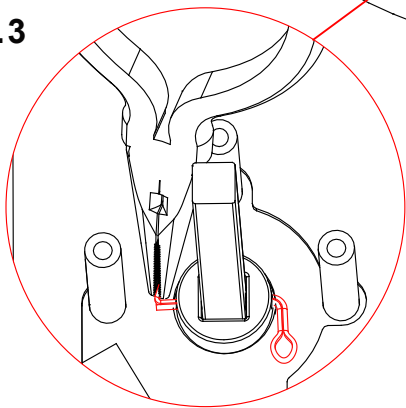

Lightly bend **Part D** so it's locked into place from moving as shown. We recommend using pliers.

4.4

Peel paper layer OFF the 3M tape and prepare for installation.

After you finished bending the locking pin, turn the handle to make sure it turns freely and nothing is obstructed.

## STEP 5: INSTALLING THE LOCK (EXTERIOR)

**5.2** Install the exterior lock as shown to the left by aligning the lock straight and passing the cable and attached rods through the lockset.

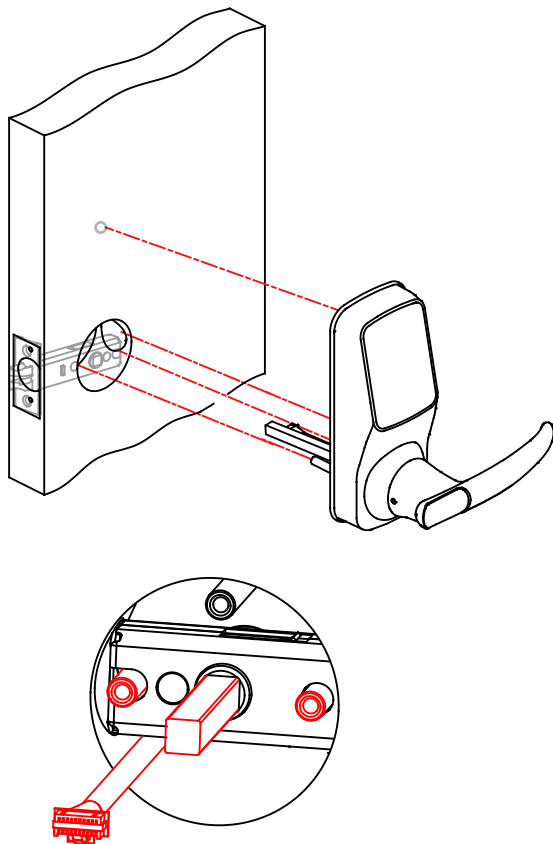

**5.3** Pass the square rod (Part C) through the center of the lockset, and the round rods through the sides in their respective holes. The cable should run underneath the lockset.

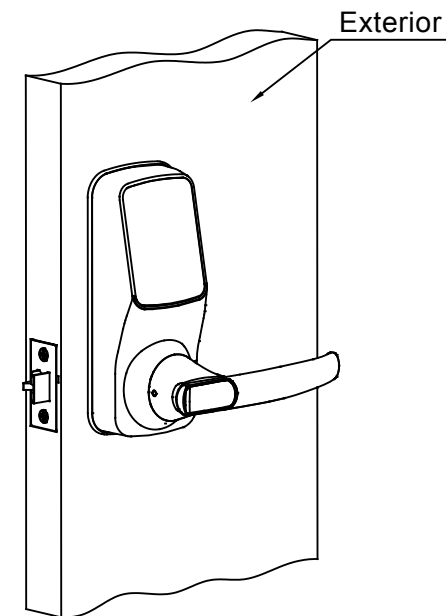

**5.4** Align the lock straight and press hard (if you use the 3M tape in step 4.4) to secure the top of the lock.

## STEP 6: INSTALLING THE LOCK (INTERIOR)

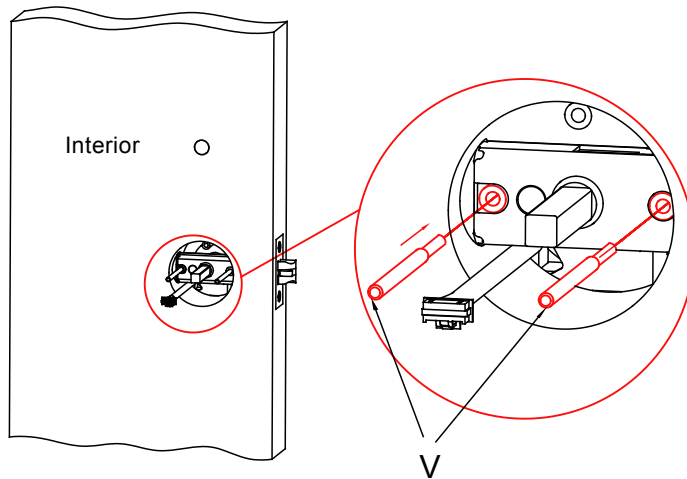

### 6.1

Insert positioning rods (Part V) into the the holes to the left and right of the square rod (Part C). The holes are located at the 3 o'clock and 9 o'clock positions.

### 6.2

Part LK (Interior Mounting Plate) will go against the interior side of your door. Remove the paper layer off of the 3M tape and **match the positioning rods on the bottom of the plate to the corresponding left and right holes.**

Install the side with the black plastic seal against the door.

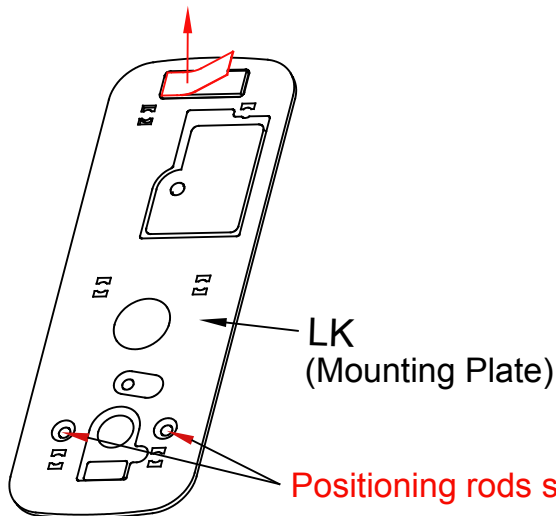

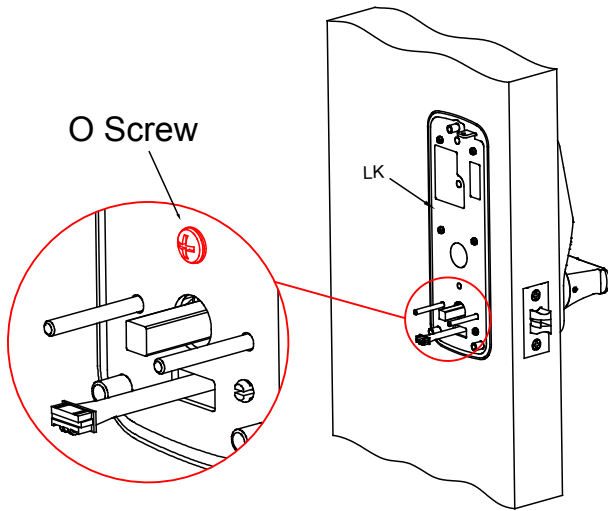

### 6.3

Pull the cable from the exterior lock through the rectangular hole underneath the positioning rods and square rod.

Secure the hole above the square rod with Part O screw.

### 6.4

Remove the position rods (Part V) and replace them with Part O screws. Tighten clockwise until the mounting plate is secure.

\* If you have drilled a hole on the top in Step 1, please secure the hole with part M1 or M2 depending on your door thickness. Skip this if no hole was drilled in Step 1.

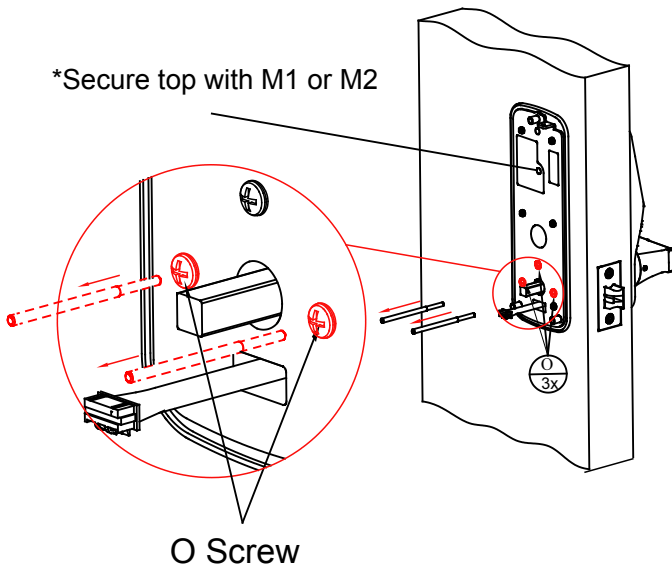

M1  PM5X25mm

M2  PM5X35mm

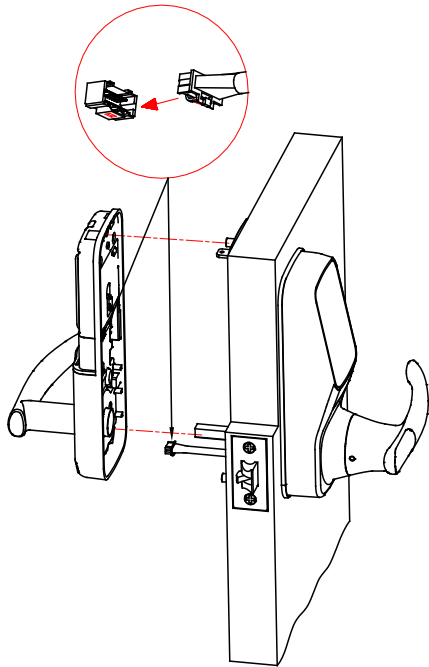

## 6.5

Plug the cable that is coming through the door into the Interior lock. Make sure you match the direction of the plug correctly and matching the red side of the plug with the red side on the lock.

## 6.6

Align the square rod to the Interior lock and attach the Interior lock to the Interior mounting plate.

While you are doing so, gently push some of the excess cable through the rectangular hole into the door.

Place the remaining cable against the interior side of the Interior lock so the Interior lock sits securely onto the mounting plate.

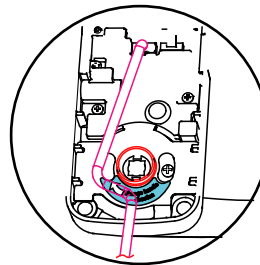
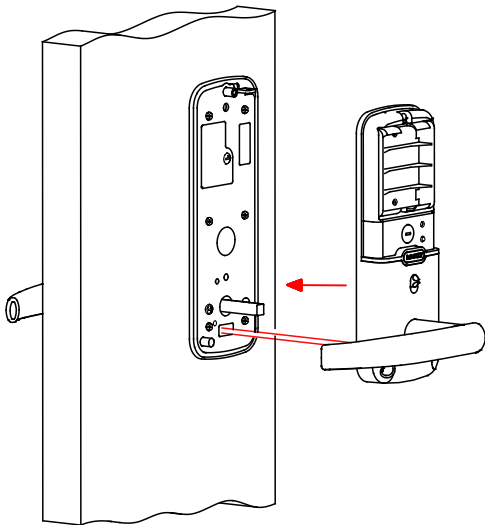



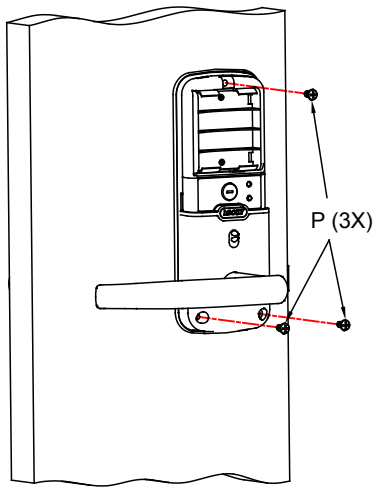

## 6.7

Once the Interior lock is flush against the mounting plate, secure the lock to the plate by screwing clockwise by using supplied screws (Part P).

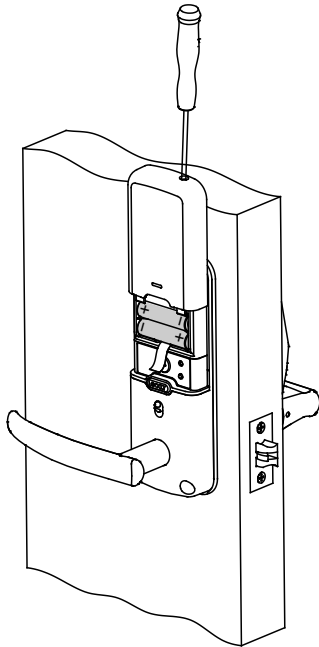

## 6.8

Insert 4 AA batteries into the lock by matching the positive (+) and negative (-) orientation markings on the batteries to the battery chamber.

Secure the battery cover by sliding the cover over the lock and turning the screw clockwise on top until tight.

## STEP 7: INSTALLING THE DOOR STRIKE

Close your door to see if your lock closes securely with your existing door strike. If the lock closes securely, you may keep the existing door strike without removing the old hardware. However, it's recommended that you use our door strike.

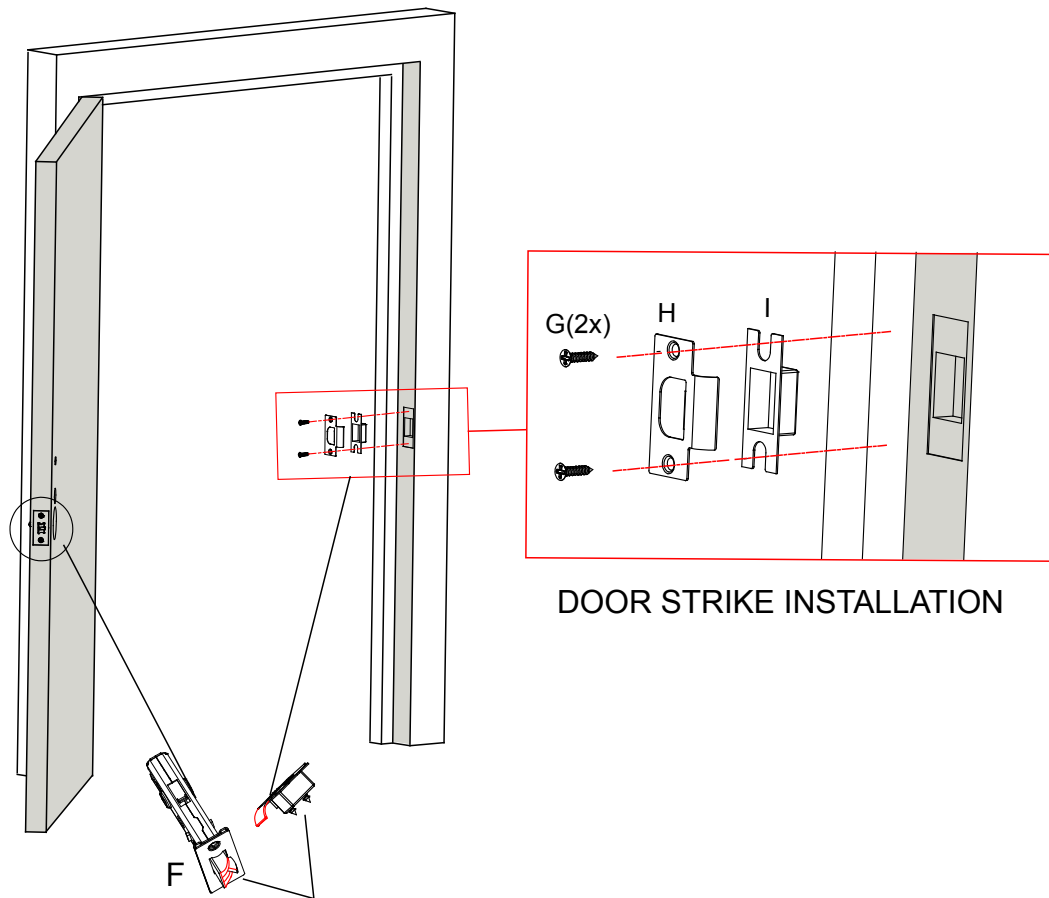

Make sure the slanted side of Part F1/F2 is closing against the slanted part of Part H before fixing it on to door frame.

## STEP 8: FINISHING INSTALLATION (DOOR LATCH)

You have completed the Lockly Secure physical lock installation. You can add Live Monitoring and Voice Assistant Control with Google Assistant or Amazon Alexa via installing the Secure Link Wi-Fi Hub and Door Sensor (included with Lockly Secure Pro and also sold separately). Please proceed to next page for Secure Link Installation.

For Secure and Secure Plus, download the Lockly™ app from the iOS or Google Play app Store. Follow on-screen instructions to complete your setup and installation.



**Scan or visit [Lockly.com/app](https://lockly.com/app)**

## STEP 9: INSTALLING THE SECURE LINK WI-FI HUB

The Lockly™ Secure Link Wi-Fi Hub comes in two parts. Each part of the Secure Link is crucial to enable voice assistant features and live monitoring and control of your Lockly™ device.

The Wireless Door Sensor is optional but highly recommended as they provide the ability to verify that your door is securely closed and not ajar.

### PART A



### PART B

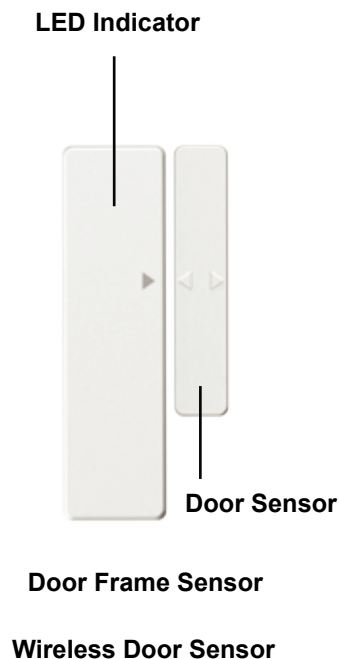

*\*You may plug the USB Secure Link Wi-Fi Hub into any UL Certified 5V 1A USB outlet, however we recommend using ours for best performance.*

## STEP 10: SETTING UP THE SECURE LINK WI-FI HUB

You should install the Secure Link Wi-Fi Hub after you have successfully finished installation and set up of your Lockly™ Smart Lock. Refer to your appropriate Lockly™ Smart Lock Installation Guide and User Manual that came with the lock for reference.

The Secure Link Wi-Fi Hub (Part A) can be plugged into any standard 5V 1A USB port or use the UL certified USB AC adapter included in this box (recommended).

For best connectivity, the Secure Link Wi-Fi Hub must be installed within 10 feet of your Lockly™ Smart Lock. You may experience delayed or intermittent connectivity if the Secure Link Wi-Fi Hub is installed further than 10 feet away from the Lockly™ Smart Lock.

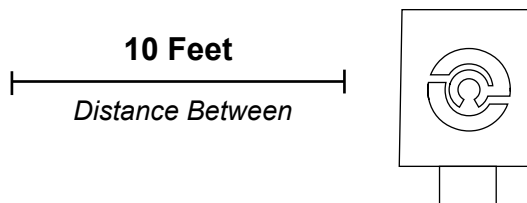

**Lockly™ Smart Lock**

**Secure Link Wi-Fi Hub**  
(Reference Image Only)

The Secure Link requires a strong wireless signal for optimal performance. Make sure the Secure Link will be installed in a location with a strong 2.4 Ghz wireless signal.

Plug the Secure Link Wi-Fi Hub into the 5V 1A USB AC adapter and plug the AC adapter to your wall socket.



**USA Outlet Shown**

A red LED indicator light will flash slowly to indicate that the Wi-Fi Hub is ready to connect.



**LED Indicator is located next to the Setup Button**

Once you have confirmed that your Secure Link Wi-Fi Hub is ready to connect to your lock, open the Lockly™ app to get started.



In case you have not downloaded our app, you can scan the QR code to the left or visit <https://lockly.com/app>



Make sure you have already created an account and setup your Lockly device to the Lockly app to continue.

Before you continue the Secure Link Wi-Fi Hub set up on your app, proceed to the next page to learn more about using the Secure Link Wi-Fi Hub and best practices for connectivity.

## STEP 11: USING THE SECURE LINK WI-FI HUB

Before you set up your Wi-Fi Hub, make sure you are standing in between your Lockly Smart Lock and Secure Link Wi-Fi Hub. For best connection, the distance between the Wi-Fi Hub and your smart lock should be 10 feet or less.

### Lockly™ Smart Lock

*Shown  
as reference only*

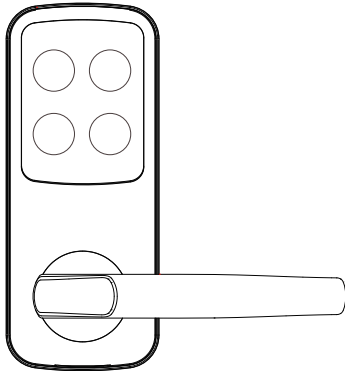

### You

*Using an iOS or Android  
Device with Bluetooth & Wi-Fi enabled*

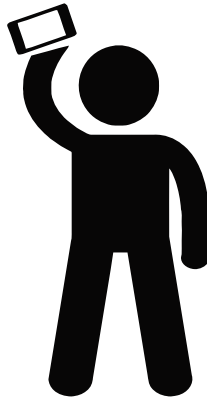

### Secure Link Wi-Fi Hub

*Part A Shown Above  
as reference only*

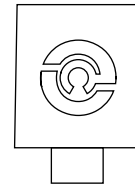

**10 Feet**

*Distance Between*



In order for your Secure Link Wi-Fi Hub to connect to the internet, you must have a Wi-Fi network with a radio signal emitting 2.4 GHz. All modern Wi-Fi devices support 2.4 GHz connections while some equipment supports both 2.4 GHz and 5 GHz. Please check with your network administrator or internet provider if you're unsure what kind of network you have.

Proceed to the next page to read how to finish set up of your Wi-Fi Hub.

# Secure Link Installation Checklist.



I'm excited for my new Lockly smart lock, now compatible with Alexa and Google Assistant.\*



You have a Lockly Smart Lock already, and now adding the Wi-Fi Hub



The Secure Link Wi-Fi Hub is installed within 10 feet of your Lockly Smart Lock



You have the Lockly App installed on your iOS or Android device.



Your smartphone Bluetooth connection is ON and connected to your Lockly device.



You are standing between your smart lock and the Secure Link Wi-Fi Hub.



Your Secure Link Wi-Fi Hub is located in a location with a strong Wi-Fi signal.



You are currently connected to a 2.4 GHz Wi-Fi Network (802.11 B/G/N) on your iOS or Android device.

Be sure you check off the above 6 boxes before proceeding. If any of the boxes are not checked, you may experience intermittent or delayed response time in notifications.

*\*Requires successful installation of the Secure Link Wi-Fi Hub and connected to a strong internet connection*



## STEP 12: CONFIGURING THE SECURE LINK WI-FI HUB

First, make sure the smartphone you are using to add the Wi-Fi Hub is connected to your 2.4 GHz Wi-Fi Network. Next, open your Lockly App and select the main menu from the upper left corner. (Image shown with iOS demo). Once the menu opens go ahead select “Set up a New Device”

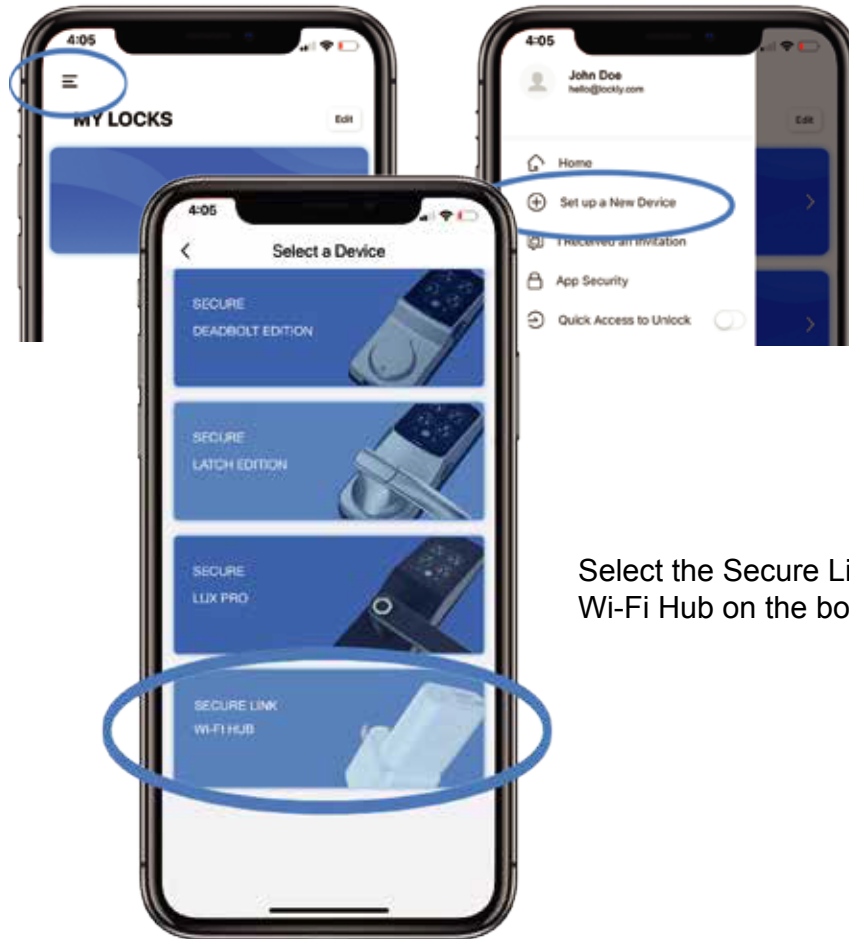

Select the Secure Link  
Wi-Fi Hub on the bottom

**NEXT >**

If you have never connected the Secure Link Wi-Fi Hub to your smart lock, the Secure Link should have a slow flashing **RED** LED Indicator. Press and hold the Setup Button located on the top of the Wi-Fi Hub for 3 seconds until you see the **RED** LED Indicator start to rapidly flash.



If you don't see anything appear with a Bluetooth icon and a name starting with PGH200... simply click the Refresh button on the upper right to rescan. Make sure your Wi-Fi Hub is showing a flashing **RED** LED indicator and the Wi-Fi Hub is within the optimal distance of 10 feet from your lock. Select the desired Wi-Fi Hub to continue.

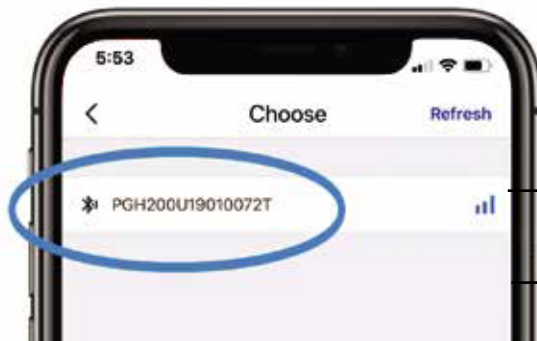

**Refresh**

**Minimum 2-3 Bars  
Recommended**

If you are already connected to a 2.4 Ghz compatible Wi-Fi network, it should display the network name. (See example below)

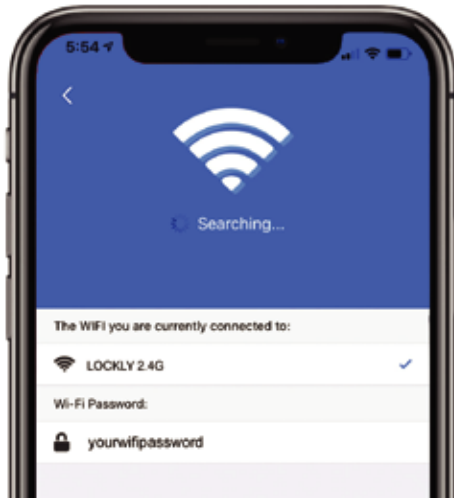

Enter your Wi-Fi password in the next line next to the  icon, then click “Next Step” to continue.

Select if your Wi-Fi Hub LED Indicator light is ON and solid.

Select if your Wi-Fi Hub LED Indicator light is ON and still flashing after 2-3 minutes.

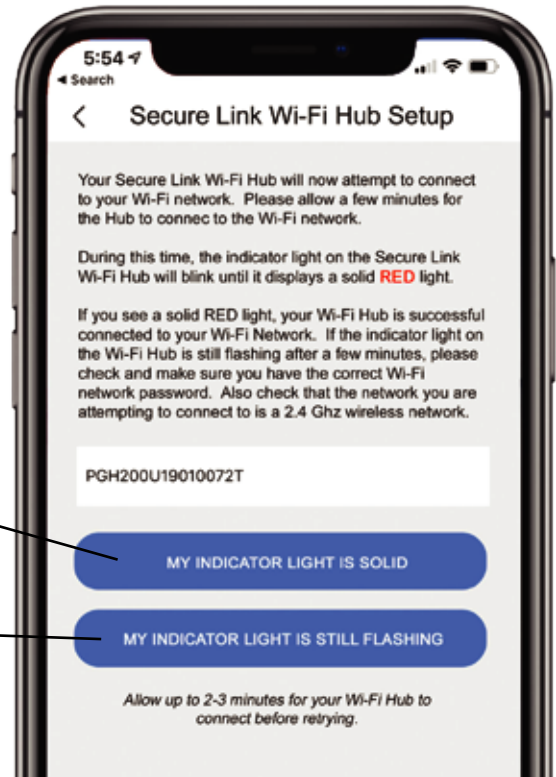

*\*Actual screen may differ depending on device and app version  
Please follow on -screen instructions.*

# Congratulations! Your Secure Link Wi-Fi Hub is now set up.

Below are some quick information for troubleshooting.



## No Indicator Light

Your Wi-Fi Hub has no power.  
Check your the power supply.



## Rapid Flashing Indicator Light

Your Wi-Fi Hub is in setup mode.  
Setup mode can be entered by pressing  
the setup button for 2 seconds.

*Setup mode will last approx 2 minutes.*



## Slow Flashing Indicator Light

Your Wi-Fi Hub has power.  
It's not connected to any  
wireless network.



## Solid Indicator Light

Your Wi-Fi Hub is on and connected to  
an active 2.4 Ghz wireless network.

**CONTINUE TO NEXT PAGE TO INSTALL DOOR SENSOR >**

## STEP 13: ADDING THE DOOR SENSOR

Adding the door sensor (Part B) is optional, however we strongly recommend installing the Door Sensor as it provides the ability to verify that your door is securely closed and not ajar and also send push notifications to your phone on the status of your door when someone opens and closes the door.

Depending on your door orientation, your Door Sensor will be mounted different ways. The Door Sensor comes in two parts.

**Part 1 - Door Frame Sensor**



**Part 2 - Door Sensor**

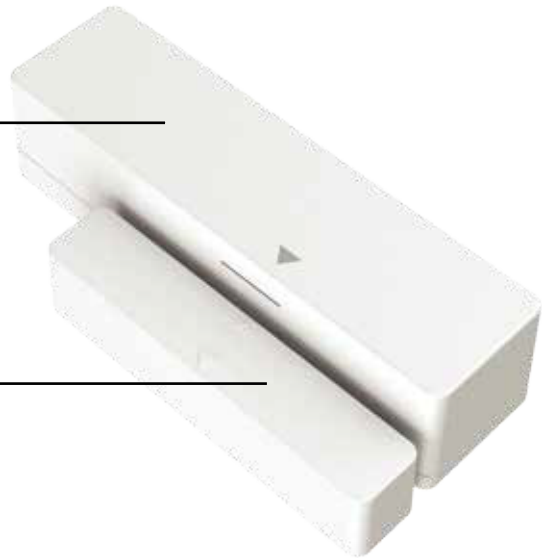

Make sure you install the Door Sensor indoors on a clean and dry surface. Gently wipe the surface of your door and door frame where you wish to install the Door Sensor and make sure it's dry before installing.

**NEXT >**

Keep the Door Sensor away from direct sunlight, high heat locations and large metal objects that may interfere with wireless signals.

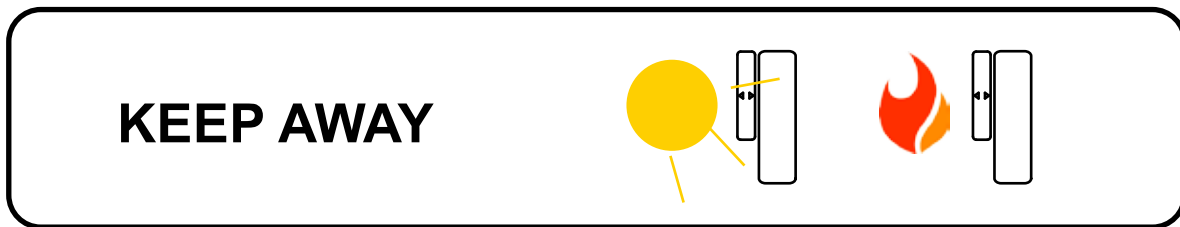

The optimal location to install the Door Sensor is on the upper corners of your door, away from the reach of children and pets.

**WHEN FACING YOUR DOOR  
FROM THE INSIDE, DOOR HINGES  
ARE ON THE RIGHT SIDE**



**WHEN FACING YOUR DOOR  
FROM THE INSIDE, DOOR HINGES  
ARE ON THE LEFT SIDE**



**DON'T INSTALL SENSOR YET. NEXT >**

When you are installing the Door Sensor, make sure the arrows on the Door Sensor is placed next to the arrow from the Door Frame Sensor.

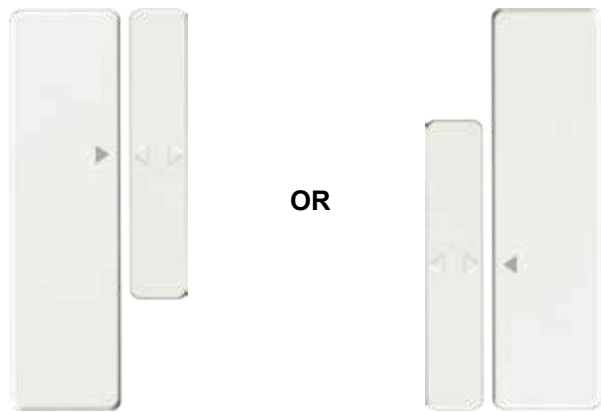

When installed on your door, the distance between the Door Sensor and the Door Frame Sensor must be less than 3/4" in order for the sensor to work.



**Gap - less than 3/4" when installed.**

When you are ready to install, pull the plastic tab at the back of the Door Frame Sensor to activate the sensor.

Peel back the protective paper on the double sided tape to expose the adhesive and apply securely to your door and door frame.

Follow the On-Screen instructions on the app to test your Door Sensor.

# Congratulations! The Door Sensor is now set up.

The Secure Link Wi-Fi Hub works with other Smart Home devices. Check on the status or remote lock and unlock your door by your voice using Amazon Alexa or Google Home Assistant.



To setup your lock to work with either of those platforms, download the Amazon Alexa or Google Home Assistant app and add a new skill with Amazon Alexa or an Action with Google Home Assistant.

**Add the “Lockly” Skill (Alexa) and Action (Google)  
then follow on screen instructions to finish set up.**

**For a full list of commands, help videos or to troubleshoot your  
Secure Link Wi-Fi Hub visit us at <https://lockly.com/help>**



**LOCKLY™ SECURE**



**We're here to help!**  
**help@lockly.com**  
**<https://lockly.com/help>**