

# INSTALLATION INSTRUCTIONS FOR SINGLE WALL MOUNTED STORAGE SHELF

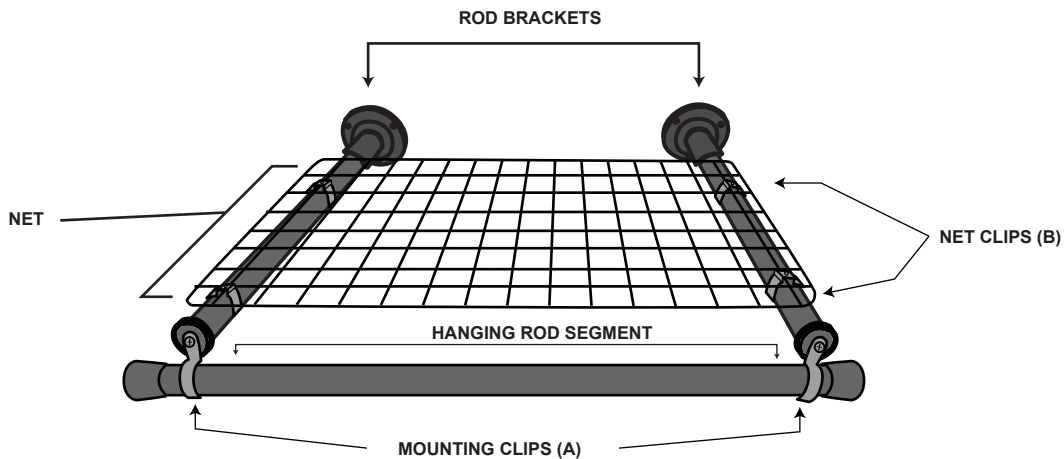

- 1** Lightly mark points on the wall where shelf will be mounted.

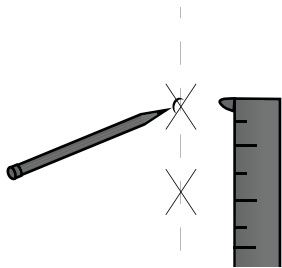

- 2** Retrieve the mounting template from the package of components along with 3 double sided adhesive pieces of tape. Peel off one side of the tapes' covers and stick them on the backside of the mounting template.

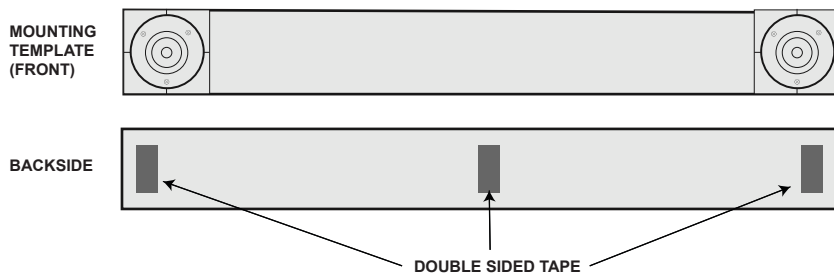

- 3** Use a level when sticking the template to the wall. Mark the wall through the template to spot the drill holes for the two rod brackets.

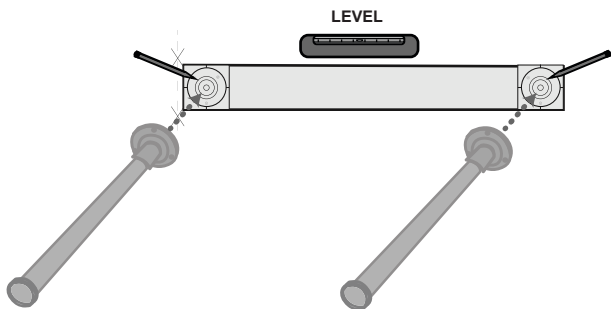

- 4** Remove the template and drill holes at the marked locations. Firmly seat drywall anchors using a mallet and use screws to mount the brackets.

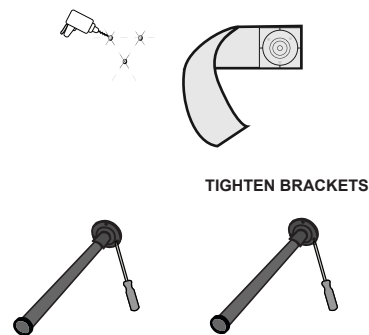

- 5** Proceed to attach mounting clips to ends of the hanging rod segments and attach them to the outer rod brackets with screws.

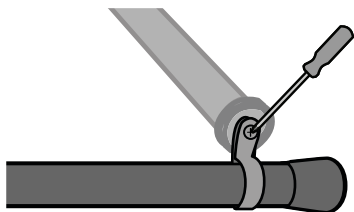

- 6** Place net on the rod brackets. Fasten the metal net to the brackets by placing net clips (B) onto 4 points (see example below). Once you have done so, the shelf is completed.

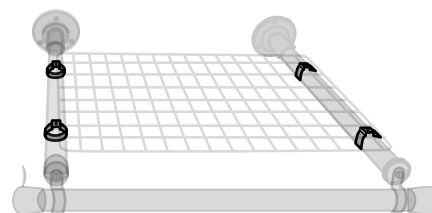

## DRYWALL ANCHOR INSTALLATION



If screws are going directly into wood trim or wall studs - drill 1/8" (3mm) holes and install screws through bracket. If screws are going into hollow wall - drill 3/16" (5mm) holes and push or lightly hammer plastic anchors into holes. Then install screws through brackets. Do not tighten screws too much - just snug is best.

## METAL WALL ANCHOR INSTALLATION\*



\*USE ON 3/8"-1/2" THICK WALLS  
ONLY!

1 Drill a hole into the wall, using a 1/4"(6mm) inch drillbit.



3 Attach drill or screwdriver to head of screw and expand the anchor by tightening the head.

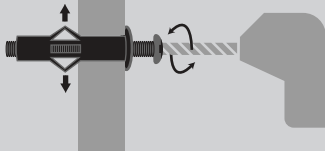

2 Tap the anchor into the hole until it is flush with the surface of the substrate.

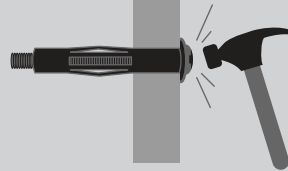

4 Remove the screw and place it through the fixture then back into the anchor. Tighten the screw until the fixture is secure.

