



Item #1002 582 973/1002 631 990

Model #D9127-7PC/D9127-7PCR

## USE AND CARE GUIDE

---

### WOODBURY DINING CHAIR

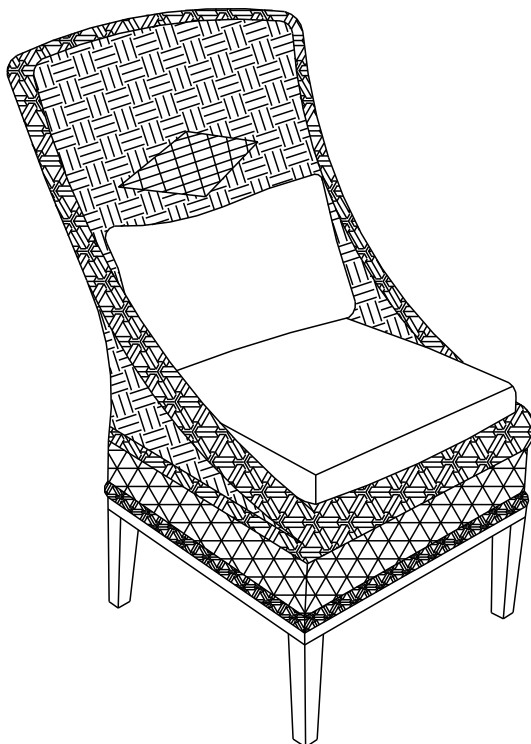

Questions, problems, missing parts? Before returning to the store,  
call Hampton Bay Customer Service  
8 a.m. - 7 p.m., EST, Monday-Friday  
9 a.m. - 6 p.m., EST, Saturday

**1-855-HD-HAMPTON**

**HAMPTONBAY.COM**

---

#### **THANK YOU**

*We appreciate the trust and confidence you have placed in Hampton Bay through the purchase of this dining chair. We strive to continually create quality products designed to enhance your home. Visit us online to see our full line of products available for your home improvement needs. Thank you for choosing Hampton Bay!*

# Table of Contents

Table of Contents.....	2	Assembly .....	5
Warranty.....	2	Care and Cleaning .....	6
What is Covered .....	2		
What is Not Covered .....	2		
Pre-Assembly .....	3		
Planning Assembly .....	3		
Hardware Included.....	3		
Dining Chair Package Contents.....	4		

# Warranty

**THIS IS A RESIDENTIAL WARRANTY ONLY AND THIS WARRANTY DOES NOT APPLY TO COMMERCIAL USE**

**5 YEAR FRAME LIMITED WARRANTY/2 YEAR RESIN WEAVE AND FABRIC LIMITED WARRANTY**

## WHAT IS COVERED

We warrant the frame to be free of manufacturing defects to the original purchaser for five years and the resin weave and fabric for two years.

## WHAT IS NOT COVERED

It remains the customer's responsibility for freight and packaging charges to and from our service center.

This warranty does not cover commercial use, hardware, acts of nature, fire, freezing, and abusive use.

In addition, purchased parts are not covered under this warranty. We reserve the right to make substitutions with similar merchandise, if the model in question is no longer in production.

For a copy of our full limited warranty, please contact our customer service team below.

Contact the Customer Service Team at 1-855-HD-HAMPTON or visit [www.hamptonbay.com](http://www.hamptonbay.com).

# Pre-Assembly

## PLANNING ASSEMBLY

Please read this entire instruction manual prior to assembly.

Identify all parts packed in the carton against the parts list. Remove all protective materials and place the parts on a non-abrasive surface to avoid scratching.



**NOTE:** More than one person may be required to complete the assembly of this product.

## HARDWARE INCLUDED



**NOTE:** Tools not shown to actual size.



Part	Description	Quantity
AA	M6*40 Hex bolt	6
BB	Washer	6
CC	Cap	6
DD	M6 Wrench	1

## Pre-Assembly (continued)

### DINING CHAIR PACKAGE CONTENTS

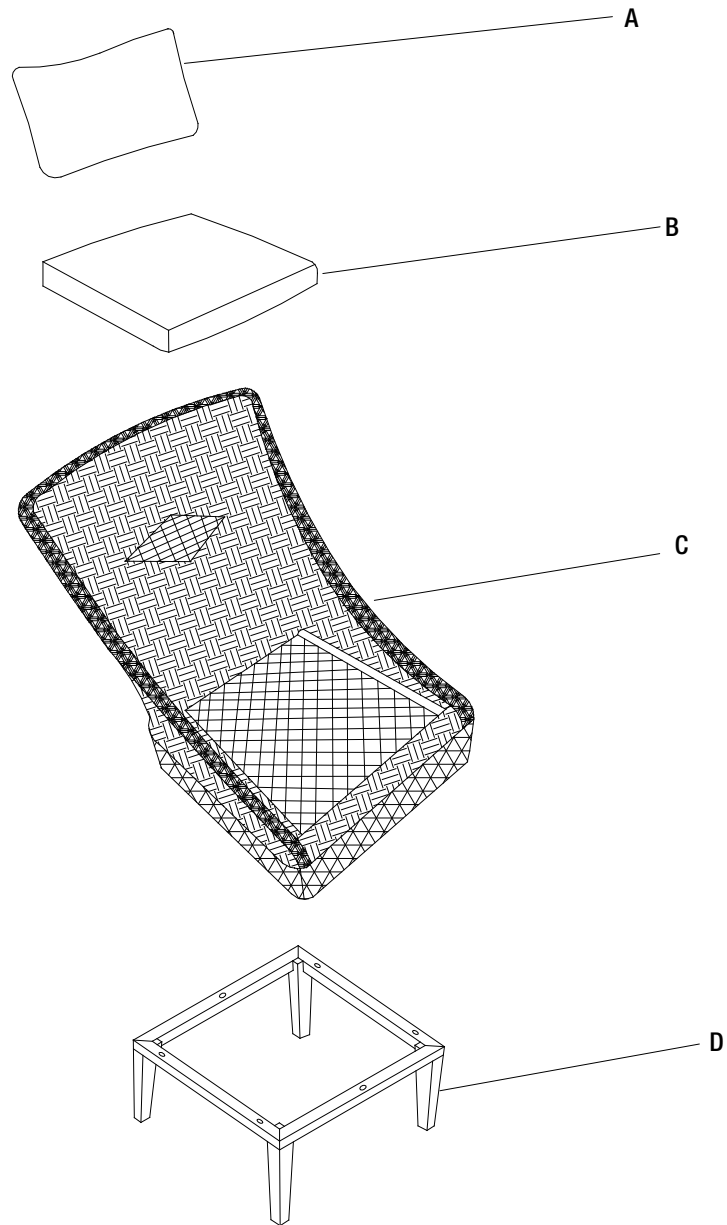

Part	Description	Quantity
A	Lumbar pillow	1
B	Seat cushion	1
C	Chair frame	1
D	Chair base	1

# Assembly

## 1 Attaching the chair base

- Attach the chair base (D) to the chair frame (C) using the M6 washers (BB) and M6 hex bolts (AA).
- Tighten all M6 hex bolts (AA) with the M6 wrench (DD).
- Tighten all bolts and cover the heads with caps (CC).



**NOTE:** Please ensure all M6 hex bolts (AA) are aligned and assembled correctly. Fully tighten the bolts.

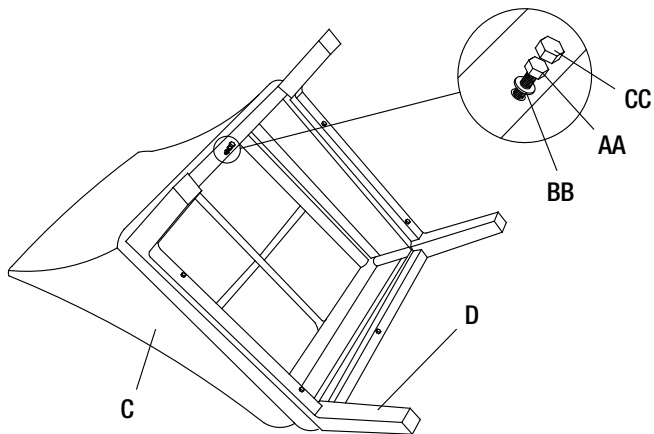

## 2 Attaching the seat cushion and lumbar pillow

- Place the seat cushion (B) and lumbar pillow (A) onto the chair.

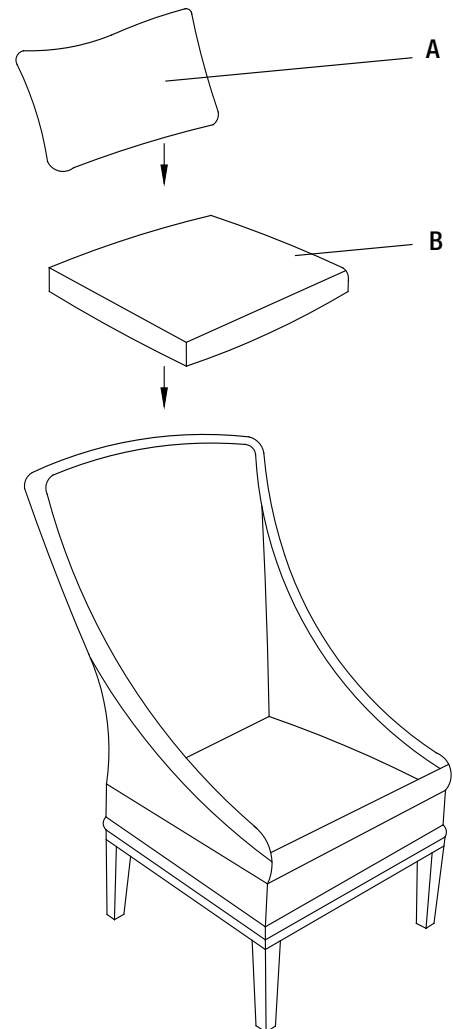

## Care and Cleaning

---

- Do not allow water to build up in the frames. This will cause corrosion and possible freezing damage in cold climates.
- Use a mild soap and water for normal cleaning. Do not use janitorial or alcohol based cleaners. Some cleaners may be marked as natural, but some ingredients may cause discoloration or have an adverse reaction to your finish.
- Rinse with clean water and dry with a soft, absorbent cloth towel.
- Treat frames with a liquid wax for maximum protection against UV rays and/or salty, damp air.



Questions, problems, missing parts? Before returning to the store,  
call Hampton Bay Customer Service  
8 a.m. - 7 p.m., EST, Monday-Friday  
9 a.m. - 6 p.m., EST, Saturday

**1-855-HD-HAMPTON**

**HAMPTONBAY.COM**

Retain this manual for future use.



Item #1002 582 972/1002 631 991  
Model #D9127-7PC/D9127-7PCR

# USE AND CARE GUIDE

---

## WOODBURY DINING TABLE

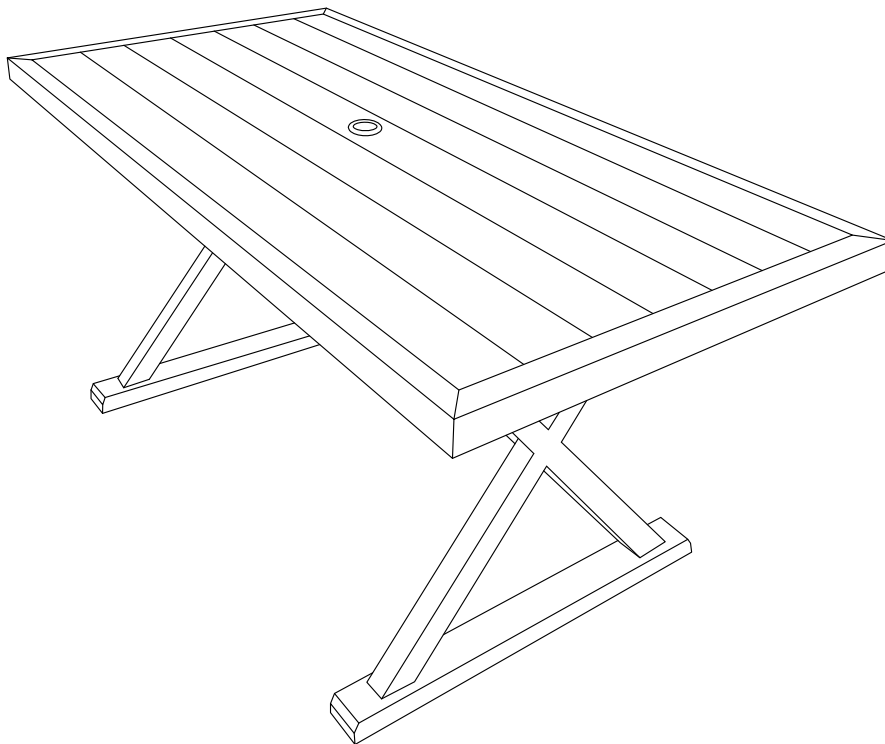

Questions, problems, missing parts? Before returning to the store,  
call Hampton Bay Customer Service  
8 a.m. - 7 p.m., EST, Monday-Friday  
9 a.m. - 6 p.m., EST, Saturday

**1-855-HD-HAMPTON**

**HAMPTONBAY.COM**

---

### **THANK YOU**

*We appreciate the trust and confidence you have placed in Hampton Bay through the purchase of this dining table. We strive to continually create quality products designed to enhance your home. Visit us online to see our full line of products available for your home improvement needs. Thank you for choosing Hampton Bay!*



## Table of Contents

Table of Contents.....	2	Pre-Assembly.....	3
Safety Information.....	2	Planning Assembly.....	3
Warranty.....	2	Hardware Included.....	3
What is Covered.....	2	Table Package Contents .....	4
What is Not Covered .....	2	Assembly .....	5
		Care and Cleaning.....	6

## Safety Information



**WARNING:** Do not place heavy items on the table top.



**WARNING:** An umbrella base must be used at all times when an umbrella is in use. Do not use an umbrella in the event of wind, rain, hail, sleet, snow, or any other inclement weather.



**WARNING:** Do not sit or stand on the table top.

## Warranty

**THIS IS A RESIDENTIAL WARRANTY ONLY AND THIS WARRANTY DOES NOT APPLY TO COMMERCIAL USE**

### **5 YEAR FRAME LIMITED WARRANTY**

#### **WHAT IS COVERED**

We warrant the frame to be free of manufacturing defects to the original purchaser for five years.

#### **WHAT IS NOT COVERED**

It remains the customer's responsibility for freight and packaging charges to and from our service center. This warranty does not cover commercial use, hardware, acts of nature, fire, freezing, and abusive use. In addition, purchased parts are not covered under this warranty. We reserve the right to make substitutions with similar merchandise, if the model in question is no longer in production.

For a copy of our full limited warranty, please contact our customer service team below.

Contact the Customer Service Team at 1-855-HD-HAMPTON or visit [www.hamptonbay.com](http://www.hamptonbay.com).

# Pre-Assembly

## PLANNING ASSEMBLY

Please read this entire instruction manual prior to assembly.

Identify all parts packed in the carton against the parts list. Remove all protective materials and place the parts on a non-abrasive surface to avoid scratching.



**NOTE:** More than one person may be required to complete the assembly of this product.

## HARDWARE INCLUDED



**NOTE:** Tools not shown to actual size.

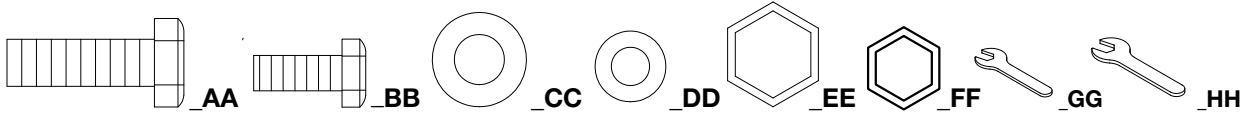

Part	Description	Quantity
AA	M8*25 Hex bolt	16
BB	M6*15 Hex bolt	2
CC	M8 Hex bolt washer	16
DD	M6 Hex bolt washer	2
EE	M8 Hex bolt cap	16
FF	M6 Hex bolt cap	2
GG	M6 Wrench	1
HH	M8 Wrench	1

# Pre-Assembly

## TABLE PACKAGE CONTENTS

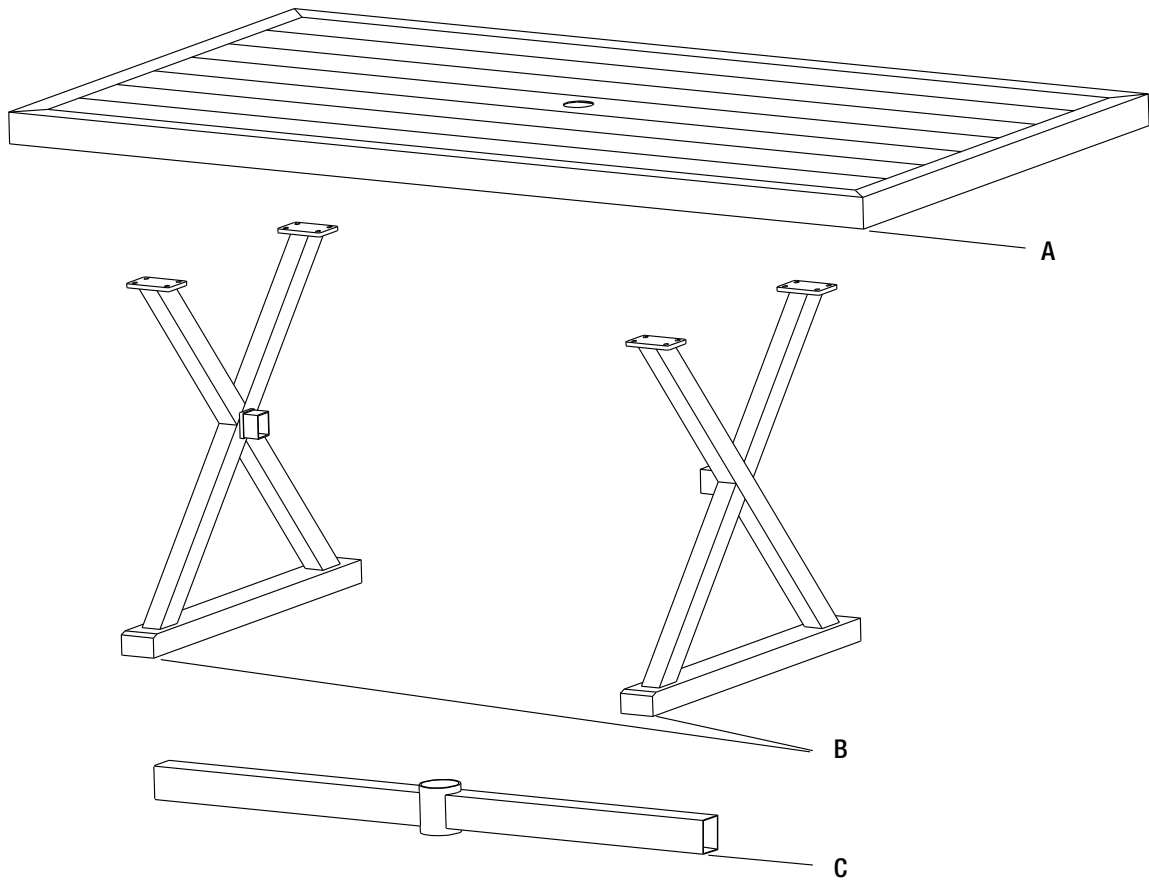

Part	Description	Quantity
A	Table top	1
B	Table leg	2
C	Connector	1

# Assembly

## 1 Attaching the table legs

- Attach the connector (C) to the table legs (B) using the M6 hex bolts (BB) and washers (DD). Tighten all bolts and cover the bolt heads with caps (FF).



**NOTE:** Please ensure the bolts are assembled correctly and use the M6 wrench (GG) to tighten.

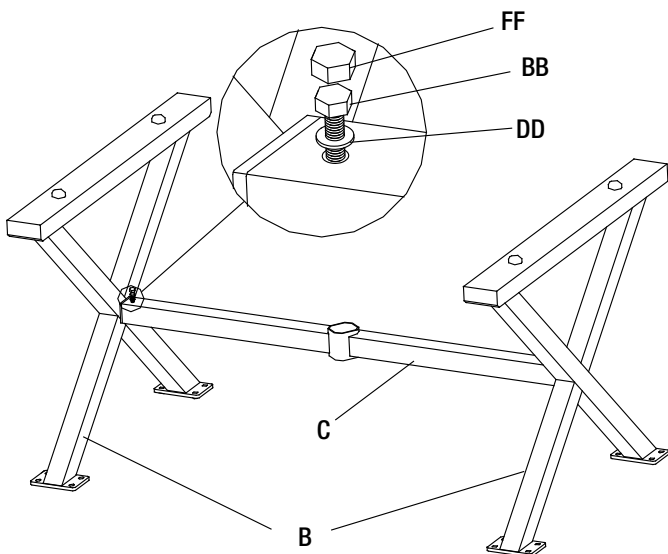

## 2 Attaching the table top

- Place the table top (A) on a soft, flat non-abrasive surface. Attach the table legs (B) to the table top (A) with the M8 hex bolts (AA) and washers (CC). Tighten all bolts and cover the bolt heads with caps (EE).



**NOTE:** Please ensure all the bolts are assembled correctly and use the M8 wrench (HH) to tighten.

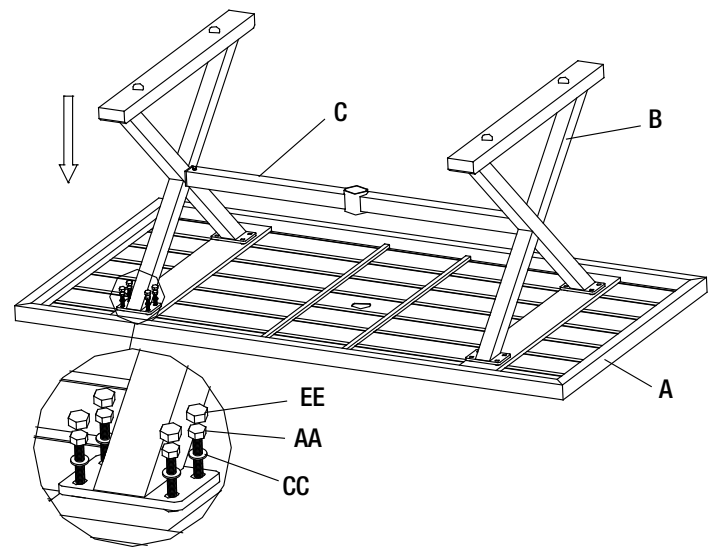

## 3 Positioning the table

- With the assistance of another person turn the table over and set it down on its legs.
- The table is now ready for use.

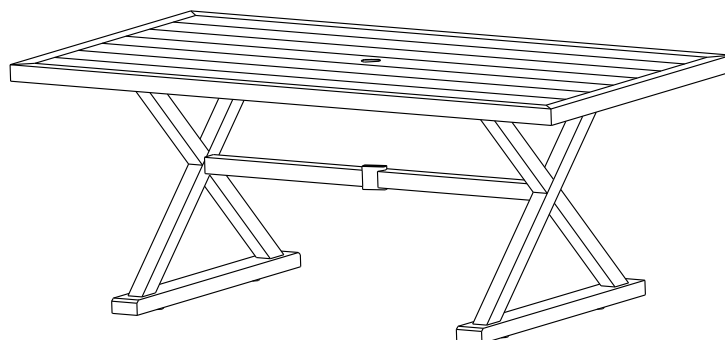

## Care and Cleaning

---

- Do not allow water to build up in the frames. This will cause corrosion and possible freezing damage in cold climates.
- Use a mild soap and water for normal cleaning. Do not use janitorial or alcohol based cleaners. Some cleaners may be marked as natural, but some ingredients may cause discoloration or have an adverse reaction to your finish.
- Rinse with clean water and dry with a soft, absorbent cloth towel.
- Treat frames with a liquid wax for maximum protection against UV rays and/or salty, damp air.



Questions, problems, missing parts? Before returning to the store,  
call Hampton Bay Customer Service  
8 a.m. - 7 p.m., EST, Monday-Friday  
9 a.m. - 6 p.m., EST, Saturday

**1-855-HD-HAMPTON**

**HAMPTONBAY.COM**

Retain this manual for future use.