



Masterbuilt Manufacturing, Inc.
 1 Masterbuilt Ct.
 Columbus, GA 31907
 Customer Service 1-800-489-1581
 www.masterbuilt.com





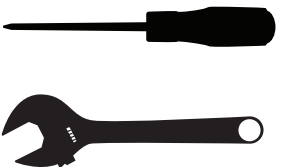
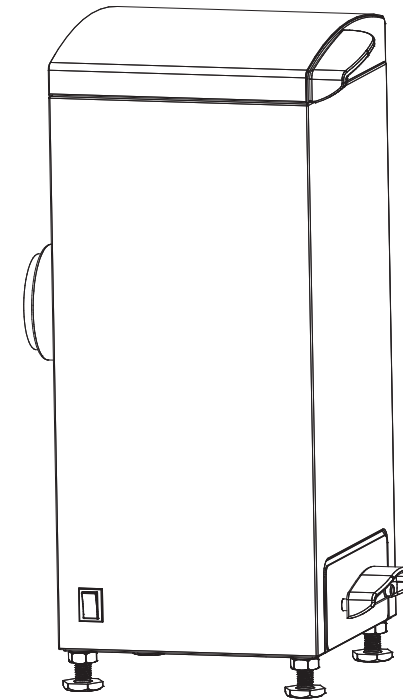

ASSEMBLY, CARE & USE MANUAL
WARNING & SAFETY INFORMATION
 COLD SMOKER MODEL 20070112
 THIS PRODUCT IS FOR OUTDOOR USE ONLY

Manual Code: 9807100051 011212-04JH



Approximate assembly time : 10 minutes

Tools required for assembly: Phillips Head screwdriver, Wrench

 CARBON MONOXIDE HAZARD 	 WARNING 
<p>Burning wood chips gives off carbon monoxide, which has no odor and can cause death.</p> <p>DO NOT burn wood chips inside homes, vehicles, tents, garages or any enclosed areas.</p> <p>Use only outdoors where it is well ventilated.</p>	<p>This manual contains important information necessary for the proper and safe use of this unit.</p> <p>Read and follow all warnings and instructions before using smoker and during use.</p> <p>Keep this manual for future reference.</p> <p>Some parts may have sharp edges; handle with care.</p>
<p>Failure to follow these warnings and instructions properly could result in personal injury or death.</p>	



GENERAL WARNINGS AND SAFETY INFORMATION



READ ALL INSTRUCTIONS

When using electrical appliances, basic safety precautions should always be followed including the following:

- For outdoor use only. Do not operate in an enclosed area.
- Unit **MUST** be on the ground. Do not place unit on tables or counters. Do **NOT** move unit across uneven surfaces.
- Do not lift unit by lid handle.
- Do not plug in cold smoker until fully assembled and ready for use.
- Use only approved grounded electrical outlet.
- Do not use during an electrical storm.
- Do not expose cold smoker to rain or water at anytime.
- To protect against electrical shock do not immerse cord or plug in water or other liquid.
- Do not operate any appliance with a damaged cord or plug, or after appliance malfunctions or has been damaged in any manner. Contact Masterbuilt Customer Service for assistance at 1-800-489-1581.
- Keep a fire extinguisher accessible at all times while operating cold smoker.
- Do not let cord touch hot surfaces if hanging.
- Do not place on or near a hot gas or electric burner, or in a heated oven.
- Keep children and pets away from electric smoker at all times. Do not allow children to use cold smoker. Close supervision is necessary should children or pets be in area where cold smoker is being used.
- Fuel, such as charcoal briquettes or heat pellets, are not to be used in cold smoker.
- Never use cold smoker as a heater (READ CARBON MONOXIDE HAZARD).
- Use cold smoker only on a level, stable surface to prevent tipping.
- Cold smoker is HOT during operation and remains HOT for a period of time following use.
- Do not touch HOT surfaces.
- Do not allow anyone to conduct activities around cold smoker during or following its use until the unit has cooled.
- The use of alcohol, prescription or non-prescription drugs may impair the user's ability to properly assemble or safely operate cold smoker.

WARNINGS & IMPORTANT SAFEGUARDS CONTINUED ON PAGE 2

LIMITED WARRANTY

Masterbuilt warrants its products to be free from defects in material and workmanship under proper assembly, normal use and recommended care for 90 days from the date of original retail purchase. Masterbuilt warranty does not cover paint finish as it may burn off during normal use.

Masterbuilt warranty does not cover rust of the unit.

Masterbuilt requires reasonable proof of purchase for warranty claims and suggests that you keep your receipt. Upon the expiration of such warranty, all such liability shall terminate.

Within the stated warranty period, Masterbuilt, at its discretion, shall repair or replace defective components free of charge with owner being responsible for shipping. Should Masterbuilt require return of component(s) in question for inspection Masterbuilt will be responsible for shipping charges to return requested item. This warranty excludes property damage sustained due to misuse, abuse, accident, damage arising out of transportation, or damage incurred by commercial use of this product.

This expressed warranty is the sole warranty given by Masterbuilt and is in lieu of all other warranties, expressed or implied including implied warranty, merchantability, or fitness for a particular purpose. Neither Masterbuilt nor the retail establishment selling this product, has authority to make any warranties or to promise remedies in addition to or inconsistent with those stated above.

Masterbuilt's maximum liability, in any event, shall not exceed the purchase price of the product paid by the original consumer/ purchaser. Some states do not allow the exclusion or limitation of incidental or consequential damages. In such a case, the above limitations or exclusions may not be applicable.

California residents only: Notwithstanding this limitation of warranty, the following specific restrictions apply; if service, repair, or replacement of the product is not commercially practical, the retailer selling the product or Masterbuilt will refund the purchase price paid for the product, less the amount directly attributable to use by the original buyer prior to the discovery of the nonconformity. Owner may take the product to the retail establishment selling this product in order to obtain performance under warranty. This expressed warranty gives you specific legal rights, and you may also have other rights which vary from state to state.

Go Online www.masterbuilt.com
 or complete and return to
 Attn: Warranty Registration
 Masterbuilt Mfg. Inc.
 1 Masterbuilt Court - Columbus, GA 31907

Name: _____ Address : _____ City: _____

State/Province: _____ Postal Code: _____ Phone Number: (____) - _____

E-mail Address: _____

Model Number: _____ Serial Number: _____

Purchase Date: ____ - ____ - ____ Place of Purchase: _____

TROUBLESHOOTING GUIDE

SYMPTOM	CAUSE	POSSIBLE SOLUTION
Power light wont come	Not plugged into wall	Check wall connection
	House fuse or Ground Fault Circuit Interrupter (GFCI) tripped	Make sure other appliances are not operating on the same electrical circuit. Check household fuses or reset (GFCI)
	Unit malfunctioning	Contact Masterbuilt at 1.800.489.1581
Unit takes excessive amount of time to heat up (longer than 60-70 min)	Unit plugged into an extension cord	Set unit so an extension cord does not have to be used
	Lid not closed properly	Close door securely
	Unit malfunctioning	Contact Masterbuilt at 1.800.489.1581
Smoker docking tube not secured	Mount hook nut not tightened	Tighten nut.
	Mount hook threads stripped	Contact Masterbuilt at 1.800.489.1581
No smoke	No wood chips	Add wood chips
	Unit plugged into an extension cord	Set unit so an extension cord does not have to be used
	Unit malfunctioning	Contact Masterbuilt at 1.800.489.1581
Chip tube not resting properly into grooves in unit	Wood chip screen not set properly, contacting unit element.	Check for wedged wood chips. Reset wood chip screen properly on chip tube
Power light is on, unit isn't heating	Element malfunctioning	Contact Masterbuilt at 1.800.489.1581

WOOD SMOKING GUIDE FOR MEATS

WOOD FLAVOR	POULTRY	FISH	HAM	BEEF	PORK	LAMB
Hickory Pungent, smoky, bacon-like flavor	✓	✓	✓	✓	✓	
Mesquite Sweet and delicate flavor	✓			✓	✓	✓
Alder Delicate, wood smoke flavor	✓	✓			✓	
Pecan Bold and hearty flavor	✓	✓			✓	
Maple Sweet, subtle flavor	✓	✓			✓	
Apple Sweet, delicate flavor	✓					
Cherry Sweet, delicate flavor	✓				✓	



GENERAL WARNINGS AND SAFETY INFORMATION



- **Avoid bumping or impacting cold smoker when in use.**
- **Never move when attached to smoker or when smoker is in use. Allow cold smoker to cool completely before moving or storing.**
- **To disconnect, turn switch to “OFF” position then remove plug from outlet.**
- **Unplug from outlet when not in use and before cleaning. Allow unit to cool completely before adding/removing wood chip tube.**
- **Dispose of cold ashes by placing them in aluminum foil, soaking with water and discarding in a non-combustible container.**
- **Do not store cold smoker with HOT ashes inside unit. Store only when all surfaces are cold.**
- **Accessory attachments not supplied by Masterbuilt Manufacturing, Inc. are not recommended and may cause injury.**
- **The use of accessory attachments not recommended by the appliance manufacturer may cause injuries.**
- **Never use cold smoker for anything other than its intended purpose. This unit is not for commercial use.**
- **Always use cold smoker in accordance with all applicable local, state and federal fire codes.**
- **Longer extension cords are available and may be used if care is exercised in their use.**
- **If a longer extension cord is used, the marked rating should be at least as great as the electrical rating of the appliance.**
- **The extension cord must be a grounding -type 3-wire cord.**
- **Outdoor extension cords must be used with outdoor use products and are marked with suffix “W” and with the statement “Suitable for Use with Outdoor Appliances.**
- **CAUTION - To reduce the risk of electric shock, keep extension cord connection dry and off the ground.**
- **Do not clean this product with a water spray or the like.**
- **Longer detachable power-supply cord or extension cords are available and may be used if care is exercised in their use. If a longer detachable power-supply cord or extension cord is used:**
 - 1. The marked electrical rating of the cord set or extension cord should be at least as great as the electrical rating of the appliance; and**
 - 2. The cord should be arranged so that it will not drape over the counter top or tabletop where it can be pulled by children or tripped over intentionally.**
- **Store product indoor when not in use – out of the reach of children.**

SAVE THESE INSTRUCTIONS

LET'S GET STARTED!

- The cold smoker is a smoke generating accessory and is intended for use with Masterbuilt™ Smokers.
- This is a smoke generator. Allow sufficient time for smoking.
- This unit is for OUTDOOR USE ONLY.
- “Pre-season” the smoker that the cold smoker is attached to prior to first use. See page 11.
- Store cold smoker in a dry area after use.
- Extreme cold temperatures may extend cooking times when used with a smoker for cooking purposes and not as a cold smoker.
- CLEAN AFTER EVERY USE. This will extend the life of the unit and prevent mold and mildew.

IMPORTANT FACTS ABOUT USING COLD SMOKER

- Do NOT move unit when attached to smoker.
- Wood chip tube MUST be in place when cold smoker is in use.
- Wood chips must be used in order to produce smoke and create the smoke flavor. See “Wood Smoking Guide for Meats” section in this manual.
- Do not open cold smoker door unless necessary. Opening chip tube cap causes smoke to escape and may cause wood to flare up. Closing the cap will re-stabilize the temperature and stop flare up.
- Do not leave old wood ashes in the chip tube screen or ash tray. Once ashes are cold, empty ash tray. Tray should be cleaned out prior to and after each use to prevent ash buildup.
- This is a smoker accessory. There will be a lot of smoke produced when using wood chips. Smoke will escape through seams and turn the inside of unit black. This is normal. To minimize smoke loss around smoker loading port and mount tube, adjust nut on mount hook to further tighten seal against body.
- Opening unit during smoking process may extend smoking time due to heat loss.
- When used with a smoker for cooking purposes, outside temperatures cooler than 65°F (18°C) and/or altitudes above 3,500 feet (1067m), may require additional cooking time. To ensure that meat is completely cooked use a meat thermometer to test internal temperature.

CAUTION

When lid is opened and chip tube cap is removed, a flare up may occur. Never remove chip cap during use. Wait for wood chips to burn down before adding more chips. Do not spray with water.

WARNING

COMBUSTION BY-PRODUCT PRODUCED WHEN USING THIS PRODUCT CONTAINS CHEMICALS KNOWN TO THE STATE OF CALIFORNIA TO CAUSE BIRTH DEFECTS, OTHER REPRODUCTIVE HARM, OR CANCER.

THE MATERIALS USED IN THIS PRODUCT MAY CONTAIN LEAD, A CHEMICAL KNOWN TO THE STATE OF CALIFORNIA TO CAUSE BIRTH DEFECTS AND OTHER REPRODUCTIVE HARM.

COLD SMOKER DOES NOT COOK FOOD. A SECONDARY PROCESS IS NEEDED TO COOK FOOD BEFORE CONSUMING

NOT RECOMMENDED FOR USE DURING EXTREMELY HOT WEATHER CONDITIONS AS A SLOW SMOKER. UNCOOKED FOOD MAY SPOIL IF LEFT OUT IN INCLEMENTLY HOT WEATHER.

HOW TO USE CHIP TUBE

- Never use wood chunks.
- Use dry, un-soaked wood chips.
- Before starting unit, place wood chips in chip tube.
- Wood chips should be below or level with top rim of chip tube.
- Always place chip tube cap on chip tube before smoking.

PRE-SEASON INSTRUCTIONS

Preseason smoker prior to first use with cold smoker. Run unit for 1 hour with half load of wood chips. Shut down and allow to cool. Smoke will appear during this time, this is normal.

HOW TO CLEAN COLD SMOKER

ALWAYS MAKE SURE UNIT IS UNPLUGGED AND COOL TO THE TOUCH BEFORE CLEANING AND STORING.

Fig. A

Remove ashes from ash tray (6) once unit and wood chip embers have cooled.

Remove ash build up, residue and dust with a damp cloth from ash tray (6) and inside cold smoker body (10).

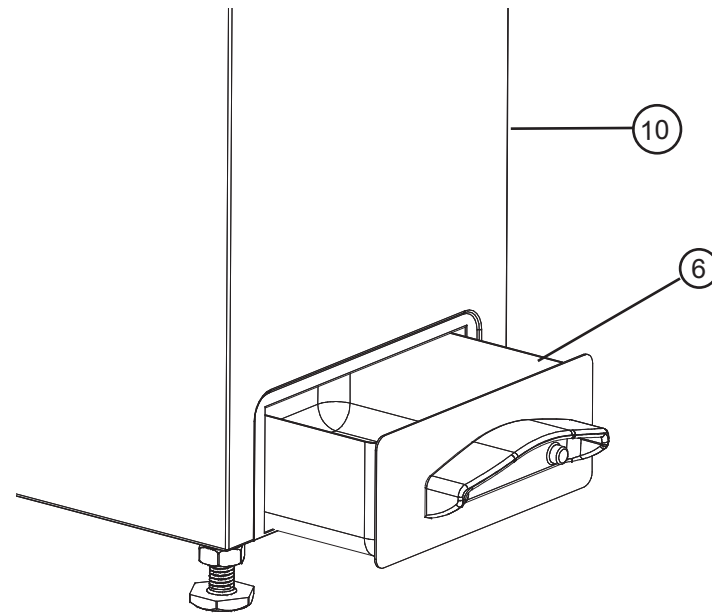
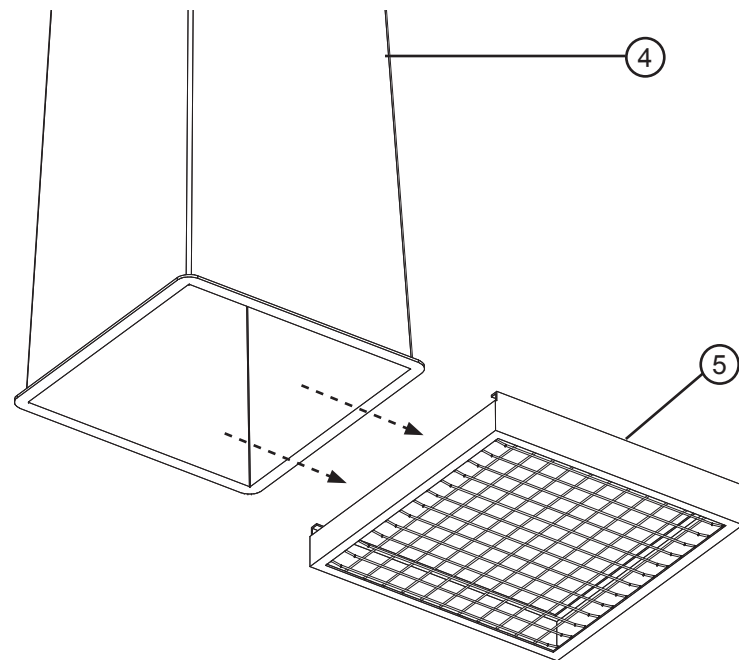

Fig. B

Slide chip tube screen (5) from base of chip tube (4) as shown.

Clean also with a damp cloth.



DO NOT RETURN TO RETAILER

For Assembly Assistance, Missing or Damaged Parts
Call: MASTERBUILT Customer Service at 1-800-489-1581.

PARTS LIST

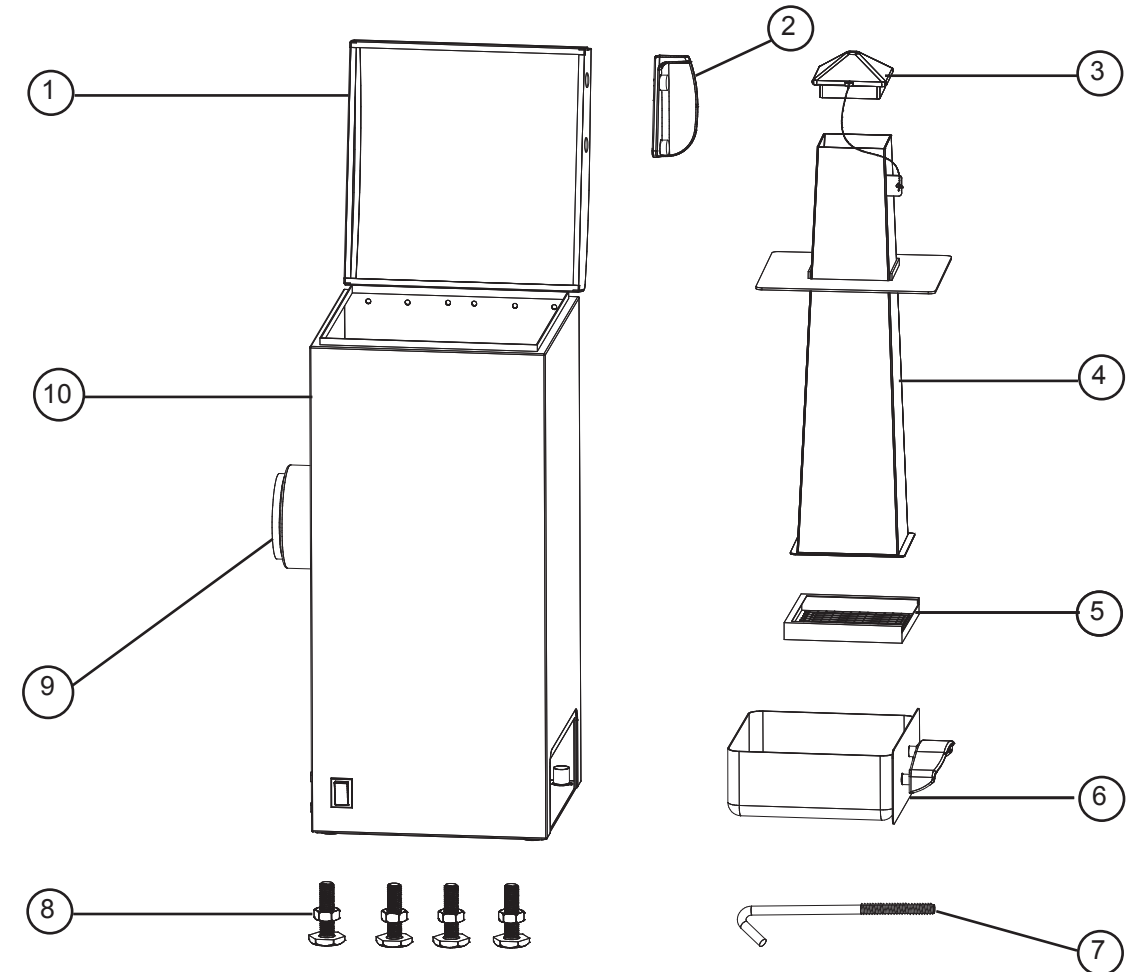

PART #	QUANTITY	DESCRIPTION
1	1	Cold Smoker Lid
2	1	Lid Handle
3	1	Chip Tube Cap
4	1	Chip Tube Body
5	1	Chip Tube Screen
6	1	Ash Tray
7	1	Mount Hook
8	4	Stabilizing Legs
9	1	Mount Tube
10	1	Cold Smoker Body

Model 20070112	
REPLACEMENT PART	ITEM NO
Lid Handle Kit	9907100025
Lid Stop Kit	9907110001
Chip Tube Cap Kit	9907100024
Ash Tray Kit	9907110 002
Smoker Mount Hook Kit	9907110003
Chip Tube Screen	9007110013
Chip Tube Body	9007110014
Cap Chain	9007110005
Foot	910050006
Instruction Manual	9807100051

HARDWARE

A
Qty: 2
Phillips Head Screw

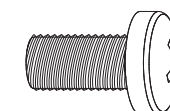

B
Qty: 1
Wing Nut



ASSEMBLY

- BEFORE ASSEMBLY READ ALL INSTRUCTIONS CAREFULLY.
- ASSEMBLE UNIT ON A CLEAN, FLAT SURFACE.

STEP 1

Align lid handle (2) with holes on the side of cold smoker lid (1) and secure with phillips head screw (A).

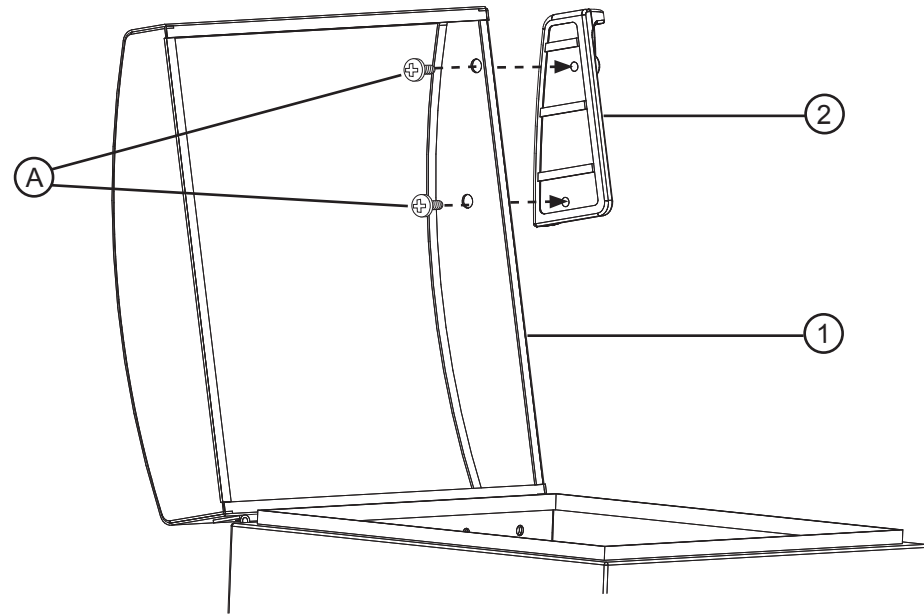

STEP 2

Screw adjust stabilizing legs (8) into base of cold smoker body (10). Do not fully tighten as they will need to be adjusted in the next step.

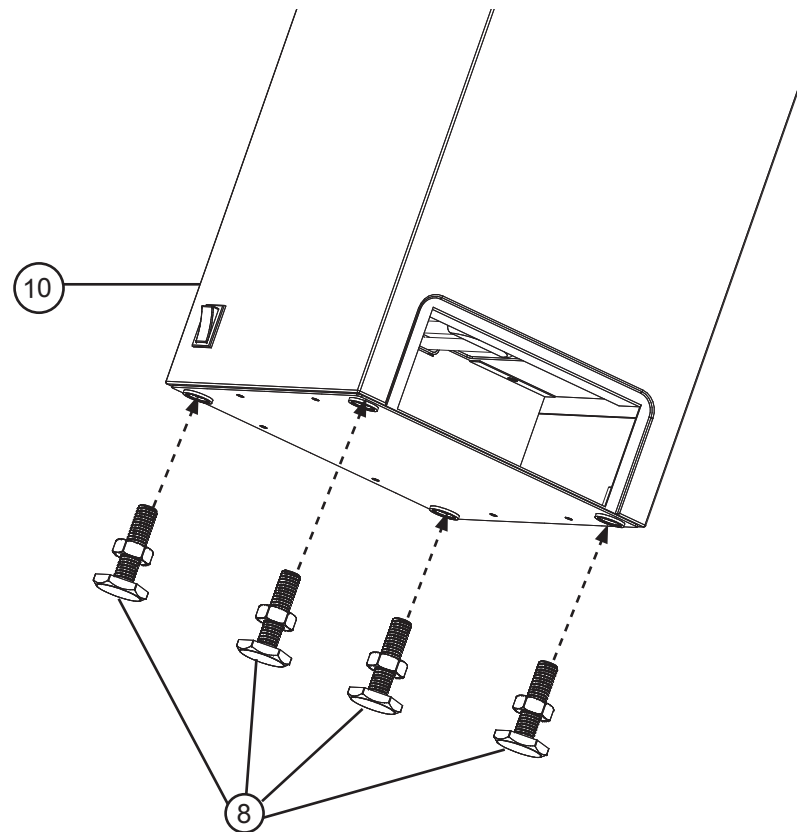

ASSEMBLY



UNIT IS NOW READY FOR USE.



For tantalizing recipes and cooking tips visit us online at:
www.dadgumthatsgood.com

ASSEMBLY

STEP 9

Place wood chip tube (4) inside cold smoker body (10), nesting onto inside ledge of the cold smoker body (10).

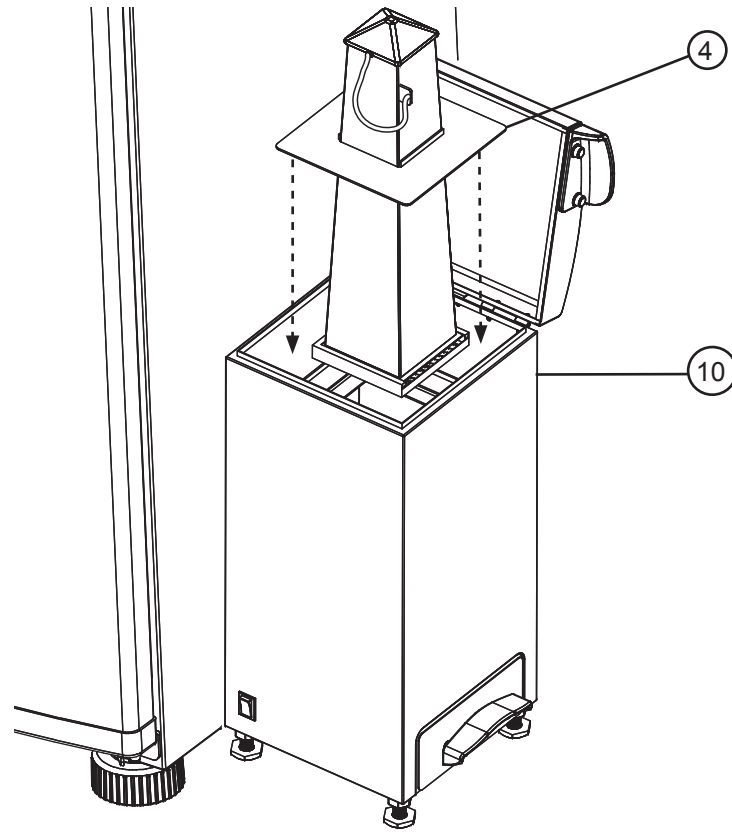

ASSEMBLY

STEP 3

Insert ash tray (6) into cold smoker body (10) as illustrated.

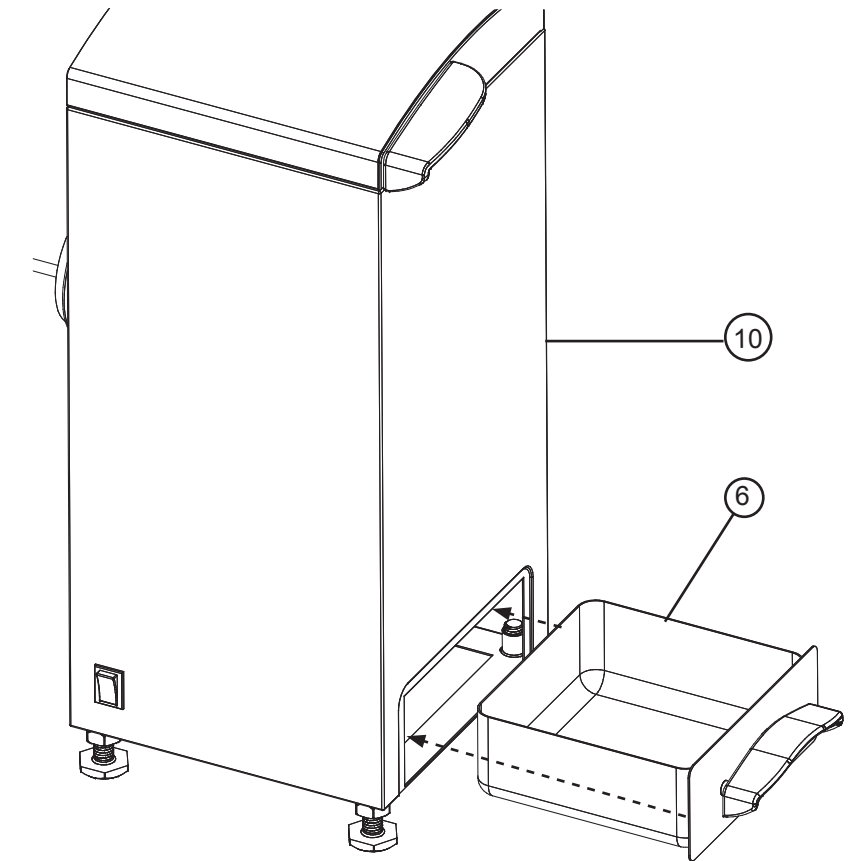

STEP 10

Once chip tube (4) is properly installed remove chip tube cap (3) and fill with wood chips.

Reset chip tube cap (3) over chip tube (4). Close cold smoker lid (1) before turning power on.

See page 12 preseason instructions then follow details below.

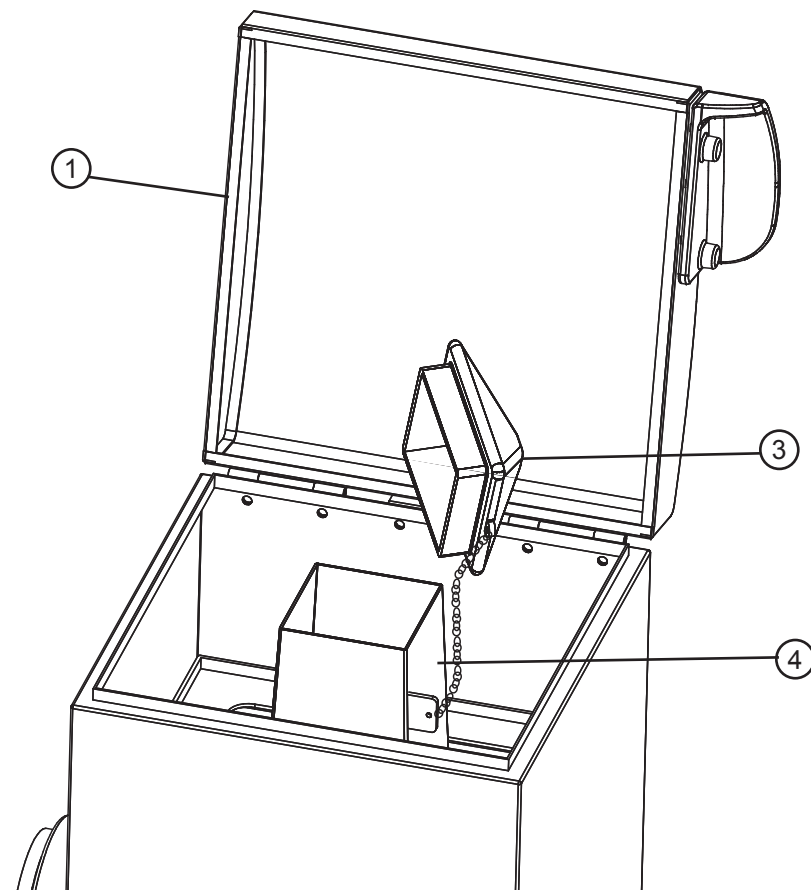

STEP 4

Insert mount hook (7) through hole of bracket in mount tube (9).

Thread wing nut (B) onto mount hook (7) as shown.

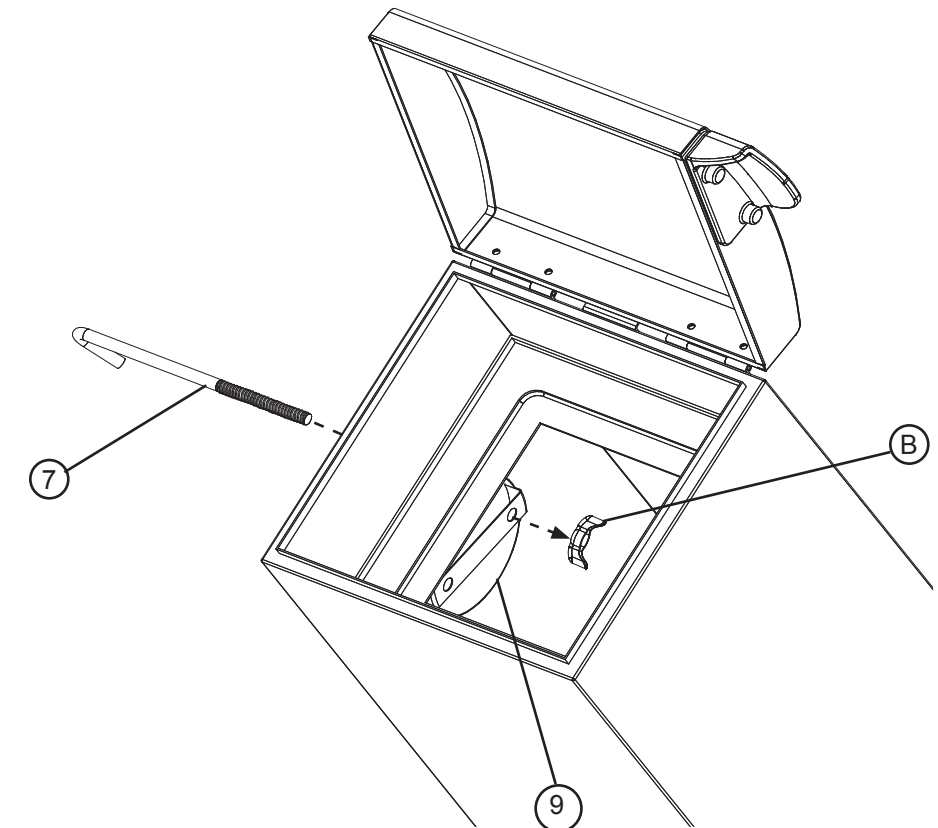

(*Some parts not shown for clarity.)

STEP 5

Align cold smoker mount tube (9) to wood chip loading port of smoker.

Insert mount tube (9) and mount hook (7) into smoker wood chip port.

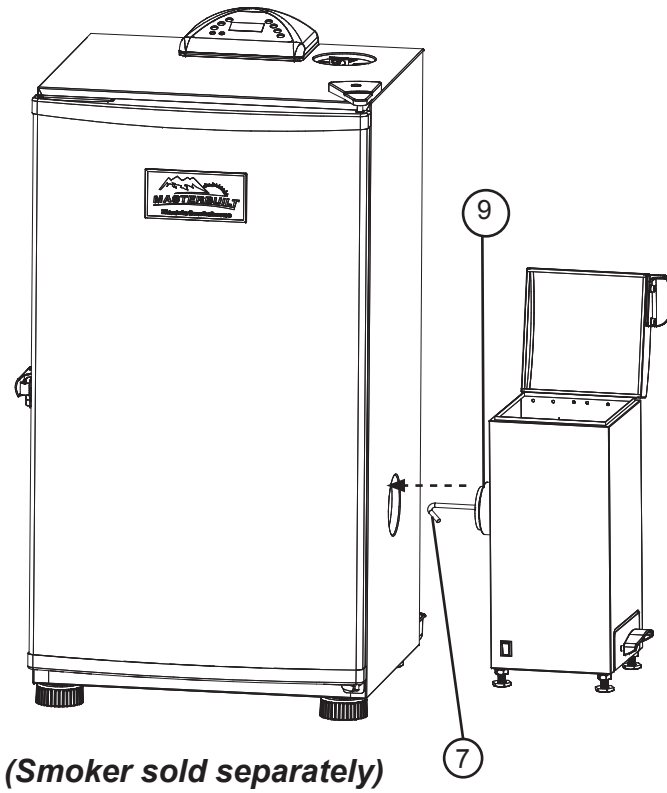

(Smoker sold separately)

STEP 6

Place mound hook (7) on the inside lip of smoker unit.

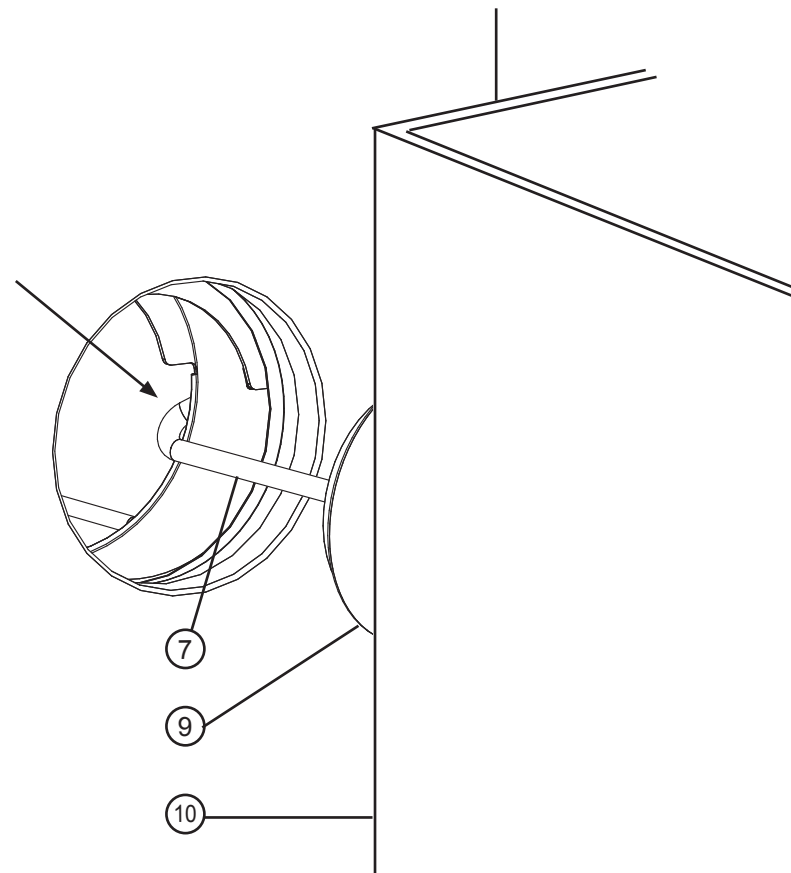

STEP 7

Tighten wing nut (B) on mount hook (7) until mount tube (9) is snug to smoker body.

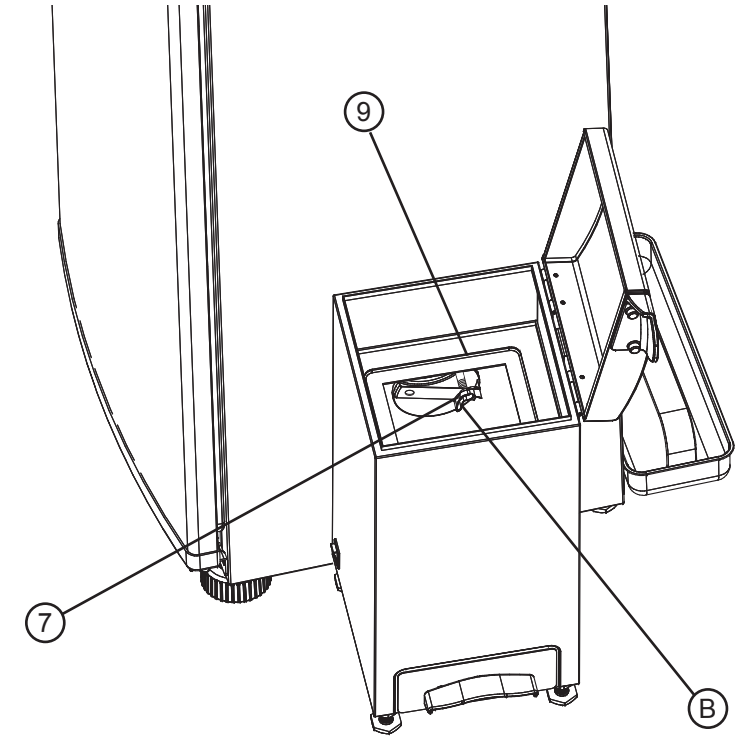

STEP 8

Before moving on to the next step, be sure that the wood chip screen (5) is in place on wood chip tube (4).

**Never use wood chip tube (4) without wood chip screen (5) in place.*

